

**PLEASE CHECK WWW.MOLEX.COM FOR LATEST PART INFORMATION**

**Part Number:** [0359780340](#)  
**Status:** **Planned for Obsolescence**  
**Description:** 3.96mm (.156") Pitch Wire-to-Board Header, Right Angle, Low Profile, 3 Circuits, Natural, Polyester Alloy

**Documents:**

[Drawing \(PDF\)](#) [RoHS Certificate of Compliance \(PDF\)](#)  
[Product Specification PS-35978-001 \(PDF\)](#)

**Agency Certification**

CSA	LR19980
TUV	R72090224
UL	E29179

**General**

Product Family	PCB Headers
Series	<a href="#">35978</a>
Application	Wire-to-Board
Product Name	MV-396™

**Physical**

Breakaway	No
Circuits (Loaded)	3
Circuits (maximum)	3
Color - Resin	Natural
Durability (mating cycles max)	30
First Mate / Last Break	No
Flammability	94V-0
Glow-Wire Compliant	Yes
Guide to Mating Part	No
Keying to Mating Part	None
Lock to Mating Part	Yes
Material - Metal	Brass
Material - Plating Mating	Tin
Material - Plating Termination	Tin
Material - Resin	Polyester Alloy
Number of Rows	1
Orientation	Right Angle
PC Tail Length (in)	0.146 In
PC Tail Length (mm)	3.70 mm
PCB Locator	No
PCB Retention	None
PCB Thickness Recommended (in)	0.062 In
PCB Thickness Recommended (mm)	1.60 mm
Packaging Type	Bag
Pitch - Mating Interface (in)	0.156 In
Pitch - Mating Interface (mm)	3.96 mm
Pitch - Term. Interface (in)	0.156 In
Pitch - Term. Interface (mm)	3.96 mm
Polarized to Mating Part	No
Polarized to PCB	No
Shrouded	No
Stackable	Yes
Surface Mount Compatible (SMC)	No
Temperature Range - Operating	-25°C to +85°C
Termination Interface: Style	Through Hole

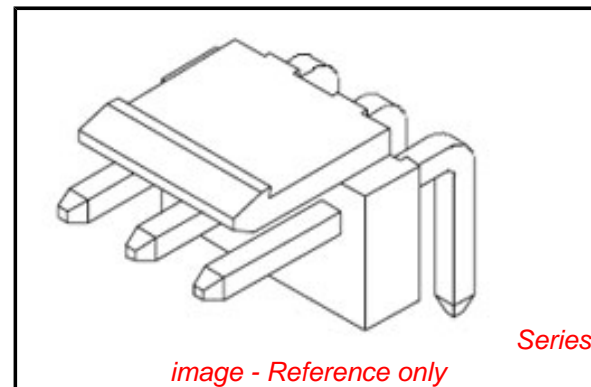

**EU RoHS**

**ELV and RoHS Compliant**  
**REACH SVHC**  
 Not Reviewed  
**Halogen-Free Status**  
 Not Reviewed

**China RoHS**



**Need more information on product environmental compliance?**

Email [productcompliance@molex.com](mailto:productcompliance@molex.com)  
 For a multiple part number RoHS Certificate of Compliance, [click here](#)

Please visit the [Contact Us](#) section for any non-product compliance questions.

**Search Parts in this Series**

[35978Series](#)

**Mates With**

[35977 Wire-to-Board Housing](#)

**Electrical**

Current - Maximum per Contact

7A

Voltage - Maximum

250V

**Material Info****Reference - Drawing Numbers**

Product Specification

PS-35978-001

Sales Drawing

SD-35978-002

This document was generated on 06/07/2010

**PLEASE CHECK [WWW.MOLEX.COM](http://WWW.MOLEX.COM) FOR LATEST PART INFORMATION**

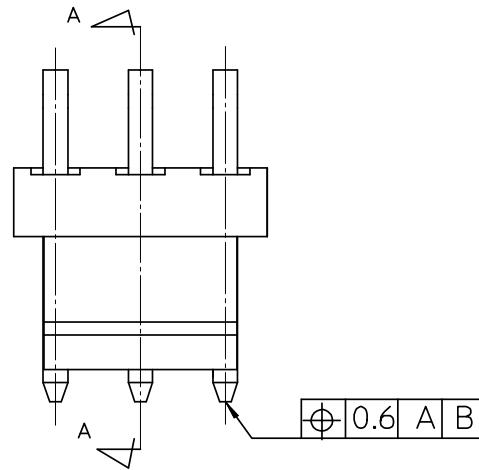
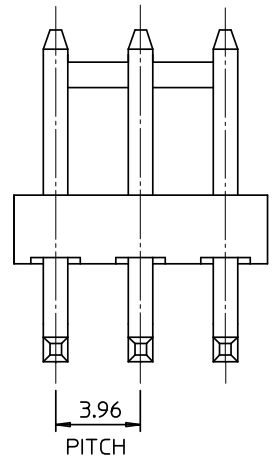

NOTES

- MATERIAL : HEADER - PA66, PBT/PC  
PIN : BRASS(CDA 2700)
- FINISHES : PIN  
THICKNESS - TIN 3.0 MICROMETER MIN.  
OVER Cu 1.5 MICROMETER MIN.
- PRODUCT SPECIFICATION : PS-35978-002

LEGEND

- 35978-\*\*\*\*
- COLOR : 0 - WHITE  
1 - BLACK  
2 - RED  
3 - YELLOW  
4 - BLUE
  - MATERIAL : 2 : PA66 4 : PBT/PC
  - CURCUIT NO. (02,03,04...)

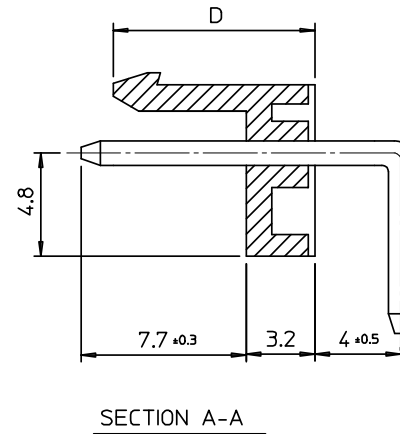
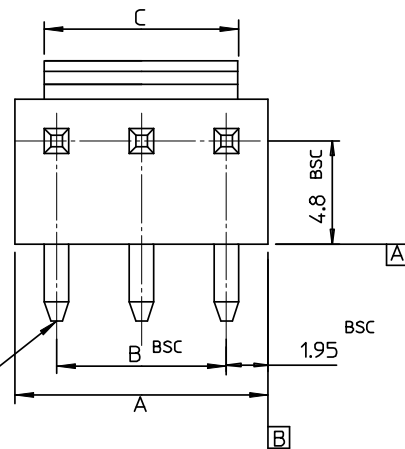
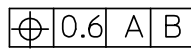
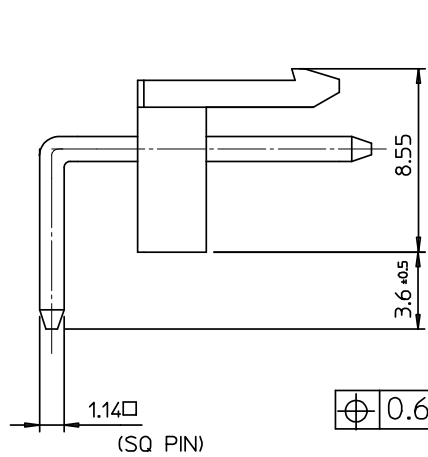

9.4	56.50	55.44	59.40	3597815**	35978-15**	15		
	52.54	51.48	55.44	3597814**	-14**	14		
9.7	48.58	47.52	51.48	3597813**	-13**	13		
	44.62	43.56	47.52	3597812**	-12**	12		
	40.66	39.60	43.56	3597811**	-11**	11		
	36.70	35.64	39.60	3597810**	-10**	10		
	32.74	31.68	35.64	3597809**	-09**	9		
	28.78	27.72	31.68	3597808**	-08**	8		
	24.84	23.76	27.72	3597807**	-07**	7		
	20.86	19.80	23.76	3597806**	-06**	6		
	16.90	15.84	19.80	3597805**	-05**	5		
	12.94	11.88	15.84	3597804**	-04**	4		
8.98	7.92	11.88	3597803**	-03**	3			
D	9.7	5.02	3.96	7.92	3597802**	-02**	2	
		D	C	B	A	MAT'L NO	ENG NO.	CURCUITS

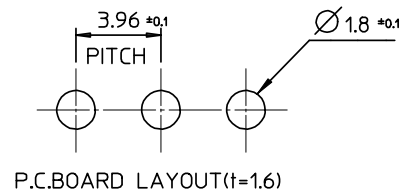

REVISED	EC NO: KOR2008-0143	2008/02/26
DRWN: JHPARK01	2008/07/16	
CHKD: WY. YANG	2008/07/16	
APPR: YUNS.IKK.IM	2008/02/27	
REV	DESCRIPTION	

QUALITY SYMBOLS	▽=0
	∇=0

GENERAL TOLERANCES (UNLESS SPECIFIED)	mm	INCH
4 PLACES	± ---	± ---
3 PLACES	± ---	± ---
2 PLACES	± ---	± ---
1 PLACE	± 0.2	± ---
ANGULAR	± 2 °	
DRAFT WHERE APPLICABLE MUST REMAIN WITHIN DIMENSIONS		

DIMENSION STYLE		SCALE	DESIGN UNITS	THIRD ANGLE PROJECTION
MM ONLY		4:1	METRIC	
DRAWN BY	DATE	TITLE		
Y. R. WI	1999/05/07	3.96 W/B HEADER ASSY(RA)		
CHECKED BY	DATE			
J. K. OH	1999/05/07			
APPROVED BY	DATE			
C. W. LEE	1999/05/07			
MATERIAL NO.	DOCUMENT NO.	SHEET NO.		
SEE TABLE	SD-35978-002	1 OF 01		

MOLEX INCORPORATED

THIS DRAWING CONTAINS INFORMATION THAT IS PROPRIETARY TO MOLEX INCORPORATED AND SHOULD NOT BE USED WITHOUT WRITTEN PERMISSION