

# 5.00mm (0.196") PITCH CONNECTOR



Wire-to-Board  
Wafer

YPAW500 Series

DIP

Right Angle

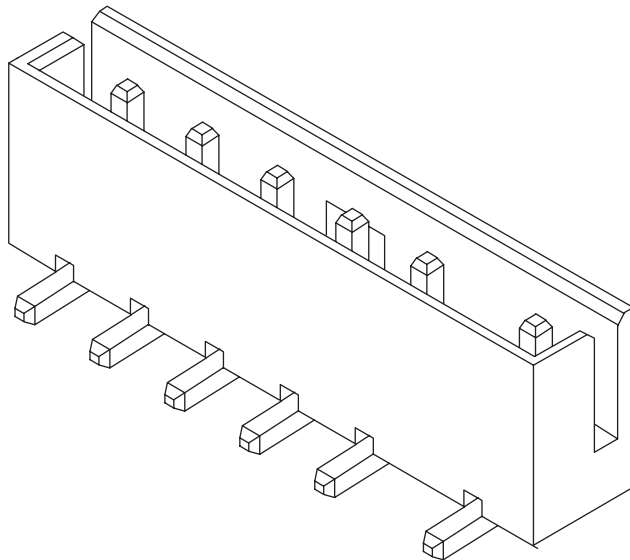

## Material

I/NO	DESCRIPTION	TITLE	MATERIAL
1	WAFER	YPAW500	PA66, UL94 V Grade
2	PIN		Brass & Tin-Plated

## Available Pin

PARTS NO.	DIM. A	DIM. B	DIM. C
YPAW500-02P	15.3	13.3	7.5
YPAW500-03P	20.3	18.3	12.5
YPAW500-04P	25.3	23.3	17.5
YPAW500-05P	30.2	28.3	22.5
YPAW500-06P	35.3	33.3	27.5

## Specification

ITEM	SPEC
Voltage Rating	AC/DC 250V
Current Rating	AC/DC 5A
Operating Temperature	-25°C ~ +85°C
Contact Resistance	30mΩ MAX
Withstanding Voltage	AC1500V/1min
Insulation Resistance	1000MΩ MIN
Applicable Wire	-
Applicable P.C.B	1.2~1.6mm
Applicable FPC/FFC	-
Solder Height	-
Crimp Tensile Strength	-
UL FILE NO	E108706

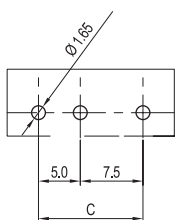
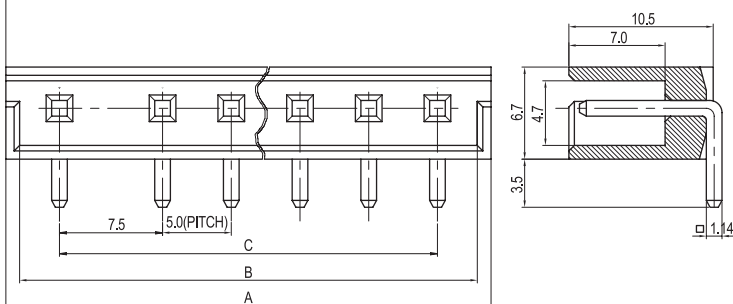
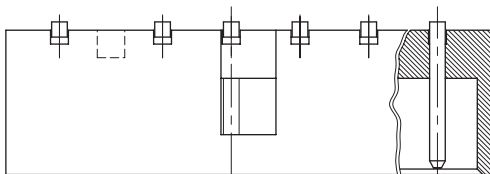

PCB LAYOUT

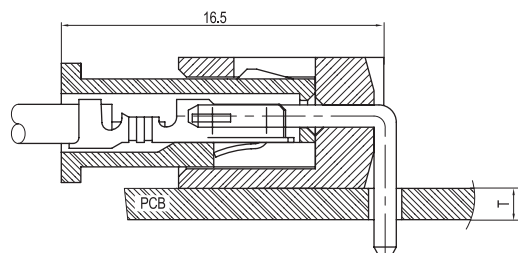

PCB ASS'Y