

Quad Segment Photo Sensor IC

ISL58344

The ISL58344 photo sensor IC has a wide optical spectral sensitivity from 400nm to 1000nm. It is good for multiple light source applications, such as laser base projectors. The three sets of gain registers can be used to adjust optical-to-electrical conversion gain for each RED (R), GREEN (G), and BLUE (B) laser or any wavelength in the spectral range for the application. The ISL58344 is a single die device that has four identical photo detectors arranged in segments that are optimized for laser beam spot alignment. Quad segments can be used as a single photo diode for optical power calibration and gamma correction. The detectors can also be split into two sections with subtraction signal output for laser beam position alignment. Beam detection can also be used to compensate for MEMS scanning projector geometric distortions and temperature distortions. Registers can be updated in real time while device is in operation.

The ISL58344 can be put in sleep mode through serial interface, where it consumes virtually no power. The ENA pin, when low, will put the device in standby mode. Toggling the ENA pin Hi will turn the device on quickly.

The ISL58344 operates from a single +3.3V supply. It is available in a space-saving 9 pin glass top BGA package.

Related Literature

- See TB478 “PCB Assembly Guidelines for Shell-Op 3D Package”

Get Full Datasheet

Features

- Sensitive from 400nm to 1000nm with Patented Technology for Improved Blue Photo Response
- Differential Voltage Output
- Internal Output Reference or External Output Reference
- Single +3.3V Power Supply
- Serial Interface for Gain Calibration
- Fast Settling Time <20ns
- Wide Signal Bandwidth >50MHz
- Wide Signal Gain Dynamic Range >25dB
- Sleep Mode for Conserving Power
- Quad PD Segments Provide Laser Beam Offset for Beam Realignment Capability
- White Balance for LCoS and MEMS Systems
- Small 9-ball Optical Chip Scale Package (OCSP) (2.2mmx2.2mm)
- Glass Top Package Compatible with Near UV and Blue LDs
- Intersil 3-wire SPI Interface

Applications

- Optical Power Monitoring
- Laser Based/LED Based Pico-Projectors
- Laser Based/LED Based projection TV

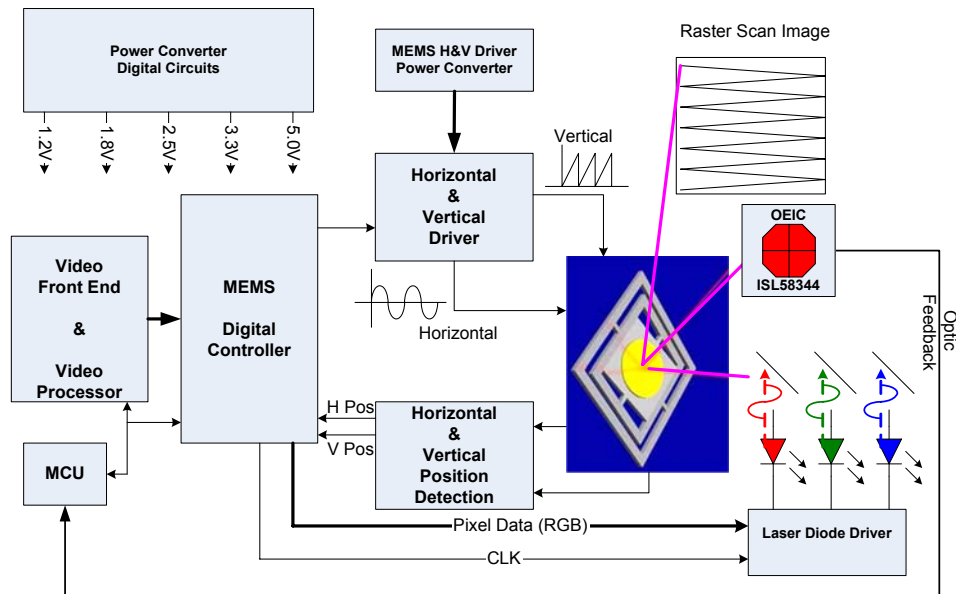

FIGURE 1. APPLICATION BLOCK DIAGRAM

For additional products, see www.intersil.com/product_tree

Intersil products are manufactured, assembled and tested utilizing ISO9000 quality systems as noted in the quality certifications found at www.intersil.com/design/quality

Intersil products are sold by description only. Intersil Corporation reserves the right to make changes in circuit design, software and/or specifications at any time without notice. Accordingly, the reader is cautioned to verify that data sheets are current before placing orders. Information furnished by Intersil is believed to be accurate and reliable. However, no responsibility is assumed by Intersil or its subsidiaries for its use; nor for any infringements of patents or other rights of third parties which may result from its use. No license is granted by implication or otherwise under any patent or patent rights of Intersil or its subsidiaries.

For information regarding Intersil Corporation and its products, see www.intersil.com