

Intelligent Power Module (RH-Series)

■ Maximum Ratings and Characteristics

• Absolute Maximum Ratings ($T_c=25^\circ\text{C}$)

Items	Symbols	Ratings		Units
		Min.	Max.	
DC Bus Voltage	V_{DC}	0	450	V
DC Bus Voltage (surge)	$V_{DC(Surge)}$	0	500	
DC Bus Voltage (short operating)	V_{SC}		400	
Collector-Emitter Voltage	V_{CES}	0	600	
Inverter	Continuous	I_C	20	A
Collector	1ms	I_{CP}	40	
Current	Duty=49.6%	$-I_C$	20	
Collector Power Dissipation <small>One Transistor</small>	P_C		63	W
Voltage of Power Supply for Driver	V_{CC}	-0.3	20	V
Input Signal Voltage	V_{IN}	0	V_Z	V
Input Signal Current	I_{IN}		1	mA
Alarm Signal Voltage	V_{ALM}	0	V_{CC}	V
Alarm Signal Current	I_{ALM}		15	mA
Junction Temperature	T_J		150	°C
Operating Temperature	T_{OP}	-20	100	
Storage Temperature	T_{stg}	-40	125	
Isolation Voltage	A.C. 1min.	V_{iso}	2500	V
Screw Torque	Mounting (M4)		2.0	Nm

■ Outline Drawing

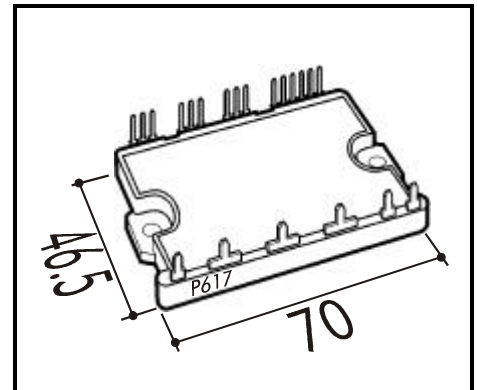

• Electrical Characteristics of Power Circuit (at $T_J=25^\circ\text{C}$, $V_{CC}=15\text{V}$)

Items	Symbols	Conditions	Min.	Typ.	Max.	Units
Collector Current At Off Signal Input	I_{CES}	$V_{CE}=600\text{V}$, Input Terminal Open			1.0	mA
Collector-Emitter Saturation Voltage	$V_{CE(Sat)}$	$I_C=20\text{A}$			2.7	V
Forward Voltage of FWD	V_F	$-I_C=20\text{A}$			3.5	V

• Electrical Characteristics of Control Circuit (at $T_J=25^\circ\text{C}$, $V_{CC}=15\text{V}$)

Items	Symbols	Conditions	Min.	Typ.	Max.	Units
Current of P-Line Side Driver (One Unit)	I_{CCP}	$f_{SW}=0\sim 15\text{kHz}$, $T_C=-20\sim 100^\circ\text{C}$		2.0	5.0	mA
Current of N-Line Side Driver (Three Units)	I_{CCN}	$f_{SW}=0\sim 15\text{kHz}$, $T_C=-20\sim 100^\circ\text{C}$		4.0	10.0	
Input Signal Threshold Voltage	$V_{IN(th)}$	On	1.00	1.35	1.70	V
		Off	1.25	1.60	1.95	
Input Zener Voltage	V_Z	$R_{IN}=20\text{k}\Omega$		8.0		
IGBT Chips Over Heating Protec. Temp. Level	T_{JOH}	Surface Of IGBT Chip	150			°C
Hysteresis	T_{JH}			20		
Inverter Collector Current Protection Level	I_{OC}	N-Side, (N1-N2 open)	30	37	44	A
Over Current Detecting Time	t_{DOC}	$T_J=25^\circ\text{C}$		5.0	7.0	μs
Alarm Signal Hold Time	t_{ALM}		1.0	2.0		ms
Over Current Detecting Resistance Value	R_{OC}			5.4		$\text{m}\Omega$
Under Voltage Protection Level	V_{UV}		11.0		12.5	V
Hysteresis	V_H		0.2		0.8	

• Dynamic Characteristics (at $T_C=T_J=125^\circ\text{C}$, $V_{CC}=15\text{V}$)

Items	Symbols	Conditions	Min.	Typ.	Max.	Units
Switching Time	t_{ON}	$I_C=20\text{A}$, $V_{DC}=300\text{V}$	0.5			μs
	t_{OFF}				3.5	
	t_{RR}	$I_F=20\text{A}$, $V_{DC}=300\text{V}$			0.5	

• Thermal Characteristics

Items	Symbols	Conditions	Min.	Typ.	Max.	Units
Thermal Resistance	$R_{th(j-c)}$	Inverter IGBT			2.00	°C/W
	$R_{th(j-e)}$	Diode			3.60	
	$R_{th(c-f)}$	With Thermal Compound		0.05		

■ Equivalent Circuit

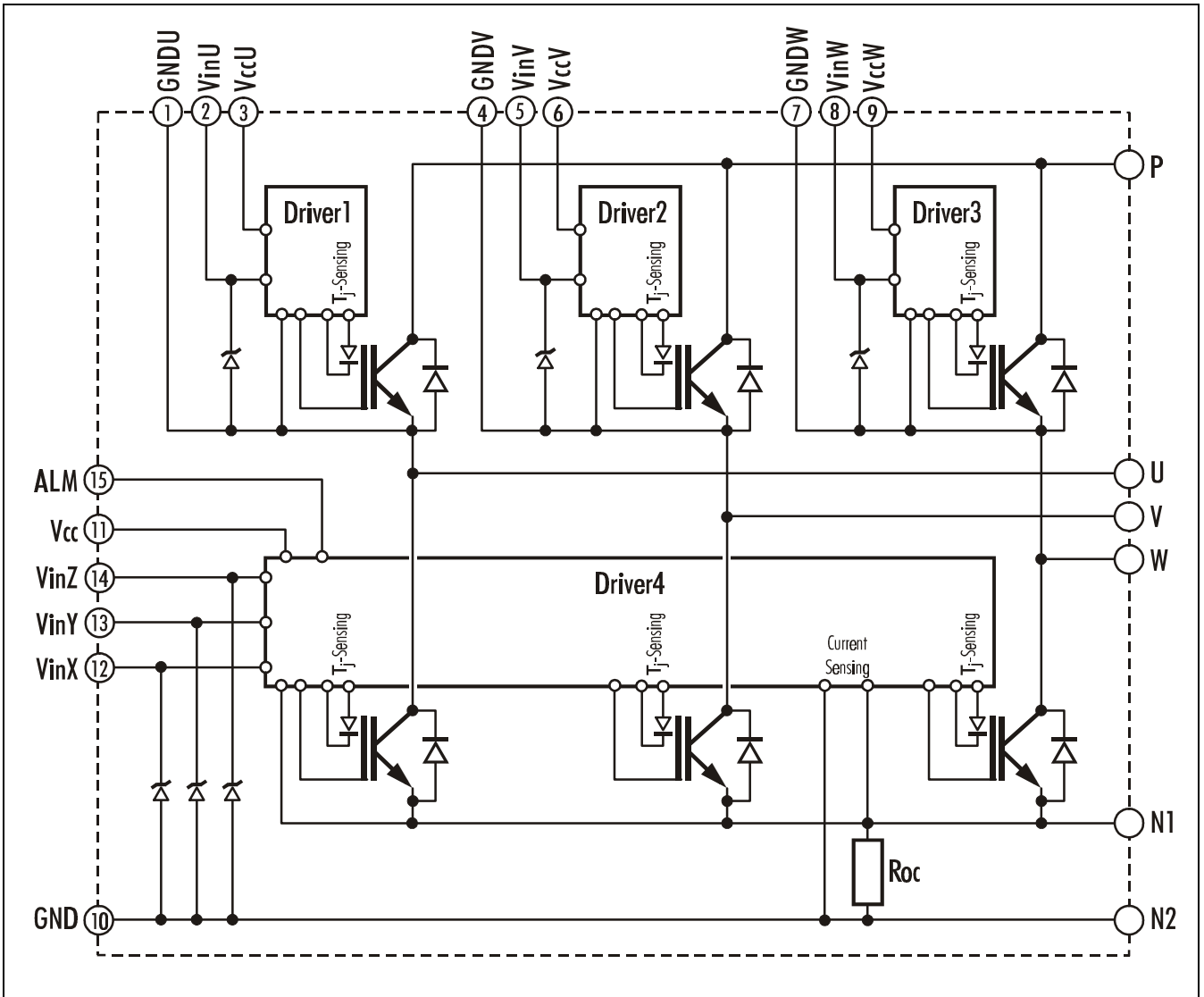

Drivers include following functions

- Over-current protection circuit
- Amplifier for driver
- Under-voltage protection circuit
- IGBT Chip overheating protection

■ Inverter

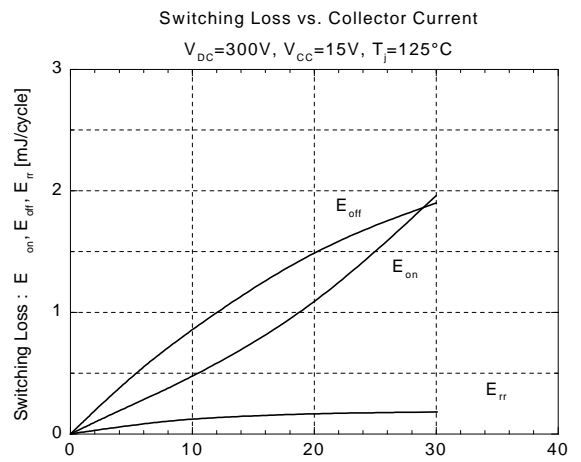
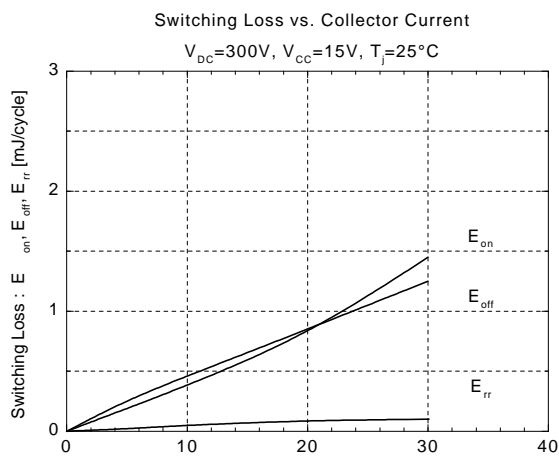
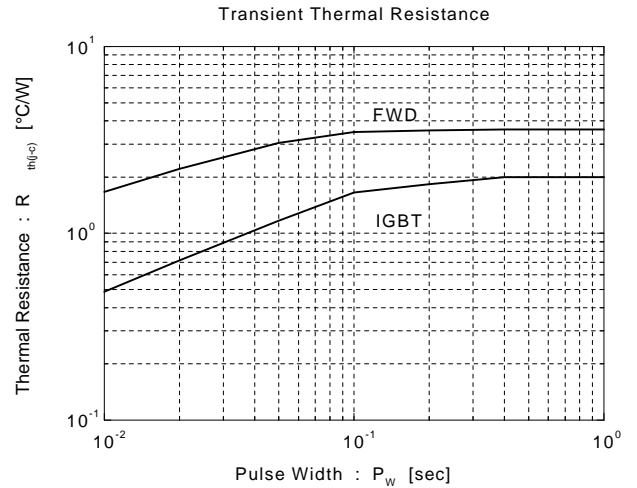
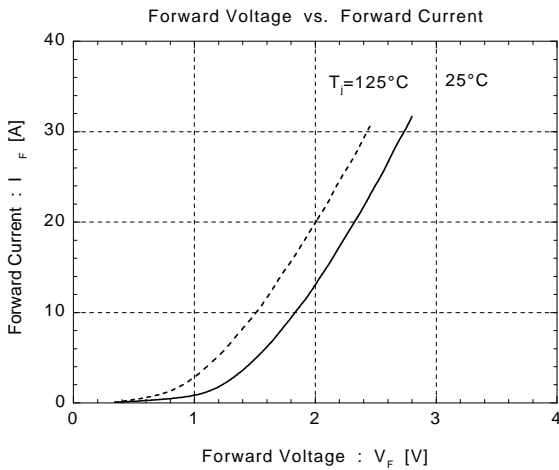
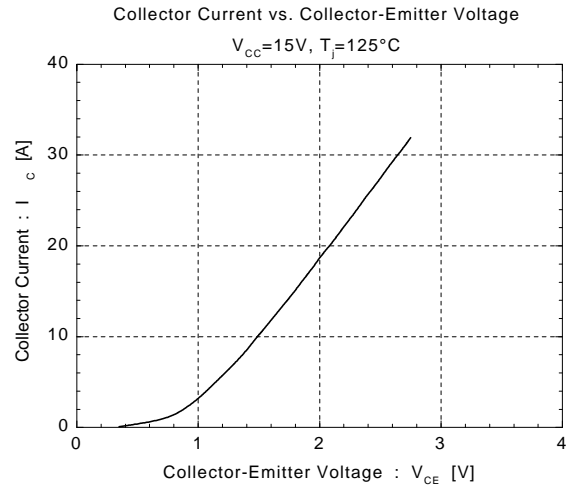
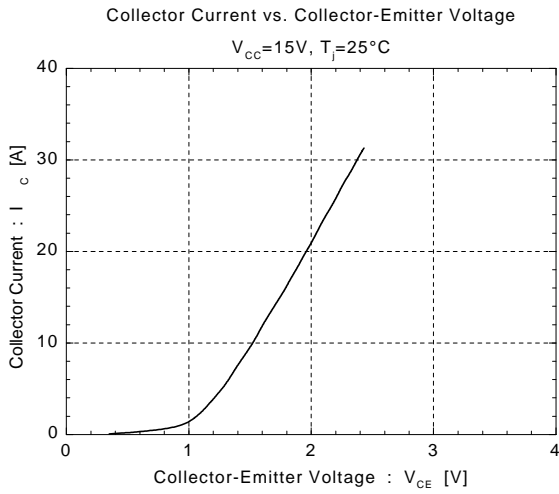

■ Outline Drawing

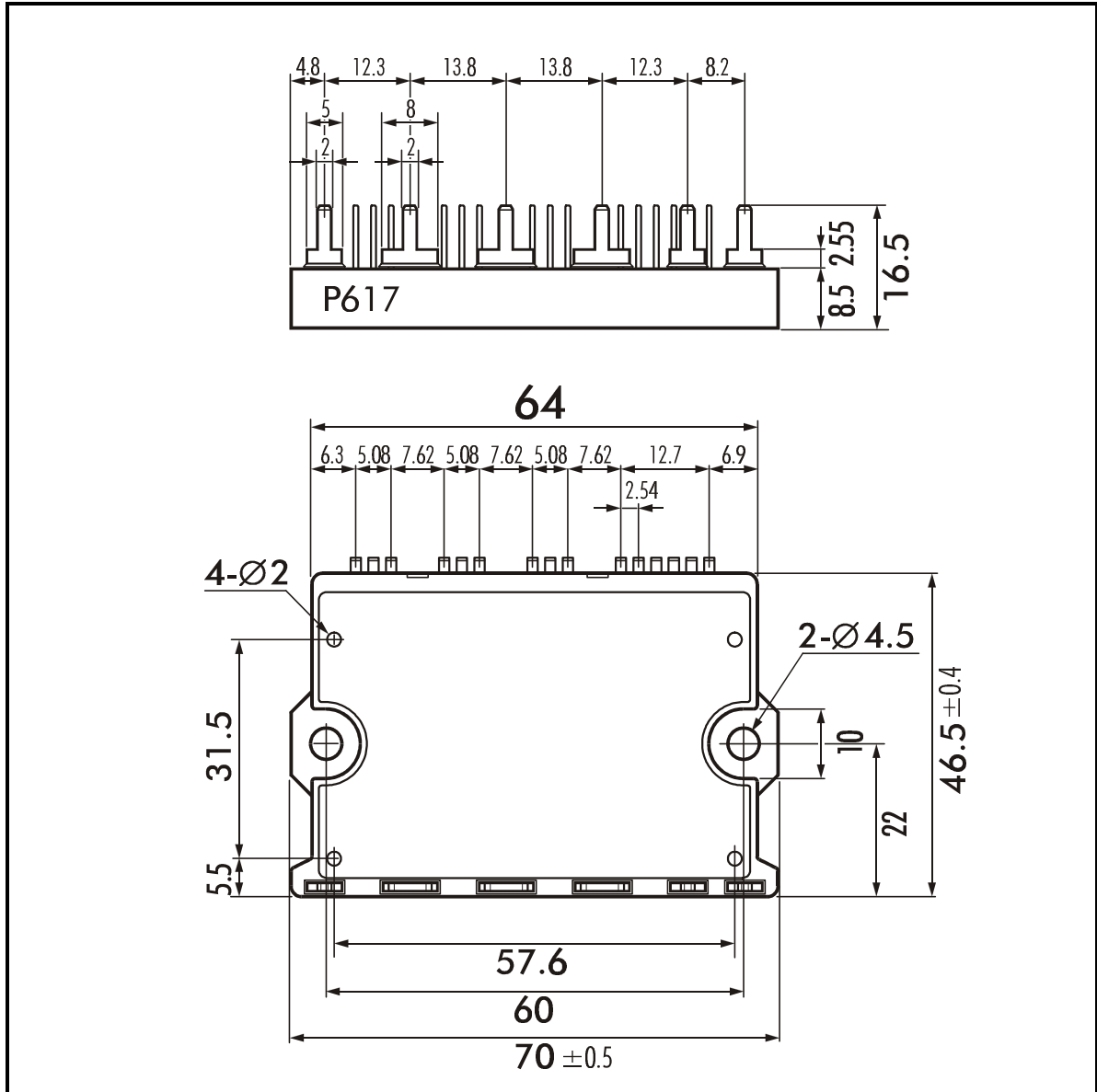

Weight: 50g