

# BCR20A, BCR20B, BCR20C, BCR20E

MEDIUM POWER USE

A, B, C : NON-INSULATED TYPE, E : INSULATED TYPE, GLASS PASSIVATION TYPE

BCR20A, BCR20B, BCR20C, BCR20E



- **IT (RMS)** ..... **20A**
- **VDRM** ..... **400V/500V**
- **IFGT I, IRGT I, IRGT III** ..... **30mA**

OUTLINE DRAWING

Dimensions  
in mm

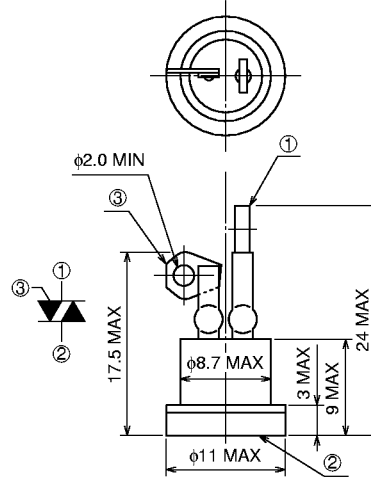

- ① T1 TERMINAL
- ② T2 TERMINAL
- ③ GATE TERMINAL

BCR20A

## APPLICATION

Contactless AC switches, light dimmer,  
on/off control of traffic signals, on/off control of copier lamps, microwave ovens,  
solid state relay

## MAXIMUM RATINGS

Symbol	Parameter	Voltage class		Unit
		8	12	
VDRM	Repetitive peak off-state voltage *1	400	500	V
VDSM	Non-repetitive peak off-state voltage *1	600	700	V

Symbol	Parameter	Conditions		Ratings	Unit
		BCR20A, B, C	BCR20E		
IT (RMS)	RMS on-state current	Commercial frequency, sine full wave, 360° conduction	Tc=98°C	20	A
ITSM	Surge on-state current	60Hz sinewave 1 full cycle, peak value, non-repetitive		220	A
I <sub>F</sub>	I <sub>F</sub> for fusing	Value corresponding to 1 cycle of half wave 60Hz, surge on-state current		203	A <sup>2</sup> s
P <sub>GM</sub>	Peak gate power dissipation			5.0	W
P <sub>G(AV)</sub>	Average gate power dissipation			0.5	W
V <sub>GM</sub>	Peak gate voltage			10	V
I <sub>GM</sub>	Peak gate current			2.0	A
T <sub>J</sub>	Junction temperature			-20 ~ +125	°C
T <sub>stg</sub>	Storage temperature			-20 ~ +125	°C

\*1. Gate open.

# BCR20A, BCR20B, BCR20C, BCR20E

MEDIUM POWER USE

A, B, C : NON-INSULATED TYPE, E : INSULATED TYPE, GLASS PASSIVATION TYPE

## MAXIMUM RATINGS (continue)

Symbol	Parameter	Conditions	Ratings	Unit
—	Weight (Typical value)	BCR20A	3.5	g
		BCR20B	9.0	
		BCR20C	9.0	
		BCR20E	11	
—	Soldering temperature	BCR20A only, 10 sec.	230	°C
—	Mounting torque	BCR20C only	30	kg·cm
			2.94	N·m
V <sub>iso</sub>	Isolated voltage	BCR20E only, T <sub>a</sub> =25°C, AC 1 minute, T <sub>2</sub> terminal to base	1500	V

## ELECTRICAL CHARACTERISTICS

Symbol	Parameter	Test conditions	Limits			Unit
			Min.	Typ.	Max.	
I <sub>DRM</sub>	Repetitive peak off-state current	T <sub>j</sub> =125°C, V <sub>DRM</sub> applied	—	—	3.0	mA
V <sub>TM</sub>	On-state voltage	T <sub>c</sub> =25°C, T <sub>b</sub> =25°C (BCR20E only), I <sub>TM</sub> =30A, Instantaneous measurement	—	—	1.5	V
V <sub>FGT I</sub>	Gate trigger voltage *2	T <sub>j</sub> =25°C, V <sub>D</sub> =6V, R <sub>L</sub> =6Ω, R <sub>G</sub> =330Ω	I	—	1.5	V
V <sub>RGT I</sub>			II	—	1.5	V
V <sub>RGT III</sub>			III	—	1.5	V
I <sub>FGT I</sub>	Gate trigger current *2	T <sub>j</sub> =25°C, V <sub>D</sub> =6V, R <sub>L</sub> =6Ω, R <sub>G</sub> =330Ω	I	—	30	mA
I <sub>RGT I</sub>			II	—	30	mA
I <sub>RGT III</sub>			III	—	30	mA
V <sub>GD</sub>	Gate non-trigger voltage	T <sub>j</sub> =125°C, V <sub>D</sub> =1/2V <sub>DRM</sub>	0.2	—	—	V
R <sub>th(j-e)</sub>	Thermal resistance	Junction to case (BCR20A, BCR20B, BCR20C)	—	—	1.1	°C/W
R <sub>th(j-b)</sub>		Junction to base (BCR20E)	—	—	2.4	°C/W
(dv/dt) <sub>c</sub>	Critical-rate of rise of off-state commutating voltage		*3	—	—	V/μs

\*2. Measurement using the gate trigger characteristics measurement circuit.

\*3. The critical-rate of rise of the off-state commutating voltage is shown in the table below.

Voltage class	V <sub>DRM</sub> (V)	(dv/dt) <sub>c</sub>			Test conditions	Commutating voltage and current waveforms (inductive load)
		Symbol	Min.	Unit		
8	400	R	—	V/μs	1. Junction temperature T <sub>j</sub> =125°C 2. Rate of decay of on-state commutating current (di/dt) <sub>c</sub> =-10A/ms 3. Peak off-state voltage V <sub>D</sub> =400V	
		L	10			
10	600	R	—			
		L	10			

# BCR20A, BCR20B, BCR20C, BCR20E

MEDIUM POWER USE

A, B, C : NON-INSULATED TYPE, E : INSULATED TYPE, GLASS PASSIVATION TYPE

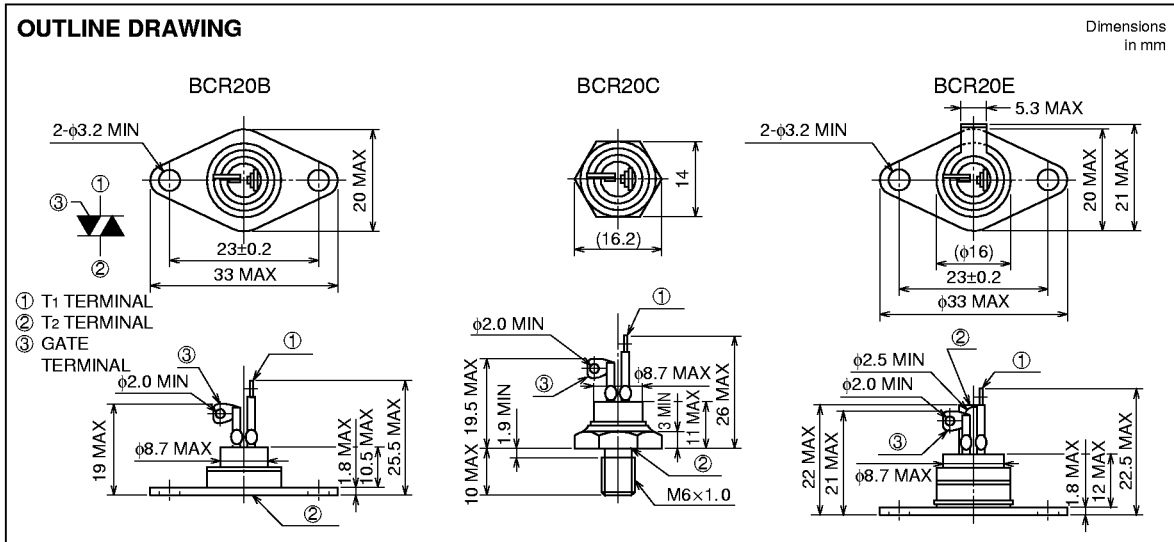

### PERFORMANCE CURVES

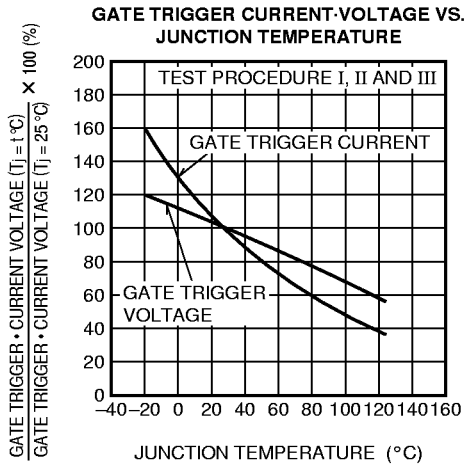
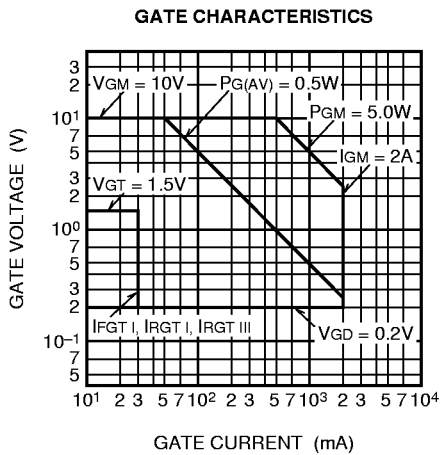
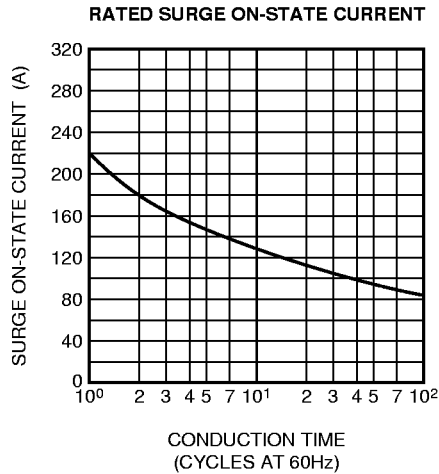
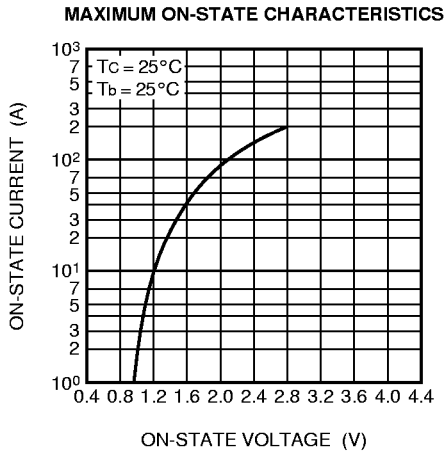

# BCR20A, BCR20B, BCR20C, BCR20E

MEDIUM POWER USE

A, B, C : NON-INSULATED TYPE, E : INSULATED TYPE, GLASS PASSIVATION TYPE

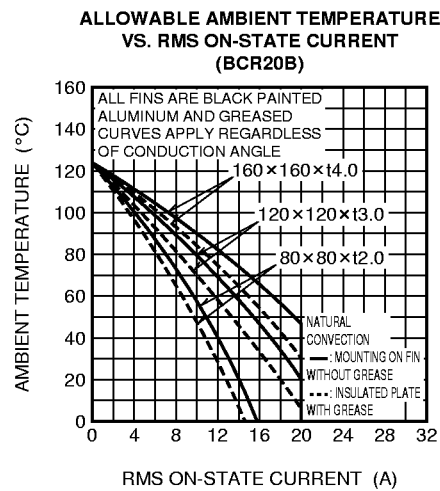
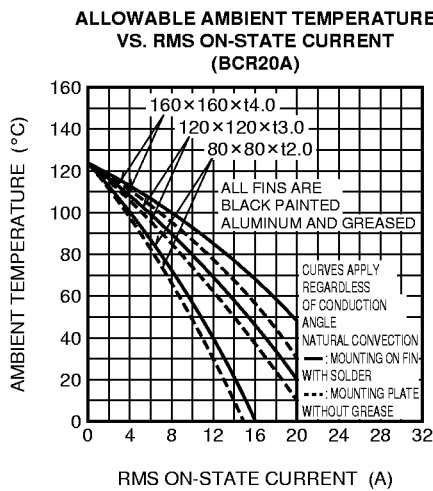
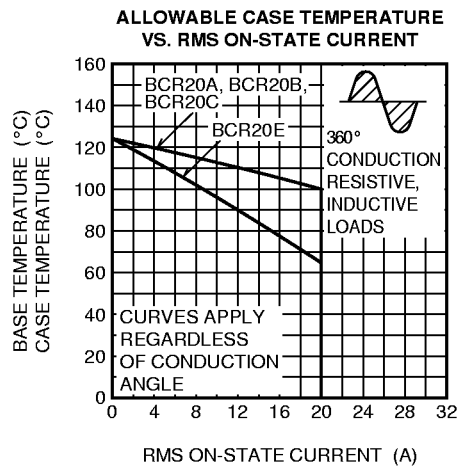
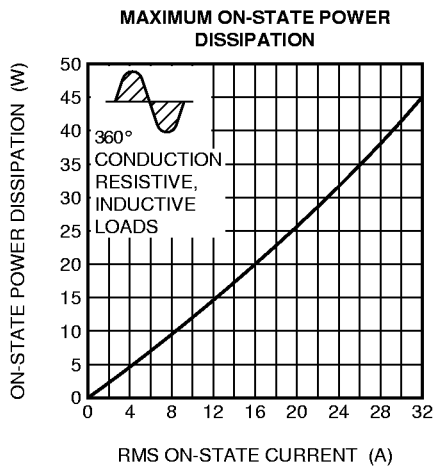
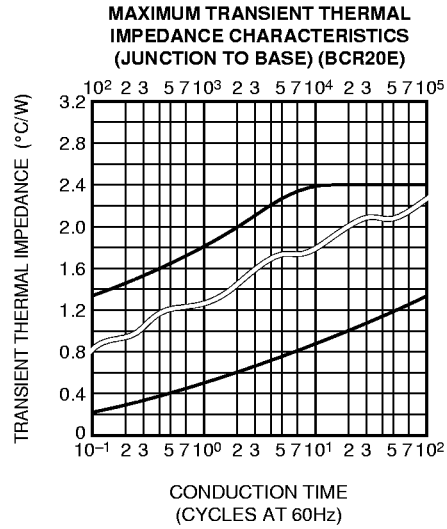
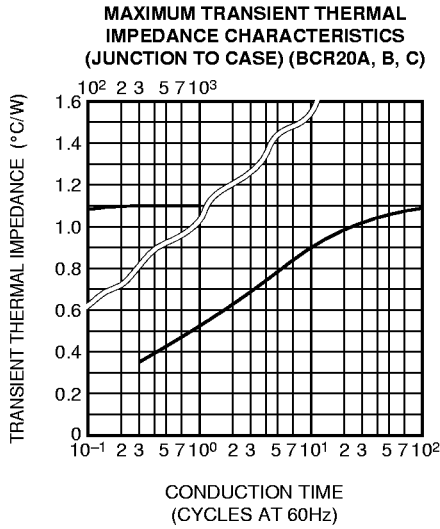

# BCR20A, BCR20B, BCR20C, BCR20E

MEDIUM POWER USE

A, B, C : NON-INSULATED TYPE, E : INSULATED TYPE, GLASS PASSIVATION TYPE

**ALLOWABLE AMBIENT TEMPERATURE VS. RMS ON-STATE CURRENT (BCR20C)**

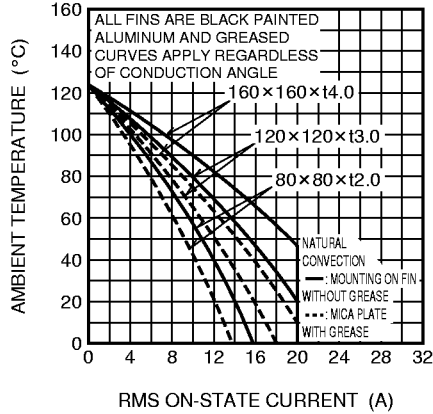

**ALLOWABLE AMBIENT TEMPERATURE VS. RMS ON-STATE CURRENT (BCR20E)**

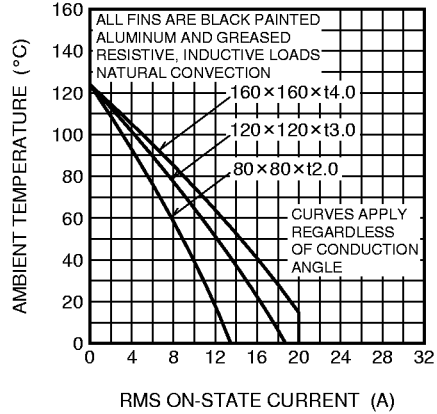

**GATE TRIGGER CHARACTERISTICS TEST CIRCUITS**

