

**4M-BIT Bi-CMOS SYNCHRONOUS FAST STATIC RAM
256K-WORD BY 18-BIT / 128K-WORD BY 36-BIT
LVTTTL INTERFACE/REGISTER-LATCH/LATE WRITE**

Description

The μ PD464518AL is a 262,144 words by 18 bits, and the μ PD464536AL is a 131,072 words by 36 bits synchronous static RAM fabricated with advanced Bi-CMOS technology using N-channel memory cell.

This technology and unique peripheral circuits make the μ PD464518AL and μ PD464536AL a high-speed device. The μ PD464518AL and μ PD464536AL are suitable for applications which require high-speed, low voltage, high-density memory and wide bit configuration, such as cache and buffer memory.

These are packaged in a 119-pin plastic BGA (Ball Grid Array).

Features

- Register to latch synchronous operation
- LVTTTL 3.3 V Input / Output levels
- Fast clock access time : 5.5 ns / 182 MHz, 6.0 ns / 166 MHz, 7.0 ns / 143 MHz
- Asynchronous output enable control : /G
- Single differential clock inputs
- Byte write control : /SBa (DQa1-9), /SBb (DQb1-9), /SBc (DQc1-9), /SBd (DQd1-9)
- Common I/O using three-state outputs
- Internally self-timed write cycle
- Late write with 1 dead cycle between Read-Write
- Boundary scan (JTAG) IEEE 1149.1 compatible
- Single +3.3 V power supply
- Sleep mode : ZZ(Enables sleep mode, active high)

Ordering Information

Part number	Access time	Clock frequency	Package
μ PD464518ALS1-A55	5.5 ns	182 MHz	119-pin plastic BGA
μ PD464518ALS1-A6	6.0 ns	166 MHz	
μ PD464518ALS1-A7	7.0 ns	143 MHz	
μ PD464536ALS1-A55	5.5 ns	182 MHz	
μ PD464536ALS1-A6	6.0 ns	166 MHz	
μ PD464536ALS1-A7	7.0 ns	143 MHz	

The information in this document is subject to change without notice. Before using this document, please confirm that this is the latest version.
Not all devices/types available in every country. Please check with local NEC representative for availability and additional information.

Pin Configurations

/xxx indicates active low signal.

119-pin Plastic BGA (256K Words by 18 Bits Pin Assignment)
[μPD464518ALS1]

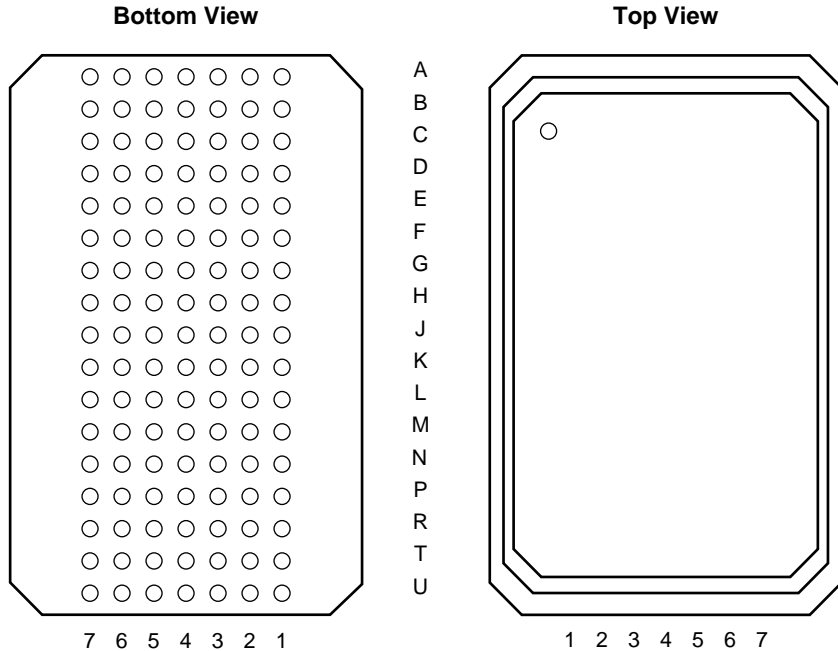

7	6	5	4	3	2	1
V _{DDQ}	SA2	SA6	NC	SA9	SA12	V _{DDQ}
NC	NC	SA16	NC	SA17	NC	NC
NC	SA3	SA7	V _{DD}	SA10	SA13	NC
NC	DQa9	V _{SS}	NC	V _{SS}	NC	DQb1
DQa8	NC	V _{SS}	/SS	V _{SS}	DQb2	NC
V _{DDQ}	DQa7	V _{SS}	/G	V _{SS}	NC	V _{DDQ}
DQa6	NC	V _{SS}	NC	/SBb	DQb3	NC
NC	DQa5	V _{SS}	NC	V _{SS}	NC	DQb4
V _{DDQ}	V _{DD}	NC	V _{DD}	NC	V _{DD}	V _{DDQ}
DQa4	NC	V _{SS}	K	V _{SS}	DQb5	NC
NC	DQa3	/SBa	/K	V _{SS}	NC	DQb6
V _{DDQ}	NC	V _{SS}	/SW	V _{SS}	DQb7	V _{DDQ}
NC	DQa2	V _{SS}	SA1	V _{SS}	NC	DQb8
DQa1	NC	V _{SS}	SA0	V _{SS}	DQb9	NC
NC	SA4	V _{SS}	V _{DD}	V _{DD}	SA14	NC
ZZ	SA5	SA8	NC	SA11	SA15	NC
V _{DDQ}	NC	TDO	TCK	TDI	TMS	V _{DDQ}

A	1	2	3	4	5	6	7
A	V _{DDQ}	SA12	SA9	NC	SA6	SA2	V _{DDQ}
B	NC	NC	SA17	NC	SA16	NC	NC
C	NC	SA13	SA10	V _{DD}	SA7	SA3	NC
D	DQb1	NC	V _{SS}	NC	V _{SS}	DQa9	NC
E	NC	DQb2	V _{SS}	/SS	V _{SS}	NC	DQa8
F	V _{DDQ}	NC	V _{SS}	/G	V _{SS}	DQa7	V _{DDQ}
G	NC	DQb3	/SBb	NC	V _{SS}	NC	DQa6
H	DQb4	NC	V _{SS}	NC	V _{SS}	DQa5	NC
J	V _{DDQ}	V _{DD}	NC	V _{DD}	NC	V _{DD}	V _{DDQ}
K	NC	DQb5	V _{SS}	K	V _{SS}	NC	DQa4
L	DQb6	NC	V _{SS}	/K	/SBa	DQa3	NC
M	V _{DDQ}	DQb7	V _{SS}	/SW	V _{SS}	NC	V _{DDQ}
N	DQb8	NC	V _{SS}	SA1	V _{SS}	DQa2	NC
P	NC	DQb9	V _{SS}	SA0	V _{SS}	NC	DQa1
R	NC	SA14	V _{DD}	V _{DD}	V _{SS}	SA4	NC
T	NC	SA15	SA11	NC	SA8	SA5	ZZ
U	V _{DDQ}	TMS	TDI	TCK	TDO	NC	V _{DDQ}

Pin Name and Functions [μPD464518ALS1]

Pin name	Description	Function
VDD	Core Power Supply	Supplies power for RAM core
VSS	Ground	
VDDQ	Output Power Supply	Supplies power for output buffers
K, /K	Main Clock Input	
SA0 to SA17	Synchronous Address Input	
DQa1 to DQb9	Synchronous Data Input / Output	
/SS	Synchronous Chip Select	Logically selects SRAM
/SW	Synchronous Byte Write Enable	Write command
/SBa	Synchronous Byte "a" Write Enable	Write DQa1 to DQa9
/SBb	Synchronous Byte "b" Write Enable	Write DQb1 to DQb9
/G	Asynchronous Output Enable	Asynchronous input
ZZ	Sleep Mode Enable	Enables sleep mode, active high
NC	No Connection	
TMS	Test Mode Select (JTAG)	
TDI	Test Data Input (JTAG)	
TCK	Test Clock Input (JTAG)	
TDO	Test Data Output (JTAG)	

119-pin plastic BGA (128K Words by 36 Bits Pin Assignment)
[μPD464536ALS1]

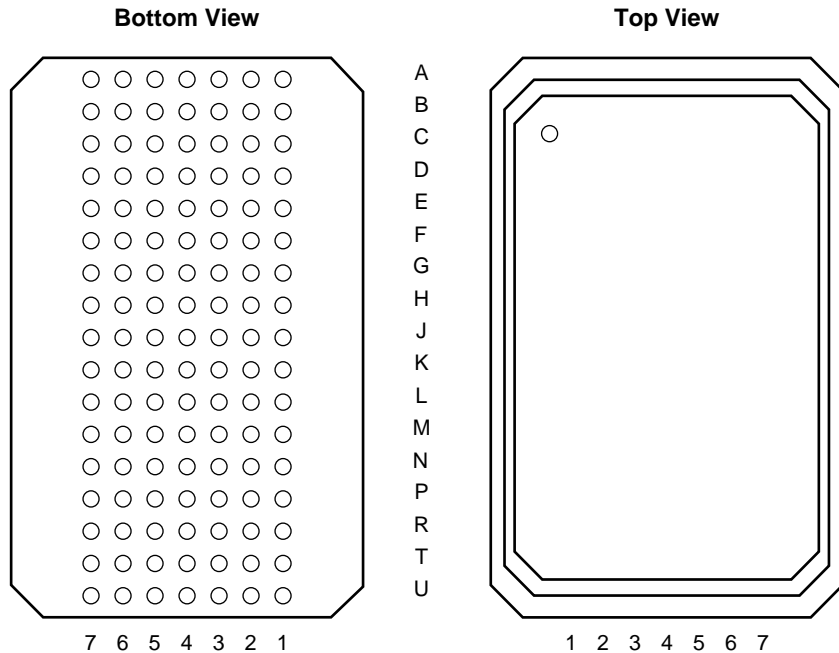

7	6	5	4	3	2	1
V _{DDQ}	SA2	SA5	NC	SA9	SA12	V _{DDQ}
NC	NC	SA15	NC	SA16	NC	NC
NC	SA3	SA6	V _{DD}	SA10	SA13	NC
DQb8	DQb9	V _{SS}	NC	V _{SS}	DQc9	DQc8
DQb6	DQb7	V _{SS}	/SS	V _{SS}	DQc7	DQc6
V _{DDQ}	DQb5	V _{SS}	/G	V _{SS}	DQc5	V _{DDQ}
DQb3	DQb4	/SBb	NC	/SBc	DQc4	DQc3
DQb1	DQb2	V _{SS}	NC	V _{SS}	DQc2	DQc1
V _{DDQ}	V _{DD}	NC	V _{DD}	NC	V _{DD}	V _{DDQ}
DQa1	DQa2	V _{SS}	K	V _{SS}	DQd2	DQd1
DQa3	DQa4	/SBa	/K	/SBd	DQd4	DQd3
V _{DDQ}	DQa5	V _{SS}	/SW	V _{SS}	DQd5	V _{DDQ}
DQa6	DQa7	V _{SS}	SA1	V _{SS}	DQd7	DQd6
DQa8	DQa9	V _{SS}	SA0	V _{SS}	DQd9	DQd8
NC	SA4	V _{SS}	V _{DD}	V _{DD}	SA14	NC
ZZ	NC	SA7	SA8	SA11	NC	NC
V _{DDQ}	NC	TDO	TCK	TDI	TMS	V _{DDQ}

	1	2	3	4	5	6	7
A	V _{DDQ}	SA12	SA9	NC	SA5	SA2	V _{DDQ}
B	NC	NC	SA16	NC	SA15	NC	NC
C	NC	SA13	SA10	V _{DD}	SA6	SA3	NC
D	DQc8	DQc9	V _{SS}	NC	V _{SS}	DQb9	DQb8
E	DQc6	DQc7	V _{SS}	/SS	V _{SS}	DQb7	DQb6
F	V _{DDQ}	DQc5	V _{SS}	/G	V _{SS}	DQb5	V _{DDQ}
G	DQc3	DQc4	/SBc	NC	/SBb	DQb4	DQb3
H	DQc1	DQc2	V _{SS}	NC	V _{SS}	DQb2	DQb1
J	V _{DDQ}	V _{DD}	NC	V _{DD}	NC	V _{DD}	V _{DDQ}
K	DQd1	DQd2	V _{SS}	K	V _{SS}	DQa2	DQa1
L	DQd3	DQd4	/SBd	/K	/SBa	DQa4	DQa3
M	V _{DDQ}	DQd5	V _{SS}	/SW	V _{SS}	DQa5	V _{DDQ}
N	DQd6	DQd7	V _{SS}	SA1	V _{SS}	DQa7	DQa6
P	DQd8	DQd9	V _{SS}	SA0	V _{SS}	DQa9	DQa8
R	NC	SA14	V _{DD}	V _{DD}	V _{SS}	SA4	NC
T	NC	NC	SA11	SA8	SA7	NC	ZZ
U	V _{DDQ}	TMS	TDI	TCK	TDO	NC	V _{DDQ}

Pin Name and Functions [μPD464536ALS1]

Pin name	Description	Function
VDD	Core Power Supply	Supplies power for RAM core
VSS	Ground	
VDDQ	Output Power Supply	Supplies power for output buffers
K, /K	Main Clock	
SA0 to SA16	Synchronous Address Input	
DQa1 to DQd9	Synchronous Data Input / Output	
/SS	Synchronous Chip Select	Logically selects SRAM
/SW	Synchronous Byte Write Enable	Write command
/SBa	Synchronous Byte "a" Write Enable	Write DQa1 to DQa9
/SBb	Synchronous Byte "b" Write Enable	Write DQb1 to DQb9
/SBc	Synchronous Byte "c" Write Enable	Write DQc1 to DQc9
/SBd	Synchronous Byte "d" Write Enable	Write DQd1 to DQd9
/G	Asynchronous Output Enable	Asynchronous input
ZZ	Sleep Mode Enable	Enables sleep mode, active high
NC	No Connection	
TMS	Test Mode Select (JTAG)	
TDI	Test Data Input (JTAG)	
TCK	Test Clock Input (JTAG)	
TDO	Test Data Output (JTAG)	

Late Write Block Diagram

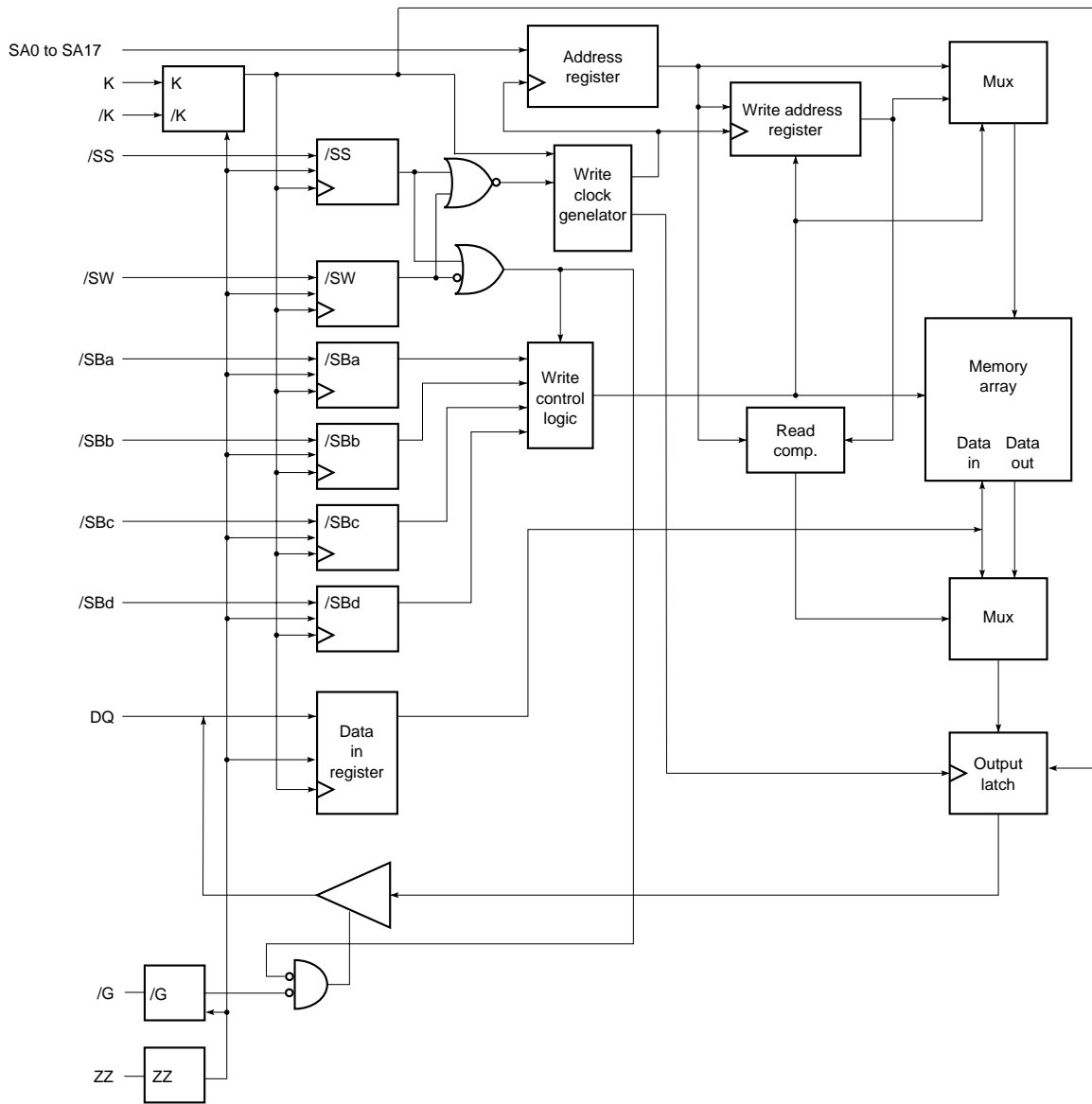

Synchronous Truth Table

ZZ	/SS	/SW	/SBa	/SBb	/SBc	/SBd	Mode	DQa1-9	DQb1-9	DQc1-9	DQd1-9	Power
L	H	×	×	×	×	×	Not selected	Hi-Z	Hi-Z	Hi-Z	Hi-Z	Active
L	L	H	×	×	×	×	Read	Dout	Dout	Dout	Dout	Active
L	L	L	L	L	L	L	Write	Din	Din	Din	Din	Active
L	L	L	L	H	H	H	Write	Din	Hi-Z	Hi-Z	Hi-Z	Active
L	L	L	H	L	L	L	Write	Hi-Z	Din	Din	Din	Active
H	×	×	×	×	×	×	Sleep Mode	Hi-Z	Hi-Z	Hi-Z	Hi-Z	Standby

Remark × : Don't care

Output Enable Truth Table

Mode	/G	DQ
Read	L	Dout
Read	H	Hi-Z
Sleep (ZZ=H)	×	Hi-Z
Write (/SW=L)	×	Hi-Z
Deselect (/SS=H)	×	Hi-Z

Remark × : Don't care

Electrical Specifications

Absolute Maximum Ratings

Parameter	Symbol	Condition	MIN.	TYP.	MAX.	Unit	Note
Supply voltage	V _{DD}		-0.5		+4	V	1
Output supply voltage	V _{DDQ}		-0.5		+4	V	1
Input voltage	V _{IN}		-0.5		V _{DD} +0.5	V	1
Input / Output voltage	V _{I/O}		-0.5		V _{DD} +0.5	V	1
Operating temperature	T _j		5		110	°C	2
Storage temperature	T _{stg}		-55		+125	°C	

- Notes**
1. -1.0 V MIN. (Pulse width 10% T_{cyc})
 2. T_j = Junction temperature

Caution Exposing the device to stress above those listed in Absolute Maximum Rating could cause permanent damage. The device is not meant to be operated under conditions outside the limits described in the operational section of this specification. Exposure to Absolute Maximum Rating conditions for extended periods may affect device reliability.

Recommended DC Operating Conditions (T_j = 5 to 110 °C)

Parameter	Symbol	Conditions	MIN.	TYP.	MAX.	Unit
Core supply voltage	V _{DD}		3.15	3.3	3.45	V
Output buffer supply voltage	V _{DDQ}		3.15	3.3	3.45	V
Low level input voltage	V _{IL}		-0.3 ^{Note}		+0.8	V
High level input voltage	V _{IH}		2.0		V _{DD} +0.3	V
Clock input differential voltage	V _{DIF} (DC)		0.2		V _{DD} +0.6	V
Clock input common mode voltage range	V _{CM} (DC)		1.3		2.1	V

Note -1.0 V MIN. (Pulse width 10% T_{cyc})

Remark V_{DIF(DC)} and V_{CM(DC)} are as follows:

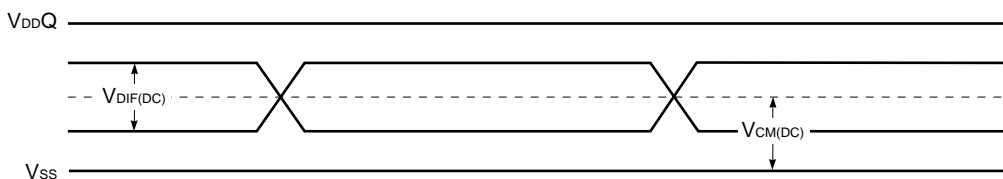

Capacitance (T_A = 25°C, f = 1 MHz)

Parameter ^{Note}	Symbol	Test conditions	MAX.	Unit
Input capacitance	C _{IN}	V _{IN} = 0 V	6	pF
Input / Output capacitance	C _{I/O}	V _{I/O} = 0 V	7	pF

Note These parameters are sampled and not 100% tested.

DC Characteristics (Recommended Operating Conditions Unless Otherwise Noted)

Parameter	Symbol	Conditions	MIN.	TYP.	MAX.	Unit	Note	
Input leakage current	I _{LI}	V _{IN} = 0 to V _{DD}	-5		+5	μ A		
DQ leakage current	I _{LO}	V _{I/O} = 0 to V _{DDQ} , /SS = V _{IH} or /G = V _{IH}	-5		+5	μ A		
Operating supply current	I _{CC}	/SS = V _{IL} cycle = 182 MHz, I _{DQ} = 0 mA	μ PD464518AL			450	mA	
			μ PD464536AL			650		
Sleep mode power supply current	I _{SBZZ}	ZZ = V _{IH} , All other inputs = V _{IH} or V _{IL} cycle = DC, I _{DQ} = 0 mA				45	mA	
Power supply standby current	I _{SBSS}	V _{IN} = V _{IH} or V _{IL} , /SS = V _{IH} , ZZ = V _{IL} cycle = 182 MHz, I _{DQ} = 0 mA	μ PD464518AL			430	mA	
			μ PD464536AL			630		
Low level output voltage	V _{OL}	I _{OL} = 8 mA				0.4	V	1
High level output voltage	V _{OH}	I _{OH} = -5 mA	2.4				V	1

Note 1. See figure.

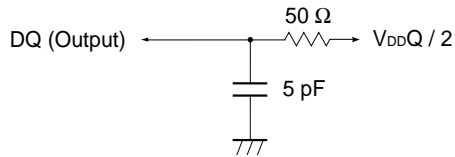

AC Characteristics (Recommended Operating Conditions Unless Otherwise Noted)

AC Characteristics Test Conditions

Input waveform (rise / fall time = 0.5 ns (20 to 80%))

K, /K signals

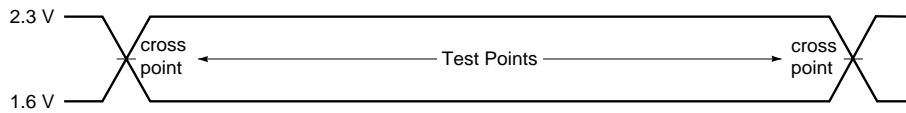

Other signals

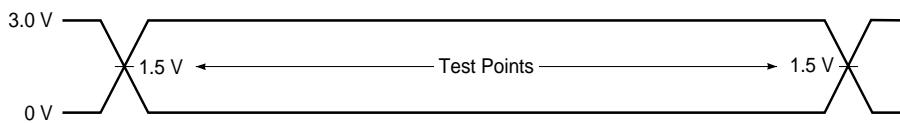

Output waveform

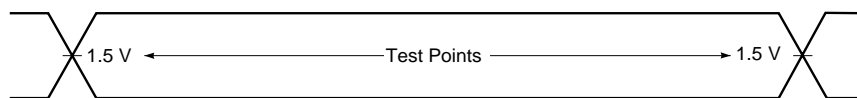

Output load

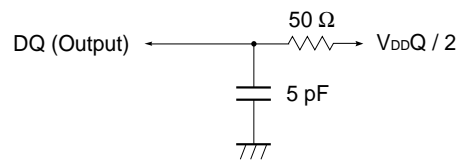
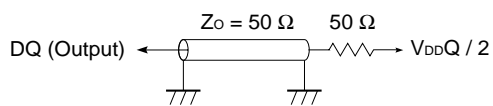

Single Differential Clock, Registered Input / Latched Output Mode

Parameter		Symbol	-A55 (182 MHz)		-A6 (166 MHz)		-A7 (143 MHz)		Unit	Notes
			MIN.	MAX.	MIN.	MAX.	MIN.	MAX.		
Clock cycle time		t _{KHKH}	5.5	–	6.0	–	7.0	–	ns	
Clock phase time		t _{KHKL} / t _{KLKH}	1.8	–	2.0	–	2.5	–	ns	
Setup times	Address	t _{AVKH}	0.5	–	0.5	–	0.5	–	ns	
	Write data	t _{DVKH}								
	Write enable	t _{WVKH}								
	Chip select	t _{SVKH}								
Hold times	Address	t _{KHAX}	1.0	–	1.0	–	1.0	–	ns	
	Write data	t _{KHDX}								
	Write enable	t _{KHWX}								
	Chip select	t _{KHSX}								
Clock access time		t _{KHQV}	–	5.5	–	6.0	–	7.0	ns	1
K low to Q valid		t _{KLQV}	–	3.0	–	3.0	–	3.5	ns	1
K low to Q change		t _{KLQX}	0.7	–	0.7	–	0.7	–	ns	1
/G low to Q valid		t _{GLQV}	–	3.0	–	3.0	–	3.5	ns	1
/G low to Q change		t _{GLQX}	0.7	–	0.7	–	0.7	–	ns	1
/G high to Q Hi-Z		t _{GHQZ}	0.7	3.0	0.7	3.0	0.7	3.5	ns	2
K high to Q Hi-Z		t _{KHQZ}	0.7	3.0	0.7	3.0	0.7	3.5	ns	2
K low to Q Lo-Z		t _{KLQX2}	0.7	–	0.7	–	0.7	–	ns	2
Sleep Mode Recovery		t _{ZZR}	5.5	–	6.0	–	7.0	–	ns	
Sleep Mode Enable		t _{ZZE}	–	5.5	–	6.0	–	7.0	ns	

Notes 1. See figure.

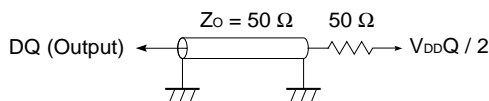

2. See figure.

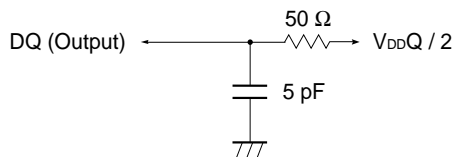

Read Operation

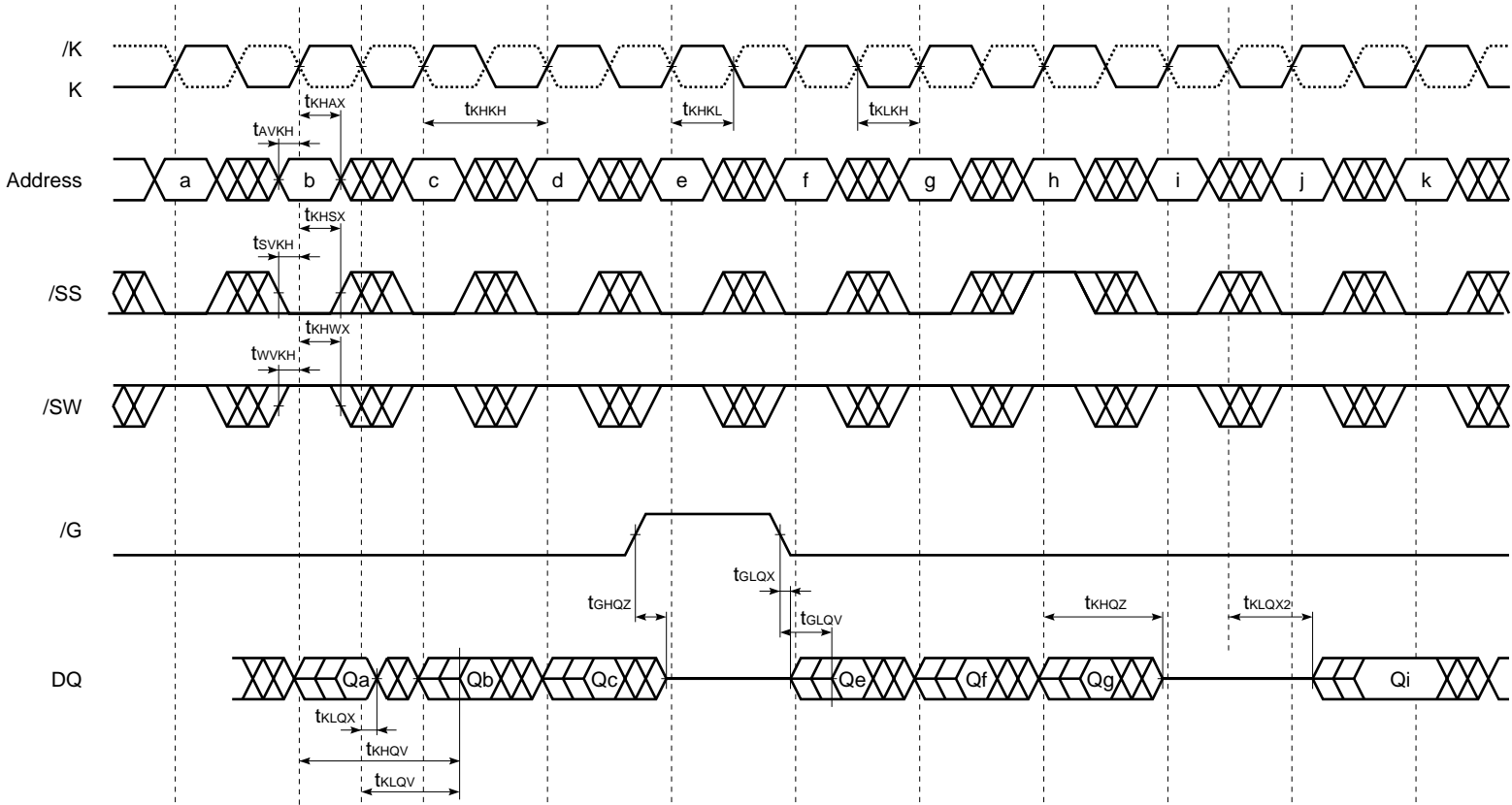

Write Operation

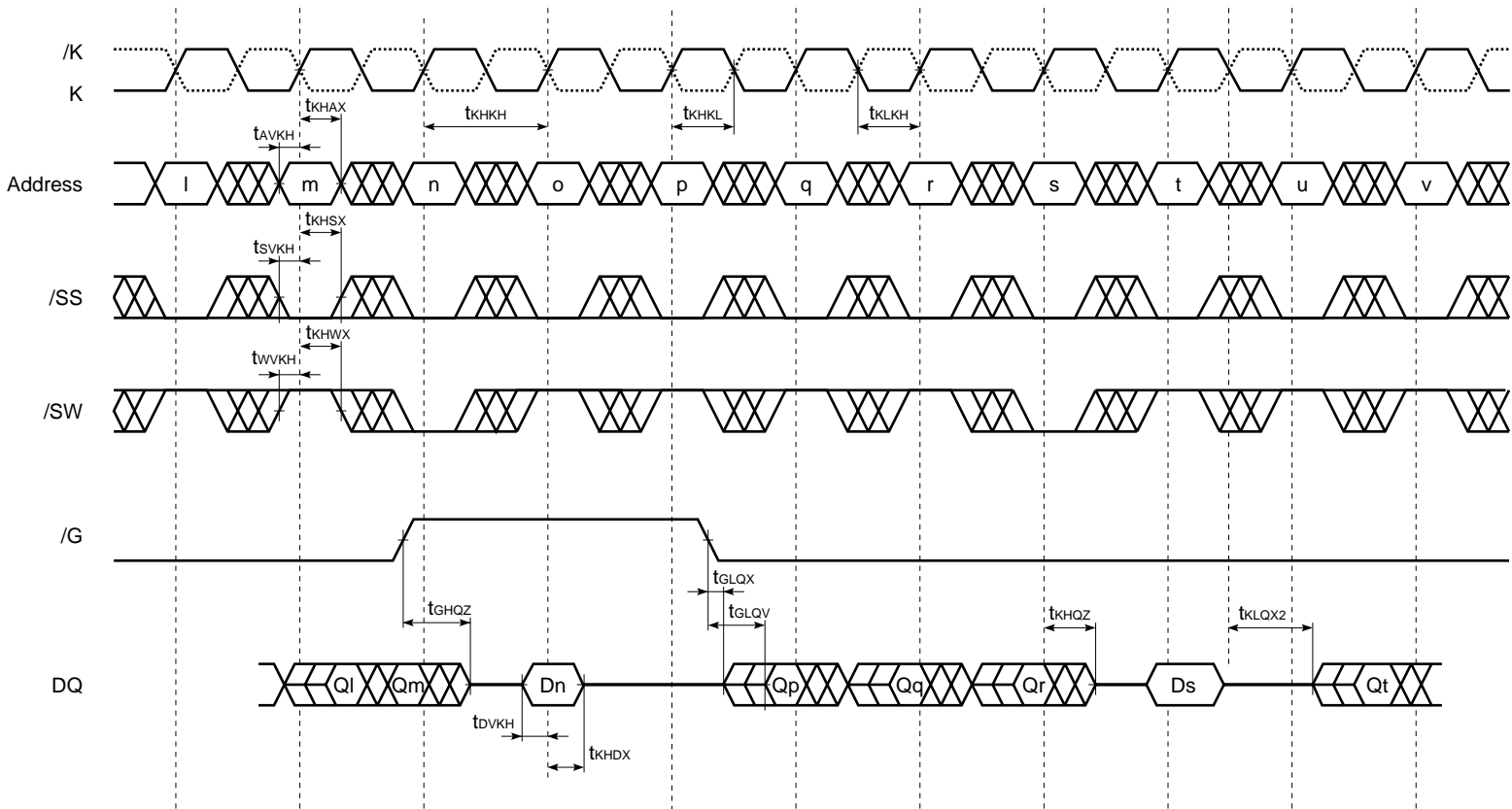

Sleep Mode

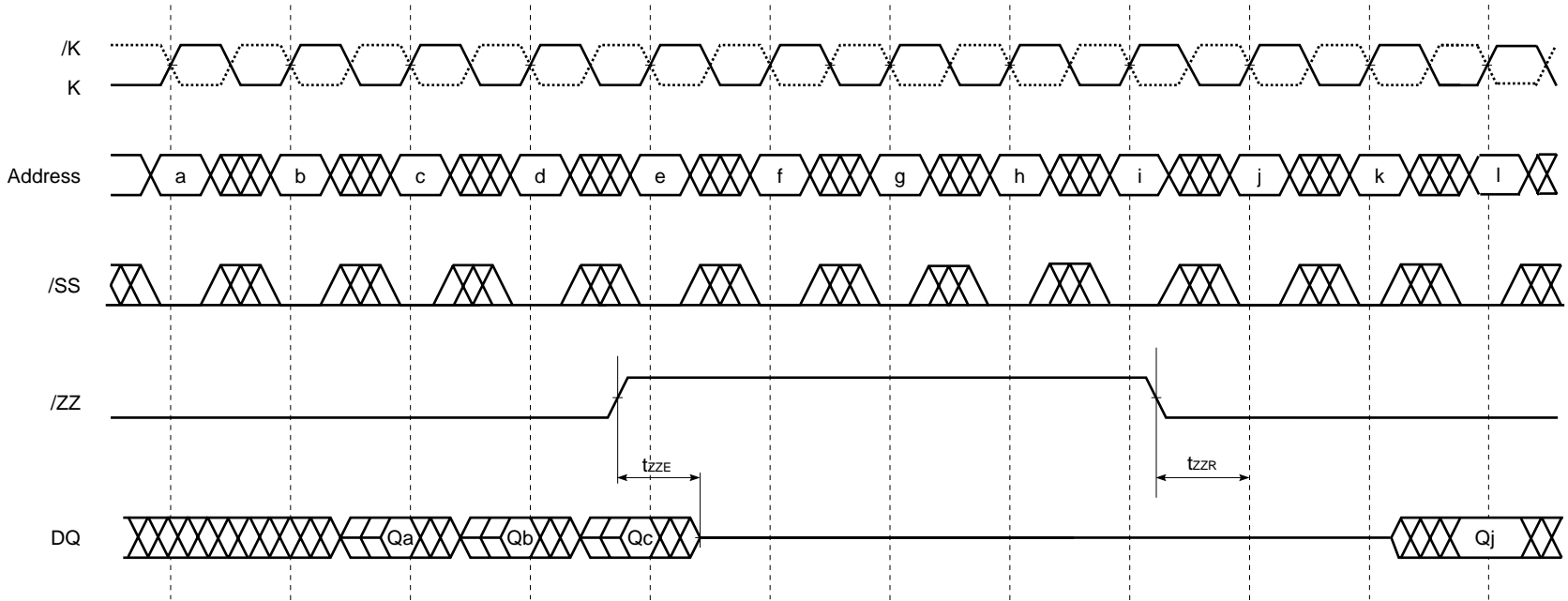

JTAG Specification

The μPD464518AL and μPD464536AL support a limited set of JTAG functions as in IEEE standard 1149.1.

Test Access Port (TAP) Pins

Pin Name	Pin Assignments	Description
TCK	4 U	Test Clock Input. All input are captured on the rising edge of TCK and all outputs propagate from the falling edge of TCK.
TMS	2 U	Test Mode Select. This is the command input for the TAP controller state machine.
TDI	3 U	Test Data Input. This is the input side of the serial registers placed between TDI and TDO. The register placed between TDI and TDO is determined by the state of the TAP controller state machine and the instruction that is currently loaded in the TAP instruction.
TDO	5 U	Test Data Output. Output changes in response to the falling edge of TCK. This is the output side of the serial registers placed between TDI and TDO.

Remark The device does not have TRST (TAP reset). The Test-Logic Reset state is entered while TMS is held high for five rising edges of TCK. The TAP controller state is also reset on the SRAM POWER-UP.

JTAG DC Characteristics (T_j = 5 to 110 °C)

Parameter	Symbol	Conditions	MIN.	TYP.	MAX.	Unit	Note
JTAG input high voltage	V _{IH}		2.2		V _{DD} +0.3	V	
JTAG input low voltage	V _{IL}		-0.3		+0.8	V	
JTAG output high voltage	V _{OH}	I _{OH} = -8 mA	2.4		-	V	
JTAG output low voltage	V _{OL}	I _{OL} = 8 mA	-		0.4	V	

JTAG AC Test Conditions ($T_j = 5$ to 110 °C)

Input waveform (rise / fall time = 1 ns (20 to 80 %))

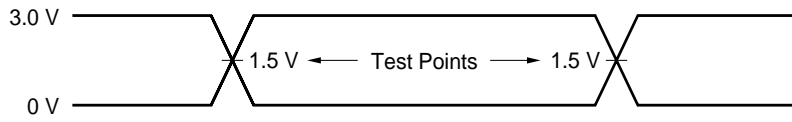

Output waveform

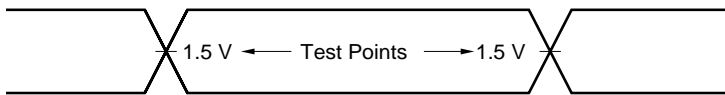

Output load ($V_{TT}=1.5$ V)

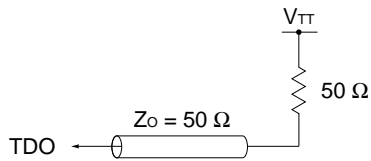

JTAG AC Characteristics (Tj = 5 to 110 °C)

Parameter	Symbol	Conditions	MIN.	TYP.	MAX.	Unit	Note
Clock cycle time (TCK)	t _{THTH}		100		–	ns	
Clock phase time (TCK)	t _{THTL} / t _{TLTH}		40		–	ns	
Setup time (TMS / TDI)	t _{MVTH} / t _{DVTH}		10		–	ns	
Hold time (TMS / TDI)	t _{THMX} / t _{THDX}		10		–	ns	
TCK low to TDO valid (TDO)	t _{TLQV}		–		20	ns	

JTAG Timing Diagram

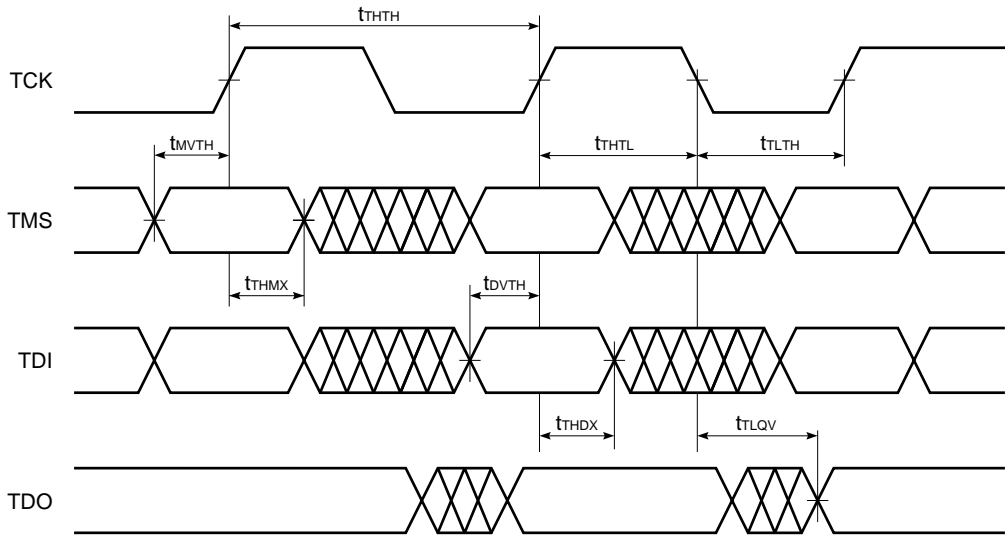

Scan Register Definition (1)

Register name	Description
Instruction register	The instruction register holds the instructions that are executed by the TAP controller when it is moved into the run-test/idle or the various data register state. The register can be loaded when it is placed between the TDI and TDO pins. The instruction register is automatically preloaded with the IDCODE instruction at power-up whenever the controller is placed in test-logic-reset state.
Bypass register	The bypass register is a single bit register that can be placed between TDI and TDO. It allows serial test data to be passed through the RAMs TAP to another device in the scan chain with as little delay as possible.
ID register	The ID Register is a 32 bit register that is loaded with a device and vendor specific 32 bit code when the controller is put in capture-DR state with the IDCODE command loaded in the instruction register. The register is then placed between the TDI and TDO pins when the controller is moved into shift-DR state.
Boundary register	The boundary register, under the control of the TAP controller, is loaded with the contents of the RAMs I/O ring when the controller is in capture-DR state and then is placed between the TDI and TDO pins when the controller is moved to shift-DR state. Several TAP instructions can be used to activate the boundary register. The Scan Exit Order tables describe which device bump connects to each boundary register location. The first column defines the bit's position in the boundary register. The shift register bit nearest TDO (i.e., first to be shifted out) is defined as bit 1. The second column is the name of the input or I/O at the bump and the third column is the bump number.

Scan Register Definition (2)

Register name	μPD464518AL	μPD464536AL	Unit
Instruction register	3	3	bit
Bypass register	1	1	bit
ID register	32	32	bit
Boundary register	51	70	bit

ID Register Definition

Part number	Organization	ID [31:28] vendor revision no.	ID [27:12] part no.	ID [11:1] vendor ID no.	ID [0] fix bit
μPD464518AL	256K x 18	XXXX	0110001011 101000	00010010000	1
μPD464536AL	128K x 36	XXXX	0110101100 101000	00010010000	1

SCAN Exit Order

[μPD464518AL (256K words by 18 bits)]

Bit no.	Signal name	Bump ID
1	M2	5R
2	SA5	6T
3	SA0	4P
4	SA4	6R
5	SA8	5T
6	ZZ	7T
7	DQa1	7P
8	DQa2	6N
9	DQa3	6L
10	DQa4	7K
11	/SBa	5L
12	/K	4L
13	K	4K
14	/G	4F
15	DQa5	6H
16	DQa6	7G
17	DQa7	6F
18	DQa8	7E
19	DQa9	6D
20	SA2	6A
21	SA3	6C
22	SA7	5C
23	SA6	5A
24	NC	6B
25	SA16	5B
26	SA17	3B
27	NC	2B
28	SA9	3A
29	SA10	3C
30	SA13	2C
31	SA12	2A
32	DQb1	1D
33	DQb2	2E
34	DQb3	2G
35	DQb4	1H
36	/SBb	3G
37	NC	4D
38	/SS	4E
39	NC	4G
40	NC	4H
41	/SW	4M
42	DQb5	2K
43	DQb6	1L
44	DQb7	2M
45	DQb8	1N
46	DQb9	2P
47	SA11	3T
48	SA14	2R
49	SA1	4N
50	SA15	2T
51	M1	3R

[μPD464536AL (128K words by 36 bits)]

Bit no.	Signal name	Bump ID
1	M2	5R
2	SA0	4P
3	SA8	4T
4	SA4	6R
5	SA7	5T
6	ZZ	7T
7	DQa9	6P
8	DQa8	7P
9	DQa7	6N
10	DQa6	7N
11	DQa5	6M
12	DQa4	6L
13	DQa3	7L
14	DQa2	6K
15	DQa1	7K
16	/SBa	5L
17	/K	4L
18	K	4K
19	/G	4F
20	/SBb	5G
21	DQb1	7H
22	DQb2	6H
23	DQb3	7G
24	DQb4	6G
25	DQb5	6F
26	DQb6	7E
27	DQb7	6E
28	DQb8	7D
29	DQb9	6D
30	SA2	6A
31	SA3	6C
32	SA6	5C
33	SA5	5A
34	NC	6B
35	SA15	5B
36	SA16	3B
37	NC	2B
38	SA9	3A
39	SA10	3C
40	SA13	2C
41	SA12	2A
42	DQc9	2D
43	DQc8	1D
44	DQc7	2E
45	DQc6	1E
46	DQc5	2F
47	DQc4	2G
48	DQc3	1G
49	DQc2	2H
50	DQc1	1H
51	/SBc	3G
52	NC	4D
53	/SS	4E
54	NC	4G
55	NC	4H
56	/SW	4M
57	/SBd	3L
58	DQd1	1K
59	DQd2	2K
60	DQd3	1L
61	DQd4	2L
62	DQd5	2M
63	DQd6	1N
64	DQd7	2N
65	DQd8	1P
66	DQd9	2P
67	SA11	3T
68	SA14	2R
69	SA1	4N
70	M1	3R

JTAG Instructions

Instructions	Description
EXTEST	EXTEST is an IEEE 1149.1 mandatory public instruction. It is to be executed whenever the instruction register, whatever length it may be in the device, is loaded with all logic 0s. EXTEST is not implemented in this device. Therefore this device is not 1149.1 compliant. Nevertheless, this RAMs TAP does respond to an all zeros instruction, as follows. With the EXTEST (000) instruction loaded in the instruction register the RAM responds just as it does in response to the SAMPLE instruction, except the RAM output are forced to Hi-Z any time the instruction is loaded.
IDCODE	The IDCODE instruction causes the ID ROM to be loaded into the ID register when the controller is in capture-DR mode and places the ID register between the TDI and TDO pins in shift-DR mode. The IDCODE instruction is the default instruction loaded in at power up and any time the controller is placed in the test-logic-reset state.
BYPASS	The BYPASS instruction is loaded in the instruction register when the bypass register is placed between TDI and TDO. This occurs when the TAP controller is moved to the shift-DR state. This allows the board level scan path to be shortened to facilitate testing of other devices in the scan path.
SAMPLE	Sample is a Standard 1149.1 mandatory public instruction. When the sample instruction is loaded in the instruction register, moving the TAP controller into the capture-DR state loads the data in the RAMs input and I/O buffers into the boundary scan register. Because the RAM clock(s) are independent from the TAP clock (TCK) it is possible for the TAP to attempt to capture the I/O ring contents while the input buffers are in transition (i.e., in a metastable state). Although allowing the TAP to sample metastable input will not harm the device, repeatable results cannot be expected. RAM input signals must be stabilized for long enough to meet the TAPs input data capture setup plus hold time (t_{cs} plus t_{ch}). The RAMs clock inputs need not be paused for any other TAP operation except capturing the I/O ring contents into the boundary scan register. Moving the controller to shift-DR state then places the boundary scan register between the TDI and TDO pins. This functionality is not Standard 1149.1 compliant.
SAMPLE-Z	If the SAMPLE-Z instruction is loaded in the instruction register, all RAM outputs are forced to an inactive drive state (Hi-Z) and the boundary register is connected between TDI and TDO when the TAP controller is moved to the shift-DR state.

JTAG Instruction Cording

IR2	IR1	IR0	Instruction	Note
0	0	0	EXTEST	1
0	0	1	IDCODE	
0	1	0	SAMPLE-Z	1
0	1	1	BYPASS	
1	0	0	SAMPLE	
1	0	1	BYPASS	
1	1	0	BYPASS	
1	1	1	BYPASS	

Note 1. TRISTATE all data drivers and CAPTURE the pad values into a SERIAL SCAN LATCH.

TAP Controller State Diagram

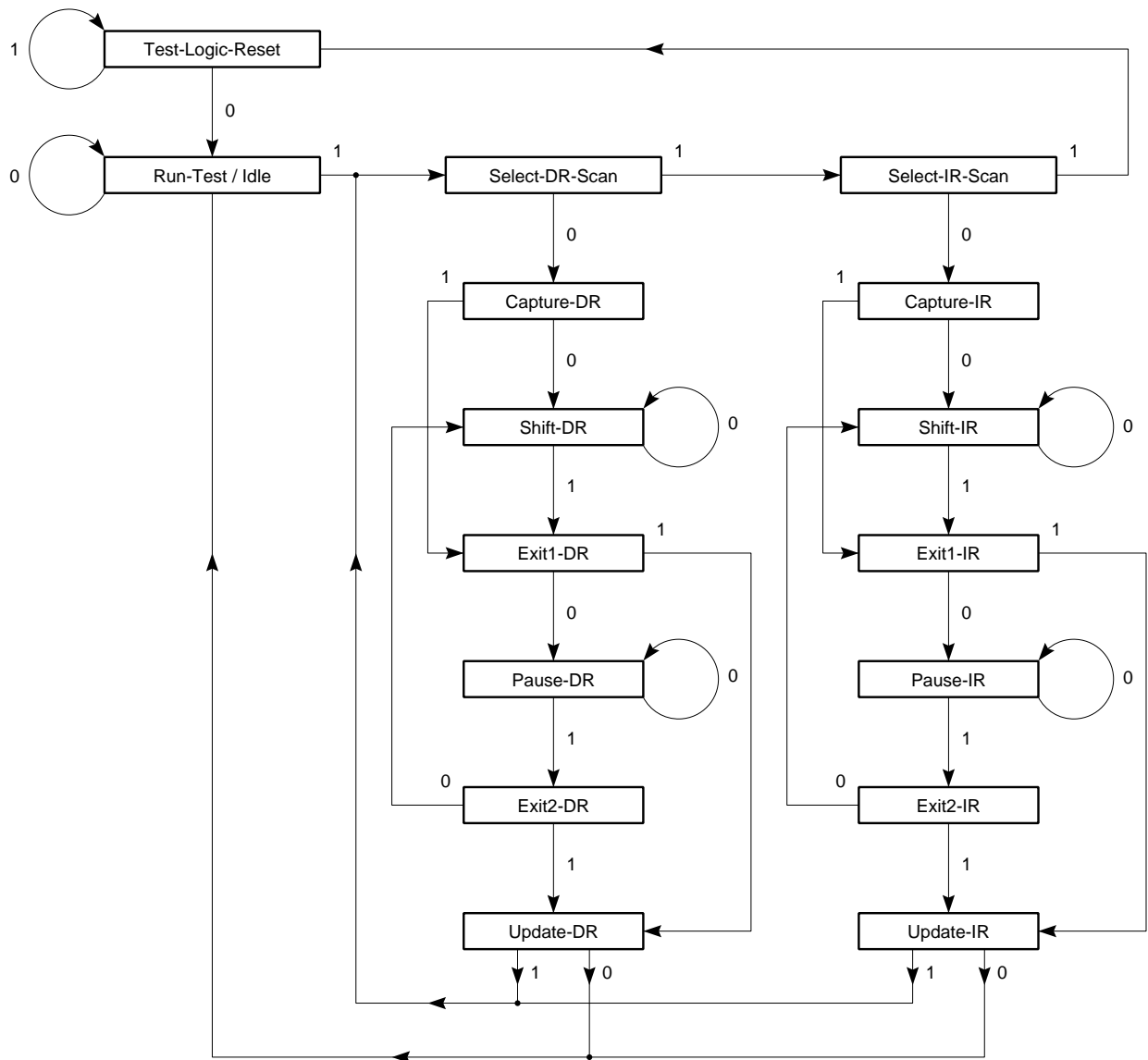

Disabling the Test Access Port

It is possible to use this device without utilizing the TAP. To disable the TAP Controller without interfering with normal operation of the device, TCK must be tied to Vss to preclude mid level inputs.

TDI and TMS are designed so an undriven input will produce a response identical to the application of a logic 1, and may be left unconnected. But they may also be tied to VDD through a 1k resistor.

TDO should be left unconnected.

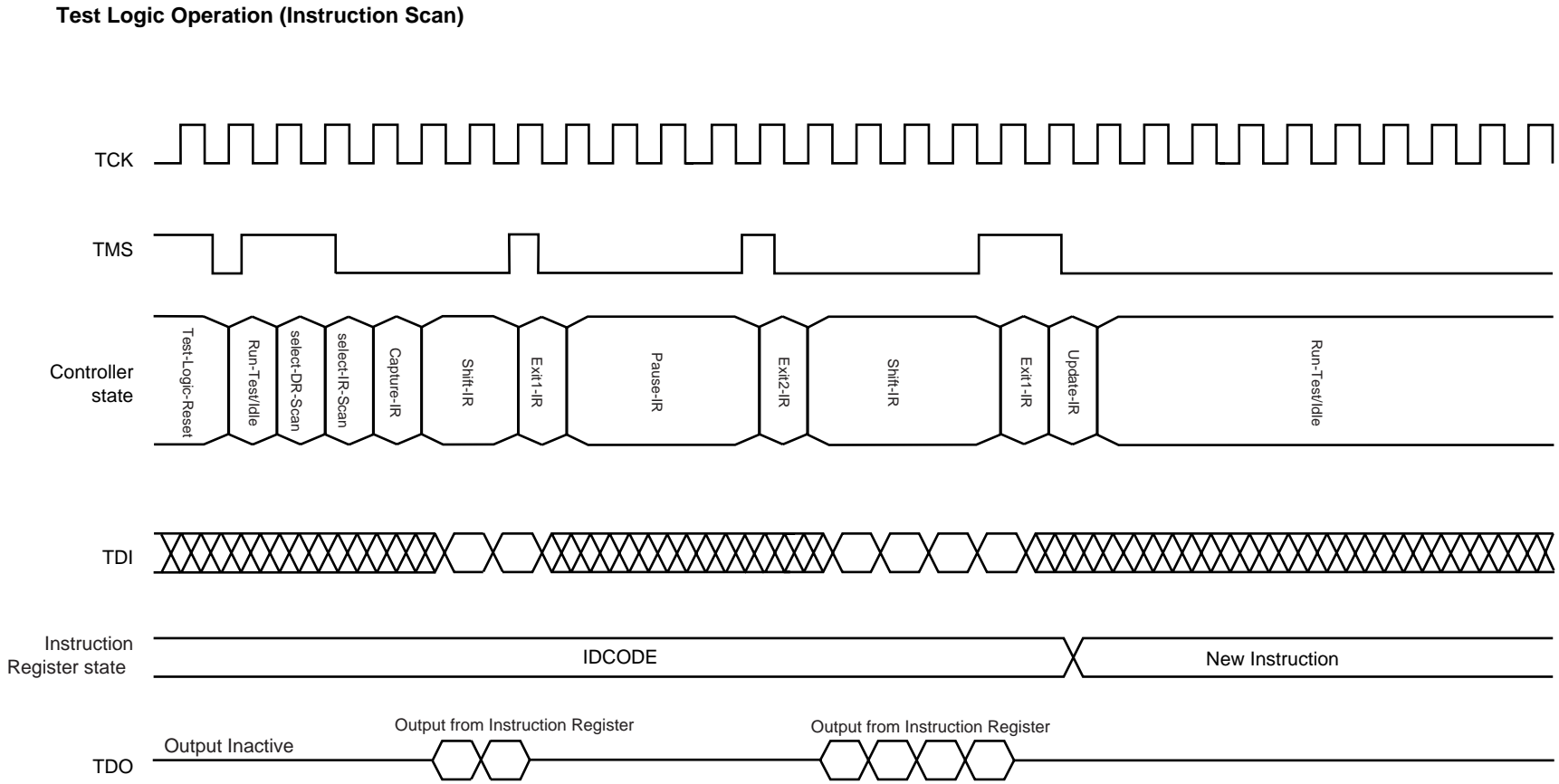

Test Logic Operation (Data Scan)

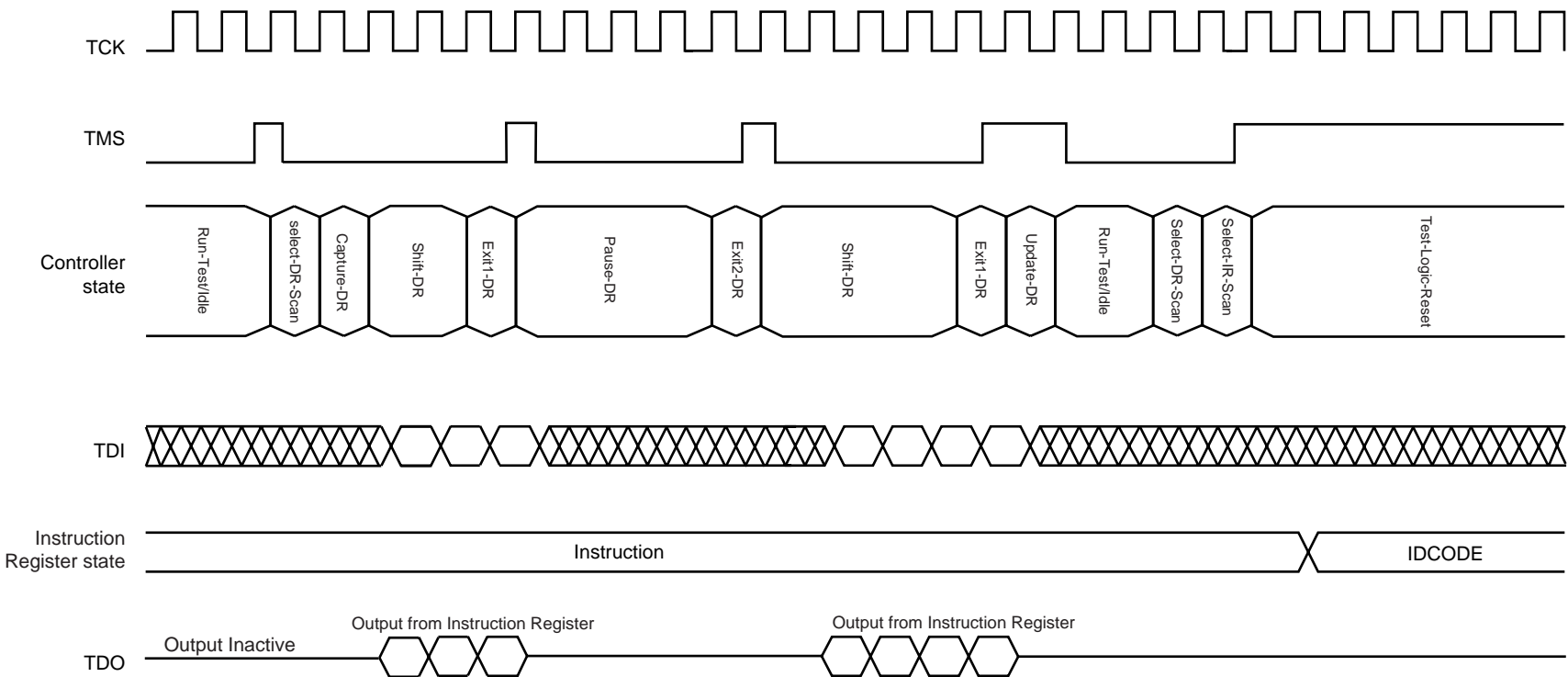

★ Package Drawing

119-PIN PLASTIC BGA

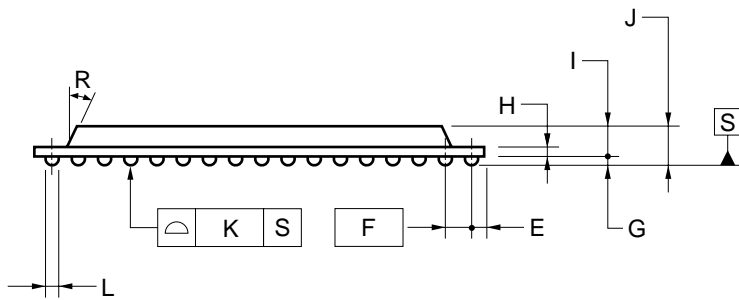
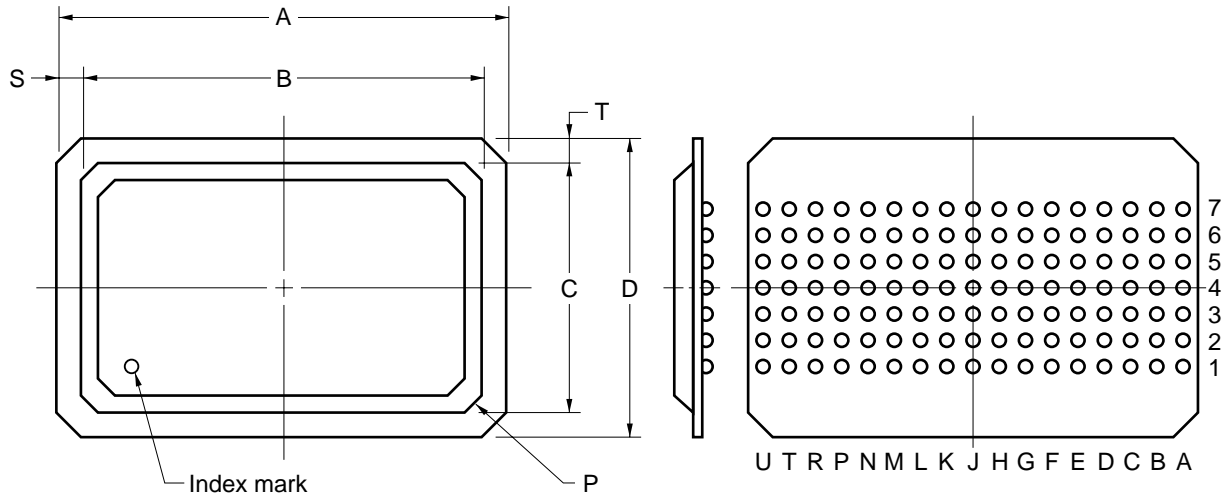

ITEM	MILLIMETERS
A	22.0±0.2
B	19.5
C	12.0
D	14.0±0.2
E	0.84
F	1.27 (T.P.)
G	0.6±0.1
H	0.56
I	1.46±0.1
J	2.30 MAX.
K	0.15
L	φ0.78±0.1
P	C0.7
R	25°
S	1.25
T	1.0

P119S1-127-R4-1

Recommended Soldering Conditions

Please consult with our sales offices for soldering conditions of the μ PD464518AL and μ PD464536AL.

Types of Surface Mount Device

μ PD464518ALS1: 119-pin plastic BGA

μ PD464536ALS1: 119-pin plastic BGA

[MEMO]

NOTES FOR CMOS DEVICES**① PRECAUTION AGAINST ESD FOR SEMICONDUCTORS**

Note:

Strong electric field, when exposed to a MOS device, can cause destruction of the gate oxide and ultimately degrade the device operation. Steps must be taken to stop generation of static electricity as much as possible, and quickly dissipate it once, when it has occurred. Environmental control must be adequate. When it is dry, humidifier should be used. It is recommended to avoid using insulators that easily build static electricity. Semiconductor devices must be stored and transported in an anti-static container, static shielding bag or conductive material. All test and measurement tools including work bench and floor should be grounded. The operator should be grounded using wrist strap. Semiconductor devices must not be touched with bare hands. Similar precautions need to be taken for PW boards with semiconductor devices on it.

② HANDLING OF UNUSED INPUT PINS FOR CMOS

Note:

No connection for CMOS device inputs can be cause of malfunction. If no connection is provided to the input pins, it is possible that an internal input level may be generated due to noise, etc., hence causing malfunction. CMOS devices behave differently than Bipolar or NMOS devices. Input levels of CMOS devices must be fixed high or low by using a pull-up or pull-down circuitry. Each unused pin should be connected to V_{DD} or GND with a resistor, if it is considered to have a possibility of being an output pin. All handling related to the unused pins must be judged device by device and related specifications governing the devices.

③ STATUS BEFORE INITIALIZATION OF MOS DEVICES

Note:

Power-on does not necessarily define initial status of MOS device. Production process of MOS does not define the initial operation status of the device. Immediately after the power source is turned ON, the devices with reset function have not yet been initialized. Hence, power-on does not guarantee out-pin levels, I/O settings or contents of registers. Device is not initialized until the reset signal is received. Reset operation must be executed immediately after power-on for devices having reset function.

- **The information in this document is current as of January, 2001. The information is subject to change without notice. For actual design-in, refer to the latest publications of NEC's data sheets or data books, etc., for the most up-to-date specifications of NEC semiconductor products. Not all products and/or types are available in every country. Please check with an NEC sales representative for availability and additional information.**
 - No part of this document may be copied or reproduced in any form or by any means without prior written consent of NEC. NEC assumes no responsibility for any errors that may appear in this document.
 - NEC does not assume any liability for infringement of patents, copyrights or other intellectual property rights of third parties by or arising from the use of NEC semiconductor products listed in this document or any other liability arising from the use of such products. No license, express, implied or otherwise, is granted under any patents, copyrights or other intellectual property rights of NEC or others.
 - Descriptions of circuits, software and other related information in this document are provided for illustrative purposes in semiconductor product operation and application examples. The incorporation of these circuits, software and information in the design of customer's equipment shall be done under the full responsibility of customer. NEC assumes no responsibility for any losses incurred by customers or third parties arising from the use of these circuits, software and information.
 - While NEC endeavours to enhance the quality, reliability and safety of NEC semiconductor products, customers agree and acknowledge that the possibility of defects thereof cannot be eliminated entirely. To minimize risks of damage to property or injury (including death) to persons arising from defects in NEC semiconductor products, customers must incorporate sufficient safety measures in their design, such as redundancy, fire-containment, and anti-failure features.
 - NEC semiconductor products are classified into the following three quality grades:
"Standard", "Special" and "Specific". The "Specific" quality grade applies only to semiconductor products developed based on a customer-designated "quality assurance program" for a specific application. The recommended applications of a semiconductor product depend on its quality grade, as indicated below. Customers must check the quality grade of each semiconductor product before using it in a particular application.
"Standard": Computers, office equipment, communications equipment, test and measurement equipment, audio and visual equipment, home electronic appliances, machine tools, personal electronic equipment and industrial robots
"Special": Transportation equipment (automobiles, trains, ships, etc.), traffic control systems, anti-disaster systems, anti-crime systems, safety equipment and medical equipment (not specifically designed for life support)
"Specific": Aircraft, aerospace equipment, submersible repeaters, nuclear reactor control systems, life support systems and medical equipment for life support, etc.
- The quality grade of NEC semiconductor products is "Standard" unless otherwise expressly specified in NEC's data sheets or data books, etc. If customers wish to use NEC semiconductor products in applications not intended by NEC, they must contact an NEC sales representative in advance to determine NEC's willingness to support a given application.
- (Note)
- (1) "NEC" as used in this statement means NEC Corporation and also includes its majority-owned subsidiaries.
 - (2) "NEC semiconductor products" means any semiconductor product developed or manufactured by or for NEC (as defined above).