

Am26S10/Am26S11

Quad Bus Transceivers

DISTINCTIVE CHARACTERISTICS

- Input to bus is inverting on Am26S10
- Input to bus is non-inverting on Am26S11
- Quad high-speed open collector bus transceivers
- Driver outputs can sink 100mA at 0.8V maximum
- Bus compatible with Am2905, Am2906, Am2907
- Advanced Schottky processing
- PNP inputs to reduce input loading

GENERAL DESCRIPTION

The Am26S10 and Am26S11 are quad Bus Transceivers consisting of four high-speed bus drivers with open-collector outputs capable of sinking 100mA at 0.8 volts and four high-speed bus receivers. Each driver output is connected internally to the high-speed bus receiver in addition to being connected to the package pin. The receiver has a Schottky TTL output capable of driving ten Schottky TTL unit loads.

An active LOW enable gate controls the four drivers so that outputs of different device drivers can be connected together for party-line operation. The enable input can be conveniently driven by active LOW decoders such as the Am25LS139.

The bus output high-drive capability in the LOW state allows party-line operation with a line impedance as low as 100Ω. The line can be terminated at both ends, and still give considerable noise margin at the receiver. The receiver typical switching point is 2.0 volts.

The Am26S10 and Am26S11 feature advanced Schottky processing to minimize propagation delay. The device package also has two ground pins to improve ground current handling and allow close decoupling between V_{CC} and ground at the package. Both GND₁ and GND₂ should be tied to the ground bus external to the device package.

BLOCK DIAGRAM

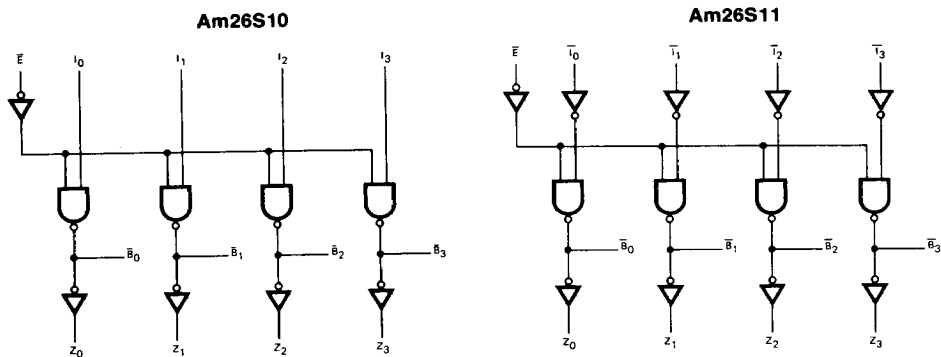

BD001770

BD001760

RELATED PRODUCTS

Part No.	Description
26S12	Quad Bus Transceiver
26S12A	Quad Bus Transceiver
2915A	Quad Three-State Bus Transceiver with Interface Logic
2916A	Quad Three-State Bus Transceiver with Interface Logic
2917A	Quad Three-State Bus Transceiver with Interface Logic

04598A

CONNECTION DIAGRAM Top View

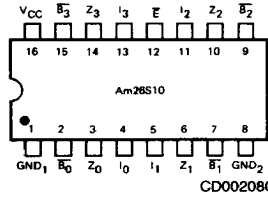

Note: Pin 1 is marked for orientation

LOGIC SYMBOL

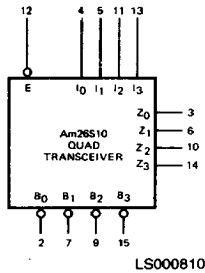

V_{CC} = Pin 16
 GND_1 = Pin 1
 GND_2 = Pin 8

METALLIZATION AND PAD LAYOUT Am26S10

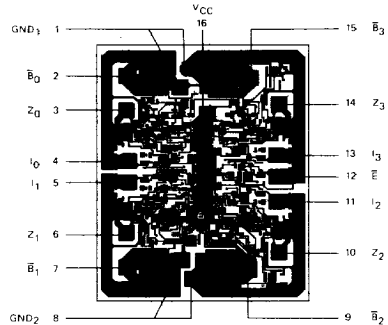

DIE SIZE 0.059" x 0.075"

ORDERING INFORMATION

AMD products are available in several packages and operating ranges. The order number is formed by a combination of the following: Device number, speed option (if applicable), package type, operating range and screening option (if desired).

Am26S10/11

D

C

B — Screening Option
 Blank — Standard processing
 B — Burn-in

— Temperature (See Operating Range)
 C — Commercial (0°C to +70°C)
 M — Military (-55°C to +125°C)

Package

D — 16-pin CERDIP
 F — 16-pin flatpak
 P — 16-pin plastic DIP
 X — Dice

Device type
 Quad Bus Transceivers

Valid Combinations

Am26S10	PC
Am26S11	DC, DM
	FM
	XC, XM

Valid Combinations

Consult the AMD sales office in your area to determine if a device is currently available in the combination you wish.

CONNECTION DIAGRAM Top View

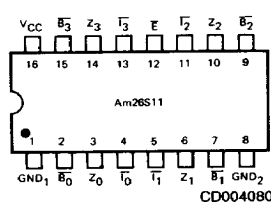

Note: Pin 1 is marked for orientation

LOGIC SYMBOL

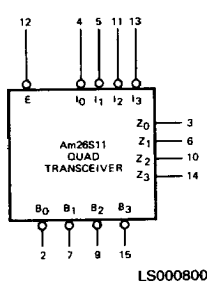

V_{CC} = Pin 16
GND₁ = Pin 1
GND₂ = Pin 8

METALLIZATION AND PAD LAYOUT

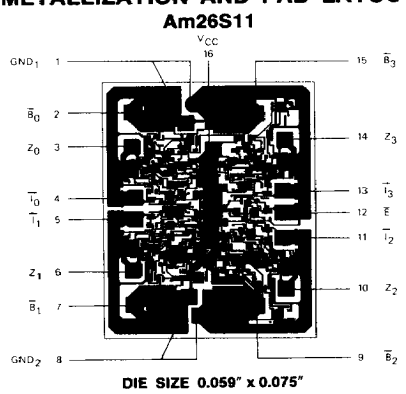

TRUTH TABLES

Am26S10

Inputs		Outputs	
\bar{E}	I	\bar{B}	Z
L	L	H	L
L	H	L	H
H	X	Y	\bar{Y}

Am26S11

Inputs		Outputs	
\bar{E}	T	\bar{B}	Z
L	L	L	H
L	H	H	L
H	X	Y	\bar{Y}

H = HIGH Voltage Level X = Don't Care L = LOW Voltage Level
 Y = Voltage Level of Bus (Assumes Control by Another Bus Transceiver)

TYPICAL APPLICATION

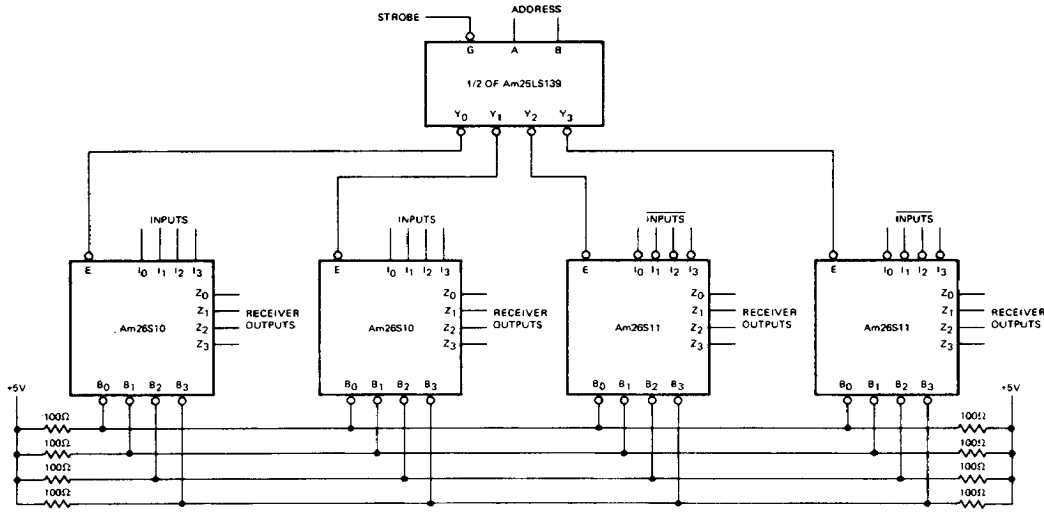

100Ω PARTY LINE OPERATION

AF001020

ABSOLUTE MAXIMUM RATINGS

Storage Temperature	-65°C to +150°C
Ambient Temperature Under Bias	-55°C to +125°C
Supply Voltage to Ground Potential	
Continuous	-0.5V to +7.0V
DC Voltage Applied to Outputs For	
High Output State	-0.5V to +V _{CC} max
DC Input Voltage	-0.5V to +5.5V
DC Output Current, Into Bus	200mA
DC Output Current, Into Outputs	
(Except Bus)	30mA
DC Input Current	-30mA to +5.0mA

Stresses above those listed under **ABSOLUTE MAXIMUM RATINGS** may cause permanent device failure. Functionality at or above these limits is not implied. Exposure to absolute maximum ratings for extended periods may affect device reliability.

OPERATING RANGES

Commercial (C) Devices	
Temperature	0°C to +70°C
Supply Voltage	+4.75V to +5.25V
Military (M) Devices	
Temperature	-55°C to +125°C
Supply Voltage	+4.5V to +5.5V

Operating ranges define those limits over which the functionality of the device is guaranteed.

DC CHARACTERISTICS over operating range unless otherwise specified

Parameters	Description	Test Conditions (Note 2)	Min	Typ (Note 1)	Max	Units	
V _{OH}	Output HIGH Voltage (Receiver Outputs)	V _{CC} = MIN, I _{OH} = -1.0mA V _{IN} = V _{IL} or V _{IH}	MIL	2.5	3.4		Volts
			COM'L	2.7	3.4		
V _{OL}	Output LOW Voltage (Receiver Outputs)	V _{CC} = MIN, I _{OL} = 20mA V _{IN} = V _{IL} or V _{IH}			0.5	Volts	
V _{IH}	Input HIGH Level (Except Bus)	Guaranteed input logical HIGH for all inputs	2.0			Volts	
V _{IL}	Input LOW Level (Except Bus)	Guaranteed input logical LOW for all inputs			0.8	Volts	
V _i	Input Clamp Voltage (Except Bus)	V _{CC} = MIN, I _{IN} = -18mA			-1.2	Volts	
I _{IL}	Input LOW Current (Except Bus)	V _{CC} = MAX, V _{IN} = 0.4V	Enable		-0.36	mA	
			Data		-0.54		
I _{IH}	Input HIGH Current (Except Bus)	V _{CC} = MAX, V _{IN} = 2.7V	Enable		20	μA	
			Data		30		
I _I	Input HIGH Current (Except Bus)	V _{CC} = MAX, V _{IN} = 5.5V			100	μA	
I _{SC}	Output Short Circuit Current (Except Bus)	V _{CC} = MAX (Note 3)	MIL	-20	-55	mA	
			COM'L	-18	-60		
I _{CC}	Power Supply Current (All Bus Outputs LOW)	V _{CC} = MAX Enable = GND	Am26S10		45	mA	
			Am26S11		80		

- Notes: 1. Typical limits are at V_{CC} = 5.0V, 25°C ambient and maximum loading.
 2. For conditions shown as MIN or MAX, use the appropriate value specified under Electrical Characteristics for the applicable device type.
 3. Not more than one output should be shorted at a time. Duration of the short circuit test should not exceed one second.

Bus Input/Output Characteristics

Parameters	Description	Test Conditions (Note 2)		Min	Typ (Note 1)	Max	Units
V _{OL}	Output LOW Voltage	V _{CC} = MIN	MIL	I _{OL} = 40mA	0.33	0.5	Volts
				I _{OL} = 70mA	0.42	0.7	
				I _{OL} = 100mA	0.51	0.8	
			COM'L	I _{OL} = 40mA	0.33	0.5	
				I _{OL} = 70mA	0.42	0.7	
				I _{OL} = 100mA	0.51	0.8	
I _O	Bus Leakage Current	V _{CC} = MAX	MIL	V _O = 0.8V		-50	μA
				V _O = 4.5V		200	
I _{OFF}	Bus Leakage Current (Power Off)	V _O = 4.5V	COM'L	V _O = 4.5V		100	μA
				V _O = 4.5V		100	
V _{TH}	Receiver Input HIGH Threshold	Bus Enable = 2.4V V _{CC} = MAX	MIL	2.4	2.0		Volts
			COM'L	2.25	2.0		
V _{TL}	Receiver Input LOW Threshold	Bus Enable = 2.4V V _{CC} = MIN	MIL		2.0	1.6	Volts
			COM'L		2.0	1.75	

- Notes: 1. Typical limits are at V_{CC} = 5.0V, 25°C ambient and maximum loading.
 2. For conditions shown as MIN or MAX, use the appropriate value specified under Electrical Characteristics for the applicable device type.
 3. Not more than one output should be shorted at a time. Duration of the short circuit test should not exceed one second.

TYPICAL PERFORMANCE CURVES

Typical Bus Output Low Voltage Versus Ambient Temperature

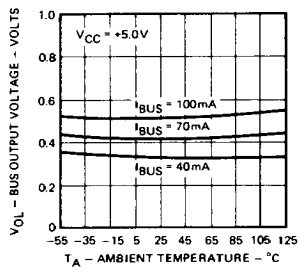

Receiver Threshold Variation Versus Ambient Temperature

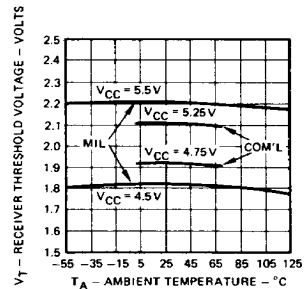

SWITCHING TEST CIRCUIT

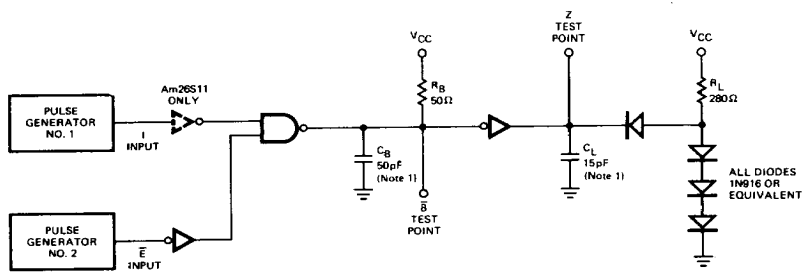

TC000900

Note 1. Includes Probe and Jig Capacitance.

SWITCHING CHARACTERISTICS (TA = +25°C, VCC = 5.0V)

Parameters	Description	Test conditions	Min	Typ	Max	Units		
tPLH	Data Input to Bus	RB = 50 Ω CB = 50 pF (Note 1)		10	15	ns		
tPHL				10	15			
tPLH			Am26S11		12		19	
tPHL					12		19	
tPLH	Enable Input to Bus		RB = 50 Ω CB = 50 pF (Note 1)		14	18	ns	
tPHL					13	18		
tPLH				Am26S10		15		20
tPHL						14		20
tPLH	Bus to Receiver Out	RB = 50 Ω, RL = 280 Ω CB = 50 pF (Note 1) CL = 15 pF			10	15	ns	
tPHL					10	15		
tr	Bus			RB = 50 Ω CB = 50 pF (Note 1)	4.0	10		ns
tf	Bus				2.0	4.0		ns

Note 1. Includes probe and jig capacitance.

WAVEFORMS

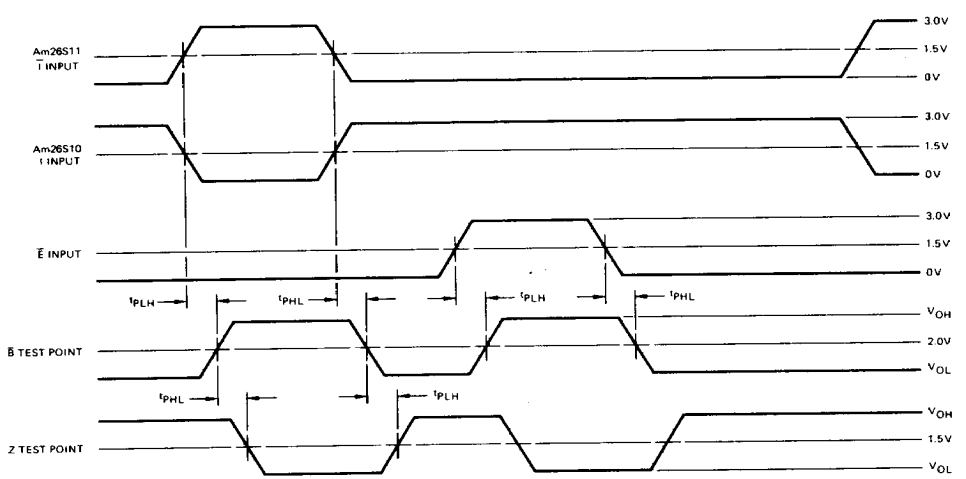

WF002290

Am26S10/Am26S11 SCHEMATIC DIAGRAM

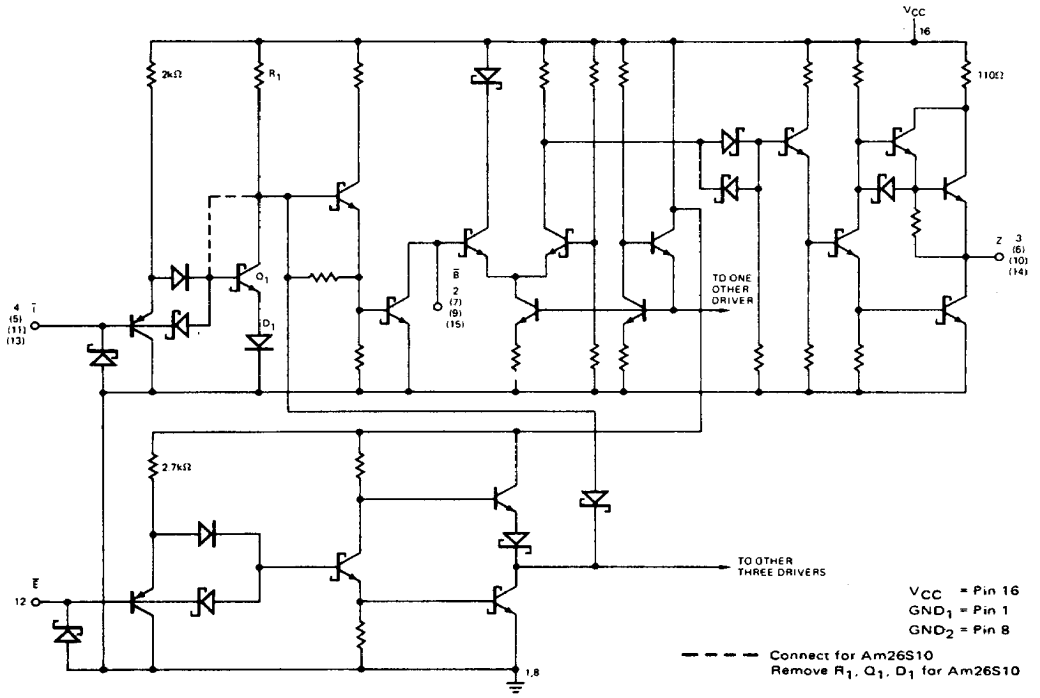

IC000400