

TA8443F

PRELIMINARY DATA

PLL-PWM 3-PHASE HALL MOTOR PRE-DRIVER

TA8443F is 3-phase hall motor pre-driver with PLL controller and PWM controller.

8 bit D/A converter system has been employed for each of the speed control system (AFC) and the phase control system (APC).

TA8443F contains two error amplifiers, adjustable oscillator, dead-time control comparator, pulse-steering flip-flop, and output-control circuit.

- This is multi-chip IC with TC9203, TA76494 and TA7712.
- Start/stop, CW/CCW and brake function are provided.
- Package is QFP-60.
- For further details, refer to each technical data.

Unit in mm

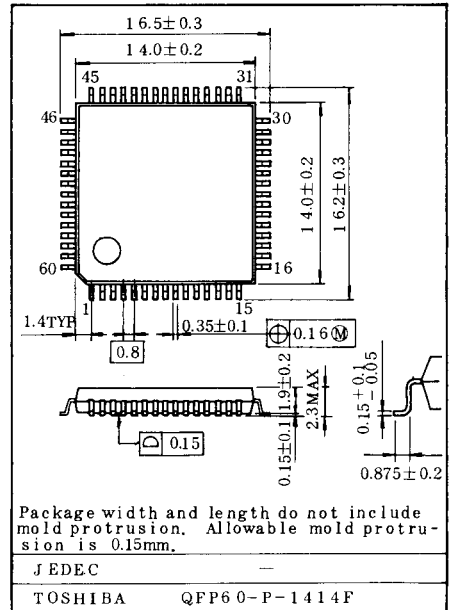

MAXIMUM RATINGS (Ta=25°C)

BLOCK	CHARACTERISTIC	SYMBOL	RATING	UNIT
PULL part (TC9203)	Supply Voltage	V _{DD}	-0.3~7.0	V
	Input Voltage	V _{IN}	-0.3~V _{DD} +0.3	V
PWM part (TA76494)	Supply Voltage	V _{CC1}	30	V
	Amplifier Input Voltage	V _{ICM}	V _{CC} +0.3	V
	Collector Output Voltage	V _{CER}	30	V
Controller part (TA7712)	Collector Output Current	I _C	250	mA
	Power Supply Voltage	V _{CC2}	8.0	V
	Output Current	I _O	±25	mA
TA8443F	Position Sensing Circuit Input Voltage (T _j =25°C)	V _H	±500	mV
	Power Dissipation	P _D	810	mW
	Operating Temperature	T _{opr}	-30~75	°C
	Storage Temperature	T _{stg}	-55~1	°C

TA8443F

BLOCK DIAGRAM

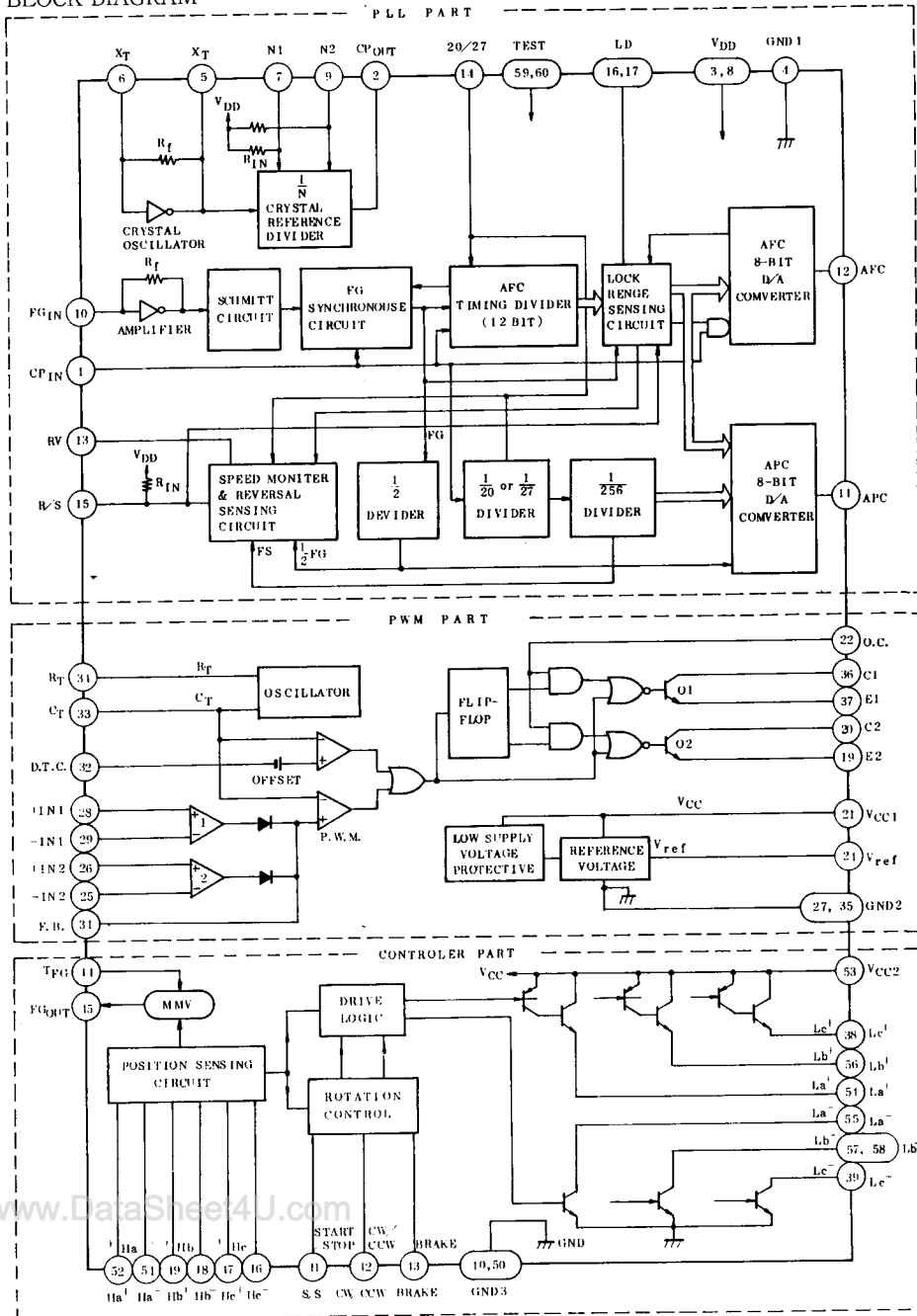

PIN CONNECTION

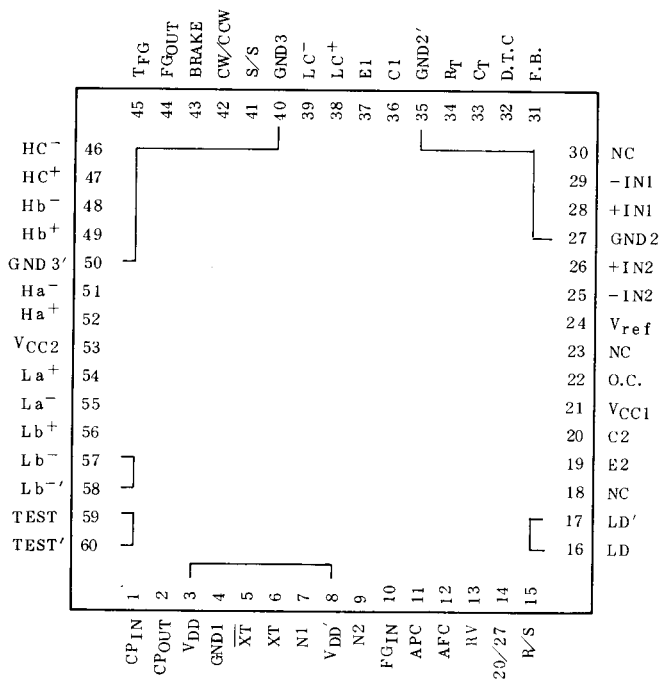

NC : No - connection
 [: inner short

POWER DISSIPATION

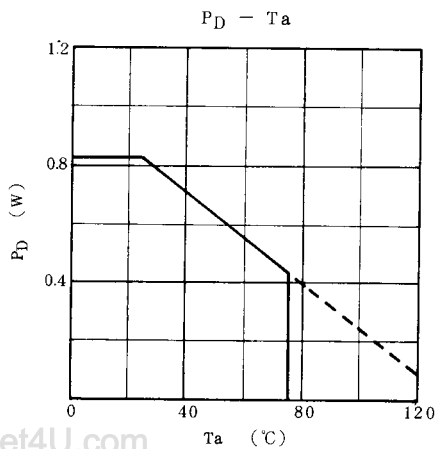

TA8443F

ELECTRICAL CHARACTERISTICS

PLL PART (Unless otherwise specified, $V_{DD}=5V$, $T_a=25^\circ C$)

CHARACTERISTIC		SYMBOL	TEST CIR-CUIT	TEST CONDITION	MIN.	TYP.	MAX.	UNIT		
Operating Supply Voltage		V_{DD}	-	*	4.5	5.0	5.5	V		
Operating Supply Current		I_{DD}	-	$X'tal=8MHz$ $CP_{IN}=CP_{OUT}$	*	-	5.0	12.0	mA	
Operating Frequency Range	X_T	f_{XT}	-	*	1.0	~	8.0	MHz		
	CP_{IN}	f_{CP}	-	Square wave	*	0.05	~		4.0	
	FG_{IN}	f_{FG}	-	$V_{IN}=0.5Vp-p$ Sine wave	*	-	~	10	kHz	
Input Operating Voltage		FG_{IN}	$V_{IN FG}$	-	$f_{FG}=10kHz$ Sine wave	*	0.5	~	$V_{DD}-0.5$	Vp-p
AFC, APC D/A Converter	Ladder Resistor	R_L	-		30	50	75	$k\Omega$		
	Max. Deviation		-	$V_{DD}=4.5\sim 5.5V$	-	± 2.5	± 6.5	LSB		
	Resolution		-		-	$V_{DD}/256$	-	V		
	Temperature Drift		-		-	± 1	-	LSB		
Pullup Resistor		R_{IN}	-	$N1, N2, 20/27, R/S$	*	10	30	50	$k\Omega$	
Input Voltage	"H" Level	V_{IH}	-	$N1, N2, 20/27, R/S$	*	$V_{DD}\times 0.8$	~	V_{DD}		
	"L" Level	V_{IL}	-	CP_{IN}	*	0	~	$V_{DD}\times 0.2$		
Input Leak Current		I_{IH}/I_{IL}	-	CP_{IN}	*	-	-	± 1.0	μA	
Output Current	"H" Level	I_{OH}	-	RV, LD		$V_{OH}=4V$	-0.5	-1.0	-	mA
	"L" Level	I_{OL}	-	CP_{OUT}		$V_{OL}=1V$	0.5	1.0	-	
Amplifier Feedback Resistor	X_T	R_f	-		100	200	400	$k\Omega$		
	FG_{IN}				300	500	800			

*: Guaranteed within the range of $V_{DD}=4.5V\sim 5.5V$, $T_a=-30\sim 75^\circ C$.

PWM PART ($V_{CC1}=15V$, $f=10kHz$ unless otherwise noted)

• REFERENCE SECTION

CHARACTERISTIC	SYMBOL	TEST CONDITIONS	MIN.	TYP.	MAX.	UNIT
Output Voltage	V_{ref}	$I_{ref}=1mA$, $T_a=25^{\circ}C$	4.75	5	5.25	V
Input Regulation	REG_{IN}	$7V \leq V_{CC1} \leq I_{ref}=1mA$, $T_a=25^{\circ}C$		8	25	mV
Output Regulation	REG_L	$1mA \leq I_{ref} \leq 10mA$, $T_a=25^{\circ}C$		1	15	mV
Output Voltage Change with Temperature	V_{ref}/T	$-30^{\circ}C \leq T_a \leq +75^{\circ}C$ $I_{ref}=1mA$		0.01	0.03	%/ $^{\circ}C$
Short-circuit Output Current Note 2	I_{short}	$V_{ref}=0$		50		mA

• OSCILLATOR SECTION

CHARACTERISTIC	SYMBOL	TEST CONDITIONS	MIN.	TYP.	MAX.	UNIT
Frequency	f_{OSC}	$C_T=0.01\mu F$, $R_T=12k$		10		kHz
Standard Deviation of Frequency Note 3		All values of V_{CC} , C_T , R_T , T_a constant		10		%
Frequency Change with Voltage		$7V \leq V_{CC1} \leq 40V$, $C_T=0.01\mu F$ $T_a=25^{\circ}C$, $R_T=12k$		1		%
Frequency Change with Temperature		$0^{\circ}C \leq T_a \leq 70^{\circ}C$, $C_T=0.01\mu F$, $R_T=12k$		1	2	%

• DEAD-TIME CONTROL SECTION

CHARACTERISTIC	SYMBOL	TEST CONDITIONS	MIN.	TYP.	MAX.	UNIT
Input Bias Current		$0 \leq V_I \leq 5.25V$		-2	-10	μA
Maximum Duty Cycle, Each Output		$V_I=0$	45	49		%
Input Threshold Voltage		Zero Duty Cycle		3	3.3	V
		Maximum Duty Cycle	0			V

• PWM COMPARATOR SECTION

CHARACTERISTIC	SYMBOL	TEST CONDITIONS	MIN.	TYP.	MAX.	UNIT
Input Threshold Voltage		Zero Duty Cycle		4	4.5	V
Input Sink Current		$V(\text{pin } 3)=0.7V$	0.3	0.7		mA

TA8443F

• ERROR-AMPLIFIER SECTION

CHARACTERISTIC		SYMBOL	TEST CONDITIONS	MIN.	TYP.	MAX.	UNIT
Input Offset Voltage		V _{IO}	V _{OAMP} =2.5V		2	10	mV
Input Offset Current		I _{IO}	V _{OAMP} =2.5V		25	250	nA
Input Bias Current			V _{OAMP} =2.5V		0.2	1	μA
Common-mode Input Voltage Ragne	Low Level	V _{ICM}	7V ≤ V _{CC1} ≤ 40V	-0.3			V
	High Level			V _{CC-2}			
Open-loop Voltage Amplification		A _v	V _{OAMP} =0.5V~3.5V, Ta=25°C	60	80		dB
Unity-gain Bandwidth			Ta=25°C	500	830		kHz
Common-mode Rejection Ratio		CMR	V _{CC1} =40V, Ta=25°C	65	80		dB
Output Sink Current			V _{OAMP} =0.7V	0.3	0.7		mA
Output Source Current			V _{OAMP} =3.5V	-2	-10		mA

• OUTPUT SECTION

CHARACTERISTIC		SYMBOL	TEST CONDITIONS	MIN.	TYP.	MAX.	UNIT
Collector Off-state Current		I _{CER}	V _{CE} =40V, V _{CC} =40V			100	A
Emitter Off-state Current			V _{CC1} =V _C =40V, V _E =40V			-100	A
Collector-emitter Saturation Voltage	Common-emitter	V _{CE(sat)}	I _C =200mA, V _E =0V		0.95	1.3	V
	Emitter follower	V _{CE(ON)}	I _E =-200mA, V _C =15V		1.6	2.5	V
Output Voltage Rise Time		t _{r1}	V _{CC1} =15V, R _L =150, Ta=25°C		100	200	ns
Output Voltage Fall Time		t _{f1}	I _C ≠100mA, Common-emitter		70	200	ns
Output Voltage Rise Time		t _{r2}	V _{CC1} =15V, R _L =150, Ta=25°C		100	200	ns
Output Voltage Fall Time		t _{f2}	I _E ≠100mA, Common-follower		70	200	ns

• SUPPLY CURRENT

CHARACTERISTIC	SYMBOL	TEST CONDITIONS	MIN.	TYP.	MAX.	UNIT
Standby Supply Current	I _{CC(SB)}	V _{CC1} =15V, All other inputs and outputs open		8	12.5	mA
Average Supply Current	I _{CC(BI)}	V _(pin 4) =2V		10		mA

Note 1: All typical values except for temperature coefficients are at Ta=25°C.

Note 2: Duration of the short-circuit should not exceed one second.

Note 3: Standard deviation is a measure of the statistical distribution about the mean as derived from the formula.

$$\sigma = \sqrt{\frac{\sum_{n=1}^N (X_n - \bar{X})^2}{N - 1}}$$

www.DataSheet4U.com

CONTROLLER PART (Unless otherwise specified, $V_{CC2}=5V$, $T_a=25^\circ C$)

CHARACTERISTIC		SYMBOL	TEST CIR-CUIT	TEST CONDITION	MIN.	TYP.	MAX.	UNIT			
Operation Power Supply Voltage		V_{CC2} opr	-		4.75	5.00	5.25	V			
Power Supply Current		I_{CC1}	-	Stop State	-	3.4	6.0	mA			
		I_{CC2}	-	Output Open	-	17.0	26.0				
Saturation Voltage	Upper Side	V_{SAT} U-1	-	$R_L=200\Omega$	-	1.3	2.0	V			
		V_{SAT} U-2		$R_L=2k\Omega$	-	1.0	1.3				
	Lower Side	V_{SAT} L-1		$R_L=200\Omega$	-	0.8	1.2				
		V_{SAT} L-2		$R_L=2k\Omega$	-	0.18	0.4				
Leak Current	Upper Side	I_L U	-		-	-	100	μA			
	Lower Side	I_L L	-		-	-	100				
Position Sensing Input	Common Mode Voltage Range		CMR H	-			2.0	-	4.5	V	
	Input Sensitivity		V_H	-			20	-	-	mV	
	Input Hysteresis		V_H -Hye	-			2	7	15		
START Input. (RUN)	Operation	"H"	V_{IN} R(H)	-			4.0	-	-	V	
	Input Voltage	"L"	V_{IN} R(L)	-			-	-	1.0		
	Input Current	"L"	I_{IN} R	-	V_{IN} R=1.0V			-	-	200	μA
CW/CCW Input (FWD/REV)	Operation	"H"	V_{IN} C(H)	-			4.0	-	-	V	
	Input Voltage	"L"	V_{IN} C(L)	-			-	-	1.0		
	Input Current	"L"	I_{IN} C	-	V_{IN} C=1.0V			-	-	200	μA
BRAKE Input (BRAKE)	Operation	"H"	V_{IN} B(H)	-			4.0	-	-	V	
	Input Voltage	"L"	V_{IN} B(L)	-			-	-	1.0		
	Input Current	"L"	I_{IN} B	-	V_{IN} N=1.0V			-	-	200	μA
FG Output	Output Current	"H"	I_{FGH}	-			80	-	-	μA	
	Output Voltage	"L"	V_{FGL}	-	$I_{FG}=0.3mA$			-	-	0.4	V
	Pulse Width		τ_{FG}	-	$C=0.1\mu F$, $R=10k\Omega$			0.9	1.0	1.1	ms

PLL PART OPERATION

1. Crystal oscillation terminals (XT, XT)

- The crystal oscillator is used by connecting as shown below.

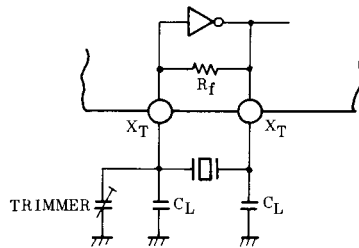

- C_L of 10~30pF is appropriate.

- Crystal oscillation frequency is calculated by the following equation according to number of FG pulses of a motor to be used.

$$f_X = \frac{R}{60} \times FG' \times 128 \times (20 \text{ or } 27) \times N \quad (\text{Hz})$$

(Note) (20 or 27): 20 at 20/27="H" or Open.
27 at 20/27="L".

f_X : Crystal oscillation frequency, FG' : number of FG pulse generated per revolution of motor, R : revolution of motor per minute, N : Ratio of frequency division of the crystal reference frequency divider.

(Refer to Item 9.)

- Maximum operating frequency is above 8MHz and crystals up to 8MHz can be used.

2. Reference frequency input/output terminals (CPIN, CPOUT)

- Divided output $\frac{f_X}{N}$ from the crystal reference frequency divider is available at CPOUT, which is normally connected CPIN.
- When an external oscillator (CR oscillator, etc.) is connected to CPIN, motor speed can be finally adjusted.

3. FG pulse input terminal (FG_{IN})

- This is the input terminal of FG pulse that shows the motor speed. This FG pulse becomes comparison frequency.
- This terminal has built-in Amplifier and Schmitt circuit. FG pulses are applied through capacitor coupling and small amplitude is enough for proper operation.

4. Lock range switching terminal (20/27)

- This terminal is for switching lock range of motor, with a pull-up resistor and chattering preventive circuit.

(TRUTH TABLE)

20/27	DIVIDED FREQUENCY	LOCK RANGE
L	1/27	+3.4~-3.9% of reference cycle
H or NC	1/20	+4.6~-5.3% of reference cycle

5. APC, AFC output terminal (APC, AFC)

- AFC (speed control output) is a F-V converter for FG frequency, and is consisting of a 8 bit D/A converter.
- APC (phase control output) is a phase comparator (ϕ -V converter) that compares phase difference ϕ between 1/2 FG and reference frequency FS' , and is also consisting of a 8 bit D/A converter.
- Both APC and AFC perform the following 3 operations according to FG_{IN} frequency.
 - When FG_{IN} frequency is within the lock range:
Both APC and AFC perform the normal operation for FG_{IN} .
 - When FG_{IN} frequency is below the lock range (under speed):
APC and AFC outputs are both fixed at "H" level.
 - When FG_{IN} frequency is above the lock range (over speed):
APC and AFC outputs are both fixed at "L" level.
- When a motor is in STOP state (P/S=H or NC), both AFC and APC are fixed "L" level.

TA8443F

AFC Output change status for FG_{IN} frequency

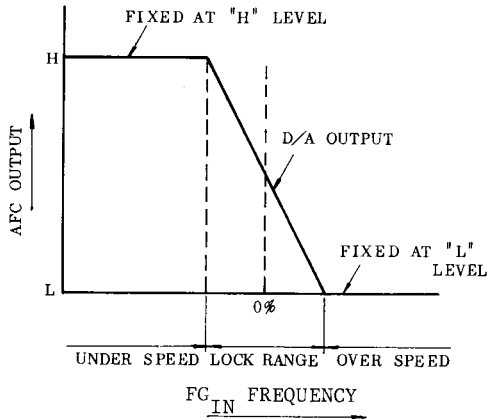

APC Output change status for phase difference ϕ

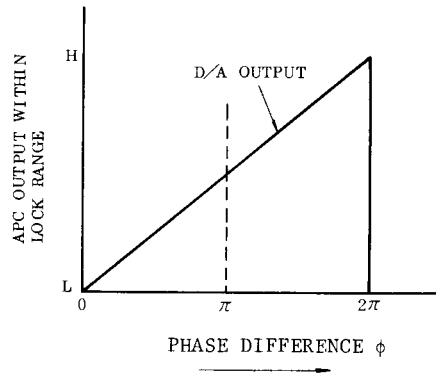

• AFC and APC timing chart within lock range.

a. AFC (SPEED CONTROL SYSTEM)

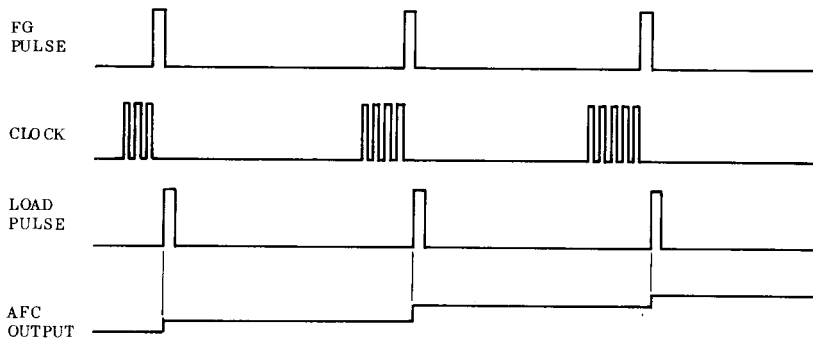

b. APC (PHASE CONTROL SYSTEM)

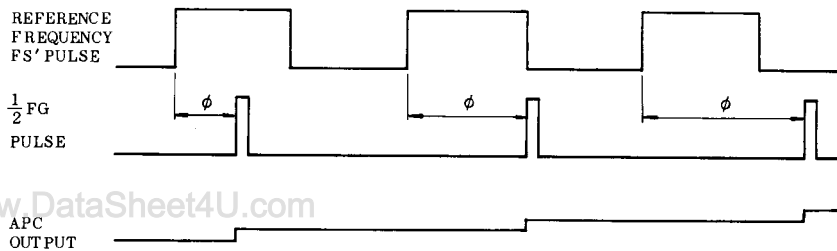

www.DataSheet4U.com

6. Lock detecting terminal (LD)

- This terminal is the lock detecting output and is placed at "H" level when FG_{IN} frequency is within the lock range and otherwise, placed at "L" level.

7. RUN/STOP input terminal (R/S)

- RUN/STOP signals of the motor are input to this terminal.
- This terminal has a pull-up resistor and a chattering preventive circuit.
- During RUN ($R/S=L$), AFC, APC and LD perform the above-mentioned operations for FG_{IN} frequency, and during STOP ($R/S=H$ or NC), AFC, APC and LD are all fixed at "L" level.

8. Reverse signal output terminal (RV)

- At the switching of lock range from 1/20 to 1/27 or the operating from RUN to STOP, reverse signal for braking the motor is output through this terminal.
- Change of RV output status

PREVIOUS STATUS	RV OUTPUT CHANGE TO "H" LEVEL	RV OUTPUT CHANGE TO "L" LEVEL
During normal rotation (during lock) at 1/20.	When the lock range is switched from 1/20 to 1/27.	When the motor speed is locked at 1/27, or when FG_{IN} 1/8FS, or when the lock range is switched from 1/27 to 1/20.
During normal rotation (during lock) at 1/20 or 1/27.	When the operation is switched from RUN to STOP.	When FG_{IN} 1/8FS or when the operation is switched from STOP to RUN.

- In other cases than above, RV output is not changed and fixed at "L" level.
- Further, if FG frequency rises up to 1.5 times of normal rotation at 1/20 (2 times of normal rotation at 1/27), RV output is reset.

www.DataSheet4U.com

TA8443F

9. Reference divided frequency switching terminal (N1, N2)

- Divided frequency 1/N of the crystal reference frequency divider can be switched to 1/5, 1/6 or 1/12 by number of FG pulses or a crystal used.
- This terminal has a built-in pull-up resistor.

(TRUTH TABLE)

N1	N2	1/N
H	H	1/5
L	H	1/6
H	L	1/12

1/N: CRYSTAL REFERENCE DIVIDED FREQUENCY

(Note) Don't use mode, N1=N2="L", because this mode is test mode.

CAUTION IN APPLICATION

- APC and AFC terminals are for the 8-bit D/A converter outputs, which are directly output from the R-2R ladder type resistor network as shown in the following diagram. Impedance of these outputs becomes equal to the ladder resistor value R_L . Therefore, input impedance at the receiving side of these terminals shall be designed accordingly.

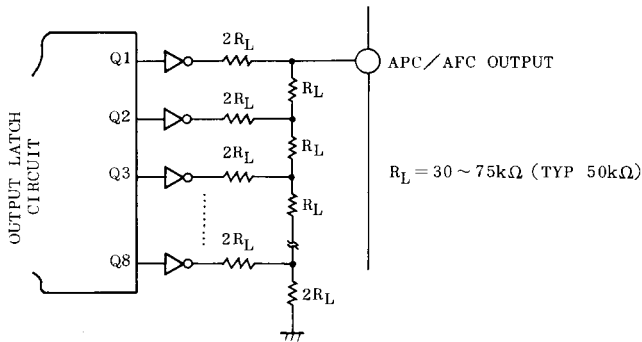

- A filter for an externally mounted differential amplifier on an application circuit shall be selected to meet the response characteristic of a motor to be used.

www.DataSheet4U.com

PWM PART OPERATION

The uncommitted output transistors provide either common-emitter or emitter-follower output capability.

Push-pull or single-ended output operation may be selected through the output-control function.

The architecture of the TA8443F prohibits the possibility of either output being pulsed twice during push-pull operation.

VOLTAGE WAVEFORMS

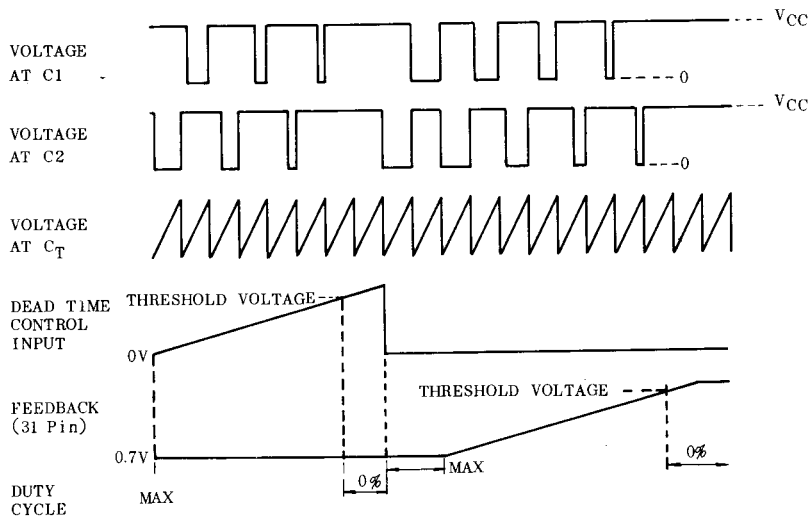

TA8443F

CONTROLLER PART OPERATION

1. TIMING CHART

FORWARD ROTATION (Position sensing signal advances Ha → Hb → Hc.)

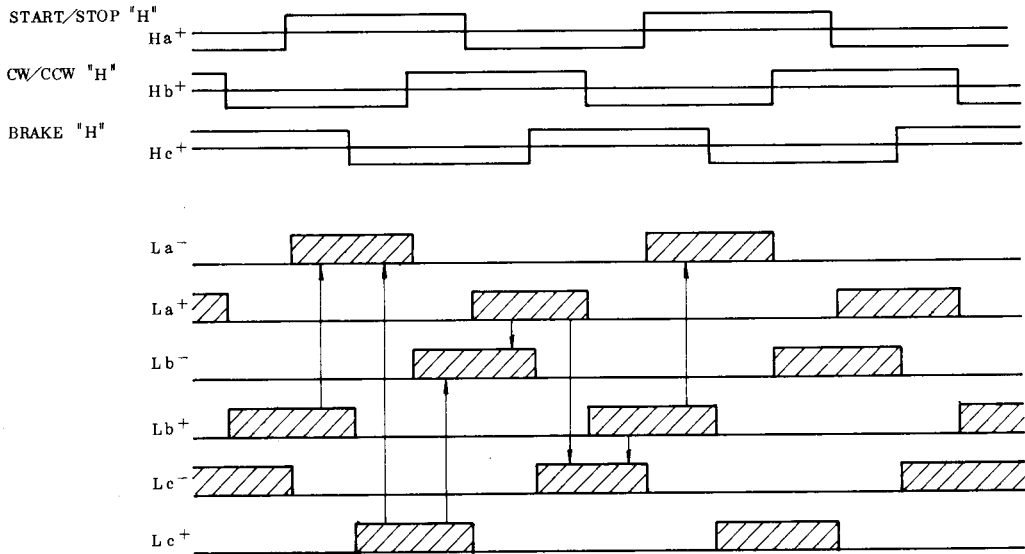

REVERSE ROTATION (Position sensing signal advances Ha → Hc → Hb.)

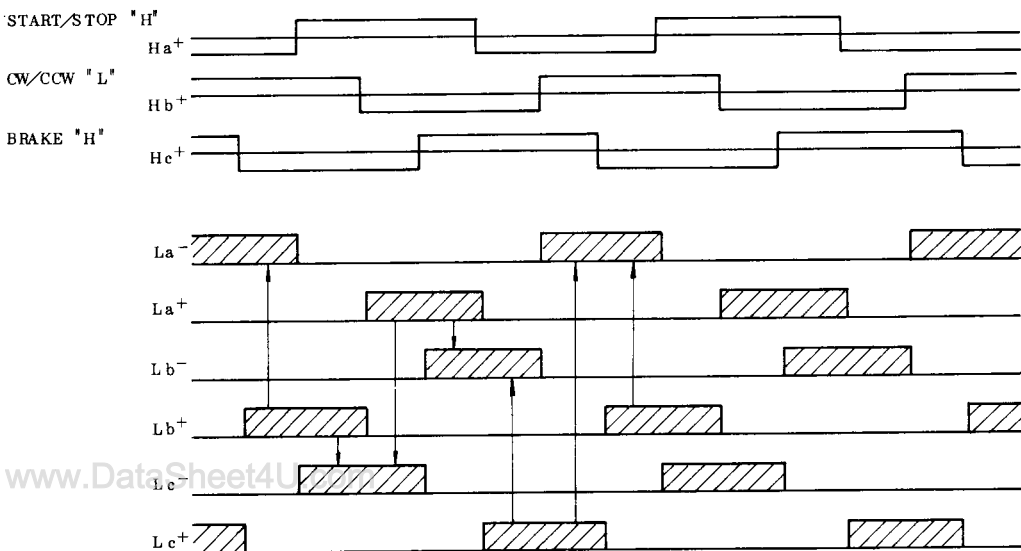

2. APPLICATION OF CONTROLLER PART

Like a video disk player, TA8443P is provided with the stopping function which in a short time, stops the motor having a large inertia, and makes the quick disk-change possible. To make the frequency generator (FG) unnecessary which was formerly required for fetching the rotation signal, the signal from the position sensing input is ORed and is output to FG output pin (44 pin). Therefore, for FG output, three position sensing outputs (Ha, Hb, Hc) are ORed, and the rotation speed signal of the frequency of six times that of one output can be fetched resulting in making it possible to obtain a sufficient controlling characteristic with the F/V (Frequency-Voltage) conversion method of mono-stable type.

(1) Operation of FG Output (44 pin) and T_{FG} (45 pin)

In Fig. 1, Q1 and Q3 are the mono-stable multivibrator to which gate (Q2 base) the signal from each position sensing input of Ha, Hb and Hc is input after ORed and shaped in waveform by FE. The pulse width of MMV made by Q1 and Q2 is determined by R2 and C2 to be connected to T_{FG} (45 pin), and the square wave having the pulse width to be determined by C2 and R2 is output. Of course, this frequency is proportional to the rotation signal and this frequency is six times the frequency of each position sensing. (6 per 1 electrical rotation) F/V conversion operation is made through connecting FG₀ output to LPF for integration. However, if R2 is made variable, the conversion gain can be controlled.

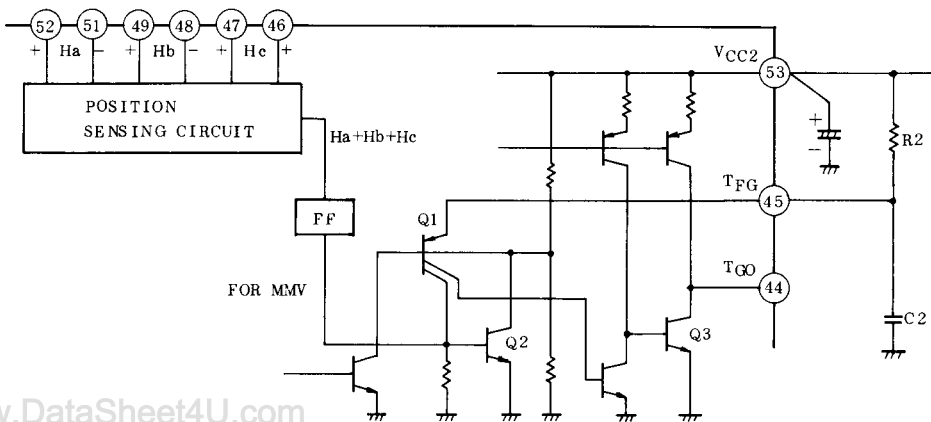

Fig. 1

TA8443F

(2) Each Control Input

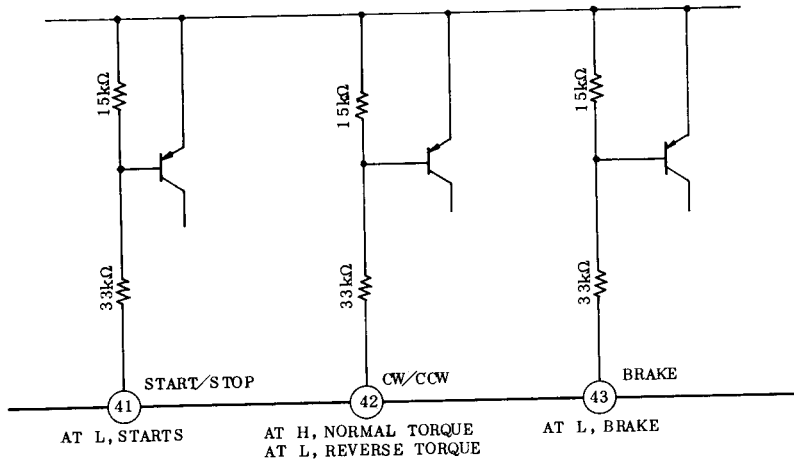

Fig. 2

START/STOP	CW/CCW	BRAKE	OUTPUT
H	H	H	Normal torque mode
H	L	H	Reverse torque mode
H/L	H/L	L	BRAKE mode
L	H/L	H	STOP mode

Note: In STOP mode, (38), (39), (54), (55), (56) and (57) pins of output are all made OFF. In BRAKE mode, (39), (55) and (57) pins of output are made ON. (sweep-out mode)

(3) Output Circuit

As shown in the block diagram, in the output circuit, the Darlington emitters of PNP and NPN are provided on the upper side, and the lower side is made as the open collector of NPN.

Connect the external transistor in the same manner as that of the application circuit.

www.DataSheet4U.com

CHARACTERISTIC DATA OF PLL PART

