

HITACHI

KAOHSIUNG HITACHI
ELECTRONICS CO.,LTD
P.O. BOX 26-27
2,13TH EAST ST.K.E.P.Z.
KAOHSIUNG TAIWAN R.O.C.
TEL:(07) 8211101(10 LINE)
TELEX:81903 KHE
FAX:(07) 821-5860

FOR MESSRS. : _____

DATE : FEB.10.'98

CUSTOMER'S ACCEPTANCE SPECIFICATIONS

LMG7520RPFC

CONTENTS

No.	ITEM	SHEET No.	PAGE
1	COVER	7B64PS 2701-LMG7520RPFC-4	1-1/1
2	RECORD OF REVISION	7B64PS 2702-LMG7520RPFC-4	2-1/2~2/2
3	MECHANICAL DATA	7B64PS 2703-LMG7520RPFC-4	3-1/1
4	ABSOLUTE MAXIMUM RATINGS	7B64PS 2704-LMG7520RPFC-4	4-1/1
5	ELECTRICAL CHARACTERISTICS	7B64PS 2705-LMG7520RPFC-4	5-1/2~2/2
6	OPTICAL CHARACTERISTICS	7B64PS 2706-LMG7520RPFC-4	6-1/2~2/2
7	BLOCK DIAGRAM	7B64PS 2707-LMG7520RPFC-4	7-1/1
8	INTERFACE TIMING CHART	7B64PS 2708-LMG7520RPFC-4	8-1/3~3/3
9	DIMENSIONAL OUTLINE	7B63PS 2709-LMG7520RPFC-4	9-1/3
		7B64PS 2709-LMG7520RPFC-4	9-2/3~3/3
10	APPEARANCE STANDARD	7B64PS 2710-LMG7520RPFC-4	10-1/3~3/3
11	PRECAUTION IN DESIGN	7B64PS 2711-LMG7520RPFC-4	11-1/4~4/4
12	DESIGNATION OF LOT MARK	7B64PS 2712-LMG7520RPFC-4	12-1/1
13	PRECAUTION FOR USE	7B64PS 2713-LMG7520RPFC-4	13-1/1

※WHEN PRODUCT WILL BE DISCONTINUED, CUSTOMER WILL BE INFORMED BY HITACHI WITH TWELVE MONTHS PRIOR ANNOUNCEMENT.

ACCEPTED BY: _____

PROPOSED BY: 

KAOHSIUNG HITACHI
ELECTRONICS CO.,LTD.

Sh.
No.

7B64PS 2701-LMG7520RPFC-4

PAGE 1-1/1

84010

RECORD OF REVISION

DATE	SHEET No.	SUMMARY
FEB,07,'96	7B64PS 2703 LMG7520RPFC-2 PAGE 3-1/1	(11) WEIGHT (200g) → 110g
	7B64PS 2704- LMG7520RPFC-2 PAGE 4-1/1	POWER SUPPLY FOR LC DRIVE VDD-V0 → VDD-VEE
	7B64PS 2705- LMG7520RPFC-2 PAGE 5-1/2	POWER SUPPLY CURRENT FOR LOGIC (6.0) → 8.0 mA POWER SUPPLY CURRENT FOR LC DRIVING (5.0) → 6.0 mA RECOMMENDED LC DRIVING VOLTAGE TYP TYP Ta=10°C (23.1) → Ta= 0°C 24.1 Ta=25°C (22.7) → Ta=25°C 23.0 Ta=40°C (22.0) → Ta=40°C 21.6 FRAME FREQUENCY TYP. MAX TYP. MAX 75 80 → - (140) POWER SUPPLY FOR CFL DELETE NOTE 4 ADDED
	7B64PS 2705- LMG7520RPFC-2 PAGE 5-2/2	NOTE 1 ~ NOTE 4 ADDED
	7B64PS 2706- LMG7520RPFC-2 PAGE 6-1/2	6.1 OPTICAL CHARACTERISTICS CONTRAST RATIO CONTRAST RATIO K=(12)→(20) RESPONSE TIME (RISE) tf→tr RESPONSE TIME (FALL) tr→tf
7B64PS 2706- LMG7520RPFC-2 PAGE 6-2/2	MIN (TYP) BRIGHTNESS (40.0) (60.0) ↓ 80.0 (100.0) CFL INITIAL VDD-V0=22.7V→VDD-VEE=23.0V	
7B64PS 2709- LMG7520RPFC-2 PAGE 9-1/3	ALL PAGE TOLERANCE ADDED IF1:53261-1590 → 52103-1217	

RECORD OF REVISION

DATE	SHEET No.	SUMMARY
	7B64PS 2709- LMG7520RPFC-2 PAGE 9-3/3	CFL BACKLIGHT APPEARANCE SPECIFICATION DELETED
	7B64PS 2710- LMG7520RPFC-2 PAGE 10-3/3	INTERNAL PIN CONNECTION CHANGED
MAY.13,'96	7B64PS 2706- LMG7520RPFC-3 PAGE 6-1/2	6.1 OPTICAL CHARACTERISTICS RESPONSE TIME MODIFIED tr 250ms → 160ms tf 350ms → 110ms
	7B64PS 2708- LMG7520RPFC-3 PAGE 8-1/3	8.1 TIMING CHART LOAD FREQUENCY CHANGED 52.1μs≤T≤59.5μs ↓ 29.8μs≤T≤59.5μs
	7B64PS 2708- LMG7520RPFC-3 PAGE 8-3/3	8.4 POWER SUPPLY FOR LCM AL CAPACTITOR ADDED (BETWEEN VEE AND VSS)
	7B63PS 2709- LMG7520RPFC-3 PAGE 9-1/3	9.1 DIMENSIONAL OUTLINE MOUNTING HOLD MEASUREMENT ADDED
	7B63PS 2709- LMG7520RPFC-3 PAGE 9-3/3	9.3 INTERNAL PIN CONNECTION SUITABLE FPC PITCH MODIFIED
	7B64PS 2710- LMG7520RPFC-3 PAGE 10-3/3	10.2 APPEARANCE SPECIFICATION STAINS,FOREING MATERIALS DRAK,SPOT SPEC. MODIFIED SYMBOL OF PINHOLE DEFINITION MODIFIED
FEB.10.'98	7B64PS 2708- LMG7520RPFC-4 PAGE 8-1/3	8.1 TIMING CHART FEAME SET UP TIME 1.4μs min DELETED.
	7B64PS 2712- LMG7520RPFC-4 PAGE 12-113	LOCATION OF LOT MARK CHANGED

3. MECHANICAL DATA

(1) PART NAME	LMG7520RPFC
(2) MODULE SIZE	129.6(W)mm*92.6(H)mm*7.5(D)mm
(3) EFFECTIVE DISPLAY AREA	100.0 min * 75.5 min.
(4) DOT SIZE	0.285(W)mm*0.285(H)mm
(5) DOT PITCH	0.3 (W)mm * 0.3 (H)mm
(6) NUMBER OF DOTS	320 (W) * 240 (H)DOTS
(7) DUTY	1/240
(8) LCD	FILM TYPE BLACK/WHITE (NEGATIVE TYPE) THE UPPER POLARIZER IS GLARE TYPE (HARDNESS:3H) THE BOTTOM POLARIZER IS TRANSMISSIVE TYPE.
(9) VIEWING DIRECTION	6 O'CLOCK
(10) BACK LIGHT	COLD CATHODE FLUORESCENT LAMP
(11) WEIGHT	110g

4. ABSOLUTE MAXIMUM RATINGS

4.1 ELECTRICAL ABSOLUTE MAXIMUM RATINGS. VSS=0V:STANDARD

ITEM	SYMBOL	MIN.	MAX.	UNIT	COMMENT
POWER SUPPLY FOR LOGIC	VDD-VSS	0	6.5	V	
POWER SUPPLY FOR LC DRIVE	VDD-VEE	0	27.5	V	
INPUT VOLTAGE	V_i	-0.3	VDD+0.3	V	NOTE 1
INPUT CURRENT	I_i	0	1	A	
STATIC ELECTRICITY	-	-	100	-	NOTE 2

NOTE 1 : $\overline{\text{DISP.OFF}}$,FRAME,LOAD,CP,D0~D3.

NOTE 2 :.MAKE CERTAINS YOU ARE GROUNDED WHEN HANDLING LCM.

4.2 ENVIRONMENTAL ABSOLUTE MAXIMUM RATINGS.

I T E M	OPERATING		STORAGE		COMMENT
	MIN.	MAX.	MIN.	MAX.	
AMBIENT TEMPERATURE	0°C NOTE6	40°C	-20°C	60°C	NOTE 2,3
HUMIDITY	NOTE 1		NOTE 1		WITHOUT CONDENSATION
VIBRATION	-	2.45m/s ² (0.25G)	-	11.76m/s ² (1.2G) NOTE 5	NOTE 4
SHOCK	-	29.4m/s ² (3G)	-	490.0m/s ² (50G)	XYZ DIRECTIONS NOTE 5
CORROSIVE GAS	NOT ACCEPTABLE		NOT ACCEPTABLE		

NOTE 1 : $T_a \leq 40^\circ\text{C}$:85%RH max.

$T_a > 40^\circ\text{C}$:ABSOLUTE HUMIDITY MUST BE LOWER THAN THE HUMIDITY OF 85%RH AT 40°C.

NOTE 2 : T_a AT -20°C ----- < 48HRS,AT 60°C -----< 168HRS.

NOTE 3 :BACKGROUND COLOR CHANGES SLIGHTLY DEPENDING ON AMBIENT TEMPERATURE. THIS PHENOMENON IS REVERSIBLE.

NOTE 4 :5Hz~100Hz (EXCEPT RESONANCE FREQUENCY)

NOTE 5 :THIS MODULE SHOULD BE OPERATED NORMALLY AFTER FINISH THE TEST.

NOTE 6 :HIGHER STARTING VOLTAGE OF CFL AND HEIGHER LCD DRIVING VOLTAGE ARE NEEDED WHILE OPERATING AT 0°C. THE LIFE TIME OF CFL WILL BE REDUCED WHILE OPERATING AT 0°C. NEED TO MAKE SURE OF VALUE OF I_L AND CHARACTERISTICS OF INVERTER. ALSO THE RESPONSE TIME AT 0°C WILL BE SLOWER.

5.2 ELECTRICAL CHARACTERISTICS OF BACKLIGHT

I T E M	SYMBOL	MIN.	TYP.	MAX.	UNIT	UNIT
LAMP VOLTAGE	VL	-	300	-	V	Ta=25°C
FREQUENCY	fL	-	70	85	KHz	Ta=25°C
LAMP CURRENT	IL	4	5	6	mA	Ta=25°C
STARTING DISCHARGE VOLTAGE	VS NOTE 2	(1000)	-	-	V	Ta=25°C

NOTE 1 :PLEASE CERTAINLY INFORM HITACHI BEFORE DESIGNING LAMP DRIVE CIRCUIT ACCORDING TO THE ABOVE SPECIFICATIONS.

NOTE 2 :STARTING DISCHARGE VOLTAGE IS INCREASED WHEN LCM IS OPERATING AT LOWER TEMPERATURE.
PLEASE CHECK THE CHARACTERISTICS OF INVERTER BEFORE APPLYING TO YOUR SET.

NOTE 3 :AVERAGE LIFE TIME OF CFL WILL BE DECREASED WHEN LCM IS OPERATING AT LOWER TEMPERATURE.

NOTE 4 :UNDER LOWER DRIVING FREQUENCY OF THE INVERTER, A CERTAIN BACKLIGHT (FROM CFL & CFL REELECTION SHEET) MAY GENERATE SOUND NOISE. BEFORE DESIGNING THE INVERTER, PLEASE CONSIDER DRIVING FREQUENCY AND CHECK SOUND NOISE FROM THE BACKLIGHT SYSTEM

5. ELECTRICAL CHARACTERISTICS

5.1 ELECTRICAL CHARACTERISTICS

I T E M	SYMBOL	CONDITION	MIN.	TYP.	MAX.	UNIT
POWER SUPPLY VOLTAGE FOR LOGIC	VDD-VSS	-	3.0	5.0	5.25	V
POWER SUPPLY VOLTAGE FOR LC DRIVING	VEE-VSS	-	-	-22.0	-	V
INPUT VOLTAGE NOTE 1	VI	H LEVEL	0.8VDD	-	VDD	V
		L LEVEL	0	-	0.2VDD	V
POWER SUPPLY CURRENT FOR LOGIC NOTE 2	IDD	VDD-VSS=5.0V VEE-VSS=-22.0V	-	8.0	-	mA
POWER SUPPLY CURRENT FOR LC DRIVING NOTE 2	IEE	VDD-VSS=5.0V VEE-VSS=-22.0V	-	6.0	-	mA
RECOMMENDED LC DRIVING VOLTAGE NOTE 3	VDD-VEE	Ta= 0°C , φ=10°	-	24.1	-	V
		Ta= 25°C , φ=10°	-	23.0	-	V
		Ta=40°C , φ=10°	-	21.6	-	V
FRAME FREQUENCY NOTE4	fFRAME	-	70	-	(140)	Hz

NOTE 1 :DISP.OFF,FRAME,LOAD,CP,D0~D3.

NOTE 2 :fFRAME=75Hz,D0~UD3=0,1,0,1,...
VDD-VEE=23.0V,Ta=25°C

NOTE 3 :RECOMMENDED LC DRIVING VOLTAGE FLUCTUATE ABOUT ±1.0V BY EACH MODULE.
TEST PATTERN IS ALL "Q" .

NOTE 4 :NEED TO MAKE SURE OF FLICKING AND RIPPLING OF DISPLAY WHEN SETTING THE FRAME FREQUENCY IN YOUR SET.

6. OPTICAL CHARACTERISTICS

6.1 OPTICAL CHARACTERISTICS

Ta=25°C (BACKLIGHT ON)

ITEM	SYMBOL	CONDITION	MIN.	TYP.	MAX.	UNIT	NOTE
VIEWING ANGLE	$\phi 2-\phi 1$	$K \geq 2.0$	-	40	-	deg	1,2
CONTRAST RATIO	K	$\phi = 10^\circ \theta = 0^\circ$	-	(20)	-	-	3
RESPONSE TIME (RISE)	tr	$\phi = 10^\circ \theta = 0^\circ$	-	160	-	ms	4
RESPONSE TIME (FALL)	tf	$\phi = 10^\circ \theta = 0^\circ$	-	110	-	ms	4

(MEASURE CONDITION BY HITACHI)

NOTE 1. DEFINITION OF θ AND ϕ

NOTE 3. DEFINITION OF CONTRAST "K"

$$K = \frac{\text{BRIGHTNESS ON SELECTED DOT (B1)}}{\text{BRIGHTNESS ON NON-SELECTED DOT (B2)}}$$

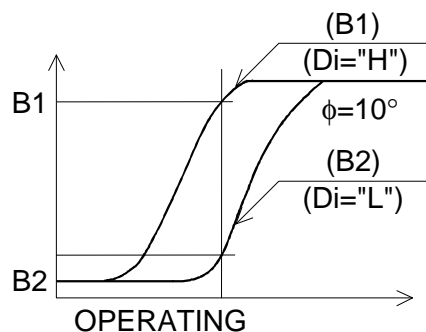
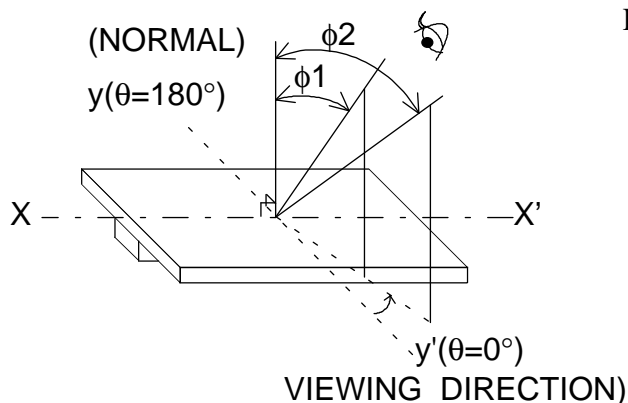

NOTE 2. DEFINITION OF VIEWING ANGLE $\phi 1$ AND $\phi 2$

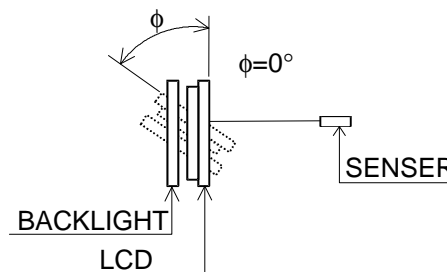
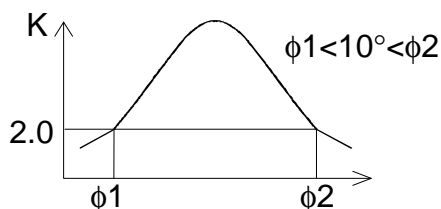

NOTE 4. DEFINITION OF OPTICAL RESPONSE

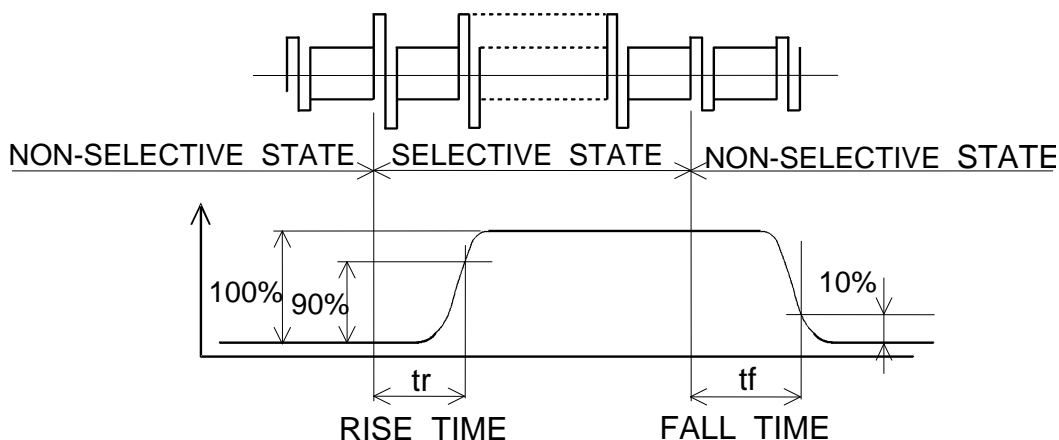

6.2 OPTICAL CHARACTERISTICS OF BACKLIGHT

(LCM, BACKLIGHT ON, $T_a=25^{\circ}\text{C}$)

ITEM	MIN.	TYP.	MAX.	UNIT	NOTE
BRIGHTNESS	80.0	(100.0)	-	cd/m ²	IL=5mA NOTE 1,2
RISE TIME	-	5	-	MINUTE	IL=5mA BRIGHTNESS 80%
BRIGHTNESS UNIFORMITY	-	-	+/-30	%	UNDERMENTIONED NOTE 1,3

CFL : INITIAL , $T_a=25^{\circ}\text{C}$, $V_{DD}-V_{EE}=23.0\text{V}$
 DISPLAY DATA SHOULD BE ALL "ON" .

NOTE 1 MEASUREMENT AFTER 10 MINUTES OF CFL OPERATING.

NOTE 2 BRIGHTNESS CONTROL :100%

NOTE 3 MEASUREMENT OF THE FOLLOWING 9 PLACES ON THE DISPLAY.
 DEFINITION OF THE BRIGHTNESS TOLERANCE.

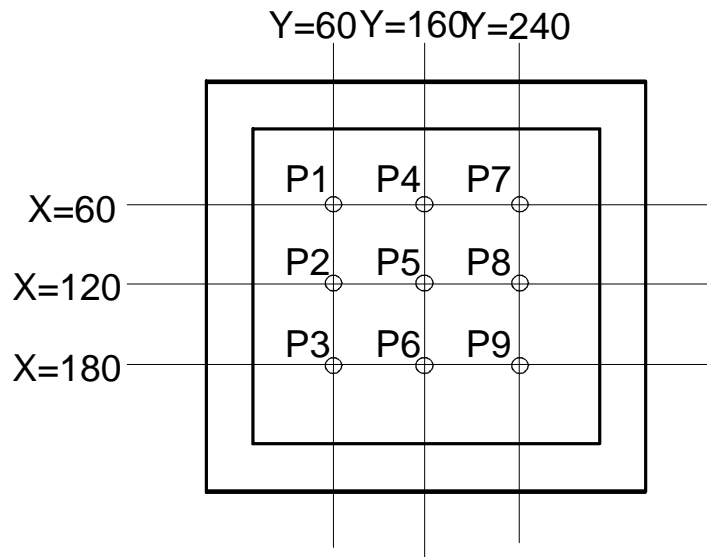

$$\left(\frac{\text{MAX BRIGHTNESS OR MIN BRIGHTNESS} - \text{AVERAGE BRIGHTNESS}}{\text{AVERAGE BRIGHTNESS}} \right) * 100$$

7. BLOCK DIAGRAM

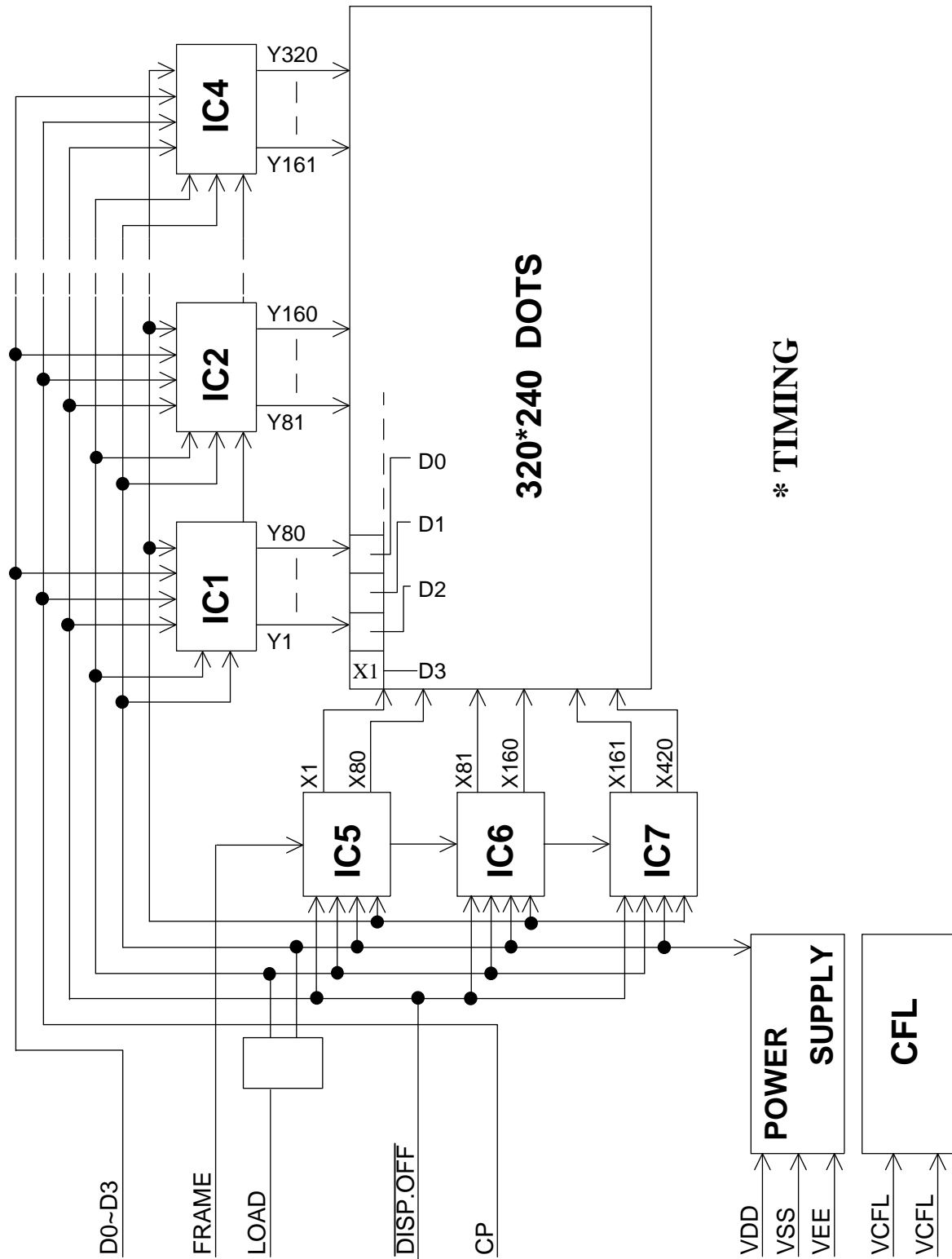

*** TIMING**

8. INTERFACE TIMING CHART

8.1 TIMING CHART

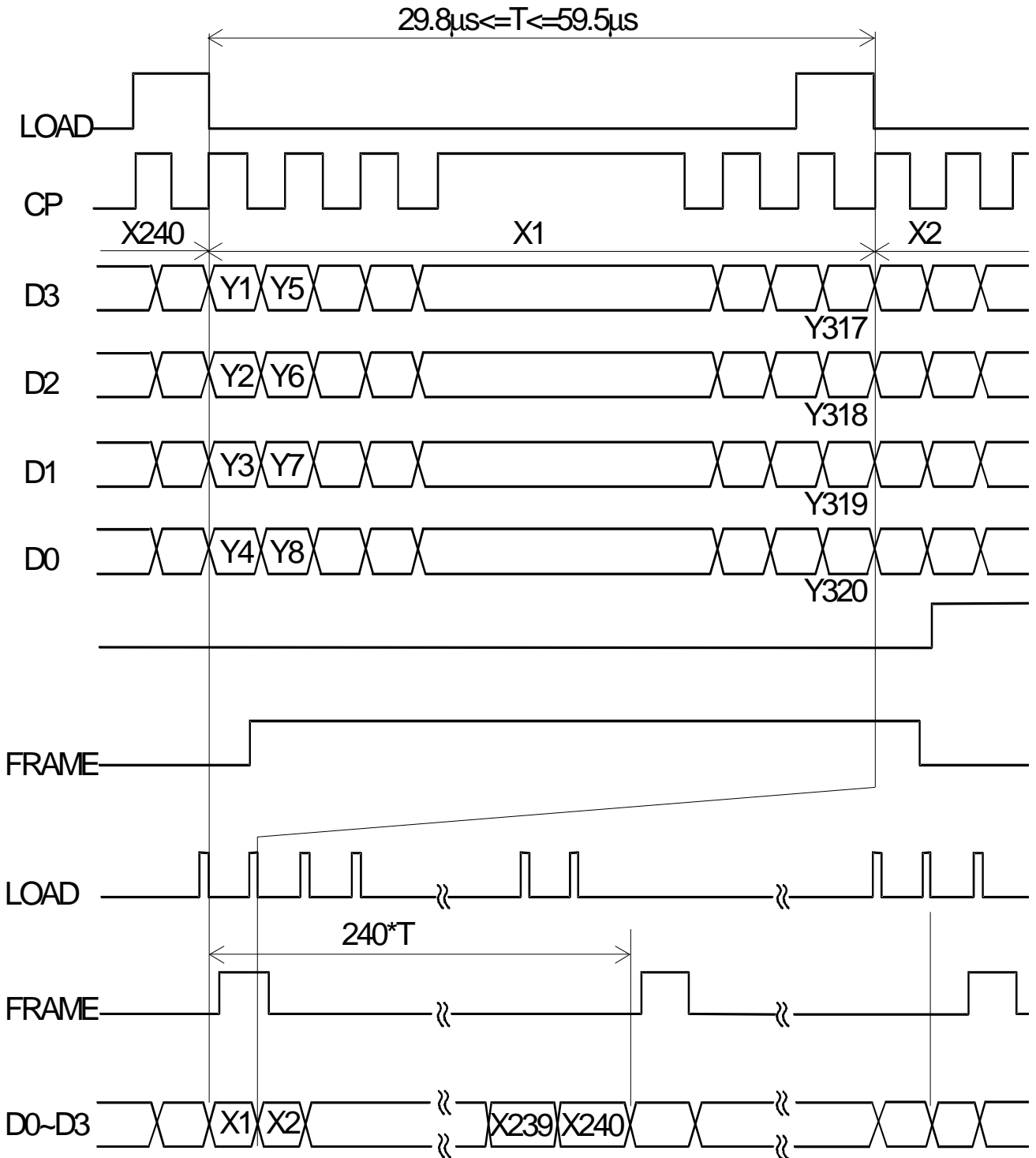

8.2 TIMING CHARACTERISTICS

$0^{\circ}\text{C} \leq T_a \leq 40^{\circ}\text{C}$

$V_{DD} = 5\text{V} \pm 5\%$

ITEM	SYMBOL	MIN.	TYP.	MAX.	UMIT
CLOCK FREQUENCY	FCP	-	-	6.5	MHz
CLOCK PULSE WIDTH	tW	63	-	-	ns
CLOCK RISE,FALL TIME	tr,tf	-	-	20	ns
DATA SET UP TIME	tDSU	50	-	-	ns
DATA HOLD TIME	tDHD	50	-	-	ns
LOAD SET UP TIME	tLSU	80	-	-	ns
LOAD→CLOCK TIME	tLC	80	-	-	ns
“FRAME” SET UP TIME	TSETUP	100	-	-	ns
“FRAME” HOLD TIME	THOLD	100	-	-	ns
“LOAD” PULSE WIDTH	tWC	125	-	-	ns

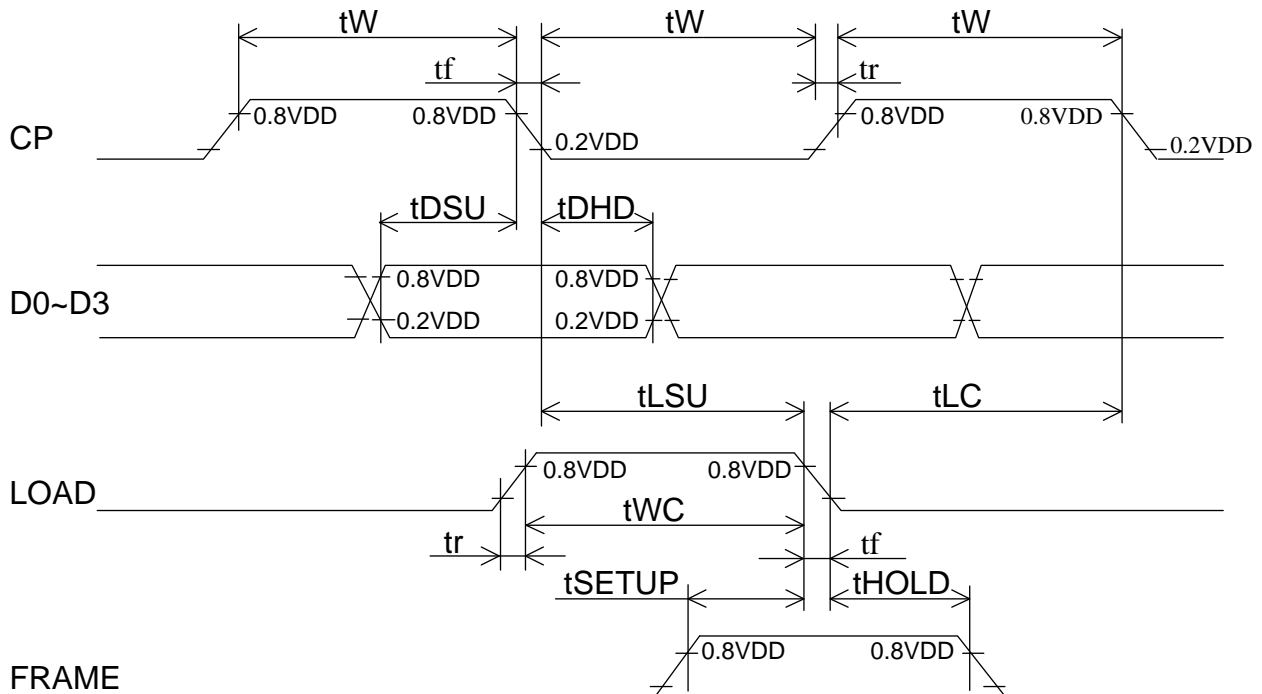

8.3 TIMING OF POWER SUPPLY AND INTERFACE SIGNAL AND INTERFACE SIGNAL

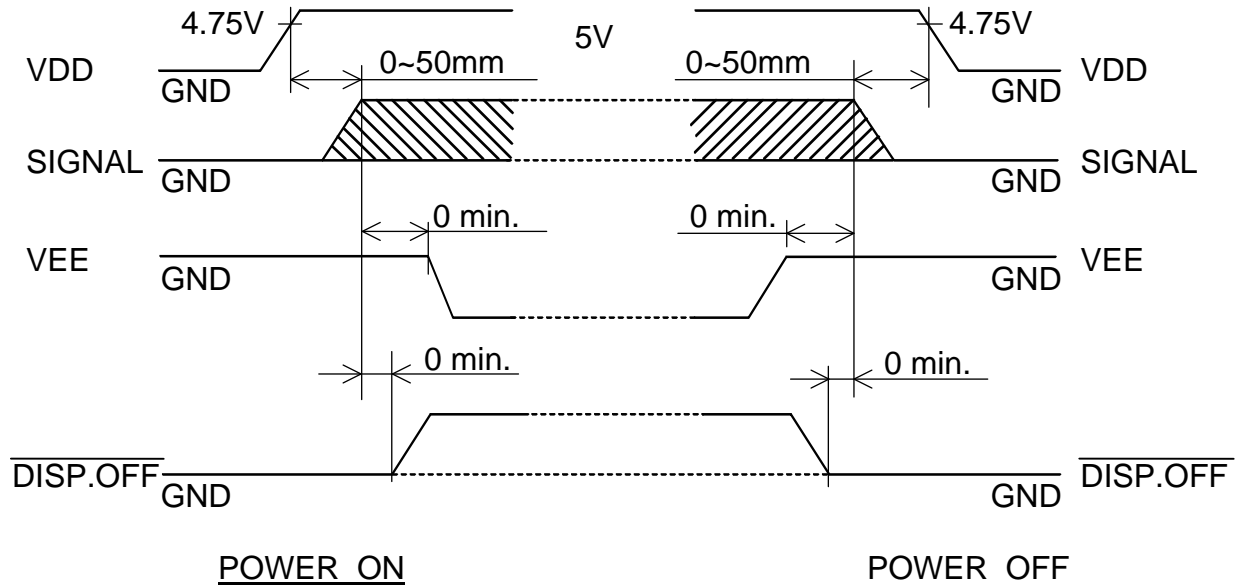

THE MISSING PIXELS MAY OCCUR WHEN THE LCM IS DRIVEN EXCEPT ABOVE POWER INTERFACE TIMING SEQUENCE.

8.4 POWER SUPPLY FOR LCM

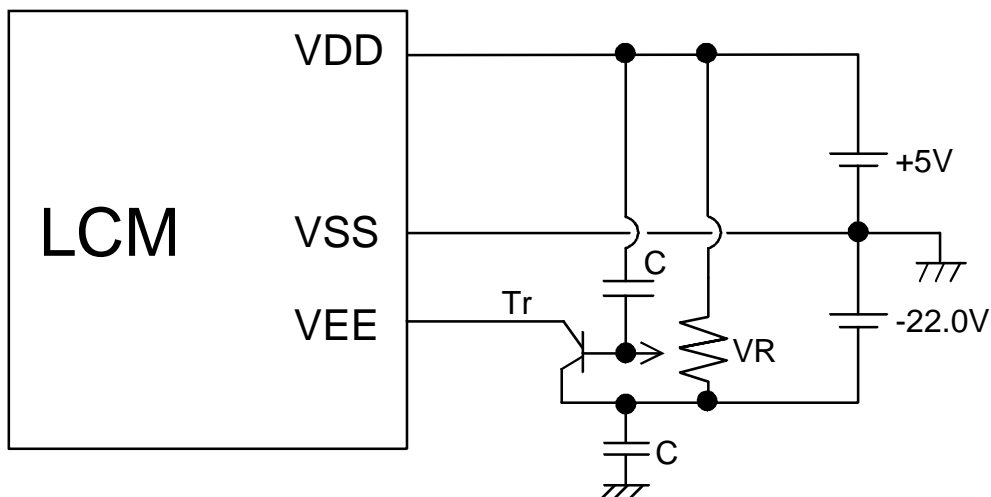

C :3.3 μ f(ALUMINUM ELECTROLYTIC CAPACITOR)
 VR:10~20K Ω
 Tr :2SA673APKC(hfe=100,IC=500mA)OR EQUIVALENT Tr.

9. DIMENSIONAL OUTLINE

9.1 DIMENSIONAL OUTLINE

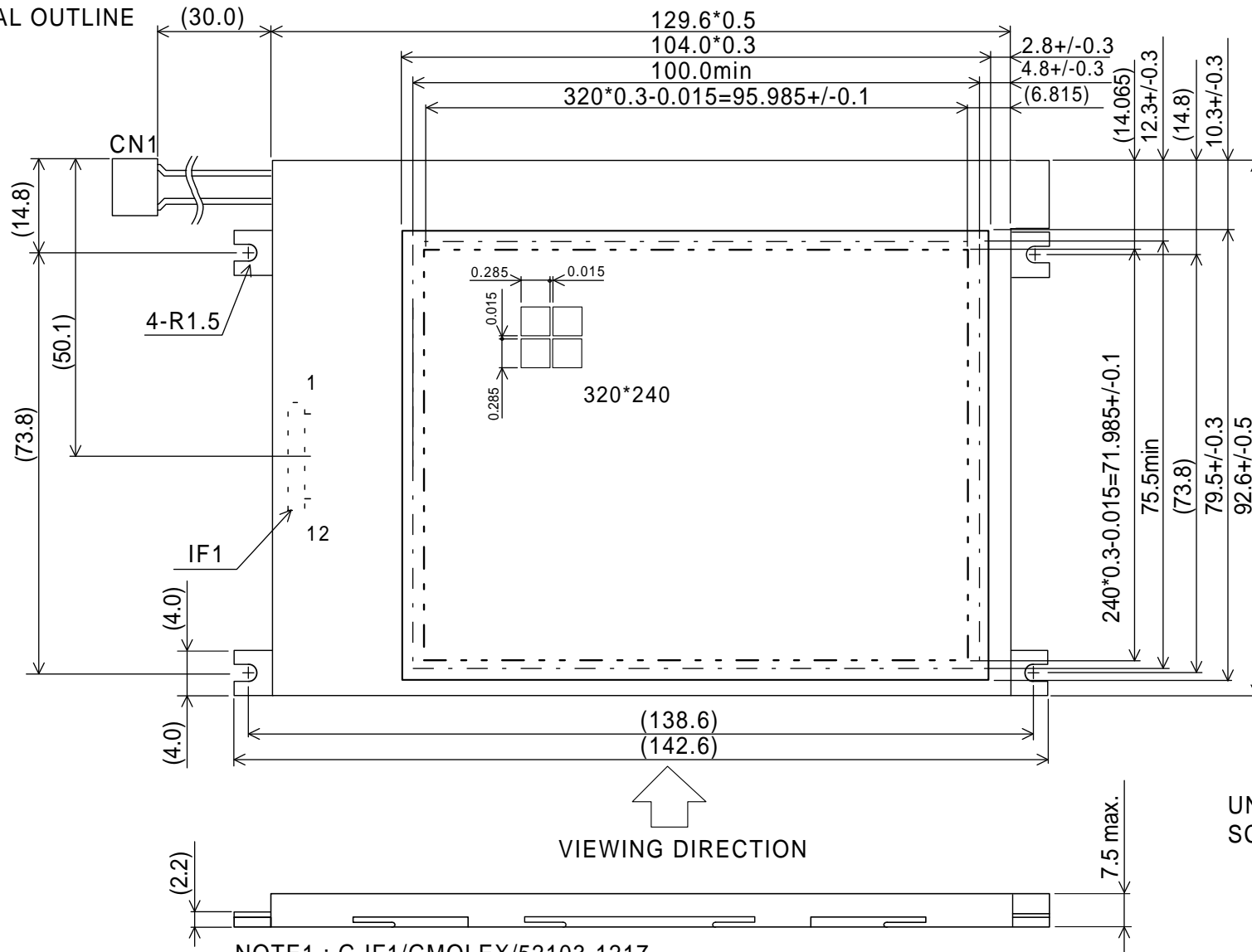

↑
VIEWING DIRECTION

UNIT : G mm
SCALE : GNTS

NOTE1 : G IF1/GMOLEX/52103-1217
CN1/GMITSUMI/M63M83-04

NOTE2 : GTHE COSMETIC INSPECTION SOULD BE NEGLECTED ON LCD WITH PROTECTIVE FILM.
NOTE3 : GTHE PROTECTIVE FILM SHOULD BE TAKEN OFF BEFORE USE.

9.2 DISPLAY PATTERN

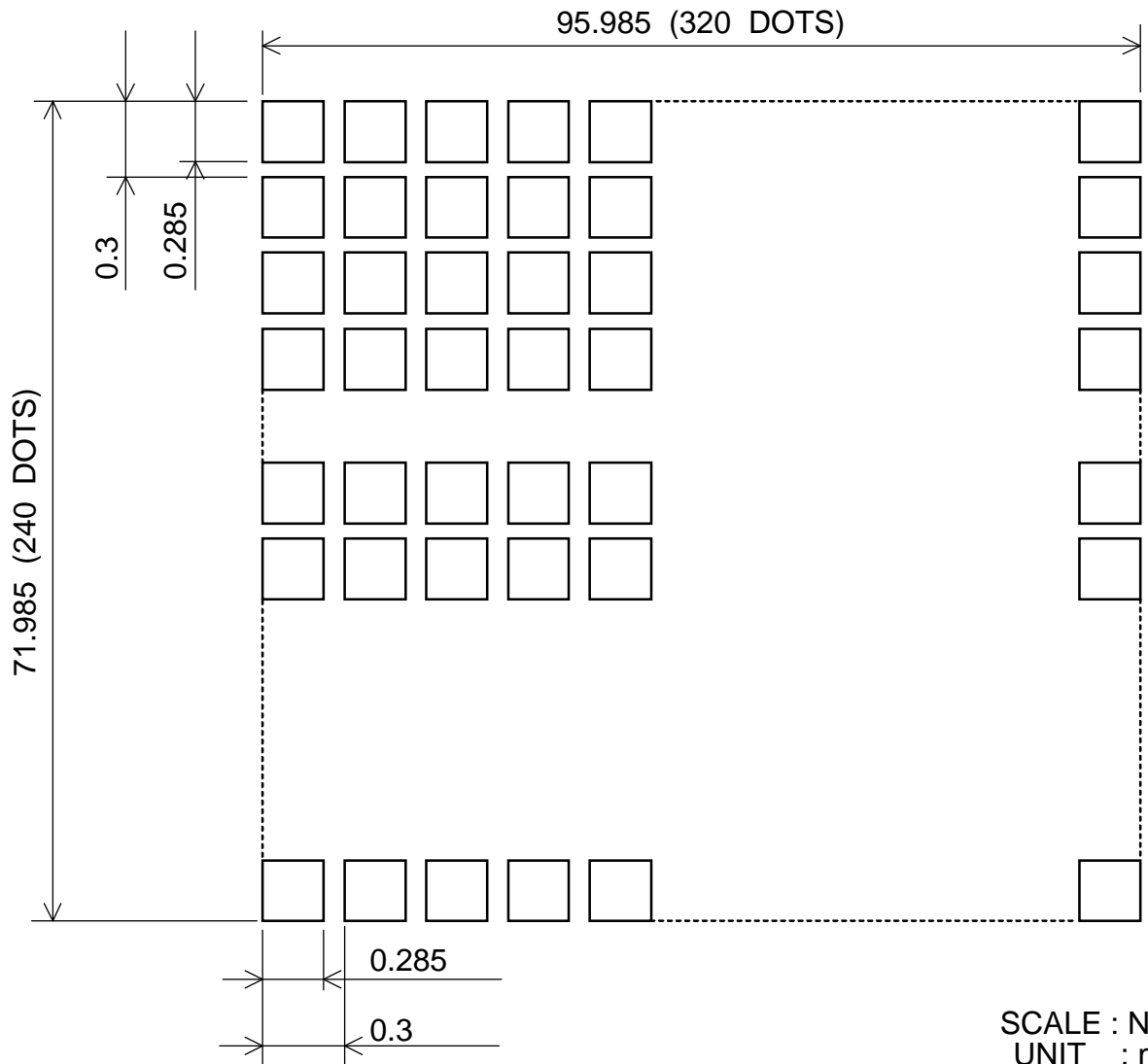

SCALE : NTS
 UNIT : mm
 MEASUREMENT TOLERANCE : +/-0.1

9.3 INTERNAL PIN CONNECTION

I/F1 :MOLEX/52103-1217

(SUITABLE FPC :1.0 Pitch,12 Pin,0.3')

INTERFACE		PIN NO.	SIGNAL	LEVEL	FUNCTION
LCM	I/F1	1	FRAME	H	FIRST LINE MARKER
		2	LOAD	H→L	DATA LATCH
		3	CP	H→L	DATA SHIFT
		4	VDD	-	POWER SUPPLY FOR LOGIC
		5	VSS	-	GND
		6	VEE	-	POWER SUPPLY FOR LC
		7	D0		DISPLAY DATA
		8	D1		
		9	D2	H/L	
		10	D3		
		11	$\overline{\text{DISP OFF}}$	H/L	H:ON/L:OFF
		12	NC	-	

INTERFACE		PIN NO.	SIGNAL	LEVEL	FUNCTION
LCM	CFL I/F1	1	H.V	-	CFL SUPPLY FOR CFL
		2	N.C	-	-
		3	N.C	-	-
		4	GND	-	CFL GND

CFL I/F1:MITSUMI/M63M83-04

SUITABLE CONNECTOR: MITSUMI M61M73-04

MITSUMI M60-04-30-1149(STRAIGHT)

MITSUMI M60-04-30-1349(ANGLE)

10. APPEARANCE STANDARD

10.1 APPEARANCE INSPECTION CONDITION

VISUAL INSPECTION SHOULD BE DONE UNDER THE FOLLOWING CONDITION.

- (1) IN THE DARK ROOM
- (2) WITH CFL PANEL LIGHTED WITH PRESCRIBED INVERTER CIRCUIT.
- (3) WITH EYES 25cm DISTAND FROM LCM
- (4) VIEWING ANGLE WITHIN 45 DEGREES FROM THE VERTICAL LINE TO THE CENTER OF LCD

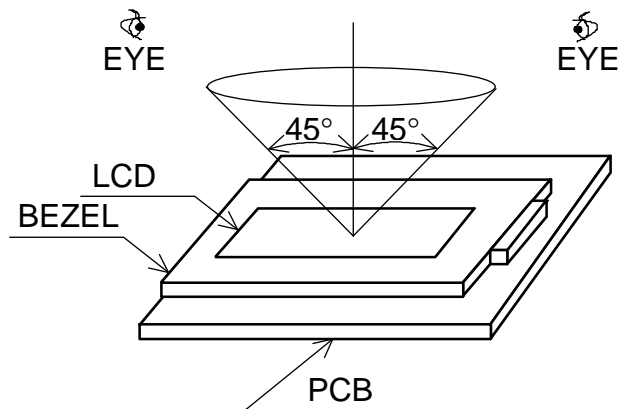

10.2 DEFINITION OF EACH ZONE

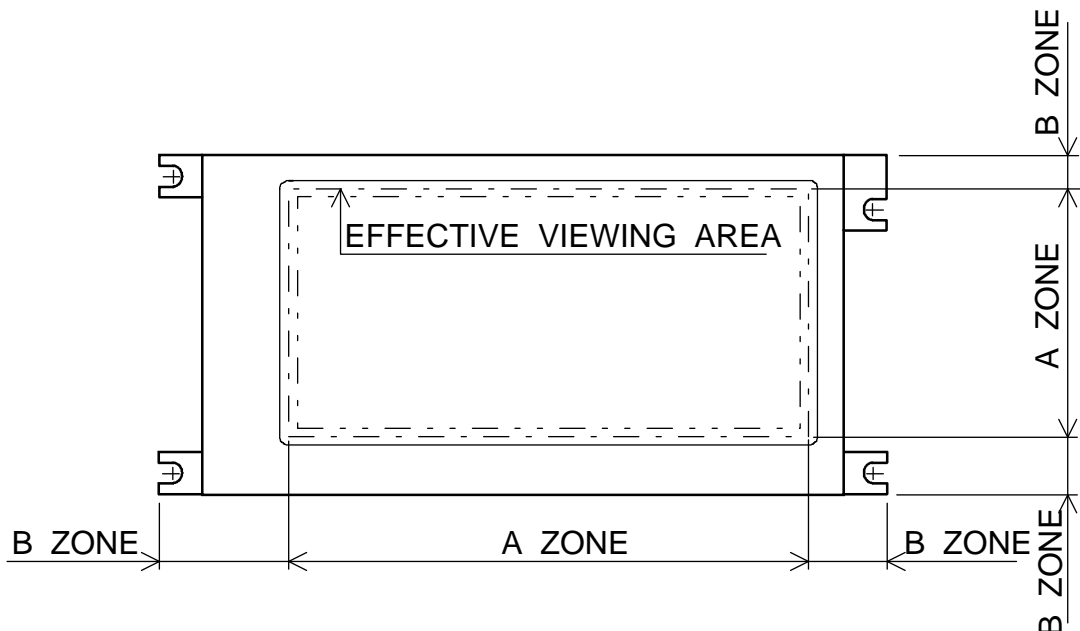

A ZONE: EFFECTIVE VIEWING AREA (REFER TO OUR DRAWING)

B ZONE: EXCEPT A ZONE

10.3 APPEARANCE SPECIFICATION

*) IF THE PROBLEM OCCURES, ABOUT THIS ITEM THE RESPONSIBLE PERSON OF BOTH PARTY (CUSTOMER AND HITACHI) WILL DISCUSS MORE DETAIL.

No.	ITEM	CRITERIA		A	B		
L	SCRATCHES	DISTINGUISHED ONE IS NOT ACCEPTABLE (TO BE JUDGE BY HITACHI LIMIT SAMPLE)		*	-		
	DENT	SAME AS ABOVE		*	-		
	WRINKLES IN POLARIZER	SAME AS ABOVE		*	*		
	BUBBLES	AVERAGE DIAMETER D(mm)	MAXIMUM NUMBER ACCEPTABLE		O	-	
		D<=0.2	IGNORE				
		0.2<D<=0.3	12				
		0.3<D<=0.5	3				
	NOTE(1)	0.5<D	NONE				
	C D	STAINS, FOREIGN MATERIALS DARK SPOT	FILAMENTOUS			O	*
			LENGTH L(mm)	WIDTH W(mm)	MAXIMUM NUMBER ACCEPTABLE		
L<=2.0			W<=0.03	IGNORE			
L<=3.0			0.03<W<=0.05	6			
-			0.05<W	NONE			
ROUND			O	*			
AVERAGE DIA- METER D(mm)					MAXIMUM NUMBER ACCEPTABLE	SPACE	
D<0.2					IGNORE	-	
0.2 <=D<0.33					8	10 mm	
0.33<=D					NONE	-	
THE WHOLE NUMBER		FILAMENTOUS + ROUND = 10					
THOSE WIPED OUT EASILY ARE ACCEPTABLE			O	O			
COLOR TONE		TO BE JUDGE BY HITACHI LIMIT SAMPLE		O	-		
COLOR UNIFORMITY		SAME AS ABOVE		O	-		
PINHOLE		(a+b)/2<=0.15MAX. NO. ACCEPTABLE IGNORE		O	-		
	0.15<(a+b)/2<=0.3MAX. NO.ACCEPTABLE<=10						
	C<=0.03	IGNORE					

No.	ITEM	CRITERIA				A	B
	CONTRAST IRREGULARITY (SPOT) NOTE(3) NOTE(2)	AVERAGE DIAMETER D(mm)	CONTRAST	MAXIMUM NUMBER ACCEPTABLE	DISTANCE	O	-
		D<0.25	TO BE JUDGE	IGNORE	-		
		0.25<D<=0.35	BY HITACHI	<=10	20mm		
		0.35<D<=0.5	LIMIT	<=4	20mm		
		0.5 <D	SAMPLE	NONE	-		
L C	CONTRAST IRREGULARITY (A PAIR OF SCRATCH) NOTE(3) NOTE(2)	THICKNESS T(mm)	LENGTH L(mm)	MAXIMUM NUMBER ACCEPTABLE	DISTANCE	O	-
		T<=0.25	L<=1.2	<=2	20mm		
		T<=0.2	L<=1.5	<=3	20mm		
		T<=0.15	L<=2.0	<=3	20mm		
		T<=0.1	L<=3.0	<=4	20mm		
	THE WHOLE NUMBER		<=6				
RUBBING SCRATCH	TO BE JUDGE BY HITACHI LIMIT SANPLE				*	-	

NOTE(1)

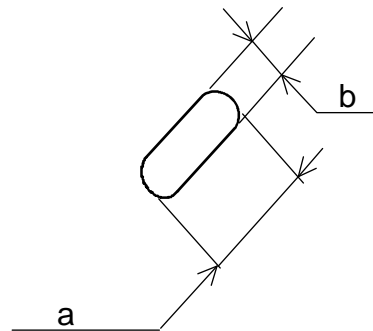
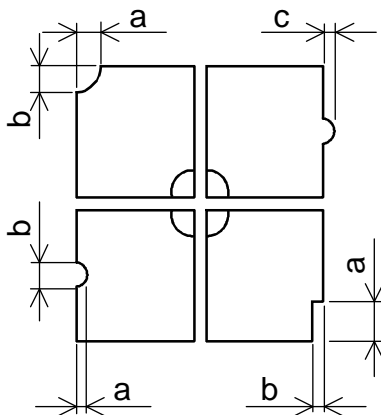

$$\frac{a+b}{2} = D \dots \text{AVERAGE DIAMETER}$$

C...SALIENT

NOTE 2 LCM BACKLIGHT ON.

NOTE 3 THERE ARE TWO SCRATCHES IN A PAIR.

11. PRECAUTION IN DESIGN

11.1 MOUNTING METHOD

SINCE THE MODULE IS SO CONSTRUCTED AS TO BE FIXED BY UTILIZING FITTING HOLES IN THE PRINTED CIRCUIT BOARD AS SHOWN BELOW, IT IS NECESSARY TO TAKE CONSIDERATION THE FOLLOWING ITEMS ON ATTACHMENT TO A FRAME.

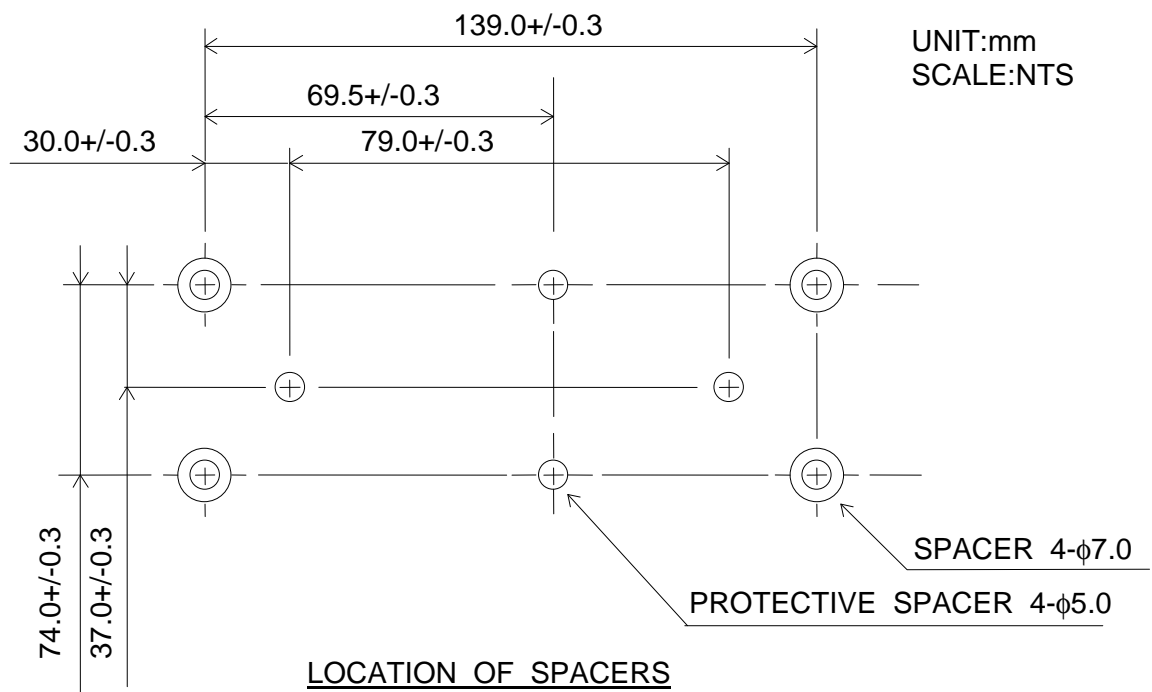
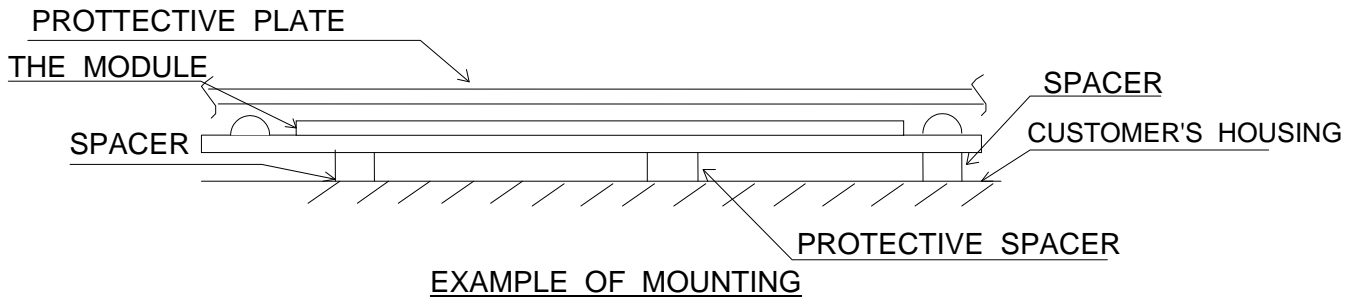

- (1) USE OF PROTECTIVE PLATE, MADE OF AN ACRYLIC PLATE, ETC, IN ORDER TO PROTECT A POLARIZER AND LC CELL.
- (2) TO PREVENT THE MODULE COVER FROM BEING PRESSED, THE SPACERS BETWEEN THE MODULE AND THE FITTING PLATES SHOULD BE LONGER THAN 0.5mm.
- (3) WE RECOMMEND YOU TO USE PROTECTIVE SPACER AS FIGURE FOR PROTECTING LCD MODULE FROM ANY KIND OF SHOCK TO YOUR SET.

11.2 LC DRIVING VOLTAGE(V_{EE}) AND VIEWING ANGLE RANGE.

SETTING V_{EE} OUT OF THE RECOMMENDED CONDITION WILL BE A CAUSE FOR A CHANGE OF VIEWING ANGLE RANGE.

11.3 CAUTION AGAINST STATIC CHARGE

AS THIS MODULE IS PROVIDED WITH C-MOS LSI, THE CARE TO TAKE SUCH A PRECAUTION AS TO GROUNDING THE OPERATOR'S BODY IS REQUIRED WHEN HANDLING IT.

11.4 POWER ON SEQUENCE

INPUT SIGNALS SHOULD NOT BE APPLIED TO LCD MODULE BEFORE POWER SUPPLY VOLTAGE IS APPLIED AND REACHES TO SPECIFIED VOLTAGE (5+/-0.25V) IF ABOVE SEQUENCE IS NOT KEPT, C-MOS LSI OF LCD MODULES MAY BE DAMAGED DUE TO LATCH UP PROBLEM.

11.5 PACKAGING

- (1) NO. LEAVING PRODUCTS IS PREFERABLE IN THE PLACE OF HIGH HUMIDITY FOR A LONG PERIOD OF TIME. FOR THEIR STORAGE IN THE PLACE WHERE TEMPERATURE IS 35°C OR HIGHER, SPECIAL CARE TO PREVENT THEM FROM HIGH HUMIDITY IS REQUIRED. A COMBINATION OF HIGH TEMPERATURE AND HIGH HUMIDITY MAY CAUSE THEM POLARIZATION DEGRADATION AS WELL AS BUBBLE GENERATION AND POLARIZER PEEL-OFF. PLEASE KEEP THE TEMPERATURE AND HUMIDITY WITHIN THE SPECIFIED RANGE FOR USE AND STORING.
- (2) SINCE UPPER POLARIZERS AND LOWER ALUMINUM PLATES TEND TO BE EASILY DAMAGED, THEY SHOULD BE HANDLED WITH FULL CARE SO AS NOT TO GET THEM TOUCHED, PUSHED OR RUBBED BY A PIECE OF GLASS. TWEEZERS AND ANYTHING ELSE WHICH ARE HARDER THAN A PENCIL LEAD 3H.
- (3) AS THE ADHESIVES USED FOR ADHERING UPPER/LOWER POLARIZES AND ALUMINUM PLATES ARE MADE OF ORGANIC SUBSTANCES WHICH WILL BE DETERIORATED BY A CHEMICAL REACTION WITH SUCH CHEMICALS AS ACETONE, TULUENE ETHANOLE AND ISOPROPYLALCOHIL. THE FOLLOWING SOLVENTS ARE RECOMMENDED FOR USE:
NORMAL HEXANE
PLEASE CONTACT US WHEN IT IS NECESSARY FOR YOU TO USE CHEMICALS OTHER THAN THE ABOVE.
- (4) LIGHTLY WIPE TO CLEAN THE DIRTY SURFACE WITH ABSORBENT COTTON WASTE OR OTHER SOFT MATERIAL LIKE CHAMOIS, SOAKED IN THE CHEMICALS RECOMMENDED WITHOUT SCRUBBING IT HARDLY. TO PREVENT THE DISPLAY SURFACE FROM DAMAGE AND KEEP THE APPEARANCE IN GOOD STATE, IT IS SUFFICIENT, IN GENERAL, TO WIPE IT WITH ABSORBENT COTTON.

- (5) IMMEDIATELY WIPE OFF SALIVA OFF SALIVA OR WATER DROP ATTACHED ON THE DISPLAY AREA BECAUSE ITS LONG PERIOD ADHERENCE MAY CAUSE DEFORMATION OR FADED COLOR ON THE SPOT.
- (6) FOGY DEW DEPOSITED ON THE SURFACE AND CONTACT TERMINALS DUE TO COLDNESS WILL BE CAUSE FOR POLARIZER DAMAGE, STAIN AND DIRT ON PRODUCT. WHEN NECESSARY TO TAKE OUT THE PRODUCTS FROM SOME PLACE AT LOW TEMPERATURE FOR TEST, ETC. IT IS REQUIRED THEM TO BE WARMED UP IN A CONTAINER ONCE AT THE TEMPERATURE HIGHER THAN THAT OF ROOM.
- (7) TOUCHING THE DISPLAY AREA AND CONTACT TERMINALS WITH BARE HANDS AND CONTAMINATING THEM ARE PROHIBITED, BECAUSE THE STAIN ON THE DISPLAY AREA AND POOR INSULATION BETWEEN TERMINALS ARE OFTEN CAUSED BY BEING TOUCHED BY BARE HANDS. (THERE ARE SOME COSMETICS DETRIMENTAL TO POLARIZERS.)
- (8) IN GENERAL THE QUALITY OF GLASS IS FRAGILE SO THAT IT TENDS TO BE CRACKED OR CHIPPED IN HANDLING,SPECIALY ON ITS PERIPHERY DOWN, ECT.

11.6 CAUTION FOR OPERATION

- (1) IT IS AN INDISPENSABLE CONDITION TO DRIVE LCD'S WITHIN THE SPECIFIED VOLTAGE LIMIT SINCE THE HIGHER VOLTAGE THAN THE LIMIT CAUSES THE SHORTER LCD LIFE.AN ELECTROCHEMICAL REACTION DUE TO DIRECT CURRENT CAUSES LCD'S UNDESIRABLE DETERIORATION, SO THAT THE USE OF DIRECT CURRENT DRIVER SHOULD BE AVOIDED.
- (2) RESPONSE TIME WILL BE EXTREMELY DELAYED AT LOWER TEMPERATURE THAN THE OPERATING TEMPERATURE RANGE AND ON THE OTHER HAND AT HIGHER TEMPERATURE LCD'S SHOW DARK BLUE COLOR IN HEM.HOWEVER THOSE PHENOMENA DO NOT MEAN MALFUNCTION OR OUT OF ORDER WITH LCD'S WHICH WILL COME BACK IN THE SPECIFIED OPERATING TEMPER ATURE RANGE.
- (3) IF THE DISPLAY AREA IS PUSHED HARD DURING OPERATION,SOME FONT WILL BE ABNORMALLY DISPLAYED BUT IT RESUMES NORMAL CONDITION AFTER TURNING OFF ONCE.

- (4) A SLIGHT DEW DEPOSITING ON TERMINALS IS A CAUSE FOR ELECTROCHEMICAL REACTION RESULTING IN TERMINAL OPER CIRCUIT. USAGE UNDER THE RELATIVE CONDITION OF 40°C 50%RH LESS IS REQUIRED.

11.7 STORAGE

IN CASE OF STORING FOR A LONG PERIOD TIME (FOR INSTANCE, FOR YEARS) FOR THE PURPOSE OF REPLACEMENT USE, THE FOLLOWING WAYS ARE RECOMMENDED.

- (1) STORAGE IN A POLYETHYLENE BAG WITH THE OPENING SEALED SO AS NOT TO ENTER FRESH AIR OUTSIDE IN IT, AND WITH NO DESICCANT.
- (2) PLACING IN A DARK PLACE WHERE NEITHER EXPOSURE TO DIRECT SUNLIGHT NOR LIGHT IS, KEEPING TEMPERATURE IN THE RANGE FOR 0°C TO 35°C.
- (3) STORING WITH NO TOUCH ON POLARIZER SURFACE BY ANYTHING ELSE.
(IT IS RECOMMENDED TO STORE THEM AS THEY HAVE BEEN CONTAINED IN THE INNER CONTAINER AT THE TIME OF DELIVERY FOR US.)

11.8 SAFETY

- (1) IT IS RECOMMENDABLE TO CRASH DAMAGED OR UNNECESSARY LCD'S INTO PIECES AND WASH OFF LIQUID CRYSTAL BY EITHER OF SOLVENTS SUCH AS ACETONE AND ETHANOL, WHICH SHOULD UP LATER.
- (2) WHEN ANY LIQUID LEAKED OUT OF A DAMAGED GLASS CELL IN CONTACT WITH YOUR HANDS, PLEASE WASH IT OFF WELL WITH SOAP AND WATER.

12. DESIGNATION OF LOT MARK

LOT MARK

LOT MARK IS CONSISTED OF 4 DIGIT NUMBER.

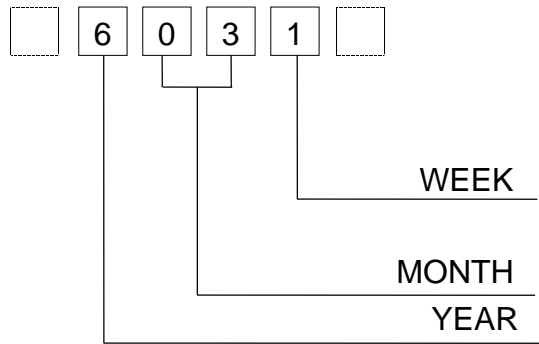

YEAR	FIGURE IN LOT MARK
1996	6
1997	7
1998	8
1999	9
2000	0

MONTH	FIGURE IN LOT MARK	MONTH	FIGURE IN LOT MARK
JAN.	01	JULY.	07
FEB.	02	AUG.	08
MAR.	03	SEPT.	09
APR.	04	OCT.	10
MAY.	05	NOV.	11
JUNE.	06	DEC.	12

WEEK (DAY IN CALENDAR)	FIGURE IN LOT MARK
01~07	1
08~14	2
15~21	3
22~28	4
29~31	5

LOCATION OF LOT MARK : ON THE BACK SIDE OF LCM

6 0 3 1 T

T:MADE IN TAIWAN.

13. PRECAUTION FOR USE

- (1) A LIMIT SAMPLE SHOULD BE PROVIDED BY THE BOTH PARTIES ON AN OCCASION WHEN THE BOTH PARTIES AGREED ITS NECESSITY. JUDGMENT BY A LIMIT SAMPLE SHALL TAKE EFFECT AFTER THE LIMIT SAMPLE HAS BEEN ESTABLISHED AND CONFIRMED BY THE BOTH PARTIES.
- (2) ON THE FOLLOWING OCCASION, THE HANDLING OF THE PROBLEM SHOULD BE DECIDED THROUGH DISCUSSION AND AGREEMENT BETWEEN RESPONSIBLE PERSONS OF THE BOTH PARTIES.
 - (1) WHEN A QUESTION IS ARISEN IN THE SPECIFICATIONS.
 - (2) WHEN A NEW PROBLEM IS ARISEN WHICH IS NOT SPECIFIED IN THIS SPECIFICATIONS.
 - (3) WHEN AN INSPECTION SPECIFICATIONS CHANGE OR OPERATING CONDITION CHANGE IN CUSTOMER IS REPORTED TO HITACHI, AND SOME PROBLEM IS ARISEN IN THIS SPECIFICATION DUE TO THE CHANGE.
 - (4) WHEN A NEW PROBLEM IS ARISEN AT THE CUSTOMER'S OPERATING SET FOR SAMPLE EVALUATION IN THE CUSTOMER SITE.

THE PRECAUTION THAT SHOULD BE OBSERVED WHEN HANDLING LCM HAVE BEEN EXPLAIND ABOVE. IF ANY POINTS ARE UNCLEAR OF IF YOU HAVE ANY REQUESTS,PLEASE CONTACT HITACHI.