

NB4N527S

3.3V, 2.5Gb/s Dual AnyLevel™ to LVDS Receiver/Driver/Buffer/Translator with Internal Input Termination

NB4N527S is a clock or data Receiver/Driver/Buffer/Translator capable of translating AnyLevel™ input signal (LVPECL, CML, HSTL, LVDS, or LVTTTL/LVCMOS) to LVDS. Depending on the distance, noise immunity of the system design, and transmission line media, this device will receive, drive or translate data or clock signals up to 2.5 Gb/s or 1.5 GHz, respectively.

The NB4N527S has a wide input common mode range of $GND + 50\text{ mV}$ to $V_{CC} - 50\text{ mV}$ combined with two $50\ \Omega$ internal termination resistors is ideal for translating differential or single-ended data or clock signals to 350 mV typical LVDS output levels without use of any additional external components (Figure 6).

The device is offered in a small 3 mm x 3 mm QFN-16 package. NB4N527S is targeted for data, wireless and telecom applications as well as high speed logic interface where jitter and package size are main requirements. Application notes, models, and support documentation are available on www.onsemi.com.

- Maximum Input Clock Frequency up to 1.5 GHz
- Maximum Input Data Rate up to 2.5 Gb/s (Figure 5)
- 470 ps Maximum Propagation Delay\
- 1 ps Maximum RMS Jitter
- 140 ps Maximum Rise/Fall Times
- Single Power Supply; $V_{CC} = 3.3\text{ V} \pm 10\%$
- Temperature Compensated TIA/EIA-644 Compliant LVDS Outputs
- Internal $50\ \Omega$ Termination Resistor per Input Pin
- $GND + 50\text{ mV}$ to $V_{CC} - 50\text{ mV}$ V_{CMR} Range
- Pb-Free Packages are Available

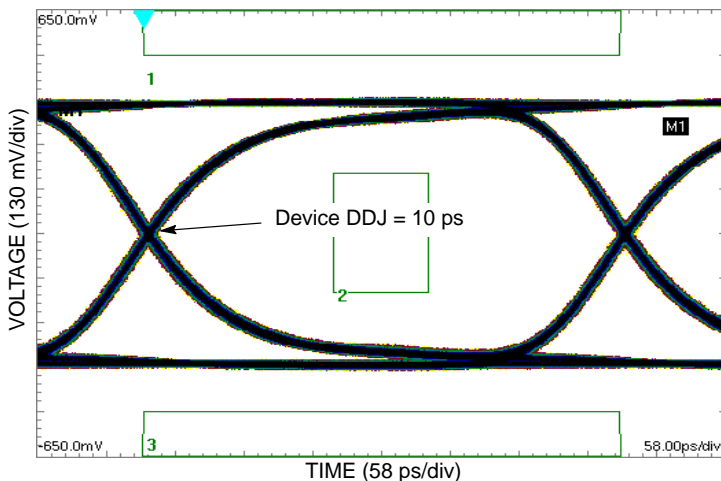

Figure 2. Typical Output Waveform at 2.488 Gb/s with PRBS $2^{23}-1$ ($V_{INPP} = 400\text{ mV}$; Input Signal DDJ = 14 ps)



ON Semiconductor®

<http://onsemi.com>

MARKING DIAGRAM*



QFN-16
MN SUFFIX
CASE 485G

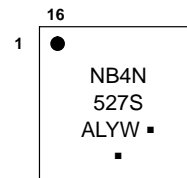

- A = Assembly Location
- L = Wafer Lot
- Y = Year
- W = Work Week
- = Pb-Free Package

(Note: Microdot may be in either location)

*For additional marking information, refer to Application Note AND8002/D.

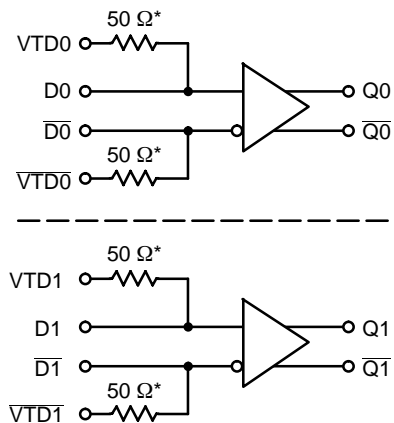

Figure 1. Functional Block Diagram

*RTIN

ORDERING INFORMATION

See detailed ordering and shipping information in the package dimensions section on page 9 of this data sheet.

NB4N527S

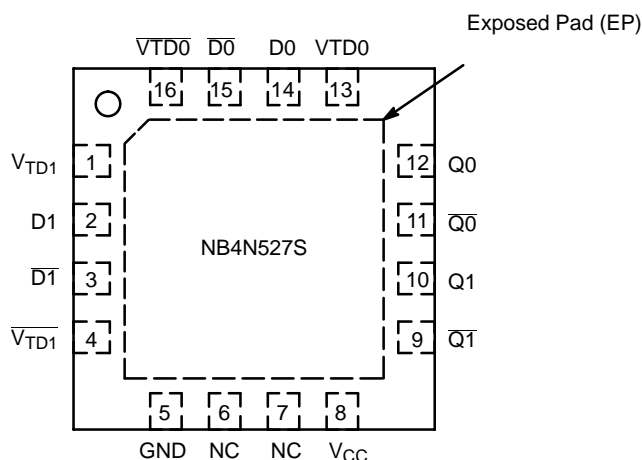

Figure 3. Pin Configuration (Top View)

Table 1. PIN DESCRIPTION

Pin	Name	I/O	Description
1	VTD1	-	Internal 50 Ω termination pin for D1. (R_{TIN})
2	D1	LVPECL, CML, LVDS, LVCMOS, LVTTTL, HSTL	Noninverted differential clock/data D1 input (Note 1).
3	$\overline{D1}$	LVPECL, CML, LVDS, LVCMOS, LVTTTL, HSTL	Inverted differential clock/data $\overline{D1}$ input (Note 1).
4	$\overline{VTD1}$	-	Internal 50 Ω termination pin for $\overline{D1}$. (R_{TIN})
5	GND	-	0 V. Ground.
6, 7	NC		No connect.
8	V_{CC}		Positive Supply Voltage.
9	$\overline{Q1}$	LVDS Output	Inverted D1 output. Typically loaded with 100 Ω receiver termination resistor across differential pair.
10	Q1	LVDS Output	Noninverted D1 output. Typically loaded with 100 Ω receiver termination resistor across differential pair.
11	$\overline{Q0}$	LVDS Output	Inverted D0 output. Typically loaded with 100 Ω receiver termination resistor across differential pair.
12	Q0	LVDS Output	Noninverted D0 output. Typically loaded with 100 Ω receiver termination resistor across differential pair.
13	VTD0	-	Internal 50 Ω termination pin for D0.
14	D0	LVPECL, CML, LVDS, LVCMOS, LVTTTL, HSTL	Noninverted differential clock/data D0 input (Note 1).
15	$\overline{D0}$	LVPECL, CML, LVDS, LVCMOS, LVTTTL, HSTL	Inverted differential clock/data $\overline{D0}$ input (Note 1).
16	$\overline{VTD0}$	-	Internal 50 Ω termination pin for $\overline{D0}$.
EP			Exposed pad. EP on the package bottom is thermally connected to the die improved heat transfer out of package. The pad is not electrically connected to the die, but is recommended to be soldered to GND on the PCB.

1. In the differential configuration when the input termination pins ($VTD0/V\overline{TD0}$, $VTD1/V\overline{TD1}$) are connected to a common termination voltage or left open, and if no signal is applied on D0/ $\overline{D0}$, D1/ $\overline{D1}$ input, then the device will be susceptible to self-oscillation.

NB4N527S

Table 2. ATTRIBUTES

Characteristics		Value
Moisture Sensitivity (Note 2)		Level 1
Flammability Rating	Oxygen Index: 28 to 34	UL 94 V-0 @ 0.125 in
ESD Protection	Human Body Model Machine Model Charged Device Model	> 2 kV > 200 V > 1 kV
Transistor Count		281
Meets or exceeds JEDEC Spec EIA/JESD78 IC Latchup Test		

2. For additional information, see Application Note AND8003/D.

Table 3. MAXIMUM RATINGS

Symbol	Parameter	Condition 1	Condition 2	Rating	Unit
V _{CC}	Positive Power Supply	GND = 0 V		3.8	V
V _I	Positive Input	GND = 0 V	V _I = V _{CC}	3.8	V
I _{IN}	Input Current Through R _T (50 Ω Resistor)	Static Surge		35 70	mA mA
I _{OSC}	Output Short Circuit Current Line-to-Line (Q to \bar{Q}) Line-to-End (Q or \bar{Q} to GND)	Q or \bar{Q} to GND Q to \bar{Q}	Continuous Continuous	12 24	mA
T _A	Operating Temperature Range	QFN-16		-40 to +85	°C
T _{stg}	Storage Temperature Range			-65 to +150	°C
θ _{JA}	Thermal Resistance (Junction-to-Ambient) (Note 3)	0 lfpm 500 lfpm	QFN-16 QFN-16	41.6 35.2	°C/W °C/W
θ _{JC}	Thermal Resistance (Junction-to-Case)	1S2P (Note 3)	QFN-16	4.0	°C/W
T _{sol}	Wave Solder	Pb Pb-Free		265 265	°C

Stresses exceeding Maximum Ratings may damage the device. Maximum Ratings are stress ratings only. Functional operation above the Recommended Operating Conditions is not implied. Extended exposure to stresses above the Recommended Operating Conditions may affect device reliability.

3. JEDEC standard multilayer board – 1S2P (1 signal, 2 power) with 8 filled thermal vias under exposed pad.

NB4N527S

Table 4. DC CHARACTERISTICS, CLOCK INPUTS, LVDS OUTPUTS $V_{CC} = 3.0\text{ V to }3.6\text{ V}$, $GND = 0\text{ V}$, $T_A = -40^\circ\text{C to }+85^\circ\text{C}$

Symbol	Characteristic	Min	Typ	Max	Unit
I_{CC}	Power Supply Current (Note 8)		40	53	mA

DIFFERENTIAL INPUTS DRIVEN SINGLE-ENDED (Figures 11, 12, 16, and 18)

V_{th}	Input Threshold Reference Voltage Range (Note 7)	GND +100		$V_{CC} - 100$	mV
V_{IH}	Single-ended Input HIGH Voltage	$V_{th} + 100$		V_{CC}	mV
V_{IL}	Single-ended Input LOW Voltage	GND		$V_{th} - 100$	mV

DIFFERENTIAL INPUTS DRIVEN DIFFERENTIALLY (Figures 7, 8, 9, 10, 17, and 19)

V_{IHD}	Differential Input HIGH Voltage	100		V_{CC}	mV
V_{ILD}	Differential Input LOW Voltage	GND		$V_{CC} - 100$	mV
V_{CMR}	Input Common Mode Range (Differential Configuration)	GND + 50		$V_{CC} - 50$	mV
V_{ID}	Differential Input Voltage ($V_{IHD} - V_{ILD}$)	100		V_{CC}	mV
R_{TIN}	Internal Input Termination Resistor	40	50	60	Ω

LVDS OUTPUTS (Note 4)

V_{OD}	Differential Output Voltage	250		450	mV
ΔV_{OD}	Change in Magnitude of V_{OD} for Complementary Output States (Note 9)	0	1	25	mV
V_{OS}	Offset Voltage (Figure 15)	1125		1375	mV
ΔV_{OS}	Change in Magnitude of V_{OS} for Complementary Output States (Note 9)	0	1	25	mV
V_{OH}	Output HIGH Voltage (Note 5)		1425	1600	mV
V_{OL}	Output LOW Voltage (Note 6)	900	1075		mV

NOTE: Device will meet the specifications after thermal equilibrium has been established when mounted in a test socket or printed circuit board with maintained transverse airflow greater than 500 lfm. Electrical parameters are guaranteed only over the declared operating temperature range. Functional operation of the device exceeding these conditions is not implied. Device specification limit values are applied individually under normal operating conditions and not valid simultaneously.

4. LVDS outputs require 100 Ω receiver termination resistor between differential pair. See Figure 14.
5. $V_{OHmax} = V_{OSmax} + \frac{1}{2} V_{ODmax}$.
6. $V_{OLmax} = V_{OSmin} - \frac{1}{2} V_{ODmax}$.
7. V_{th} is applied to the complementary input when operating in single-ended mode.
8. Input termination pins open, Dx/Dx at the DC level within V_{CMR} and output pins loaded with $R_L = 100\ \Omega$ across differential.
9. Parameter guaranteed by design verification not tested in production.

NB4N527S

Table 5. AC CHARACTERISTICS $V_{CC} = 3.0\text{ V to }3.6\text{ V}$, $GND = 0\text{ V}$; (Note 10)

Symbol	Characteristic	-40°C			25°C			85°C			Unit
		Min	Typ	Max	Min	Typ	Max	Min	Typ	Max	
V_{OUTPP}	Output Voltage Amplitude (@ $V_{INPPmin}$) $f_{in} \leq 1.0\text{ GHz}$ (Figure 4) $f_{in} = 1.5\text{ GHz}$	220 200	350 300		220 200	350 300		220 200	350 300		mV
f_{DATA}	Maximum Operating Data Rate	1.5	2.5		1.5	2.5		1.5	2.5		Gb/s
t_{PLH} , t_{PHL}	Differential Input to Differential Output Propagation Delay	270	370	470	270	370	470	270	370	470	ps
t_{SKEW}	Duty Cycle Skew (Note 11) Within Device Skew (Note 17) Device-to-Device Skew (Note 15)		8 5 30	45 25 100		8 5 30	45 25 100		8 5 30	45 25 100	ps
t_{JITTER}	RMS Random Clock Jitter (Note 13) $f_{in} = 1.0\text{ GHz}$ $f_{in} = 1.5\text{ GHz}$ Deterministic Jitter (Note 14) $f_{DATA} = 622\text{ Mb/s}$ $f_{DATA} = 1.5\text{ Gb/s}$ $f_{DATA} = 2.488\text{ Gb/s}$ Crosstalk Induced Jitter (Note 16)		0.5 0.5 6 7 10 20	1 1 20 20 25 40		0.5 0.5 6 7 10 20	1 1 20 20 25 40		0.5 0.5 6 7 10 20	1 1 20 20 25 40	ps
V_{INPP}	Input Voltage Swing/Sensitivity (Differential Configuration) (Note 12)	100		$V_{CC}-GND$	100		$V_{CC}-GND$	100		$V_{CC}-GND$	mV
t_r t_f	Output Rise/Fall Times @ 250 MHz (20% – 80%) Q, \bar{Q}	60	100	140	60	100	140	60	100	140	ps

NOTE: Device will meet the specifications after thermal equilibrium has been established when mounted in a test socket or printed circuit board with maintained transverse airflow greater than 500 lpm. Electrical parameters are guaranteed only over the declared operating temperature range. Functional operation of the device exceeding these conditions is not implied. Device specification limit values are applied individually under normal operating conditions and not valid simultaneously.

10. Measured by forcing $V_{INPPmin}$ with 50% duty cycle clock source and $V_{CC} - 1400\text{ mV}$ offset. All loading with an external $R_L = 100\ \Omega$ across "D" and " \bar{D} " of the receiver. Input edge rates 150 ps (20%–80%).
11. See Figure 13 differential measurement of $t_{skew} = |t_{PLH} - t_{PHL}|$ for a nominal 50% differential clock input waveform @ 250 MHz.
12. Input voltage swing is a single-ended measurement operating in differential mode.
13. RMS jitter with 50% duty cycle input clock signal.
14. Deterministic jitter with input NRZ data at PRBS $2^{23}-1$ and K28.5.
15. Skew is measured between outputs under identical transition @ 250 MHz.
16. Crosstalk induced jitter is the additive deterministic jitter to channel one with channel two active both running at 622 Gb/s PRBS $2^{23}-1$ as an asynchronous signals.
17. The worst case condition between $Q0/\bar{Q}0$ and $Q1/\bar{Q}1$ from either $D0/\bar{D}0$ or $D1/\bar{D}1$, when both outputs have the same transition.

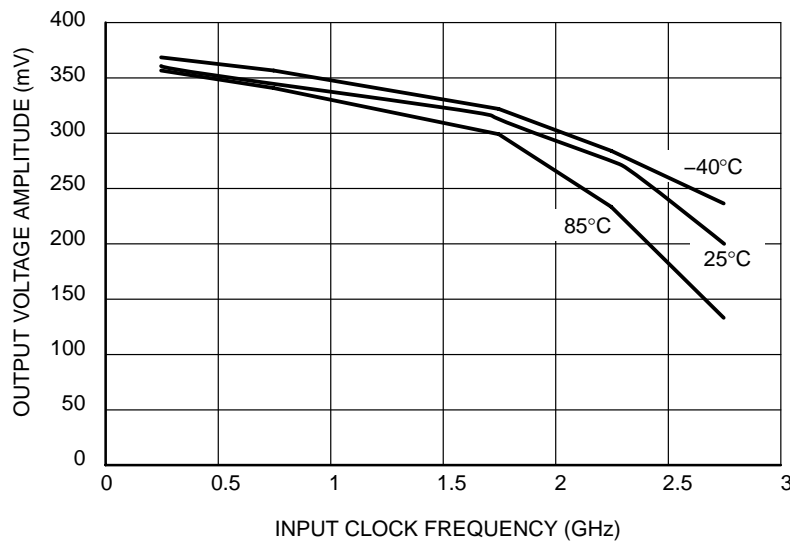

Figure 4. Output Voltage Amplitude (V_{OUTPP}) versus Input Clock Frequency (f_{in}) and Temperature (@ $V_{CC} = 3.3\text{ V}$)

NB4N527S

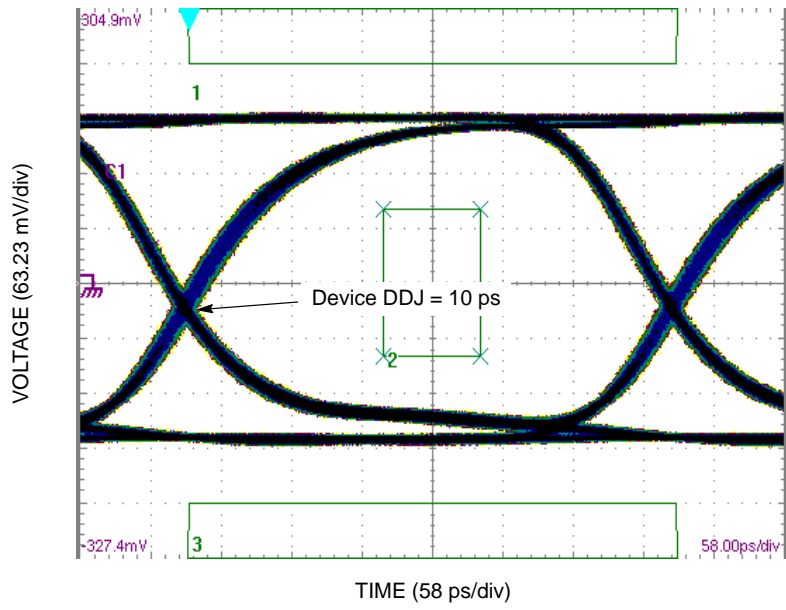

Figure 5. Typical Output Waveform at 2.488 Gb/s with PRBS $2^{23}-1$ and OC48 mask ($V_{INPP} = 100$ mV; Input Signal DDJ = 14 ps)

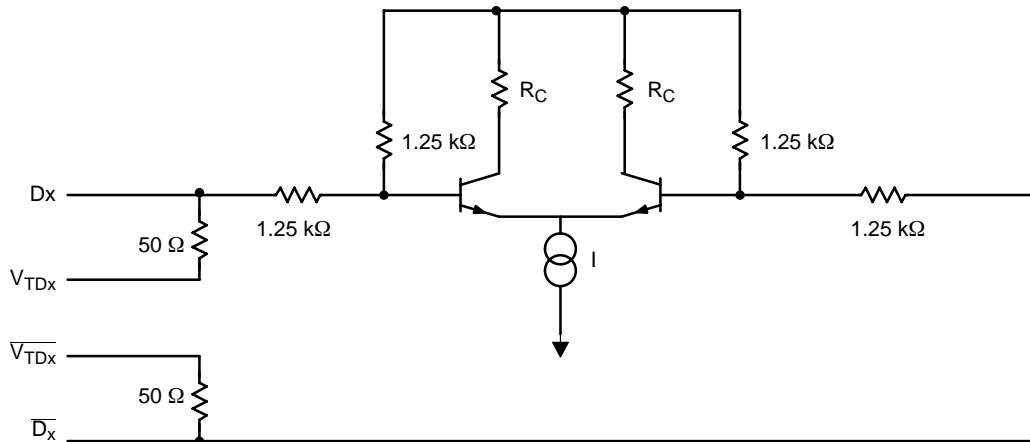

Figure 6. Input Structure

NB4N527S

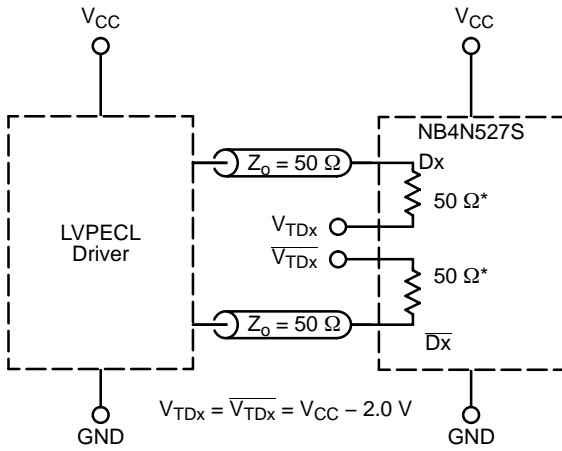

Figure 7. LVPECL Interface

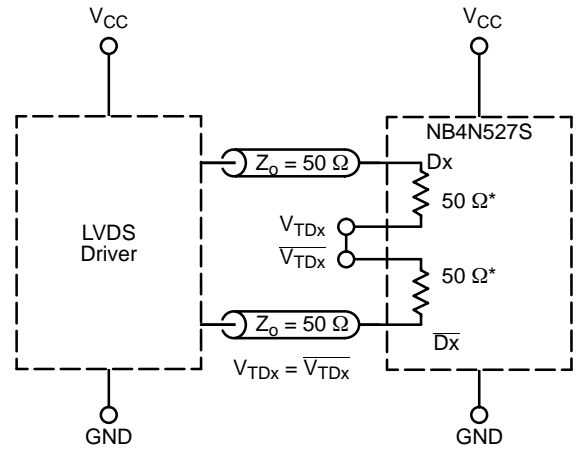

Figure 8. LVDS Interface

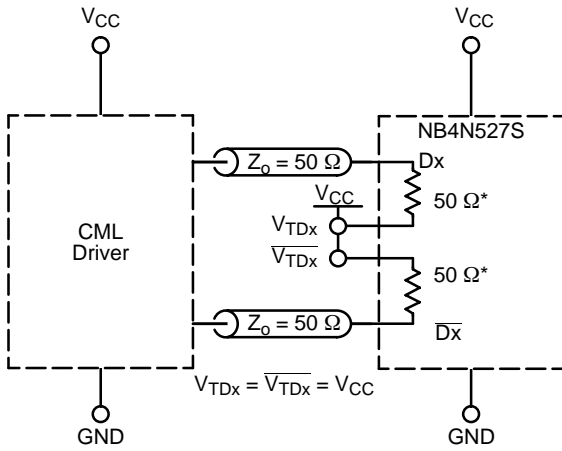

Figure 9. Standard 50 Ω Load CML Interface

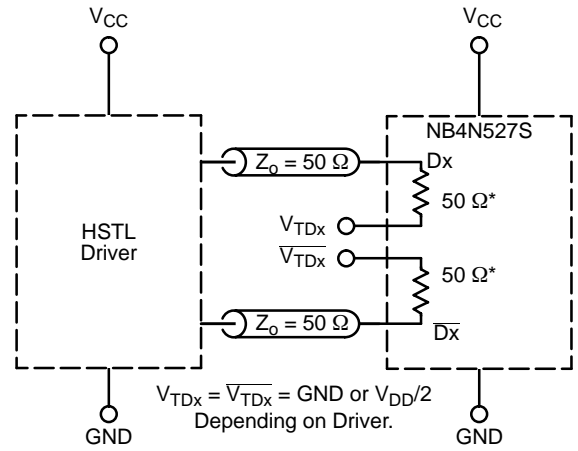

Figure 10. HSTL Interface

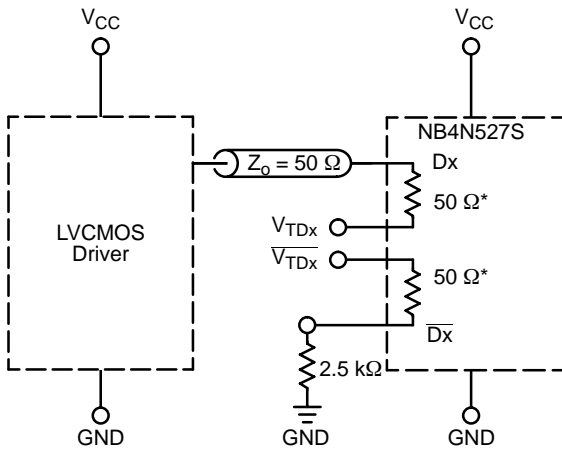

Figure 11. LVC MOS Interface

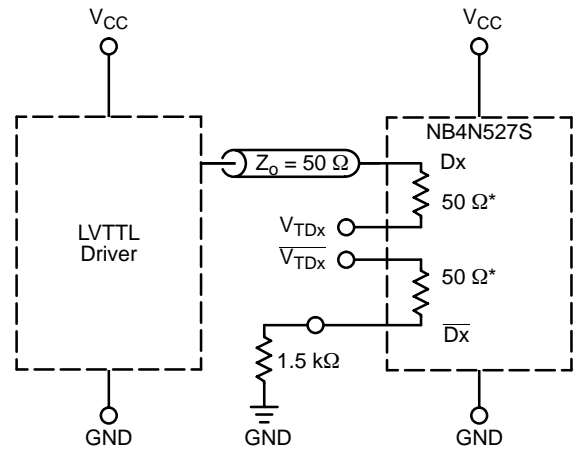

Figure 12. LVTTTL Interface

* R_{TIN} , Internal Input Termination Resistor.

NB4N527S

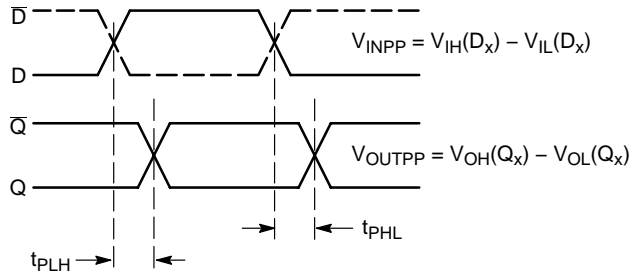

Figure 13. AC Reference Measurement

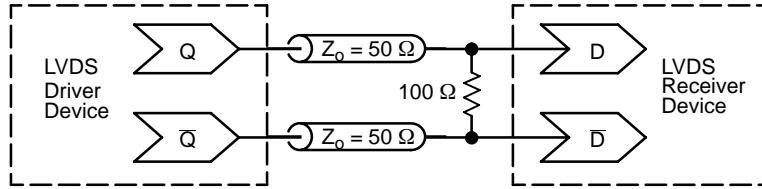

Figure 14. Typical LVDS Termination for Output Driver and Device Evaluation

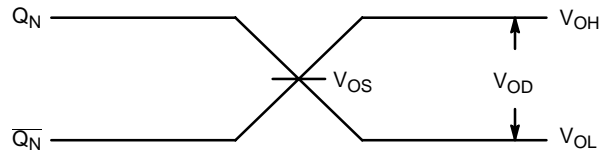

Figure 15. LVDS Output

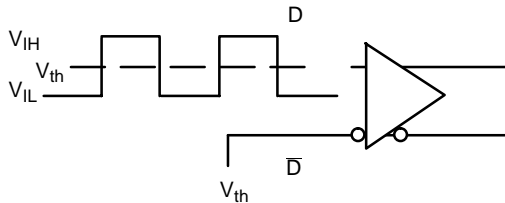

Figure 16. Differential Input Driven Single-Ended

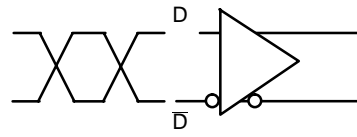

Figure 17. Differential Inputs Driven Differentially

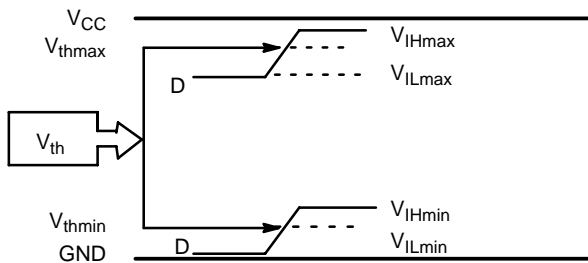

Figure 18. V_{th} Diagram

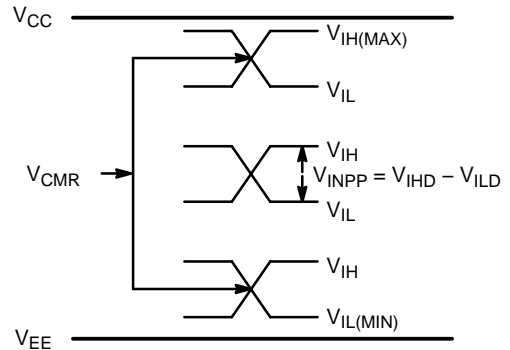

Figure 19. V_{CMR} Diagram

NB4N527S

ORDERING INFORMATION

Device	Package	Shipping†
NB4N527SMN	QFN-16	123 Units / Rail
NB4N527SMNG	QFN-16 (Pb-Free)	123 Units / Rail
NB4N527SMNR2	QFN-16	3000 / Tape & Reel
NB4N527SMNR2G	QFN-16 (Pb-Free)	3000 / Tape & Reel

†For information on tape and reel specifications, including part orientation and tape sizes, please refer to our Tape and Reel Packaging Specifications Brochure, BRD8011/D.

NB4N527S

PACKAGE DIMENSIONS

16 PIN QFN
CASE 485G-01
ISSUE C

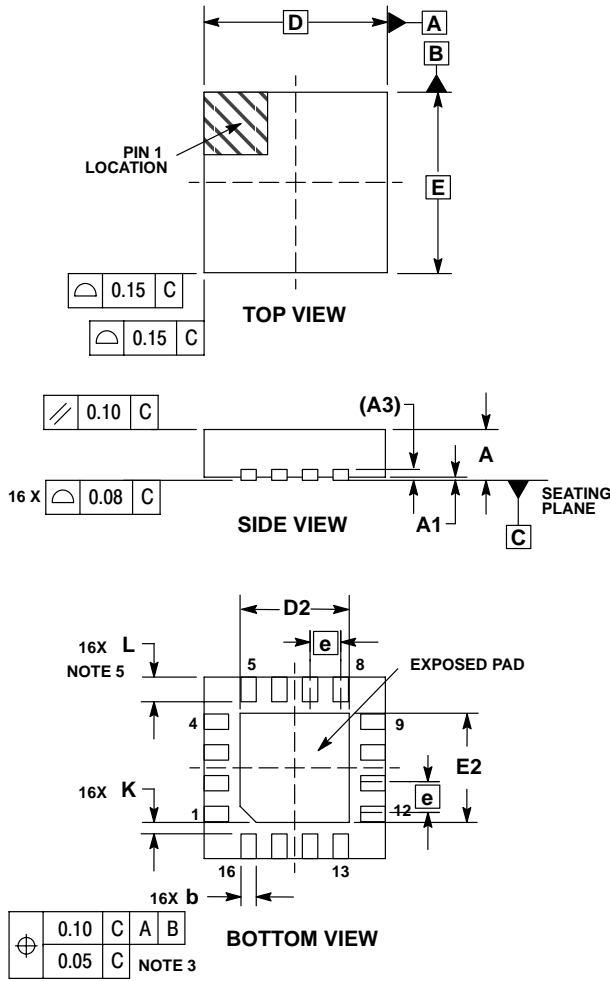

NOTES:

1. DIMENSIONING AND TOLERANCING PER ASME Y14.5M, 1994.
2. CONTROLLING DIMENSION: MILLIMETERS.
3. DIMENSION b APPLIES TO PLATED TERMINAL AND IS MEASURED BETWEEN 0.25 AND 0.30 MM FROM TERMINAL.
4. COPLANARITY APPLIES TO THE EXPOSED PAD AS WELL AS THE TERMINALS.
5. L_{max} CONDITION CAN NOT VIOLATE 0.2 MM MINIMUM SPACING BETWEEN LEAD TIP AND FLAG

MILLIMETERS		
DIM	MIN	MAX
A	0.80	1.00
A1	0.00	0.05
A3	0.20	REF
b	0.18	0.30
D	3.00	BSC
D2	1.65	1.85
E	3.00	BSC
E2	1.65	1.85
e	0.50	BSC
K	0.18	TYP
L	0.30	0.50

SOLDERING FOOTPRINT*

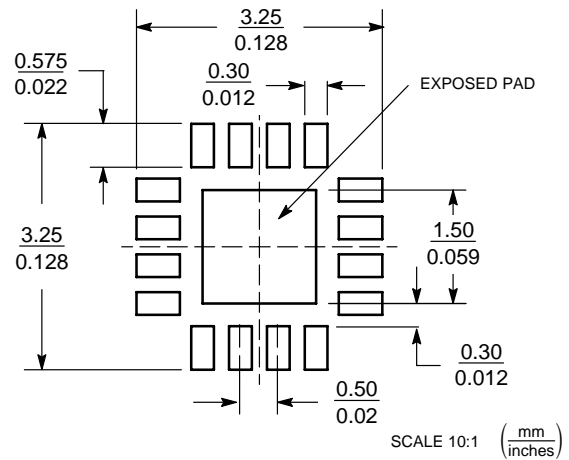

*For additional information on our Pb-Free strategy and soldering details, please download the ON Semiconductor Soldering and Mounting Techniques Reference Manual, SOLDERRM/D.

ON Semiconductor and are registered trademarks of Semiconductor Components Industries, LLC (SCILLC). SCILLC reserves the right to make changes without further notice to any products herein. SCILLC makes no warranty, representation or guarantee regarding the suitability of its products for any particular purpose, nor does SCILLC assume any liability arising out of the application or use of any product or circuit, and specifically disclaims any and all liability, including without limitation special, consequential or incidental damages. "Typical" parameters which may be provided in SCILLC data sheets and/or specifications can and do vary in different applications and actual performance may vary over time. All operating parameters, including "Typicals" must be validated for each customer application by customer's technical experts. SCILLC does not convey any license under its patent rights nor the rights of others. SCILLC products are not designed, intended, or authorized for use as components in systems intended for surgical implant into the body, or other applications intended to support or sustain life, or for any other application in which the failure of the SCILLC product could create a situation where personal injury or death may occur. Should Buyer purchase or use SCILLC products for any such unintended or unauthorized application, Buyer shall indemnify and hold SCILLC and its officers, employees, subsidiaries, affiliates, and distributors harmless against all claims, costs, damages, and expenses, and reasonable attorney fees arising out of, directly or indirectly, any claim of personal injury or death associated with such unintended or unauthorized use, even if such claim alleges that SCILLC was negligent regarding the design or manufacture of the part. SCILLC is an Equal Opportunity/Affirmative Action Employer. This literature is subject to all applicable copyright laws and is not for resale in any manner.

PUBLICATION ORDERING INFORMATION

LITERATURE FULFILLMENT:
Literature Distribution Center for ON Semiconductor
P.O. Box 5163, Denver, Colorado 80217 USA
Phone: 303-675-2175 or 800-344-3860 Toll Free USA/Canada
Fax: 303-675-2176 or 800-344-3867 Toll Free USA/Canada
Email: orderlit@onsemi.com

N. American Technical Support: 800-282-9855 Toll Free USA/Canada
Europe, Middle East and Africa Technical Support:
Phone: 421 33 790 2910
Japan Customer Focus Center
Phone: 81-3-5773-3850

ON Semiconductor Website: www.onsemi.com
Order Literature: <http://www.onsemi.com/orderlit>
For additional information, please contact your local Sales Representative