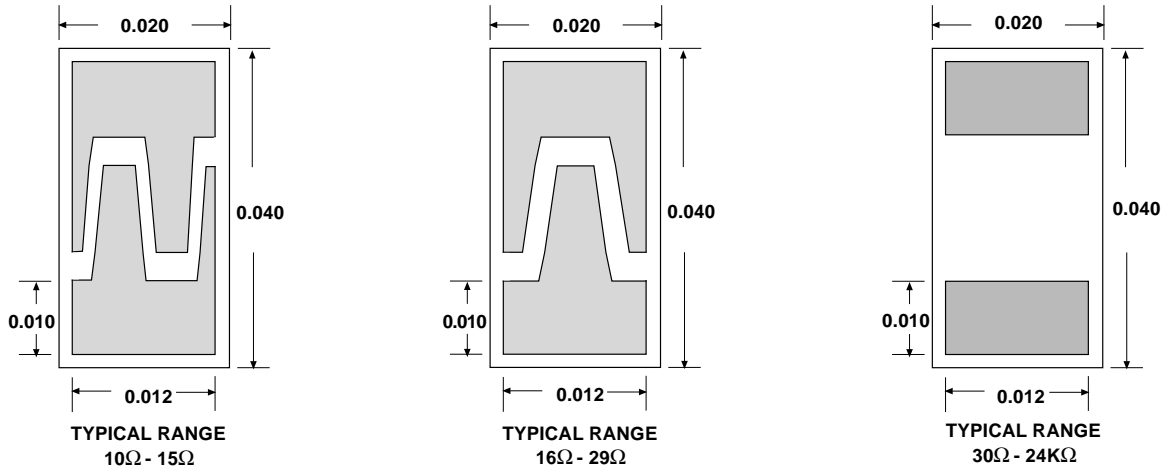

DIMENSIONS in inches

SCHEMATIC

MECHANICAL SPECIFICATIONS in inches

PARAMETER	
Chip size	0.020 x 0.040 ± 0.003 (0.5 x 1.0 ± 0.08mm)
Chip thickness	0.010 ± 0.002 (0.254 ± 0.03mm)
Chip substrate material	99.6% alumina, 2-4 μinch finish
Resistor material	Nichrome
Bonding pad size	0.010 x 0.012 (0.175 x 0.30mm)
Number of pads	2
Pad material	25kÅ minimum gold standard
Backing	None

OPTIONS: Terminations: Aluminum, Nickel solder (62/32)
 Gold back for solder die attach
 Contact Applications Engineer

ORDERING INFORMATION

Example: 100% visual, 50Ω, ± 10%, ± 100ppm/°C TCR, Gold Terminations, Resistor coated (thermal set plastic)

W	CC1	5000	B	K	E	GC
INSPECTION /PACKAGING	PRODUCT FAMILY	RESISTANCE VALUE	MULTIPLIER CODE	TOLERANCE CODE	TCR	TERMINATIONS
W = 100% visually inspected parts in matrix tray per MIL-STD-883		Use first 4 significant digits of resistance	B = 0.01 A = 0.1 0 = 1 1 = 10 2 = 100	B = 0.1%* C = 0.25%* D = 0.5% F = 1.0% G = 2.0% J = 5.0% K = 10% * Coating standard	B = ± 25ppm/°C D = ± 50ppm/°C E = ± 100ppm/°C	G = Gold S = Solder GC = Gold/Coated SC = Solder/Coated
X = Sample, commercial visually inspected parts loaded in matrix trays (4% AQL)						

NOTE: Factory will convert order number into final part number

VISHAY ELECTRO-FILMS • FRANCE +33.4.93.37.28.24 FAX: +33.4.93.37.27.31 • GERMANY +49.9287.710 FAX: +49 9287.70435 • ISRAEL +972.3.557.0945 FAX: +972.3.558.9121
 • ITALY + 39.2.300.11911 FAX: +39.2.300.11999 • JAPAN +81.42.729.0661 FAX: +81.42.729.3400 • SINGAPORE +65.788.6668 FAX: +65.788.0988
 • SWEDEN +46.8.594.70590 FAX: +46.8.594.70581 • UK +44 191 514 8237 FAX: +44 1953 457 722 • USA: (401) 738-9150 FAX: (401) 738-4389