



## 9015

Preliminary

**PNP EPITAXIAL SILICON TRANSISTOR**

### PRE-AMPLIFIER, LOW LEVEL & LOW NOISE

#### ■ FEATURES

- \* High total power dissipation. (450mW)
- \* Excellent hFE linearity.
- \* Complementary to UTC 9014

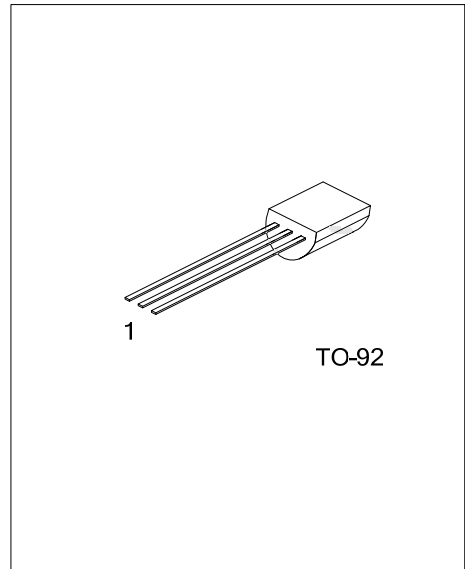

#### ■ ORDERING INFORMATION

Ordering Number		Package	Packing
Lead Free	Halogen Free		
9015L-x-T92-B	9015G-x-T92-B	TO-92	Tape Box
9015L-x-T92-K	9015G-x-T92-K	TO-92	Bulk
9015L-x-T92-T	9015G-x-T92-T	TO-92	Tape Reel

<p>9015L-x-T92-B</p>	<p>(1)Packing Type (2)Package Type (3)Rank (4)Halogen Free</p>	<p>(1) B: Tape Box, T: Tape Reel (2) T92: TO-92 (3) x: refer to Classification of hFE (4) G:Halogen Free, L: Lead Free</p>
----------------------	--	--

■ ABSOLUTE MAXIMUM RATINGS ( Ta=25°C, unless otherwise specified )

PARAMETER	SYMBOL	RATINGS	UNIT
Collector-Base Voltage	$V_{CBO}$	-50	V
Collector-Emitter Voltage	$V_{CEO}$	-45	V
Emitter-Base Voltage	$V_{EBO}$	-5	V
Collector Current	$I_C$	-100	mA
Collector Dissipation	$P_C$	450	mW
Junction Temperature	$T_J$	+150	°C
Storage Temperature	$T_{STG}$	-55~+150	°C

Note: Absolute maximum ratings are those values beyond which the device could be permanently damaged. Absolute maximum ratings are stress ratings only and functional device operation is not implied.

■ ELECTRICAL CHARACTERISTICS ( Ta=25°C, unless otherwise specified)

PARAMETER	SYMBOL	TEST CONDITIONS	MIN	TYP	MAX	UNIT
Collector-Base Breakdown Voltage	$BV_{CBO}$	$I_C = -100\mu A, I_E = 0$	-50			V
Collector-Emitter Breakdown Voltage	$BV_{CEO}$	$I_C = -1mA, I_B = 0$	-45			V
Emitter-Base Breakdown Voltage	$BV_{EBO}$	$I_E = -100\mu A, I_C = 0$	-5			V
Collector-Emitter Saturation Voltage	$V_{CE(sat)}$	$I_C = -100mA, I_B = -5mA$		-0.2	-0.7	V
Base-Emitter Saturation Voltage	$V_{BE(sat)}$	$I_C = -100mA, I_B = -5mA$		-0.82	-1.0	V
Base-Emitter On Voltage	$V_{BE(on)}$	$V_{CE} = -5V, I_C = -2mA$	-0.6	-0.65	-0.75	V
Collector Cutoff Current	$I_{CBO}$	$V_{CB} = -50V, I_E = 0$			-50	nA
Emitter Cutoff Current	$I_{EBO}$	$V_{EB} = -5V, I_C = 0$			-100	nA
DC Current Gain	$h_{FE}$	$V_{CE} = -5V, I_C = -1mA$	60	200	600	
Output Capacitance	$C_{ob}$	$V_{CB} = -10V, I_E = 0, f = 1MHz$		4.5	7.0	pF
Current Gain-Bandwidth Product	$f_T$	$V_{CE} = -5V, I_C = -10mA$	100	190		MHz
Noise Figure	NF	$V_{CE} = -5V, I_C = -0.2mA$ $f = 1KHz, R_s = 1K\Omega$		0.7	10	dB

■ CLASSIFICATION OF  $h_{FE}$

RANK	A	B	C
RANGE	60-150	100-300	200-600

UTC assumes no responsibility for equipment failures that result from using products at values that exceed, even momentarily, rated values (such as maximum ratings, operating condition ranges, or other parameters) listed in products specifications of any and all UTC products described or contained herein. UTC products are not designed for use in life support appliances, devices or systems where malfunction of these products can be reasonably expected to result in personal injury. Reproduction in whole or in part is prohibited without the prior written consent of the copyright owner. The information presented in this document does not form part of any quotation or contract, is believed to be accurate and reliable and may be changed without notice.