

MAXIM

CMOS, μ P-Compatible 8-Bit A/D Converter

MX7574/883B

1.0 SCOPE

- 1.1** This specification covers the detail requirements for an 8-bit, monolithic, CMOS multiplying analog-to-digital converter, which is processed in accordance with MIL-STD-883 and is fully compliant to paragraph 1.2.1.

It is highly recommended that this data sheet be used as a baseline for new military or aerospace source control drawings.

For typical applications and operating characteristics, consult Maxim's data books.

1.2 Part Numbers

Device	Part Number
-1	MX7574S(X)/883B
-2	MX7574T(X)883/B

1.3 Package

(X)	Package	Description
Q	Q-18	18-Pin Dual-In-Line Package (CERDIP)
E	E-20	20-Pin Ceramic Leadless Chip Carrier (LCC)
D	D-18	18-Pin Side-Brazed Ceramic Package (Ceramic SB)

Note: See *Package Information* section for package drawings and dimensions.

1.4 Absolute Maximum Ratings

($T_A = +25^\circ\text{C}$, unless otherwise noted.)

V_{DD} to AGND	0V, +7V
V_{DD} to DGND	0V, +7V
Clock Input Voltage to DGND	-0.3V, V_{DD}
Digital Input to DGND	-0.3V, V_{DD}
Digital Output Voltage to DGND	-0.3V, V_{DD}
VREF	-20V, +20V
V_{BOFS}	-20V, +20V
VAIN	-20V, +20V
Power Dissipation ($T_A = +70^\circ\text{C}$, $T_j = +150^\circ\text{C}$)	
18-Pin CERDIP (derate 10.53mW/ $^\circ\text{C}$ above $+70^\circ\text{C}$)	789mW
20-Pin LCC (derate 9.09mW/ $^\circ\text{C}$ above $+70^\circ\text{C}$)	727mW
18-Pin Ceramic SB (derate 11.11mW/ $^\circ\text{C}$ above $+70^\circ\text{C}$)	889mW
Operating Temperature Range	-55 $^\circ\text{C}$ to +125 $^\circ\text{C}$
Storage Temperature Range	-65 $^\circ\text{C}$ to +150 $^\circ\text{C}$
Lead Temperature (soldering, 10 sec)	+300 $^\circ\text{C}$

7

MAXIM

Maxim Integrated Products 7-69

Call toll free 1-800-998-8800 for free samples or literature.

CMOS, μ P-Compatible 8-Bit A/D Converter

- 1.5 Thermal Resistance** $\Theta_{JC} = 40^{\circ}\text{C/W}$ for D-18
 $\Theta_{JC} = 45^{\circ}\text{C/W}$ for Q-18
 $\Theta_{JC} = 55^{\circ}\text{C/W}$ for E-20
 $\Theta_{JA} = 90^{\circ}\text{C/W}$ for D-18
 $\Theta_{JA} = 95^{\circ}\text{C/W}$ for Q-18
 $\Theta_{JA} = 110^{\circ}\text{C/W}$ for E-20

2.0 REQUIREMENTS

- 2.1** Electrical performance characteristics are specified in Table 1 and apply over the full ambient operating temperature range, unless otherwise specified.

TABLE 1. ELECTRICAL PERFORMANCE CHARACTERISTICS (Note 1)

CHARACTERISTICS	SYMBOL	CONDITIONS	DEVICE TYPES	GROUP A SUB-GROUPS	LIMITS		UNITS
					MIN	MAX	
Resolution	RES	Guaranteed, but not tested	-1, -2		8		Bits
Relative Accuracy	RA	500kHz external clock frequency	-1	1, 2, 3	-0.75	0.75	LSB
			-2	1, 2, 3, 4	-0.5	0.5	
Differential Nonlinearity	DNL	500kHz external clock frequency	-1	1, 2, 3	-0.875	0.875	LSB
			-2	1, 2, 3, 4	-0.75	0.75	
Gain Error	AE	Gain error is measured after calibrating offset error, 500kHz external clock frequency	-1	1	-5	5	LSB
				2, 3	-6.5	6.5	
			-2	1	-3	3	
				2, 3	-4.5	4.5	
Offset Error	V_{OS}	500kHz external clock frequency	-1	1	-60	60	mV
				2, 3	-80	80	
			-2	1	-30	30	
				2, 3	-50	50	
Resistance Mismatch Between B_{OFS} and A_{IN}	RM		-1, -2	1, 2, 3	-1.5	1.5	%
Input Resistance	R_{IN}	At V_{REF}	-1, -2	1, 2, 3	5	15	k Ω
		At B_{OFS}			10	30	
		At A_{IN}			10	30	
Digital Input High Level	V_{IH}	RD, CS	-1, -2	1, 2, 3	3		V
Digital Input Low Level	V_{IL}		-1, -2	1, 2, 3	0.8		V
Digital Input Current	I_{IN}	$V_{IN} = 0V$ or V_{DD}	-1, -2	1	-1	1	μ A
				2, 3	-10	10	
Digital Input Capacitance	C_{IN}		-1, -2	4	7		pF
Clock Input High	V_{IH}		-1, -2	1, 2, 3	3		V
Clock Input Low	V_{IL}		-1, -2	1, 2, 3	0.4		V
Clock Input High Current	I_{IH}		-1, -2	1, 2, 3	-2	2	mA
Clock Input Low Current	I_{IL}		-1, -2	1	-1	1	μ A
				2, 3	-10	10	

CMOS, μ P-Compatible 8-Bit A/D Converter

MX7574/883B

TABLE 1. ELECTRICAL PERFORMANCE CHARACTERISTICS (Note 1) (continued)

CHARACTERISTICS	SYMBOL	CONDITIONS	DEVICE TYPES	GROUP A SUB-GROUPS	LIMITS		UNITS
					MIN	MAX	
Digital Output High Level	V _{OH}	I _{SOURCE} = 40 μ A	-1, -2	1, 2, 3	4		V
Digital Output Low Level	V _{OL}	I _{SINK} = 1.6mA	-1, -2	1		0.4	V
				2, 3		0.8	
Floating State Leakage Current (D7-D0)	I _{LKG}	V _{OUT} = 0V or V _{DD}	-1, -2	1	-1	1	μ A
				2, 3	-10	10	
Floating State Output Capacitance (D7-D0)	C _{OUT}		-1, -2	4		7	pF
Supply Current	I _{DD}	A _{IN} = 0V, $\overline{\text{BUSY}}$ and $\overline{\text{RD}}$ = High	-1, -2	1, 2, 3		5	mA
$\overline{\text{CS}}$ Pulse Width	t _{CS}		-1, -2	9	150		ns
$\overline{\text{RD}}$ to $\overline{\text{CS}}$ Setup Time	t _{WCS}		-1, -2	9	0		ns
$\overline{\text{CS}}$ to $\overline{\text{BUSY}}$ Propagation Delay	t _{CBPD}	BUSY load = 20pF	-1, -2	9		180	ns
		BUSY load = 100pF				200	
$\overline{\text{BUSY}}$ to $\overline{\text{RD}}$ Setup Time	t _{BSR}		-1, -2	9	0		ns
$\overline{\text{BUSY}}$ to $\overline{\text{CS}}$ Setup Time	t _{BSCS}		-1, -2	9	0		ns
Data-Valid Access Time	t _{RAD}	D7-D0, load = 100pF	-1, -2	9		400	ns
Data-Valid Hold Time	t _{RHD}		-1, -2	9		180	ns
$\overline{\text{CS}}$ to $\overline{\text{RD}}$ Hold Time	t _{RHS}		-1, -2	9		500	ns
Reset Time Requirement	t _{RESET}		-1, -2	9	3		μ s
$\overline{\text{RD}}$ to $\overline{\text{BUSY}}$	t _{WBPD}	BUSY load = 20pF	-1, -2	9		2	μ s
Conversion Time	t _{CONVERT}	2MHz external clock	-1, -2	9		15	μ s

Note 1: V_{DD} = +5V, V_{REF} = -10V, unipolar configuration, R_{CLK} = 180k Ω , C_{CLK} = 100pF unless otherwise noted.

CMOS, μ P-Compatible 8-Bit A/D Converter

MX7574/883B

3.0 QUALITY ASSURANCE

- 3.1** Sampling and inspection procedures shall be in accordance with MIL-M-38510 and, to the extent specified, with MIL-STD-883.
- 3.2** Screening shall be in accordance with Method 5004 of MIL-STD-883.
Burn-in test (Method 1015):
- (1) Test condition A, B, C, or D.
 - (2) $T_A = +125^\circ\text{C}$, minimum.
- 3.3** Quality conformance inspection shall be in accordance with Method 5005 of MIL-STD-883 including groups A, B, C, and D inspection.
Group A inspection:
- (1) Tests as specified in Table 2.
- 3.4** Groups C and D Inspections:
- a. End-point electrical parameters shall be as specified in Table 1.
 - b. Steady-state life test (Method 1005 of MIL-STD-883):
 - (1) Test condition A, B, C, or D.
 - (2) $T_A = +125^\circ\text{C}$, minimum.
 - (3) Test duration, 1000 hours, except as permitted by Method 1005 of MIL-STD-883.

TABLE 2. ELECTRICAL TEST REQUIREMENTS

MIL-STD-883 Test Requirements	Subgroups (per Method 5005, Table 1)
Interim Electrical Parameters (Method 5004)	1
Final Electrical Parameters (Method 5004)	1,* 2, 3, 9
Group A Test Requirements (Method 5005)	1, 2, 3, 4,** 9
Groups C and D End-Point Electrical Parameters (Method 5005)	1

* PDA applies to Subgroup 1 only.

**Subgroup 4 shall be tested at initial qualification and upon redesign. Sample size will be 5 units.

CMOS, μ P-Compatible 8-Bit A/D Converter

MX7574/883B

4.0 Life Test/Burn-In Circuit

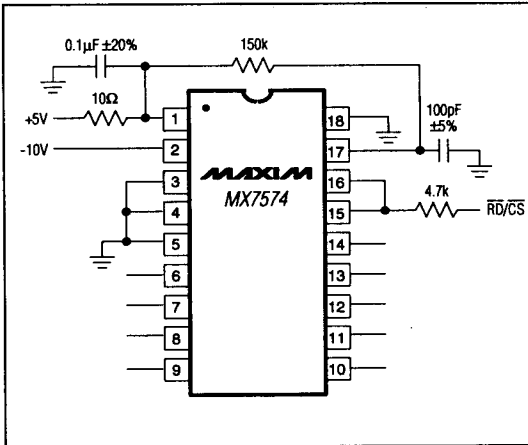

4.2 Functional Diagram

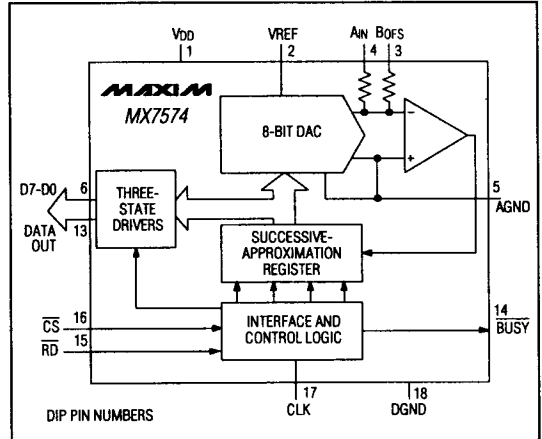

4.1 Pin Configurations

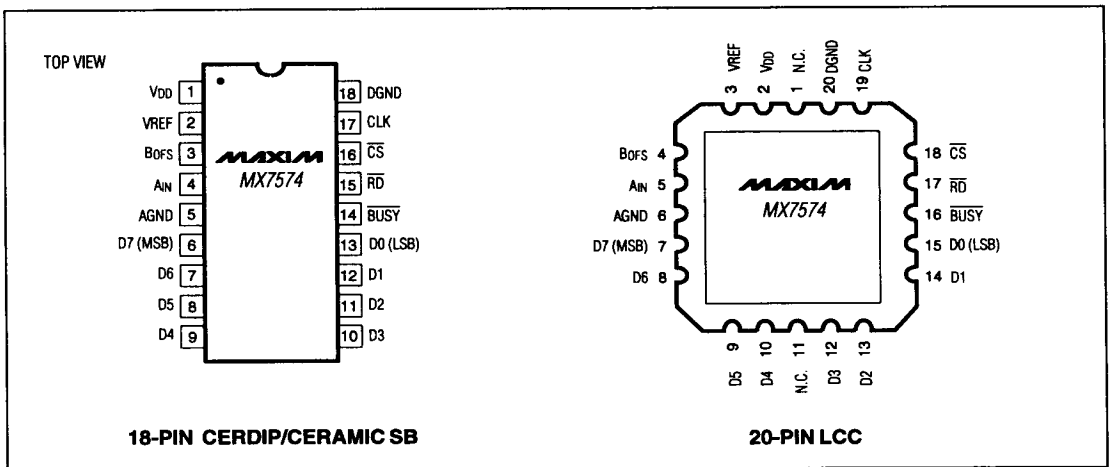

7