

LI+ BATTERY PROTECTION CIRCUIT

DESCRIPTION

SC121 is a LI+ battery protection circuit. It is suitable for protecting LI+ battery against damage from over charge, over discharge, and over current. It contains high accurate voltage detection and delay circuits.

FEATURES

- * Low supply current
- * Over-charge detect 4.28V, Over-charge release 4.10V.
- * Over-discharge detect 2.50V, Over-discharge release 2.90V.
- * Over-current detect 0.15V, Short Current detect 1.00V.
- * Overcharge/over-discharge/over-current detection delay
- * Charger detection
- * Reset resistance for over current protection
- * Wide supply voltage range
- * Small package

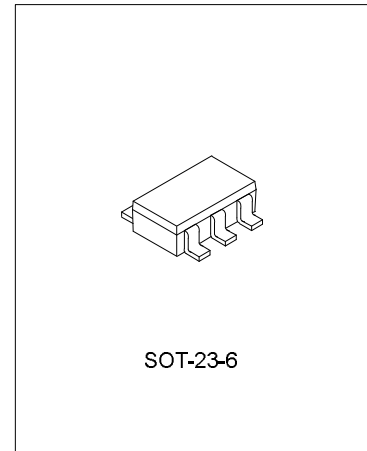

APPLICATIONS

- * Protection IC for One-Cell LI+ Battery Pack

ORDERING INFORMATION

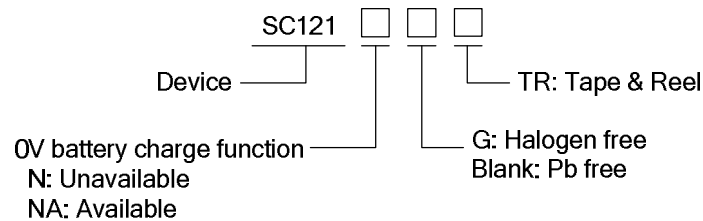

Part No.	Package	Marking	Material	Package Type
SC121NTR	SOT-23-6	121N	Pb free	Tape & Reel
SC121NATR		121NA	Pb free	Tape & Reel
SC121NGTR		121NG	Halogen free	Tape & Reel
SC121NAGTR		121NAG	Halogen free	Tape & Reel

Characteristics	Symbol	Status	Min.	Typ.	Max.	Unit
Over Current 1 Detection Voltage	VOI1		0.13	0.15	0.17	V
Over Current 2(Short Current)Detection Voltage	VOI2	VDD=3.6V	0.80	1.00	1.20	V
Over Current Reset Resistor	Rshort	VDD=3.6V	400	500	600	kΩ
Charger Detection Voltage	VCH		-0.8	-0.5	-0.2	V
Delay Time						
Over Charge Detection Delay Time	TOC	VDD=3.6V~4.4V	150	340	500	ms
Over Discharge Detection Delay Time	TOD	VDD=3.6V~2.0V	80	200	300	ms
Over Current 1 Detection Delay Time	TOI1	VDD=3.6V	5	13	20	ms
Over Current 2(Short Current)Detection Delay Time	TOI2	VDD=3.6V		5	50	μs
Other						
OC Pin Output "H" Voltage	Voh1		VDD-0.1	VDD-0.02		V
OC Pin Output "L" Voltage	Vol1			0.01	0.1	V
OD Pin Output "H" Voltage	Voh2		VDD-0.1	VDD-0.02		V
OD Pin Output "L" Voltage	Vol2			0.01	0.1	V
0 V battery charge starting charger voltage	VOCHA	SC121NA	1.55			V

PIN CONFIGURATION

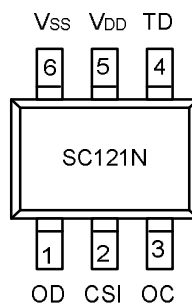

PIN DESCRIPTIONS

PIN No.	Symbol	I/O	Description
1	OD	O	FET gate connection pin for discharge control.
2	CSI	I/O	Input pin for current sense, charger detect.
3	OC	O	FET gate connection pin for charge control.
4	TD	I	Test pin for reduce delay time.
5	VDD	I	Positive power input pin.
6	VSS	I	Negative power input pin.

FUNCTION DESCRIPTIONS

Normal Status

If $V_{ODL} < V_{DD} < V_{OCU}$ and $V_{CH} < V_{CSI} < V_{OI1}$, M1 and M2 are both turned on (refer to Typical Application Circuits). The charging and discharging processes can be operated normally.

Overcharge Detection

When enter charging from normal status, the battery voltage can be detected from VDD. When the battery is in overcharge status, VDD is larger than V_{OCU} over a delay time of T_{OC}, M2 is to be turned off.

Release of Overcharge Status

There are two ways to return to normal status from overcharge status.

- If the battery is self discharging and $V_{DD} < V_{OCR}$ occurs, M2 is to be turned on and back to normal status.
- Remove the charger and connected to a load. If $V_{OCR} < V_{DD} < V_{OCU}$ and $V_{CSI} > V_{OI1}$ occurs, M2 is to be turned on and back to normal status.

Over discharge Detection

When enter discharging from normal status, the battery voltage can be detected from VDD. When the battery is in over discharge status, VDD is smaller than V_{ODL} over a delay time of T_{OD}; M1 is to be turned off. In the meanwhile, CSI is pulled to VDD by way of internal resistor R_{CSID}. If $V_{CSI} > V_{OI2}$, the protection IC enters into Power-down mode. (Its current consumption is lower than 0.3μA).

Release of Power-down mode

A charger is connected while the battery remains in Power-down mode. If $V_{CH} < V_{CSI} < V_{OI2}$ and $V_{DD} < V_{ODR}$ occur, M1 is still off but it releases Power-down mode. If $V_{DD} > V_{ODR}$ occurs, M1 is to be turned on and back to normal status.

Charger Detection

If a charger is connected to the battery remained in Power-down mode, the voltages will become $V_{CSI} < V_{CH}$ and $V_{DD} > V_{ODL}$. M1 is to be turned on and back to normal status.

Abnormal Charging Status

If a charger is connected to the battery in normal status, $V_{CSI} < V_{CH}$ occurs over a delay time longer than T_{OC}, M2 is to be turned off.

Over Current/Short Current Detection

When the discharging current is too large during discharging under normal status and the voltage detected from CSI is larger than V_{OIX} (V_{IO1} or V_{IO2}) for over a certain delay time T_{OIX} (T_{IO1} or T_{IO2}), it means the over current/short current status occurred. M1 is turned off. CSI is pulled to VSS by way of an internal resistor R_{CSIS}.

Release of Over Current/Short Current Status

While the protection IC remains in Over Current/Short Current status and load is removed or the impedance between V_{BAT+} and V_{BAT-} is larger than 500KΩ and $V_{CSI} < V_{OI1}$, M1 is to be turned on and back to normal status.

Note: when a battery is connected to a protection IC for the first time, the IC may not enter the normal status (not dischargeable status). If this occurs, set the CSI pin voltage equal to the VSS voltage (short the CSI and VSS pins or connect a charger) to enter the normal status.

TIMING DIAGRAM

Overcharge Status → Self Discharging → Normal Status

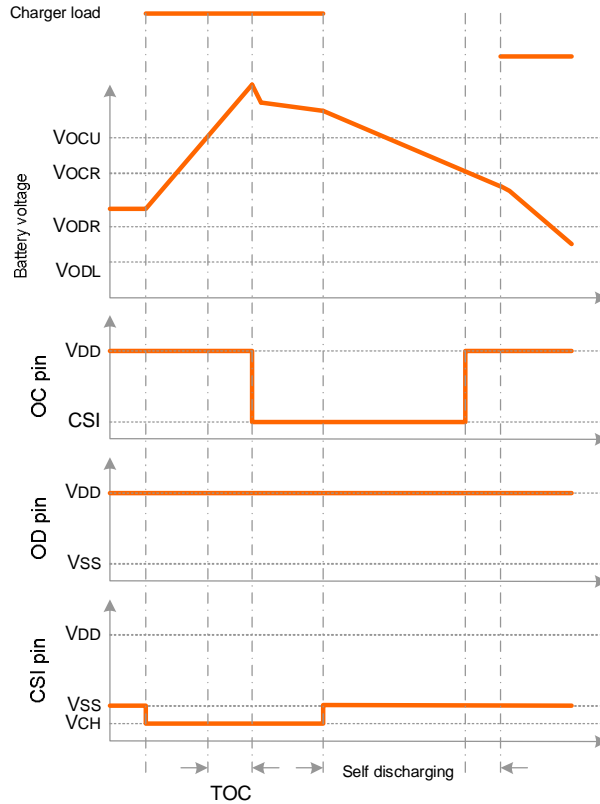

Overcharge Status → Load Discharging → Normal Status

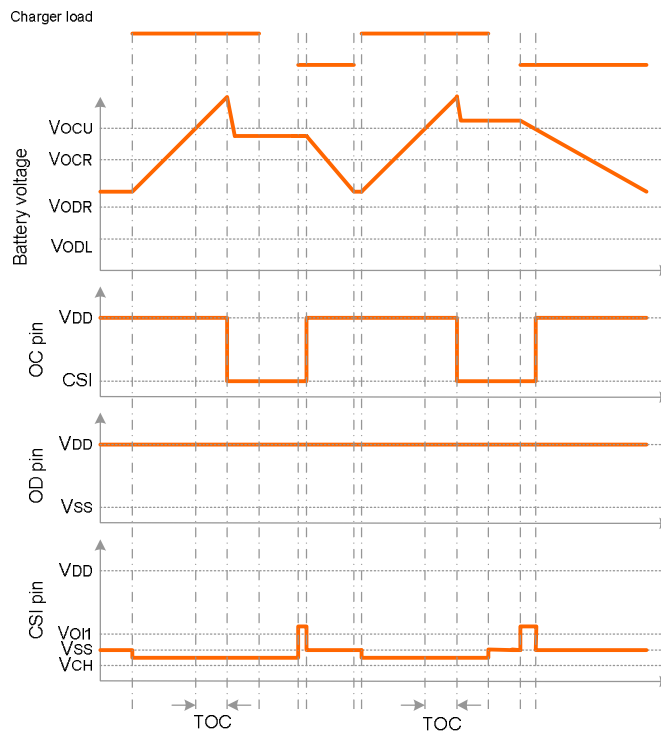

Overcharge Status→Charging By Charger→Normal Status

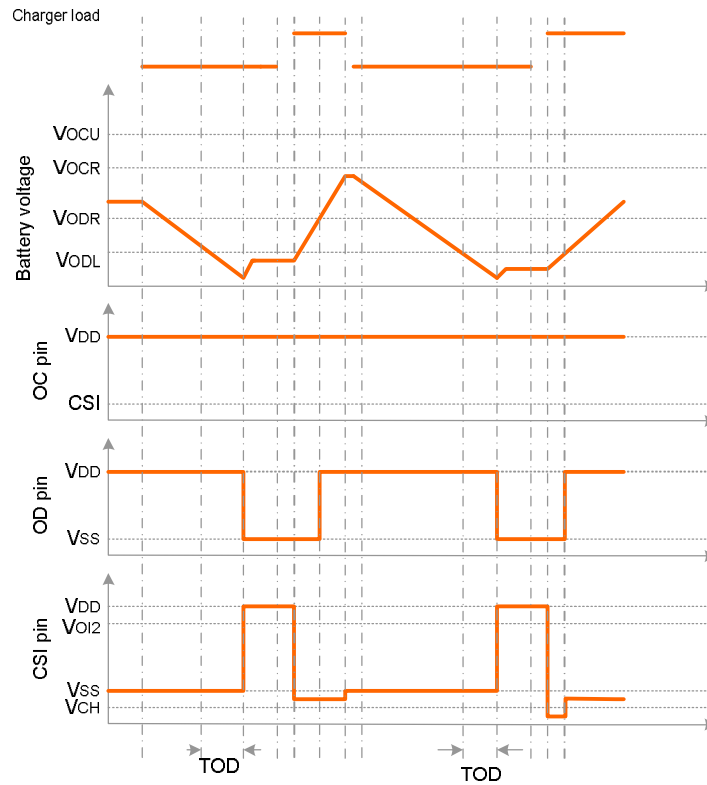

Overcharge Status→Abnormal Status→Normal Status

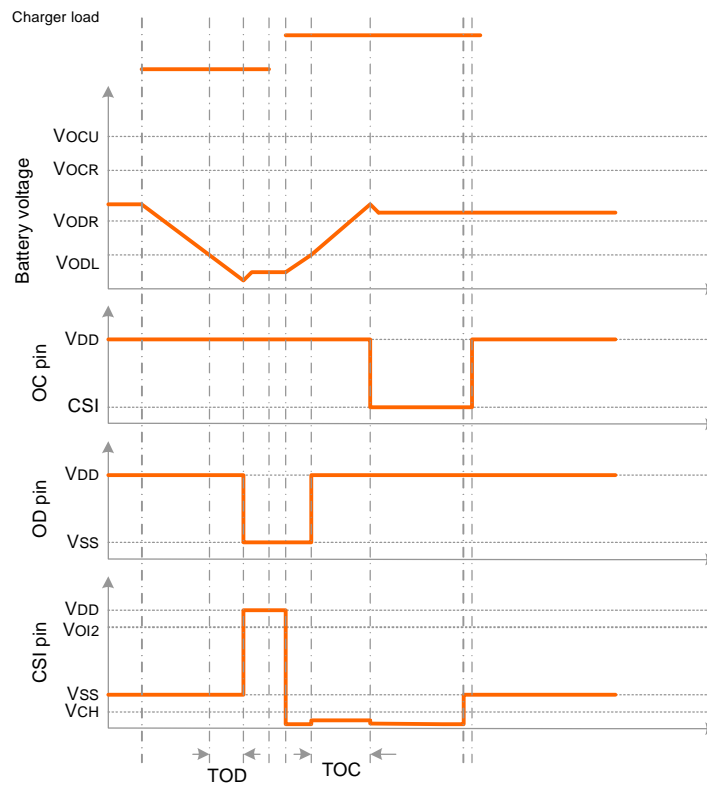

Over Current Status→Normal Status

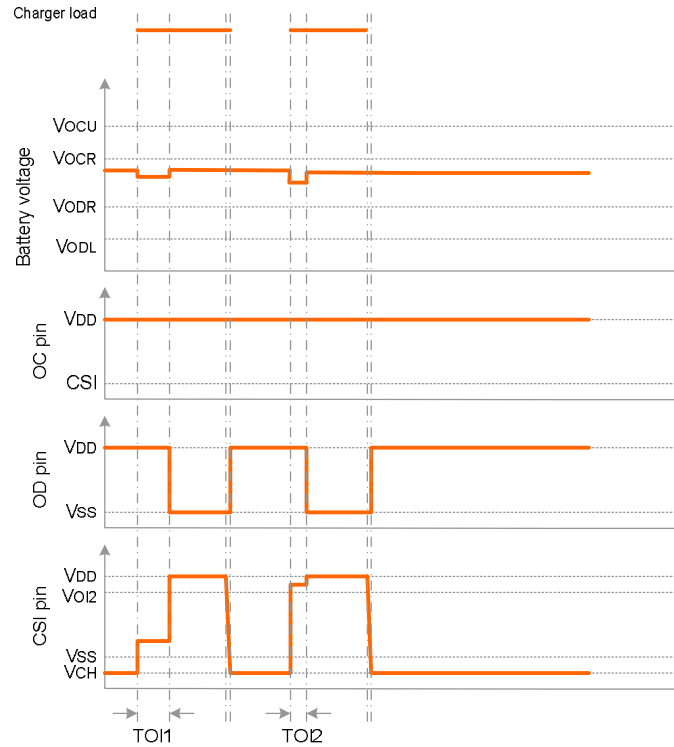

STATE DIAGRAM OF OPERATION

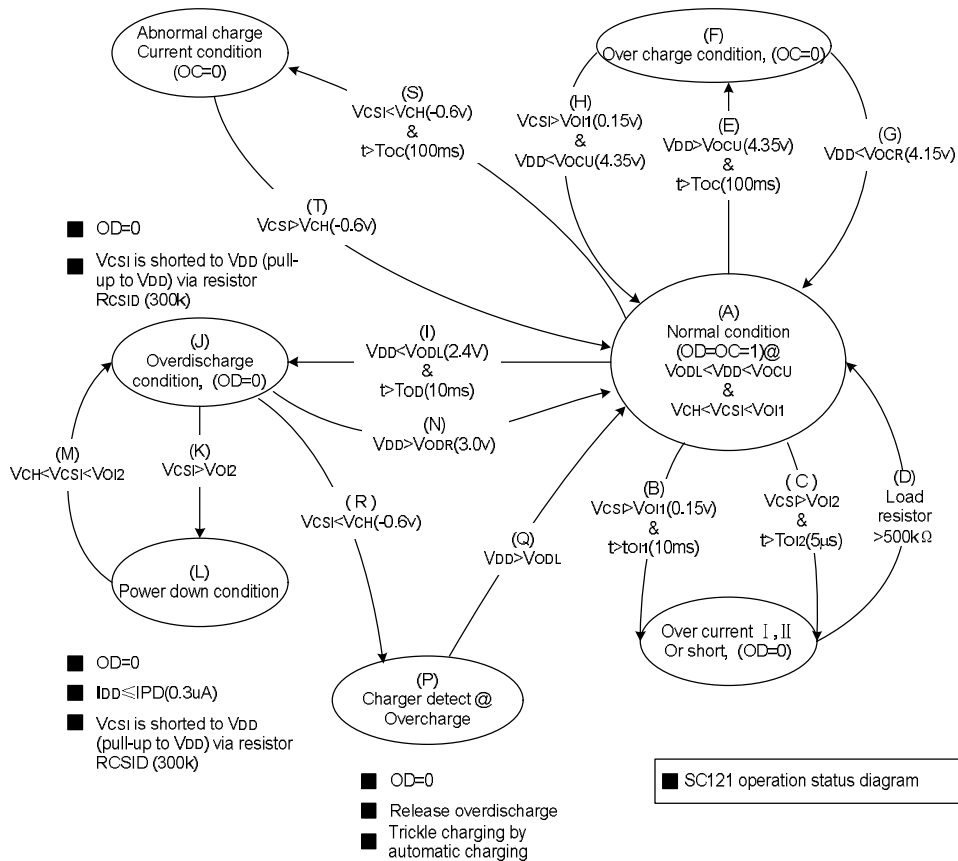

TYPICAL APPLICATION CIRCUITS

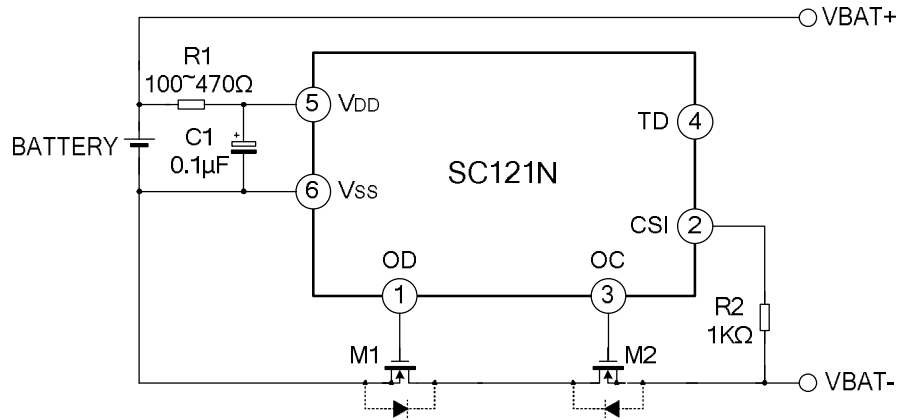

Note: The circuit and parameters are reference only, please set the parameters of the real application circuit based on the real test.

PACKAGE OUTLINE

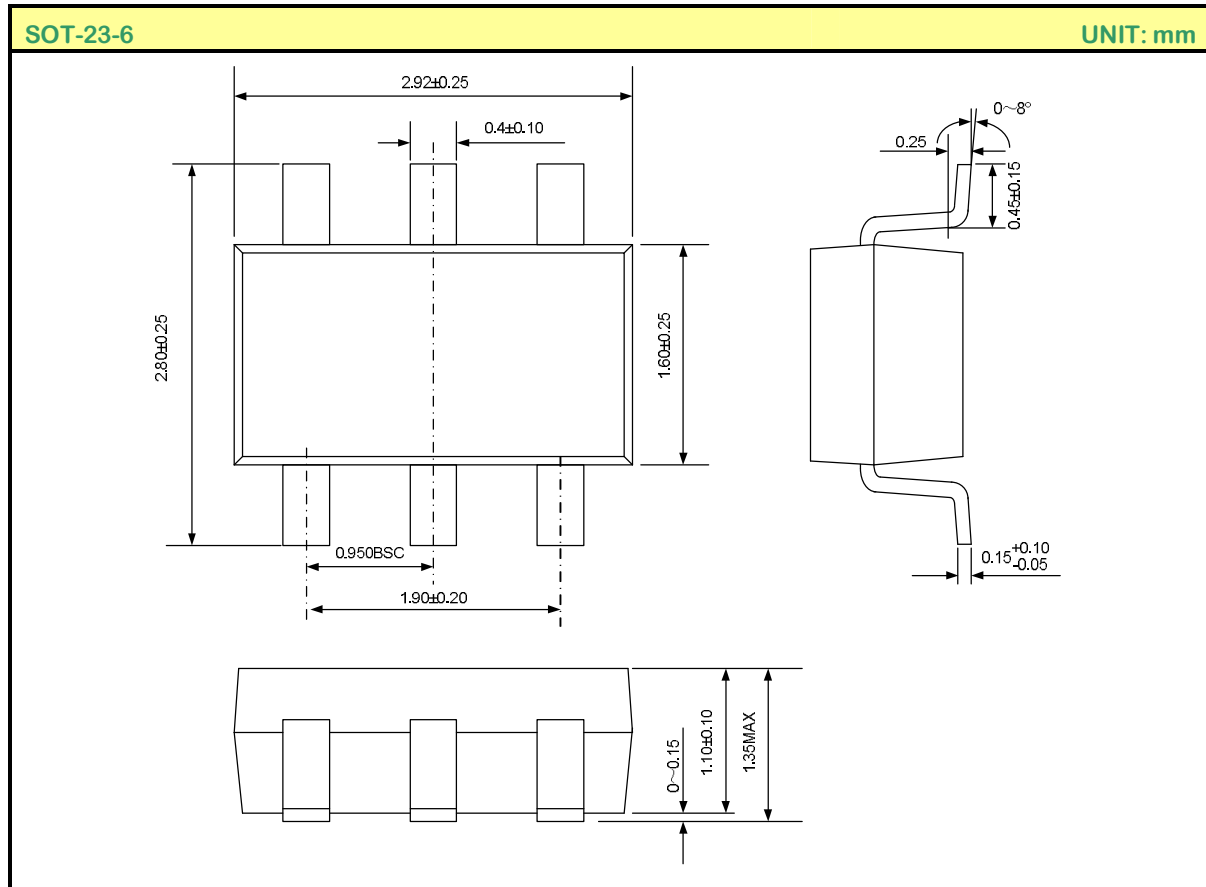

HANDLING MOS DEVICES:

Electrostatic charges can exist in many things. All of our MOS devices are internally protected against electrostatic discharge but they can be damaged if the following precautions are not taken:

- Persons at a work bench should be earthed via a wrist strap.
- Equipment cases should be earthed.
- All tools used during assembly, including soldering tools and solder baths, must be earthed.
- MOS devices should be packed for dispatch in antistatic/conductive containers.

Disclaimer:

- Silan reserves the right to make changes to the information herein for the improvement of the design and performance without further notice!
- All semiconductor products malfunction or fail with some probability under special conditions. When using Silan products in system design or complete machine manufacturing, it is the responsibility of the buyer to comply with the safety standards strictly and take essential measures to avoid situations in which a malfunction or failure of such Silan products could cause loss of body injury or damage to property.
- Silan will supply the best possible product for customers!