

# PNOZ X2/2.1

Standard Unit

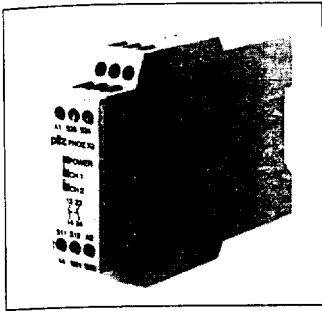

**PICONTROL**  
Emergency Stop Unit and Safety Gate Monitor to VDE 0113 Pt 1 (06.93) and EN 60204-1: 1992.

### Order Reference

**PNOZ X2**  
Voltage Part Number  
24 VDC/AC 774 303

**PNOZ X2.1**  
Voltage Part Number  
24 VDC/AC 774 306

### Special Features

- Circuit is redundant with built-in self-monitoring
- The safety function remains effective in the case of component failure
- The correct opening and closing of the safety function relays is tested automatically with each on-off cycle
- Each AC unit can also be operated with 24 VDC
- No galvanic separation.

### Unit Classification

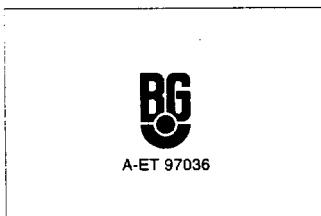

599-748  
599-750

### Description

- 22.5 mm S-95 Housing, DIN-Rail Mounting
- Relay outputs, positive-guided: 2 safety contacts (N/O)
- Connection :
  - emergency stop button or safety gate limit switch
  - reset button
- PNOZ X2: monitored reset button
- PNOZ X2.1: automatic reset possible
- Detects shorts across the input contacts
- Increase in the number of contacts via external contactors/ relays possible
- LED status indicators for channel 1 and 2 and operating voltage.

### Electronic Fuse

In the event of shorts across the contacts or an internal short-circuit, an electronic fuse causes the output relay to de-energise and protects the unit from damage. The safety release comes into effect with fault currents of  $\geq 300$  mA.

\* To avoid contact welding, a fuse (4 A slow / 6.3 A quick) must be connected externally.

### Internal Wiring Diagram

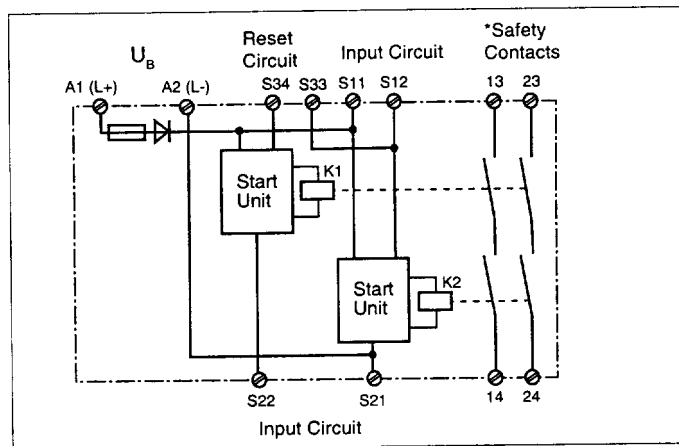

### Technical Details, PNOZ X2/2.1 (for general technical details see appendix)

Operating Voltage $U_B$	24 V AC/DC
Power Consumption by $U_B$	Approx. 2 W/2 VA
Relay Contacts	2 safety contacts (N/O); AgSnO <sub>2</sub>
Switching Capability to	
DIN EN 60 947-4-1	AC1: 250 V/6 A/1500 VA, DC1: 24 V/4 A/100 W
DIN EN 60 947-5-1	AC15: 230 V/5 A; DC13: 24 V/1.5 A
Delay-on Energisation	Auto. reset: max. 150 ms, manual reset: max.100 ms
Delay-on De-energisation K1/K2	Input circuit, one channel: max.100 ms Input circuit, two channel: max. 30 ms
Recovery Time	$\geq 1$ s
Waiting Time for PNOZ X2	Time between applying $U_B$ and closing the reset button: min. 1 s
Voltage/Current at S11, S12, S21, S22	24 V DC/25 mA
Max. Supply Interruption before De-energisation	Max. 10 ms
Operating Temperature	-10 to +55 °C
Airgap Creepage	DIN VDE 0110 part 2 para. 8, 4 kV/3
Contact Fuse Protection	6.3 A quick or 4 A slow (VDE 0660 Pt.200, DIN EN 60947)
Protection	Mounting IP 54, Housing IP 40, Terminals IP 20
Max. cross section of external conductors	2 x 1.5 mm <sup>2</sup> or 1 x 2.5 mm <sup>2</sup>
Dimensions (H x W x D)	87 x 22.5 x 121 mm
Weight	220 g

## External Wiring

### Example 1

If the emergency stop is wired through 1 channel it meets the requirements of EN 60204; but does not have redundant operation in the emergency stop circuit. Earth faults in the emergency stop circuit are detected.

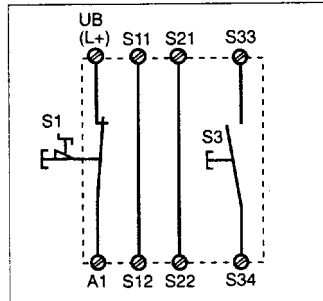

### Example 2

If the emergency stop is wired through 2 channels it will also monitor any faults in the emergency stop circuit. Earth faults in the emergency stop circuit and shorts between the emergency stop buttons are detected.

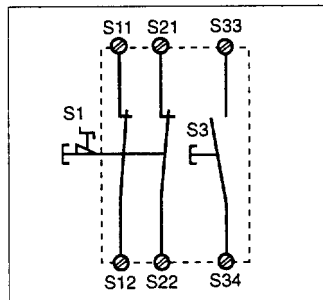

### Example 3

Only with PNOZ X2.1: 2 channel emergency stop circuit as in example 2, but with automatic reset.

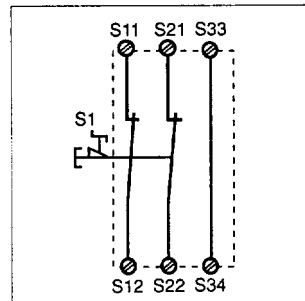

### Example 4

2 channel safety gate through 2 forced-contact limit switches, with position monitoring.

Possible application:

For safety purposes - higher degree of safety when accessing machinery. Safety interlocking ensures that no dangerous machine movements occur.

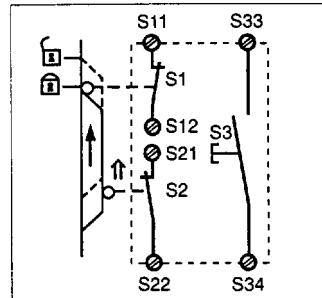

### Feedback Control Loop

If required the number of output contacts on the PNOZ X2/2.1 can be increased by using external relays with positive-guided contacts (>5 A).

The function of the external relays may be monitored by connecting N/C contacts in series to the reset circuit.

The use of 1 or 2 channel drive depends on the risk level of your machine.

**Please Note:** The diagram below only shows an example for the PNOZ X2.1.

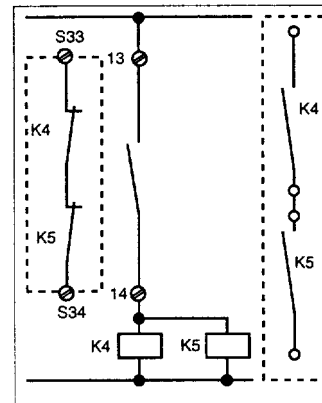

 = Gate unlocked

 = Gate locked

 = Switch activated

S1/S2: Emergency stop or safety gate switches

S3: Reset button