

74LCX374

Low Voltage Octal D-Type Flip-Flop with 5V Tolerant Inputs and Outputs

Features

- 5V tolerant inputs and outputs
- 2.3V–3.6V V_{CC} specifications provided
- 8.5ns t_{PD} max ($V_{CC} = 3.3V$), 10 μ A I_{CC} max
- Power-down high impedance inputs and outputs
- Supports live insertion/withdrawal¹
- $\pm 24mA$ output drive ($V_{CC} = 3.0V$)
- Implements patented noise/EMI reduction circuitry
- Latch-up performance exceeds JEDEC 78 conditions
- ESD performance
 - Human Body Model > 2000V
 - Machine Model > 200V
- Leadless Pb-Free DQFN package

General Description

The LCX374 consists of eight D-type flip-flops featuring separate D-type inputs for each flip-flop and 3-STATE outputs for bus-oriented applications. A buffered clock (CP) and Output Enable (\overline{OE}) are common to all flip-flops. The LCX374 is designed for low voltage applications with capability of interfacing to a 5V signal environment.

The LCX374 is fabricated with an advanced CMOS technology to achieve high speed operation while maintaining CMOS low power dissipation.

Ordering Information

Order Number	Package Number	Package Description
74LCX374WM	M20B	20-Lead Small Outline Integrated Circuit (SOIC), JEDEC MS-013, 0.300" Wide
74LCX374SJ	M20D	20-Lead Small Outline Package (SOP), EIAJ TYPE II, 5.3mm Wide
74LCX374BQX ²	MLP020B	Pb-Free 20-Terminal Depopulated Quad Very-Thin Flat Pack No Leads (DQFN), JEDEC MO-241, 2.5 x 4.5mm
74LCX374MSA	MSA20	20-Lead Shrink Small Outline Package (SSOP), JEDEC MO-150, 5.3mm Wide
74LCX374MTC	MTC20	20-Lead Thin Shrink Small Outline Package (TSSOP), JEDEC MO-153, 4.4mm Wide
74LCX374MTCX_NL ³	MTC20	Pb-Free 20-Lead Thin Shrink Small Outline Package (TSSOP), JEDEC MO-153, 4.4mm Wide

Devices also available in Tape and Reel. Specify by appending suffix letter "X" to the ordering code.
Pb-Free package per JEDEC J-STD-020B.

Notes:

1. To ensure the high impedance state during power up or down, \overline{OE} should be tied to V_{CC} through a pull-up resistor: the minimum value of the resistor is determined by the current-sourcing capability of the driver.
2. DQFN package available in Tape and Reel only.
3. "_NL" indicates Pb-Free package (per JEDEC J-STD-020B). Device available in Tape and Reel only.

Logic Symbol

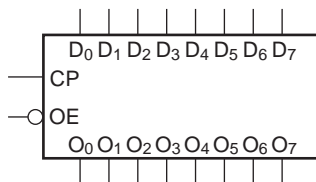

Pin Descriptions

Pin Names	Description
D ₀ -D ₇	Data Inputs
CP	Clock Pulse Input
\overline{OE}	Output Enable Input
O ₀ -O ₇	3-STATE Outputs

Connection Diagrams

Pin Assignments for SOIC, SOP, SSOP, TSSOP

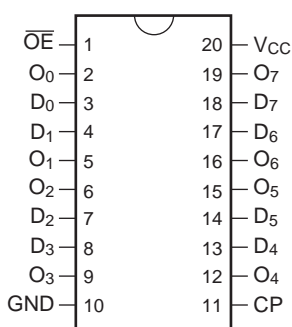

Pad Assignments for DQFN

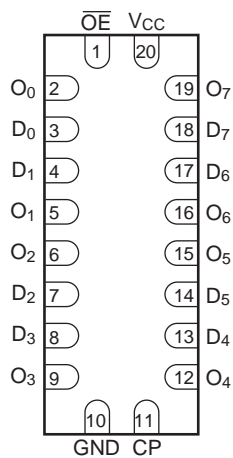

(Top View)

Truth Table

Inputs			Outputs
D _n	CP	\overline{OE}	O _n
H		L	H
L		L	L
X	L	L	O ₀
X	X	H	Z

H = HIGH Voltage Level
 L = LOW Voltage Level
 X = Immaterial
 Z = High Impedance
 = LOW-to-HIGH Transition
 O₀ = Previous O₀ before HIGH-to-LOW of CP

Functional Description

The LCX374 consists of eight edge-triggered flip-flops with individual D-type inputs and 3-STATE true outputs. The buffered clock and buffered Output Enable are common to all flip-flops. The eight flip-flops will store the state of their individual D inputs that meet the setup and hold time requirements on the LOW-to-HIGH Clock (CP) transition. With the Output Enable (\overline{OE}) LOW, the contents of the eight flip-flops are available at the outputs. When the \overline{OE} is HIGH, the outputs go to the high impedance state. Operation of the \overline{OE} input does not affect the state of the flip-flops.

Logic Diagram

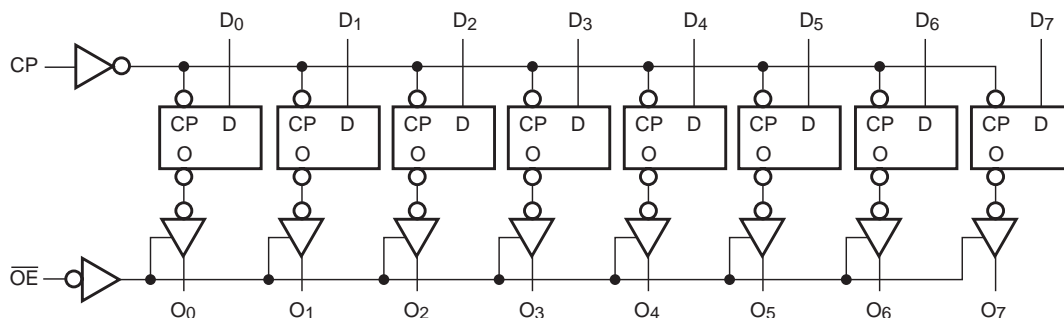

Please note that this diagram is provided only for the understanding of logic operations and should not be used to estimate propagation delays.

Absolute Maximum Ratings

The Absolute Maximum Ratings are those values beyond which the safety of the device cannot be guaranteed. The device should not be operated at these limits. The parametric values defined in the Electrical Characteristics tables are not guaranteed at the Absolute Maximum Ratings. The “Recommended Operating Conditions” table will define the conditions for actual device operation.

Symbol	Parameter	Conditions	Value	Units
V_{CC}	Supply Voltage		-0.5 to +7.0	V
V_I	DC Input Voltage		-0.5 to +7.0	V
V_O	DC Output Voltage	Output in 3-STATE	-0.5 to +7.0	V
		Output in HIGH or LOW State ⁴	-0.5 to $V_{CC} + 0.5$	
I_{IK}	DC Input Diode Current	$V_I < GND$	-50	mA
I_{OK}	DC Output Diode Current	$V_O < GND$	-50	mA
		$V_O > V_{CC}$	+50	
I_O	DC Output Source/Sink Current		± 50	mA
I_{CC}	DC Supply Current per Supply Pin		± 100	mA
I_{GND}	DC Ground Current per Ground Pin		± 100	mA
T_{STG}	Storage Temperature		-65 to +150	°C

Recommended Operating Conditions⁵

Symbol	Parameter	Conditions	Min.	Max.	Units
V_{CC}	Supply Voltage	Operating	2.0	3.6	V
		Data Retention	1.5	3.6	
V_I	Input Voltage		0	5.5	V
V_O	Output Voltage	HIGH or LOW State	0	V_{CC}	V
		3-STATE	0	5.5	
I_{OH}/I_{OL}	Output Current	$V_{CC} = 3.0V - 3.6V$		± 24	mA
		$V_{CC} = 2.7V - 3.0V$		± 12	
		$V_{CC} = 2.3V - 2.7V$		± 8	
T_A	Free-Air Operating Temperature		-40	85	°C
$\Delta t/\Delta V$	Input Edge Rate	$V_{IN} = 0.8V - 2.0V, V_{CC} = 3.0V$	0	10	ns/V

Notes:

- I_O Absolute Maximum Rating must be observed.
- Unused inputs or I/Os must be held HIGH or LOW. They may not float.

DC Electrical Characteristics

Symbol	Parameter	Conditions	V _{CC} (V)	T _A = -40°C to +85°C		Units
				Min.	Max.	
V _{IH}	HIGH Level Input Voltage		2.3 – 2.7	1.7		V
			2.7 – 3.6	2.0		
V _{IL}	LOW Level Input Voltage		2.3 – 2.7		0.7	V
			2.7 – 3.6		0.8	
V _{OH}	HIGH Level Output Voltage	I _{OH} = -100μA	2.3 – 3.6	V _{CC} - 0.2		V
		I _{OH} = -8mA	2.3	1.8		
		I _{OH} = -12mA	2.7	2.2		
		I _{OH} = -18mA	3.0	2.4		
		I _{OH} = -24mA	3.0	2.2		
V _{OL}	LOW Level Output Voltage	I _{OL} = 100μA	2.3 – 3.6		0.2	V
		I _{OL} = 8mA	2.3		0.6	
		I _{OL} = 12mA	2.7		0.4	
		I _{OL} = 16mA	3.0		0.4	
		I _{OL} = 24mA	3.0		0.55	
I _I	Input Leakage Current	0 ≤ V _I ≤ 5.5V	2.3 – 3.6		±5.0	μA
I _{OZ}	3-STATE Output Leakage	0 ≤ V _O ≤ 5.5V, V _I = V _{IH} or V _{IL}	2.3 – 3.6		±5.0	μA
I _{OFF}	Power-Off Leakage Current	V _I or V _O = 5.5V	0		10	μA
I _{CC}	Quiescent Supply Current	V _I = V _{CC} or GND	2.3 – 3.6		10	μA
		3.6V ≤ V _I , V _O ≤ 5.5V ⁶	2.3 – 3.6		±10	
ΔI _{CC}	Increase in I _{CC} per Input	V _{IH} = V _{CC} - 0.6V	2.3 – 3.6		500	μA

AC Electrical Characteristics

Symbol	Parameter	T _A = -40°C to +85°C, R _L = 500 Ω						Units
		V _{CC} = 3.3V ± 0.3V		V _{CC} = 2.7V		V _{CC} = 2.5 ± 0.2		
		C _L = 50pF		C _L = 50pF		C _L = 30pF		
		Min.	Max.	Min.	Max.	Min.	Max.	
f _{MAX}	Maximum Clock Frequency	150		150		150		MHz
t _{PHL} , t _{PLH}	Propagation Delay CP to O _n	1.5	8.5	1.5	9.5	1.5	10.5	ns
t _{PZL} , t _{PZH}	Output Enable Time	1.5	8.5	1.5	9.5	1.5	10.5	ns
t _{PLZ} , t _{PHZ}	Output Disable Time	1.5	7.5	1.5	8.5	1.5	9.0	ns
t _S	Setup Time	2.5		2.5		4.0		ns
t _H	Hold Time	1.5		1.5		2.0		ns
t _W	Pulse Width	3.3		3.3		4.0		ns
t _{OSHL} , t _{OSLH}	Output to Output Skew ⁷		1.0					ns

Notes:

6. Outputs disabled or 3-STATE only.

7. Skew is defined as the absolute value of the difference between the actual propagation delay for any two separate outputs of the same device. The specification applies to any outputs switching in the same direction, either HIGH-to-LOW (t_{OSHL}) or LOW-to-HIGH (t_{OSLH}).

Dynamic Switching Characteristics

Symbol	Parameter	Conditions	V _{CC} (V)	T _A = 25°C	
				Typical	Units
V _{OLP}	Quiet Output Dynamic Peak V _{OL}	C _L = 50pF, V _{IH} = 3.3V, V _{IL} = 0V	3.3	0.8	V
		C _L = 30pF, V _{IH} = 2.5V, V _{IL} = 0V	2.5	0.6	
V _{OLV}	Quiet Output Dynamic Valley V _{OL}	C _L = 50pF, V _{IH} = 3.3V, V _{IL} = 0V	3.3	-0.8	V
		C _L = 30pF, V _{IH} = 2.5V, V _{IL} = 0V	2.5	-0.6	

Capacitance

Symbol	Parameter	Conditions	Typical	Units
C _{IN}	Input Capacitance	V _{CC} = Open, V _I = 0V or V _{CC}	7	pF
C _{OUT}	Output Capacitance	V _{CC} = 3.3V, V _I = 0V or V _{CC}	8	pF
C _{PD}	Power Dissipation Capacitance	V _{CC} = 3.3V, V _I = 0V or V _{CC} , f = 10 MHz	25	pF

AC Loading and Waveforms (Generic for LCX Family)

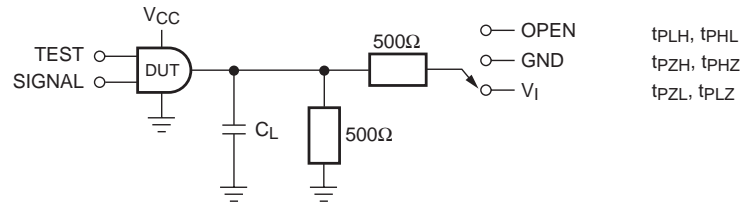

Figure 1. AC Test Circuit (C_L includes probe and jig capacitance)

Test	Switch
t_{PLH} , t_{PHL}	Open
t_{PZL} , t_{PLZ}	6V at $V_{CC} = 3.3 \pm 0.3V$ $V_{CC} \times 2$ at $V_{CC} = 2.5 \pm 0.2V$
t_{PZH} , t_{PHZ}	GND

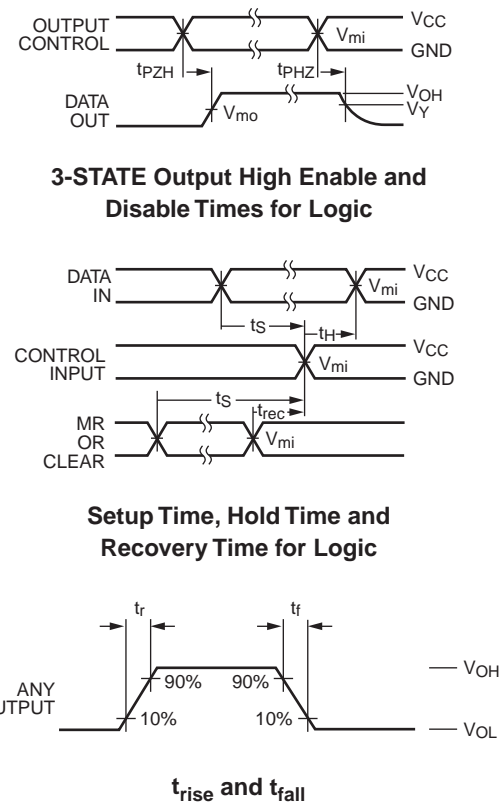
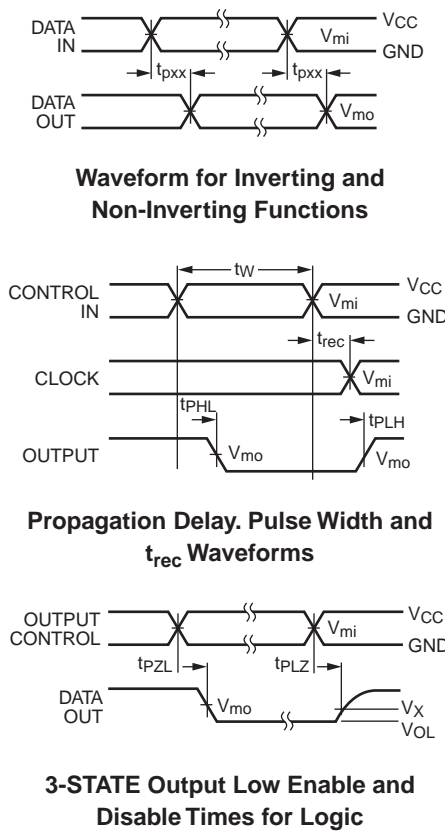
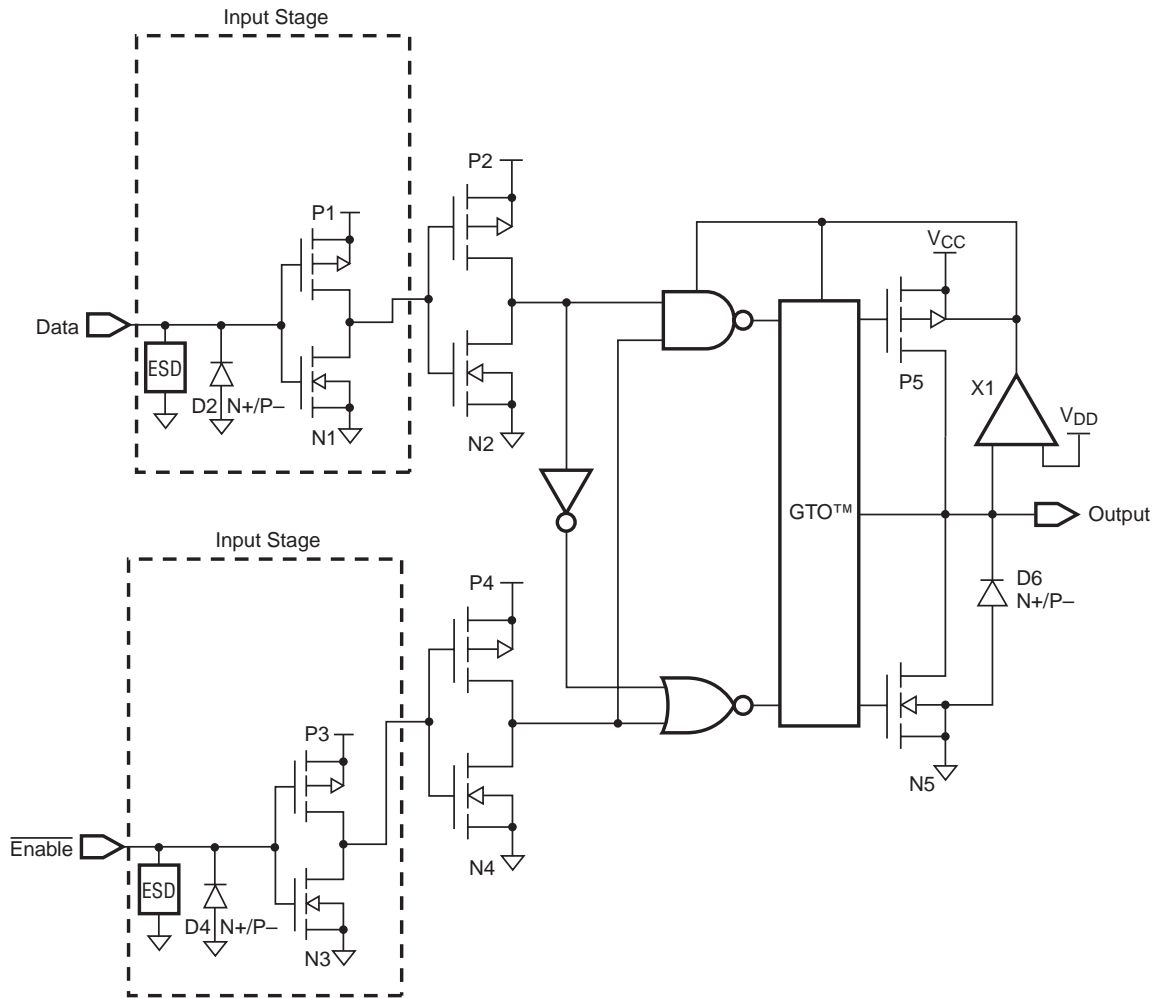

Figure 2. Waveforms (Input Characteristics; $f = 1MHz$, $t_r = t_f = 3ns$)

Symbol	V_{CC}		
	$3.3V \pm 0.3V$	$2.7V$	$2.5V \pm 0.2V$
V_{mi}	1.5V	1.5V	$V_{CC} / 2$
V_{mo}	1.5V	1.5V	$V_{CC} / 2$
V_x	$V_{OL} + 0.3V$	$V_{OL} + 0.3V$	$V_{OL} + 0.15V$
V_y	$V_{OH} - 0.3V$	$V_{OH} - 0.3V$	$V_{OH} - 0.15V$

Schematic Diagram (Generic for LCX Family)



Tape and Reel Specification

Tape Format for DQFN

Package Designator	Tape Section	Number Cavities	Cavity Status	Cover Tape Status
BQX	Leader (Start End)	125 (typ)	Empty	Sealed
	Carrier	3000	Filled	Sealed
	Trailer (Hub End)	75 (typ)	Empty	Sealed

Tape Dimensions inches (millimeters)

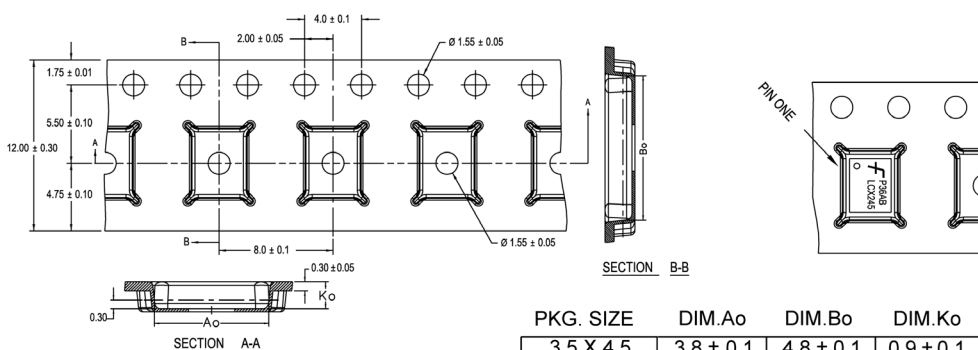

PKG. SIZE	DIM.A _o	DIM.B _o	DIM.K _o
3.5 X 4.5	3.8 ± 0.1	4.8 ± 0.1	0.9 ± 0.1
3.0 X 3.0	3.3 ± 0.1	3.3 ± 0.1	0.9 ± 0.1
2.5 X 4.5	2.8 ± 0.1	4.8 ± 0.1	0.9 ± 0.1
2.5 X 3.5	2.8 ± 0.1	3.8 ± 0.1	0.9 ± 0.1
2.5 X 3.0	2.8 ± 0.1	3.3 ± 0.1	0.9 ± 0.1
2.5 X 2.5	2.8 ± 0.1	2.8 ± 0.1	0.9 ± 0.1

DIMENSIONS ARE IN MILLIMETERS

NOTES: unless otherwise specified

1. Cumulative pitch for feeding holes and cavities (chip pockets) not to exceed 0.008[0.20] over 10 pitch span.
2. Smallest allowable bending radius.
3. Thru hole inside cavity is centered within cavity.
4. Tolerance is ±0.002[0.05] for these dimensions on all 12mm tapes.
5. A_o and B_o measured on a plane 0.120[0.30] above the bottom of the pocket.
6. K_o measured from a plane on the inside bottom of the pocket to the top surface of the carrier.
7. Pocket position relative to sprocket hole measured as true position of pocket. Not pocket hole.
8. Controlling dimension is millimeter. Dimension in inches rounded.

Reel Dimensions inches (millimeters)

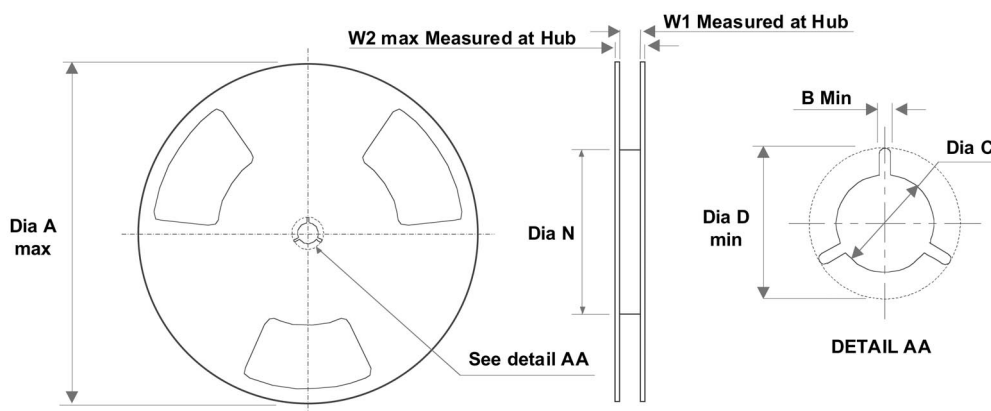

Tape Size	A	B	C	D	N	W1	W2
12 mm	13.0 (330.0)	0.059 (1.50)	0.512 (13.00)	0.795 (20.20)	2.165 (55.00)	0.488 (12.4)	0.724 (18.4)

Physical Dimensions inches (millimeters) unless otherwise noted

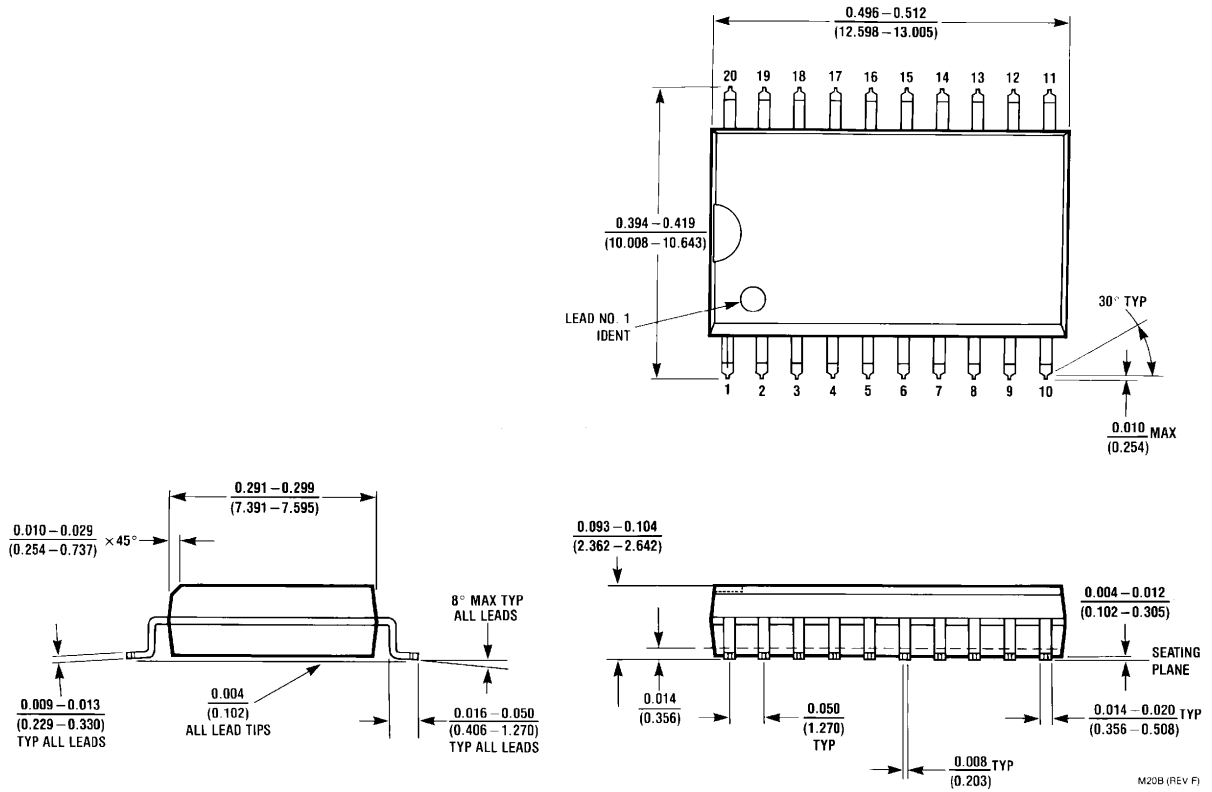

**20-Lead Small Outline Integrated Circuit (SOIC),
JEDEC MS-013, 0.300" Wide Package Number M20B**

Physical Dimensions (Continued) inches (millimeters) unless otherwise noted

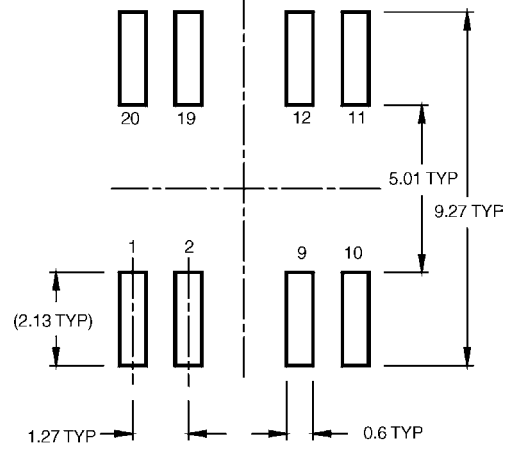
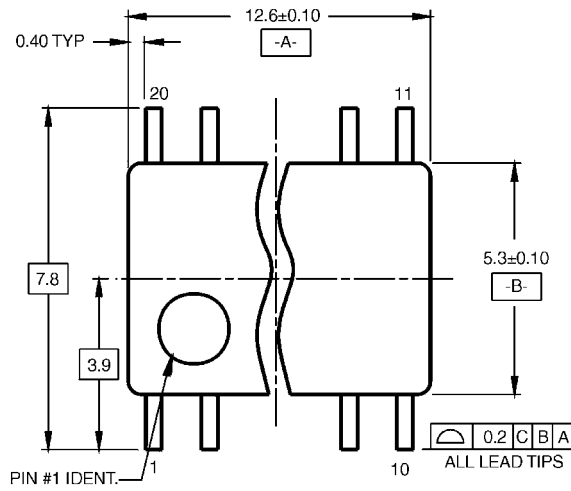

LAND PATTERN RECOMMENDATION

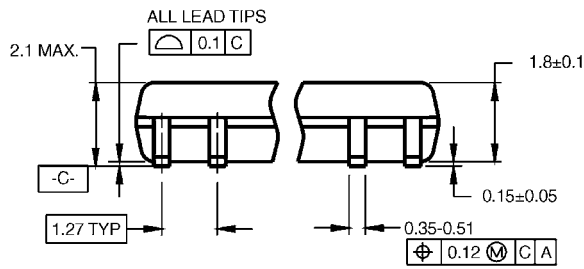

DIMENSIONS ARE IN MILLIMETERS

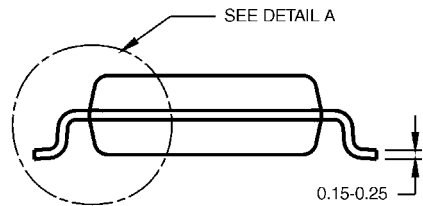

- NOTES:
- A. CONFORMS TO EIAJ EDR-7320 REGISTRATION, ESTABLISHED IN DECEMBER, 1998.
 - B. DIMENSIONS ARE IN MILLIMETERS.
 - C. DIMENSIONS ARE EXCLUSIVE OF BURRS, MOLD FLASH, AND TIE BAR EXTRUSIONS.

M20DRevB1

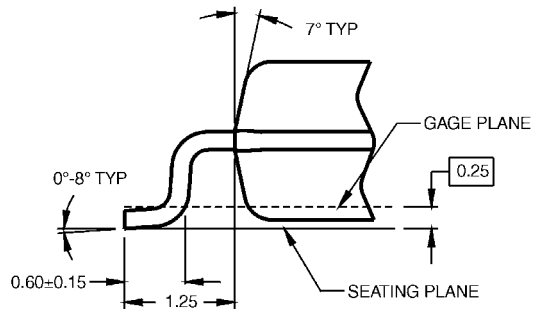

DETAIL A

**Pb-Free 20-Lead Small Outline Package (SOP),
EIAJ TYPE II, 5.3mm Wide Package Number M20D**

Physical Dimensions (Continued) inches (millimeters) unless otherwise noted

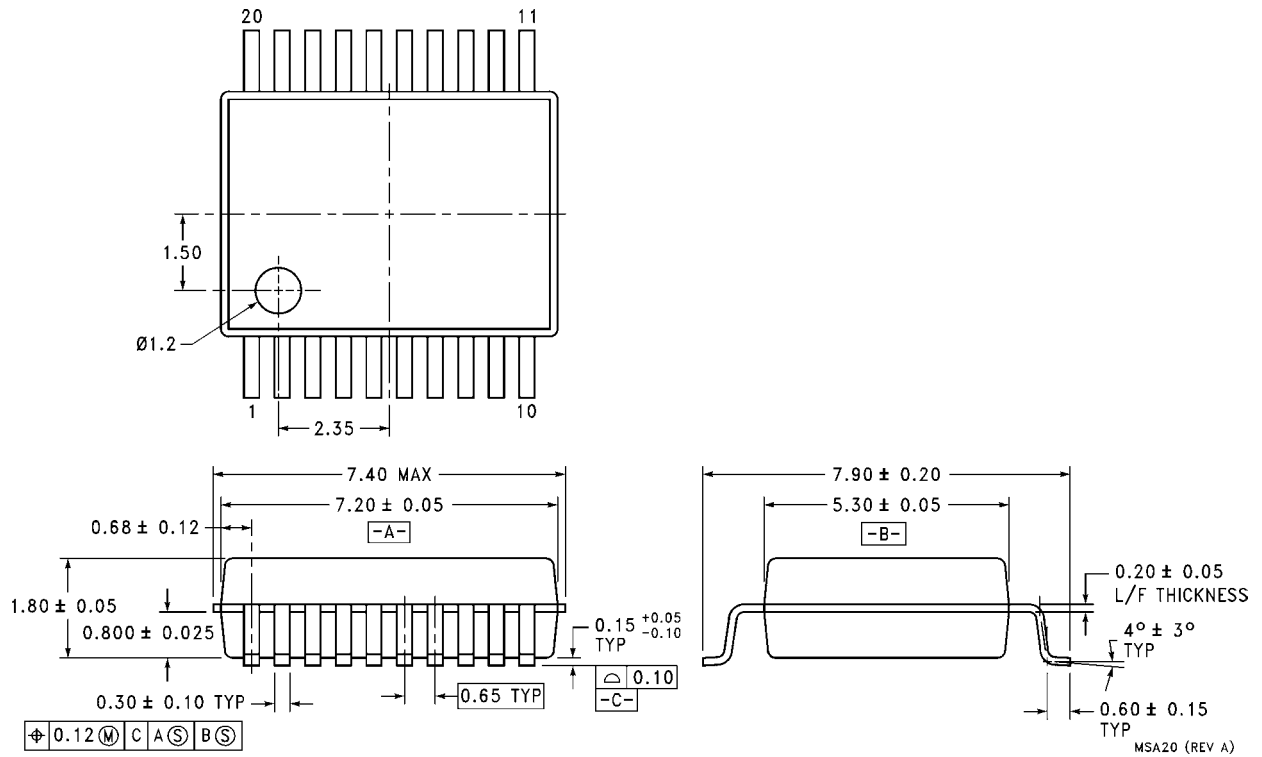

**20-Lead Shrink Small Outline Package (SSOP),
JEDEC MO-150, 5.3mm Wide Package Number MSA20**

Physical Dimensions (Continued) inches (millimeters) unless otherwise noted

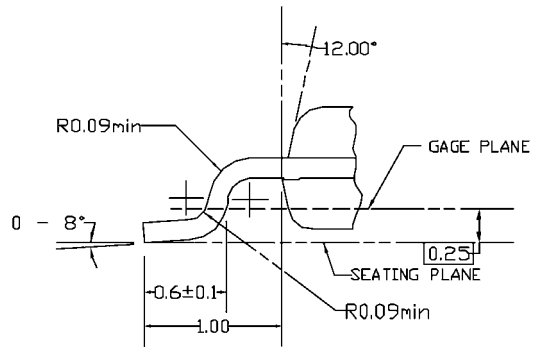
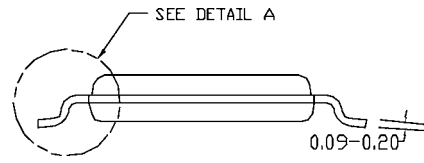
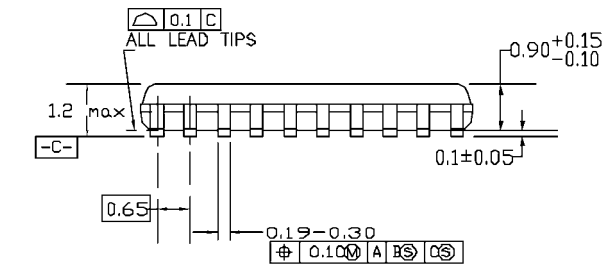
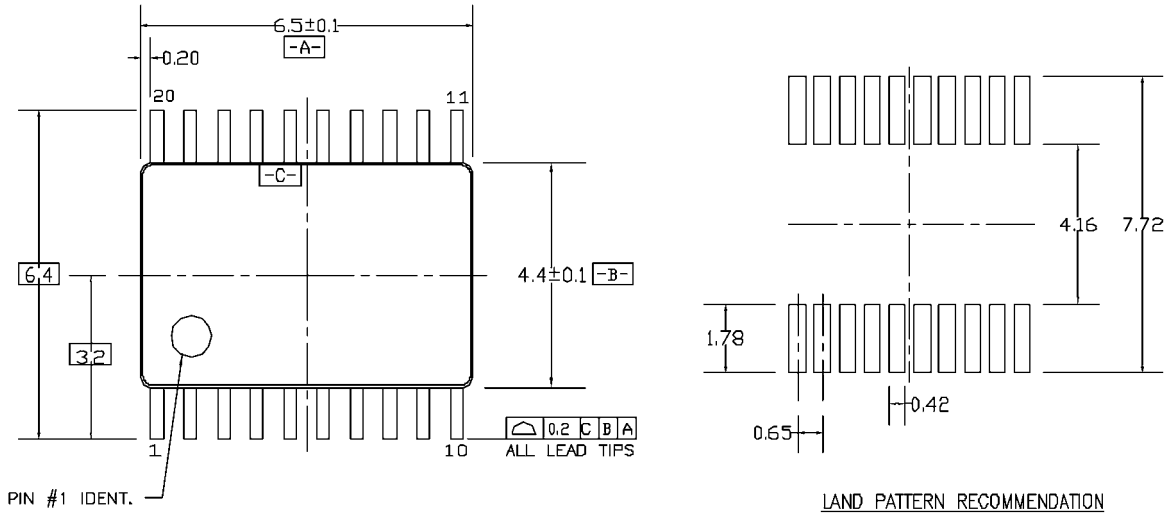

DIMENSIONS ARE IN MILLIMETERS

NOTES:

- A. CONFORMS TO JEDEC REGISTRATION MO-153, VARIATION AC, REF NOTE 6, DATE 7/93.
- B. DIMENSIONS ARE IN MILLIMETERS.
- C. DIMENSIONS ARE EXCLUSIVE OF BURRS, MOLDS FLASH, AND TIE BAR EXTRUSIONS.
- D. DIMENSIONS AND TOLERANCES PER ANSI Y14.5M, 1982.

MTC20REV.D1

**20-Lead Thin Shrink Small Outline Package (TSSOP),
JEDEC MO-153, 4.4mm Wide Package Number MTC20**

TRADEMARKS

The following are registered and unregistered trademarks Fairchild Semiconductor owns or is authorized to use and is not intended to be an exhaustive list of all such trademarks.

ACE [™]	FAST [®]	ISOPLANAR [™]	PowerSaver [™]	SuperSOT [™] -6
ActiveArray [™]	FAST _r [™]	LittleFET [™]	PowerTrench [®]	SuperSOT [™] -8
Bottomless [™]	FP [™]	MICROCOUPLER [™]	QFET [®]	SyncFET [™]
Build it Now [™]	FRFET [™]	MicroFET [™]	Q [™]	TCM [™]
CoolFET [™]	GlobalOptoisolator [™]	MicroPak [™]	QT Optoelectronics [™]	TinyLogic [®]
CROSSVOLT [™]	GTO [™]	MICROWIRE [™]	Quiet Series [™]	TINYOPTO [™]
DOMET [™]	HiSeC [™]	MSX [™]	RapidConfigure [™]	TruTranslation [™]
EcoSPARK [™]	I ² C [™]	MSXPro [™]	RapidConnect [™]	UHC [™]
E ² CMOS [™]	<i>i-Lo</i> [™]	OCX [™]	μSerDes [™]	UltraFET [®]
EnSigna [™]	ImpliedDisconnect [™]	OCXPro [™]	ScalarPump [™]	UniFET [™]
FACT [™]	IntelliMAX [™]	OPTOLOGIC [®]	SILENT SWITCHER [®]	VCX [™]
FACT Quiet Series [™]		OPTOPLANAR [™]	SMART START [™]	Wire [™]
Across the board. Around the world. [™]		PACMAN [™]	SPM [™]	
The Power Franchise [®]		POP [™]	Stealth [™]	
Programmable Active Droop [™]		Power247 [™]	SuperFET [™]	
		PowerEdge [™]	SuperSOT [™] -3	

DISCLAIMER

FAIRCHILD SEMICONDUCTOR RESERVES THE RIGHT TO MAKE CHANGES WITHOUT FURTHER NOTICE TO ANY PRODUCTS HEREIN TO IMPROVE RELIABILITY, FUNCTION OR DESIGN. FAIRCHILD DOES NOT ASSUME ANY LIABILITY ARISING OUT OF THE APPLICATION OR USE OF ANY PRODUCT OR CIRCUIT DESCRIBED HEREIN; NEITHER DOES IT CONVEY ANY LICENSE UNDER ITS PATENT RIGHTS, NOR THE RIGHTS OF OTHERS.

LIFE SUPPORT POLICY

FAIRCHILD'S PRODUCTS ARE NOT AUTHORIZED FOR USE AS CRITICAL COMPONENTS IN LIFE SUPPORT DEVICES OR SYSTEMS WITHOUT THE EXPRESS WRITTEN APPROVAL OF FAIRCHILD SEMICONDUCTOR CORPORATION. As used herein:

1. Life support devices or systems are devices or systems which, (a) are intended for surgical implant into the body, or (b) support or sustain life, or (c) whose failure to perform when properly used in accordance with instructions for use provided in the labeling, can be reasonably expected to result in significant injury to the user.
2. A critical component is any component of a life support device or system whose failure to perform can be reasonably expected to cause the failure of the life support device or system, or to affect its safety or effectiveness.

PRODUCT STATUS DEFINITIONS

Definition of Terms

Datasheet Identification	Product Status	Definition
Advance Information	Formative or In Design	This datasheet contains the design specifications for product development. Specifications may change in any manner without notice.
Preliminary	First Production	This datasheet contains preliminary data, and supplementary data will be published at a later date. Fairchild Semiconductor reserves the right to make changes at any time without notice in order to improve design.
No Identification Needed	Full Production	This datasheet contains final specifications. Fairchild Semiconductor reserves the right to make changes at any time without notice in order to improve design.
Obsolete	Not In Production	This datasheet contains specifications on a product that has been discontinued by Fairchild semiconductor. The datasheet is printed for reference information only.

Rev. 118