HD74CBT3245A

Octal FET Bus Switch

HITACHI

ADE-205-642 (Z)

Preliminary
Rev. 0
August 2001

Description

The HD74CBT3245A provides eight bits of high speed TTL-compatible bus switching in a standard '245 device pinout. The low on state resistance of the switch allows connections to be made with minimal propagation delay. The device is organized as one 8-bit switch. When output enable (\overline{OE}) is low, the switch is on, and port A is connected to port B. When \overline{OE} is high, the switch is open, and the high impedance state exists between the two ports.

Features

- Standard '245 type pinout.
 - Minimal propagation delay through the switch.
 - 5 Ω switch connection between two ports.
 - TTL-compatible input levels.
 - Ultra low quiescent power.
- Ideally suited for notebook applications.

Function Table

Input \overline{OE}	Function
L	A port = B port
H	Disconnect

H: High level
L: Low level

Pin Arrangement

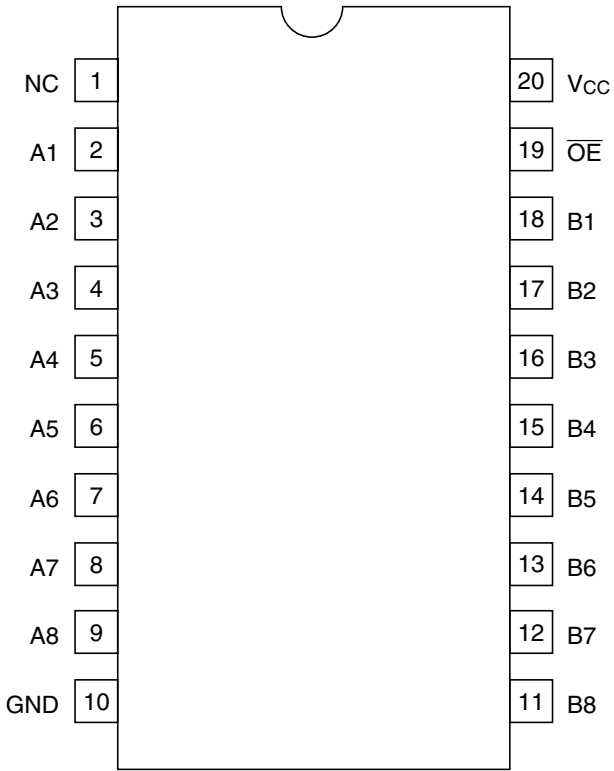

(Top view)

Absolute Maximum Ratings

Item	Symbol	Ratings	Unit	Conditions
Supply voltage range	V_{CC}	-0.5 to 7.0	V	
Input voltage range ¹	V_I	-0.5 to 7.0	V	
Input clamp current	I_{IK}	-50	mA	$V_I < 0$
Continuous output current	I_O	128	mA	$V_O = 0$ to V_{CC}
Continuous current through V_{CC} or GND	I_{CC} or I_{GND}	± 100	mA	
Maximum power dissipation at $T_a = 25^\circ\text{C}$ (in still air) ²	P_T	757	mW	TSSOP
Storage temperature	T_{stg}	-65 to 150	$^\circ\text{C}$	

Notes: The absolute maximum ratings are values which must not individually be exceeded, and furthermore, no two of which may be realized at the same time.

1. The input and output voltage ratings may be exceeded even if the input and output clamp-current ratings are observed.
2. The maximum package power dissipation was calculated using a junction temperature of 150°C .

Recommended Operating Conditions

Item	Symbol	Min	Max	Unit	Conditions
Supply voltage range	V_{CC}	4.0	5.5	V	
Input voltage range	V_I	0	5.5	V	
Output voltage range	V_{IO}	0	5.5	V	
Input transition rise or fall rate	$\Delta t / \Delta v$	0	5	ns / V	$V_{CC} = 4.5$ to 5.5 V
Operating free-air temperature	T_a	-40	85	$^\circ\text{C}$	

Note: Unused or floating inputs must be held high or low.

Block Diagram

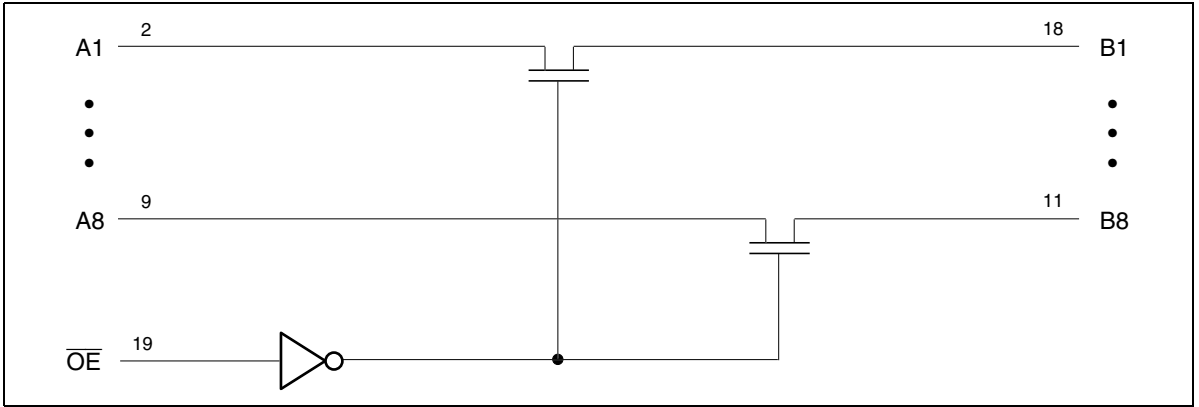

DC Electrical Characteristics

(Ta = -40 to 85°C)

Item	Symbol	V _{cc} (V)	Min	Typ ^{*1}	Max	Unit	Test conditions
Clamp diode voltage	V _{IK}	4.5	—	—	-1.2	V	I _{IN} = -18 mA
Input voltage	V _{IH}	4.0 to 5.5	2.0	—	—	V	
	V _{IL}	4.0 to 5.5	—	—	0.8		
On-state switch resistance ^{*2}	R _{ON}	4.5	—	5	7	Ω	V _{IN} = 0 V, I _{IN} = 64 mA
		4.5	—	5	7		V _{IN} = 0 V, I _{IN} = 30 mA
		4.5	—	10	15		V _{IN} = 2.4 V, I _{IN} = 15 mA
Input current	I _{IN}	0 to 5.5	—	—	±1.0	μA	V _{IN} = 5.5 V or GND
Off-state leakage current	I _{OZ}	5.5	—	—	±1.0	μA	0 ≤ A, B ≤ V _{cc}
Quiescent supply current	I _{CC}	5.5	—	—	3	μA	V _{IN} = V _{cc} or GND, I _O = 0 mA
Increase in I _{CC} per input ^{*3}	ΔI _{CC}	5.5	—	—	2.5	mA	One input at 3.4 V, other inputs at V _{cc} or GND

Notes: For condition shown as Min or Max use the appropriate values under recommended operating conditions.

1. All typical values are at V_{cc} = 5 V (unless otherwise noted), Ta = 25°C.
2. Measured by the voltage drop between the A and B terminals at the indicated current through the switch. On-state resistance is determined by the lower voltage of the two (A or B) terminals.
3. This is the increase in supply current for each input that is at the specified TTL voltage level rather than V_{cc} or GND.

Capacitance

(Ta = 25°C)

Item	Symbol	V _{cc} (V)	Min	Typ	Max	Unit	Test conditions
Control input capacitance	C _{IN}	5.0	—	3.5	—	pF	V _{IN} = 0 or 3 V
Input / output capacitance	C _{I/O (OFF)}	5.0	—	5	—	pF	V _O = 0 or 3 V OE = V _{cc}

Note: This parameter is determined by device characterization is not production tested.

Switching Characteristics

(Ta = -40 to 85°C)

- $V_{CC} = 4.0\text{ V}$

Item	Symbol	Min	Max	Unit	Test conditions	FROM (Input)	TO (Output)
Propagation delay time ¹⁾	t_{PLH} t_{PHL}	—	0.35	ns	$C_L = 50\text{ pF}$ $R_L = 500\ \Omega$	A or B	B or A
Enable time	t_{ZH} t_{ZL}	—	7.2	ns	$C_L = 50\text{ pF}$ $R_L = 500\ \Omega$	\overline{OE}	A or B
Disable time	t_{HZ} t_{LZ}	—	7.4	ns	$C_L = 50\text{ pF}$ $R_L = 500\ \Omega$	\overline{OE}	A or B

- $V_{CC} = 5.0 \pm 0.5\text{ V}$

Item	Symbol	Min	Max	Unit	Test conditions	FROM (Input)	TO (Output)
Propagation delay time ¹⁾	t_{PLH} t_{PHL}	—	0.25	ns	$C_L = 50\text{ pF}$ $R_L = 500\ \Omega$	A or B	B or A
Enable time	t_{ZH} t_{ZL}	1.9	6.5	ns	$C_L = 50\text{ pF}$ $R_L = 500\ \Omega$	\overline{OE}	A or B
Disable time	t_{HZ} t_{LZ}	2.1	7.6	ns	$C_L = 50\text{ pF}$ $R_L = 500\ \Omega$	\overline{OE}	A or B

Note: 1. The propagation delay is the calculated RC time constant of the typical on-state resistance of the switch and the specified load capacitance, when driven by an ideal voltage source (zero output impedance).

Test Circuit

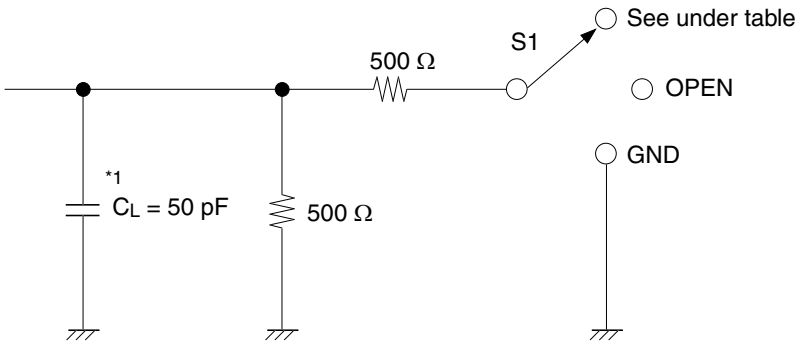

Load circuit for outputs

Symbol	S1
t_{PLH} / t_{PHL}	OPEN
t_{ZH} / t_{HZ}	OPEN
t_{ZL} / t_{LZ}	7 V

Note: 1. C_L includes probe and jig capacitance.

Waveforms - 1

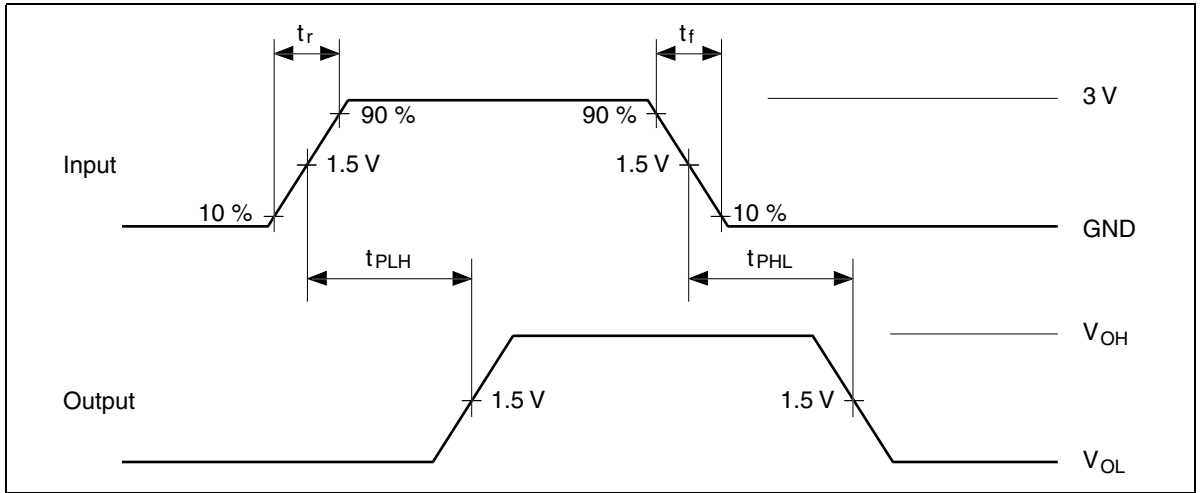

Waveforms - 2

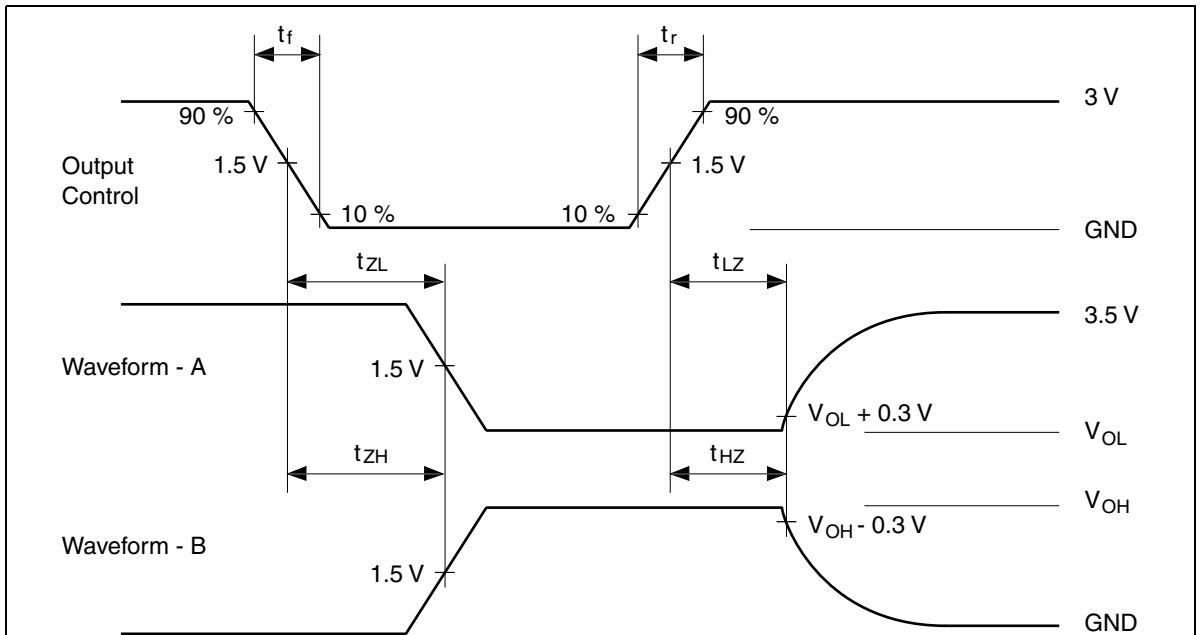

- Notes:
1. All input pulses are supplied by generators having the following characteristics :
 $PRR \leq 10 \text{ MHz}$, $Z_O = 50 \Omega$, $t_r \leq 2.5 \text{ ns}$, $t_f \leq 2.5 \text{ ns}$.
 2. Waveform - A is for an output with internal conditions such that the output is low except when disabled by the output control.
 3. Waveform - B is for an output with internal conditions such that the output is high except when disabled by the output control.
 4. The output are measured one at a time with one transition per measurement.

Package Dimensions

As of January, 2001
Unit: mm

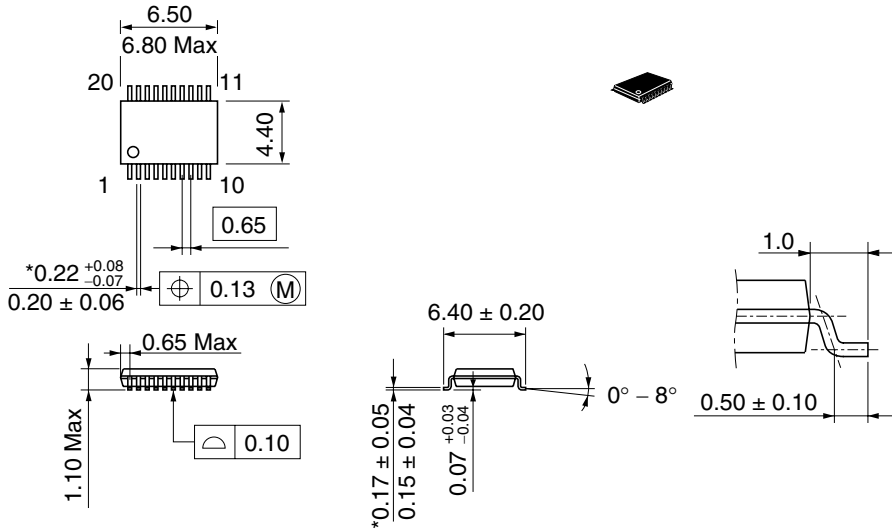

*Dimension including the plating thickness
Base material dimension

Hitachi Code	TTP-20DA
JEDEC	—
EIAJ	—
Mass (reference value)	0.07 g

Disclaimer

1. Hitachi neither warrants nor grants licenses of any rights of Hitachi's or any third party's patent, copyright, trademark, or other intellectual property rights for information contained in this document. Hitachi bears no responsibility for problems that may arise with third party's rights, including intellectual property rights, in connection with use of the information contained in this document.
2. Products and product specifications may be subject to change without notice. Confirm that you have received the latest product standards or specifications before final design, purchase or use.
3. Hitachi makes every attempt to ensure that its products are of high quality and reliability. However, contact Hitachi's sales office before using the product in an application that demands especially high quality and reliability or where its failure or malfunction may directly threaten human life or cause risk of bodily injury, such as aerospace, aeronautics, nuclear power, combustion control, transportation, traffic, safety equipment or medical equipment for life support.
4. Design your application so that the product is used within the ranges guaranteed by Hitachi particularly for maximum rating, operating supply voltage range, heat radiation characteristics, installation conditions and other characteristics. Hitachi bears no responsibility for failure or damage when used beyond the guaranteed ranges. Even within the guaranteed ranges, consider normally foreseeable failure rates or failure modes in semiconductor devices and employ systemic measures such as fail-safes, so that the equipment incorporating Hitachi product does not cause bodily injury, fire or other consequential damage due to operation of the Hitachi product.
5. This product is not designed to be radiation resistant.
6. No one is permitted to reproduce or duplicate, in any form, the whole or part of this document without written approval from Hitachi.
7. Contact Hitachi's sales office for any questions regarding this document or Hitachi semiconductor products.

Sales Offices

HITACHI

Hitachi, Ltd.

Semiconductor & Integrated Circuits
Nippon Bldg., 2-6-2, Ohte-machi, Chiyoda-ku, Tokyo 100-0004, Japan
Tel: (03) 3270-2111 Fax: (03) 3270-5109

URL <http://www.hitachisemiconductor.com/>

For further information write to:

Hitachi Semiconductor (America) Inc.
179 East Tasman Drive
San Jose, CA 95134
Tel: <1>(408) 433-1990
Fax: <1>(408) 433-0223

Hitachi Europe Ltd.
Electronic Components Group
Whitebrook Park
Lower Cookham Road
Maidenhead
Berkshire SL6 8YA, United Kingdom
Tel: <44> (1628) 585000
Fax: <44> (1628) 585200

Hitachi Asia Ltd.
Hitachi Tower
16 Collyer Quay #20-00
Singapore 049318
Tel : <65>-538-6533/538-8577
Fax : <65>-538-6933/538-3877
URL : <http://semiconductor.hitachi.com.sg>

Hitachi Asia (Hong Kong) Ltd.
Group III (Electronic Components)
7/F., North Tower
World Finance Centre,
Harbour City, Canton Road
Tsim Sha Tsui, Kowloon Hong Kong
Tel : <852>-(2)-735-9218
Fax : <852>-(2)-730-0281
URL : <http://semiconductor.hitachi.com.hk>

Hitachi Europe GmbH
Electronic Components Group
Dornacher Straße 3
D-85622 Feldkirchen
Postfach 201, D-85619 Feldkirchen
Germany
Tel: <49> (89) 9 9180-0
Fax: <49> (89) 9 29 30 00

Hitachi Asia Ltd.
(Taipei Branch Office)
4/F, No. 167, Tun Hwa North Road
Hung-Kuo Building
Taipei (105), Taiwan
Tel : <886>-(2)-2718-3666
Fax : <886>-(2)-2718-8180
Telex : 23222 HAS-TP
URL : <http://www.hitachi.com.tw>

Copyright © Hitachi, Ltd., 2001. All rights reserved. Printed in Japan.
Colophon 5.0