

8281/8282

LNB SUPPLY AND CONTROL VOLTAGE REGULATOR

11/18/2002

ABSOLUTE MAXIMUM RATINGS

at $T_A = +25^\circ\text{C}$

Load Supply Voltage, V_{IN}	47 V
Output Current, I_{OUT}	Internally Limited*
Output Voltage, V_{OUT}	-1V to 22 V
Switching Node, LX	-1V
Logic Input	-0.3 V to 7 V
Package Power Dissipation ($T_A = +25^\circ\text{C}$), P_D	
A8281SLB.....	56 °C/W**
A8282SLB.....	50 °C/W**

Operating Temperature Range,

T_A -20°C to +85°C

Junction Temperature, T_J +150°C

Storage Temperature Range,

T_S -55°C to +150°C

* Output current rating may be limited by duty cycle, ambient temperature, and heat sinking. Under any set of conditions, do not exceed the specified current rating or a junction temperature of 150°C.

** Measured on a PCB with 2 oz copper with ground area of 1 square inch.

Intended for analog and digital satellite receivers, the low noise block converter regulator (LNBR) is a monolithic linear and switching voltage regulator, specifically designed to provide the power and the interface signals to the LNB downconverter via the coaxial cable.

If the device is in stand-by mode (EN terminal LOW), the regulator output is disabled. This is to allow the antenna downconverters to be supplied/controlled by other satellite receivers sharing the same coaxial cable. In this mode the device will limit reverse current.

The A8281 is supplied in a 16-lead plastic SOIC with copper batwing tab (suffix "LB"). The A8282 is supplied is a 24-lead plastic SOIC with copper batwing tab (suffix "LB"). Operating temperature range is standard classification (suffix "S").

The A8282 is available for improved power dissipation as well as allowing direct replacement of Allegro's first generation LNBR device, the A8283SLB, with the exception of the bypass switch.

FEATURES

- LNB selection and stand-by function
- Built-in tone oscillator factory trimmed to 22 kHz facilitates DiSEqC™ encoding
- Tracking switch-mode power converter for lowest dissipation
- Externally adjustable short-circuit protection
- LNB short-circuit protection and diagnostics
- Auxiliary modulation input
- Internal over temperature protection
- Reverse current protection
- Cable Length Compensation (A8282 only)

This device incorporates features that have patents pending.

Always order by complete part number:

Part Number	Package
A8282SLBTR	24 Lead SOIC Tape/Reel
A8282SLB	24 Lead SOIC
A8281SLB	16 Lead SOIC

8281/8282

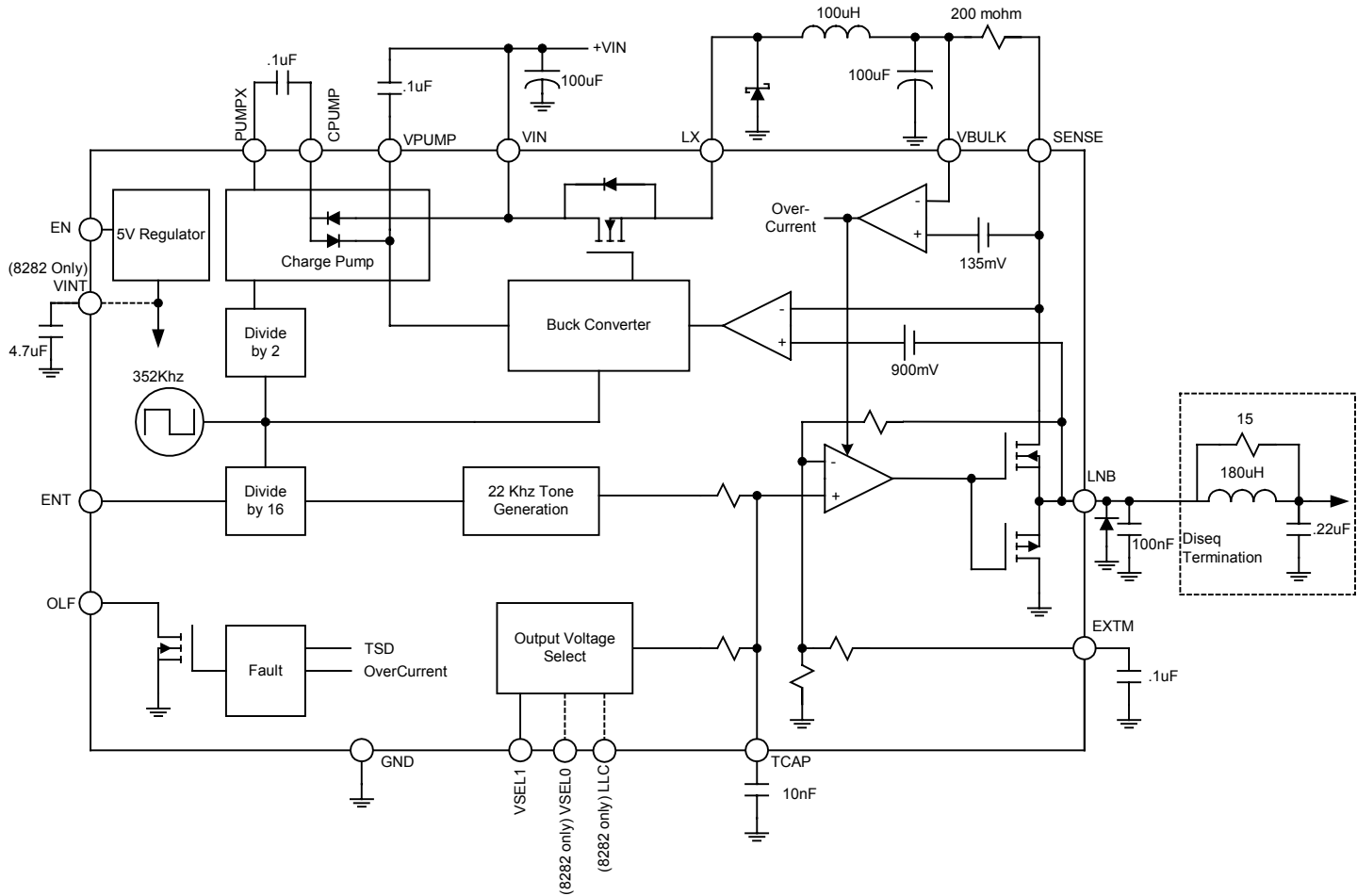

Output Voltage Select Table – A8282SLB

VSEL0	VSEL1	LLC	VLNB
L	L	L	13
L	L	H	14
L	H	L	18
L	H	H	19
H	L	L	12
H	L	H	13
H	H	L	20
H	H	H	21

Output Voltage Select Table – A8281SLB

VSEL1	VLNB
L	13
H	18

8281/8282

ELECTRICAL CHARACTERISTICS at $T_J = +125^{\circ}\text{C}$, $C_{LNB} = 100\text{nF}$ $V_{IN}=V_{INMIN}$ to 47V (unless noted otherwise)

Characteristics	Symbol	Test Conditions	Limits			
			Min.	Typ.	Max.	Units
V_{IN} Supply Voltage Range	V_{INMAX}				47	V
	V_{INMIN}		4.5+Vo			
Output Voltage	V_{LNB}	Relative to Voltage Select Table $I_{LOAD} = 6\text{mA}$ to 750mA	-4.5	0	4.5	%
Output Voltage	V_{LNB}	ENT=H, $I_{LOAD}=12\text{mA}$ to 750mA Average Voltage of LNB	-4.5	0	4.5	%
Logic Input Voltage	V_{il}				0.8	V
	V_{ih}		2.0			V
Logic Input Current	i_{ih}	$V_{ih}=5\text{V}$		< 1.0	10	μA
Supply current	I_{CC}	EN = L		.25	1	mA
	I_{CCEN}	EN = H, $I_{LOAD} = 0\text{mA}$		6	10	mA
Buck Switch On Resistance	R_{DSBUCK}	$T_J = 25^{\circ}\text{C}$, $I_{OUT}=750\text{mA}$.57	.67	Ω
		$T_J = 125^{\circ}\text{C}$, $I_{OUT}=750\text{mA}$.8	.94	Ω
Buck Switch Current Limit	I_{BLIM}		1		2.5	A
Switching frequency	f_o	$f_{TONE} * 16$	320	352	384	kHz
Linear regulator voltage drop	ΔV_{BUCK}	$V_{SENSE} - V_o$, ENT = L, $I_{LOAD}=750\text{mA}$	700	900	1100	mV
Linear Regulator On Resistance	R_{DSLNB}	$I_{LOAD} = 750\text{mA}$, $V_{IN} = 18\text{V}$, $T_J = 25^{\circ}\text{C}$ Output Select = 18V		.375		Ω

Tone Characteristics

Tone Frequency	f_{TONE}	ENT=H	20	22	24	kHz
Tone Amplitude	A_{TONE}	ENT = H, $I_{LOAD} = 12\text{mA}$ to 750mA	0.4	.65	0.9	V_{PP}
Tone Duty Cycle	DC_{TONE}	$I_{LOAD} = 12\text{mA}$ to 750mA	40		60	%
Tone rise or fall time	t_r, t_f	ENT=H, $I_{LOAD} = 12\text{mA}$ to 750mA	5	10	15	μs
External Modulation Gain	g_{EXTM}	$\Delta V_{OUT}/\Delta V_{EXTM}$, $f = 22\text{kHz}$ square wave, $I_{LOAD} = 12\text{mA}$ to 750mA	4	5.0	6	V/V
EXTM Input Range	ΔV_{EXTM}	Ac coupled	100		125	mVpp
External Modulation Impedance	Z_{EXTM}	$f = 22\text{kHz}$	4		10	$k\Omega$

- NOTES: 1. Typical Data is for design information only.
2. Negative current is defined as coming out of (sourcing) the specified device pin.

8281/8282

ELECTRICAL CHARACTERISTICS at $T_J = +125^{\circ}\text{C}$, $C_{LNB} = 100\text{nF}$ $V_{IN} = V_{INMIN}$ to 47V (unless noted otherwise)

Characteristics	Symbol	Test Conditions	Limits			
			Min.	Typ.	Max.	Units
Protection Circuitry						
Output Leakage Current	I_{OZ}	$V_{oh}=5.5\text{ V}$	< 1.0	10		μa
Overload flag terminal logic low	V_{ol}	$I_{ol}=8\text{ mA}$	0.28	.5		V
Output reverse current	I_{OR}	$EN=L$, $V_{LNB} = 22\text{ V}$ $V_{IN} = 22\text{ V}$ or V_{IN} floating	1.0	5		mA
Current Limiting Threshold	V_{OMTH}		115	135	155	mV
Thermal Shutdown Threshold	T_J			165		$^{\circ}\text{C}$
Thermal Shutdown Hysteresis	ΔT_J			20		$^{\circ}\text{C}$

- NOTES: 1. Typical Data is for design information only.
 2. Negative current is defined as coming out of (sourcing) the specified device pin.

8281/8282

Functional Description

Buck Regulator. A current-mode buck converter provides the linear regulator a supply voltage that tracks the requested LNB output voltage. The buck converter operates at 16 times the internal tone frequency, nominally 352kHz.

The tracking regulator provides minimum power dissipation across the range of output voltages by adjusting the SENSE pin voltage 900 mV nominally above the LNB output selected. The tracking Regulator also provides adequate headroom for tone injection.

Linear Regulator. The output linear regulator will sink and source current. This allows tone modulation into a capacitive load of 100nF for the output current range of 12mA to 750mA.

Slew Rate Control. The programmed output voltage rise and fall times can be set by an internal 25 k Ω resistor and an external capacitor located on the TCAP terminal. The range of acceptable capacitor values is 4.7nF to 47nF. This feature only affects the turn on and programmed voltage rise and fall times. Modulation is unaffected by the choice of TCAP. If LNB output voltage rise and fall time is not a concern, the TCAP terminal should use a 100nF ceramic as a default value to minimize output noise. If a small value capacitor value is used, the rise time will be limited by the time required to charge the VBULK capacitor.

Short Circuit Limit Regulator. The LNB output is current limited. The short-circuit protection threshold is set by the value of an external resistor, R_{SENSE} in conjunction with an internal 135mV \pm 20mV reference voltage, V_{OMTH} .

$$I_{OM} = V_{OMTH}/R_{SENSE}$$

The sense resistor should be chosen based on maximum DC plus AC (tone), load current required, internal V_{OMTH} tolerance, and sense resistor accuracy. For 750mA applications, a precision 140mohm resistor is recommended. For 500mA applications the resistor value can be raised to 200mohms.

In operation, the short-circuit protection produces current limiting at the input due to the tracking converter. If the output is shorted, the linear regulator will limit the output current to I_{OM} .

Fault Output. Short-circuit or thermal shutdown will cause the OLF terminal, an open-drain diagnostic output flag, to go LOW.

Internal Tone Modulation. The ENT (Tone Enable) terminal activates the internal tone signal modulating the dc output with a 650mV peak to peak, trapezoidal waveform. The internal oscillator is factory trimmed to provide a tone of 22 kHz \pm 2 kHz. No further adjustment is required. Burst coding of the 22 kHz tone can be accomplished, due to the fast response of the ENT input and rapid tone response. This allows implementation of the DiSEqC™ protocols.

External Tone Modulation. To improve design flexibility and to allow implementation of proposed LNB remote control standards, an analog modulation input terminal is available (EXTM). An appropriate dc blocking capacitor must be used to couple the modulating signal source to the EXTM terminal. If external modulation is not used, the EXTM terminal should be bypassed to ground via a .1 μ F ceramic capacitor. The input amplitude should stay within 100 to 125mVpp to guarantee the DiSEqC™ amplitude specification over the output current range.

8281/8282

Typical Application Diagram

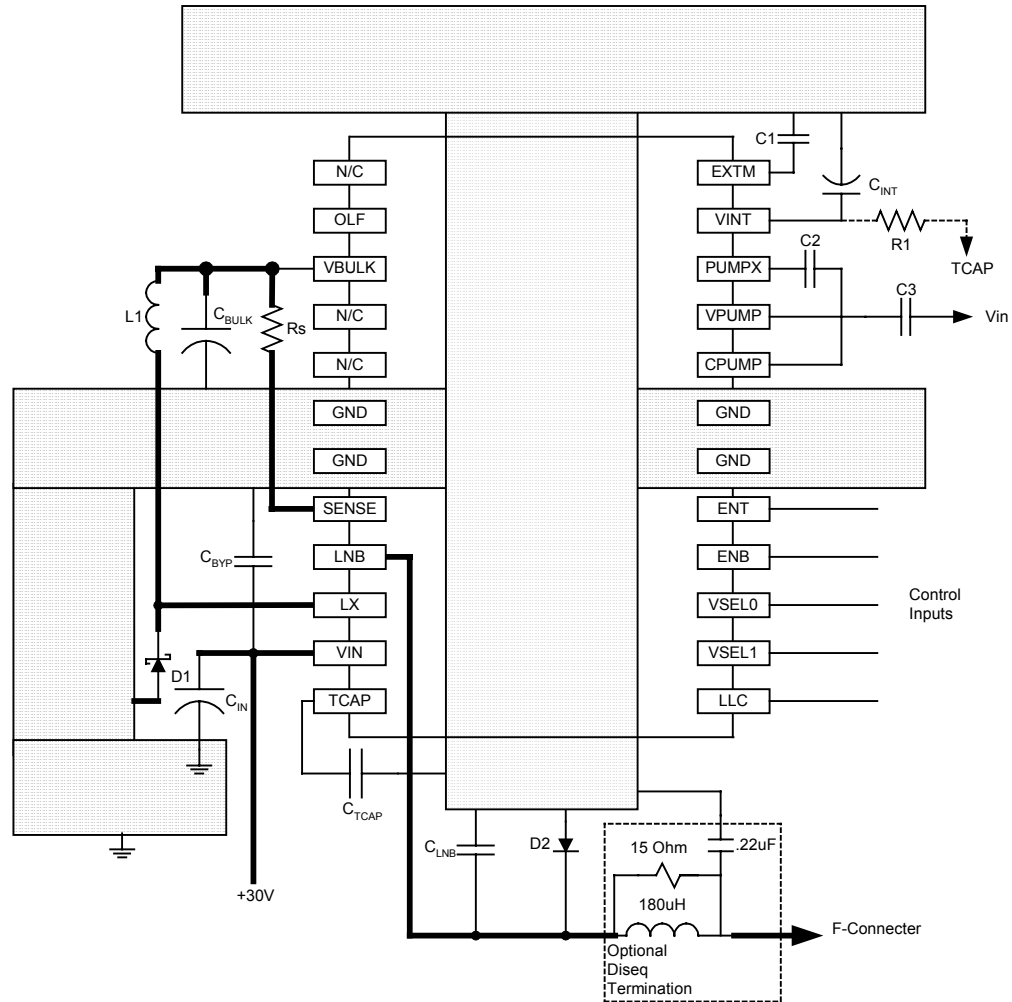

	Description	Representative Component
C1-3, C _{BYP} , C _{LNB}	.1uF/50V ceramic X7R/X5R	
C _{IN}	100uF Low ESR electrolytic 50V	Nichicon UHD1H101MPT
C _{BULK}	100uF Low ESR electrolytic/35V	Nichicon UHC1V101
C _{INT}	4.7uF/16V tantalum/electrolytic	
D1	1.5A Schottky/40V or 50V	Sanken EK04
D2	1A Silicon Diode/25V	Sanken EU01
L1	100uH (750mA max Iload) 100uH (500mA max Iload)	TDK TSL1112-101K1R4 Falco D08018, Coilcraft DR0808, TDK TSL0808-101KR80
L2	180uH (750mA Iload)	TDK TSL1112S-181K1R0-PF
RS	140-200mOhm sense resistor .25W	Meritek CR04R140F
C _{TCAP}	10nF ceramic X7R/X5R	
R1	1M 5%	

8281/8282

Component Selection.

Input Capacitor (C_{IN}). An electrolytic should be located as close to the device as possible. The input current is a square wave with fast rise and fall times so the capacitor must be able to handle the rms current without excessive temperature rise. The value of the capacitor is not as important as the ESR. The power dissipated in the input electrolytic is

$$Pd(C_{IN}) = I_{RMS}^2 * ESR$$

The worse case Irms is with maximum I_{LOAD} , minimum V_{IN} , and maximum V_{OUT} (highest switch duty cycle). Choose a capacitor with a ripple current rating greater than

$$I_{LOAD} * 1.2 * V_{OUT(MAX)} / V_{IN(MIN)}$$

Buck Inductor ($L1$). A 100uH power inductor is appropriate for all operating conditions. The rated saturation current of the inductor must be $> 1.3A$. The dc resistance should be less than 350mohms, the smaller the better to maximize efficiency.

Clamp Diode ($D1$). A schottky diode is required for the switching node LX. The diode should be rated at 1.5 times the maximum load current.

Output Capacitor (C_{BULK}). A low ESR electrolytic is recommended to minimize the Vpp ripple voltage. Less than 40mV Vpp is a reasonable goal.

$$V_{pp} = ESR * I_{RIPPLE}$$

$$I_{RIPPLE} = (V_{BULK} * (1 - V_{BULK} / V_{IN})) / (L1 * 352kHz)$$

Layout Notes.

1. Use a star ground approach. Connect the common ground to the ground plane at the device ground pins. The SOIC-24 has 2 pins on each side connected to the package power ground tab. This allows the analog and power ground to be kept separate on the PCB up to the device.
2. Keep the sense resistor PCB trace as short and wide as possible to lower trace resistance.
3. Connect the bypass capacitors as close to the device as possible. The lower valued ceramic capacitors should be closer to the device than electrolytics.
4. If using an unshielded power inductor for the buck switch, place as far away from the device as possible. The resulting EMI can result in additional noise on the LNB output.
5. Place the TCAP capacitor as close to the device as possible.

6. A two-sided board with ground planes on both sides of the PCB will help optimize the power dissipation. Typically several copper Vias under the device are used to connect the ground planes and enhance thermal performance.

Noise Immunity. LNB systems can have a 50mV peak specification for noise on the coaxial cable. This is easily achievable with the A8282 with proper layout and following a few guidelines.

1. Use a low ESR capacitor for VBULK, 400mohm maximum is recommended.
2. The LNB output is sensitive to the TCAP reference pin. Keep the PCB traces short and location of the bypass capacitor close to the device. This pin is a high impedance node and noise can be induced from the proximity to an unshielded inductor. If the inductor can not be placed far enough away to avoid this noise pickup, it is important to ensure that the induced voltage is out of phase with the switching node LX. Rotating the inductor can change the phase of the induced voltage.
3. Be sure to place a 1uF to 10uF capacitor on internal reference VINT.
4. Bypass the EXTM pin with a .1uF ceramic to GND.
5. Increasing output capacitance will attenuate noise, however this must be traded off with the requirement for low cable capacitance for 22khz-tone transmission.

8281/8282

Power Dissipation. The power dissipated and operating junction temperature of the 8281 and 8282 can be estimated to ensure the device operates within desired thermal budget.

The total chip power is contributed by three components.

$$P_{d_bias} = V_{IN} * (I_{CCEN} - 4mA)$$

$$P_{d_buck} = I_{LOAD}^2 * R_{DSBUCK} * V_{BULK} / V_{IN}$$

$$P_{d_lin} = \Delta V_{BUCK} * I_{LOAD}$$

$$P_{TOT} = P_{d_bias} + P_{d_buck} + P_{d_lin}$$

Where $V_{BULK} = \Delta V_{BUCK} + I_{LOAD} * R_{SENSE} + V_{LNB}$
 I_{CCEN} , ΔV_{BUCK} , and R_{DSBUCK} can be taken from the specification table. R_{DSBUCK} is a function of junction temperature. The $R_{DS(ON)}$ will rise approximately 2.7mohm/°C.

The junction temperature can be estimated by:

$$T_J = P_{TOT} * R_{\theta JA} + T_A$$

OR

$$T_J = P_{TOT} * R_{\theta JT} + T_{TAB}$$

Where $R_{\theta JT} = 5.6^\circ\text{C} / \text{W}$
 $T_A = \text{Ambient Temperature } ^\circ\text{C}$
 $R_{\theta JA} = 50^\circ\text{C} / \text{W}$ for A8282SLB
 $56^\circ\text{C} / \text{W}$ for A8281SLB

$R_{\theta JA}$ numbers for a typical two sided, 2 oz. copper, PC board layout with copper ground plane of 1 square inch. Additional copper ground plane area, multi-level boards, etc can reduce the effective $R_{\theta JA}$.

DiSEqC™. The 22khz tone is specified to be compatible to coaxial cable bus standards available from www.eutelsat.com. The A8282 LNB output will be able to drive the DiSEqC termination network. This terminator typically consists of a 180uH inductor, used to pass the dc current with minimal loss, and a 15 ohm parallel resistor to provide the recommended source impedance at 22khz.

Unidirectional communication systems such as DiSEqC 1.0 do not need this termination and the LNB output can be directly connected to the coaxial cable.

13V to 18V Transition. The LNB output can be rapidly switched between a high and low setting as a method of receiver to LNB communication. The TCAP capacitor will control the slew rate based on the RC charging.

$$t_{RISE/FALL} = 25K * C_{TCAP} * \ln(V1/V2)$$

Small values of TCAP are used when the transition time is desired to be less than a millisecond. In this case, the minimum rise time is limited by the charge time of the switching regulators output capacitor. This is dependent on the LNB load current, peak current limit in the buck switch, and the output amplitude change.

$$t_{RISE} = C_{bulk} * (v2-v1) / (I_{ave})$$

Where I_{ave} is the average current available to charge the output capacitor and can be estimated by:

$$I_{ave} = 1.4A - I_{load}$$

Note that this is only a limitation due to the ability to charge the output capacitor on a low to high change of the LNB voltage. For high to low transitions, the output voltage will be slew limited by TCAP.

The minimum value for TCAP should be 4.7nF.

8281/8282

Output Voltage Adjust. It is possible to fine tune the LNB output voltage to comply with the DirectTV specification by connecting a 1M resistor from pin VINT to TCAP.

The LNB is output gained up by 6 from the TCAP voltage as shown. The 1M resistor pulls the LNB voltage up 440mV from the 13V nominal setting of the voltage select DAC by sourcing approximately $2.76\mu\text{A}$ into the TCAP node.

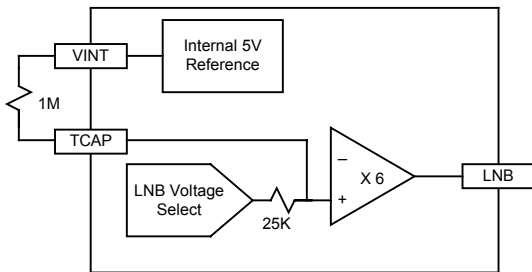

Capacitive Loading. The linear regulator sink current is limited which can cause overshoot of the 22Khz tone. This effect only appears with low levels of output current combined with high values of output capacitance. This relationship is chart below. Points above the line will not have excessive overshoot.

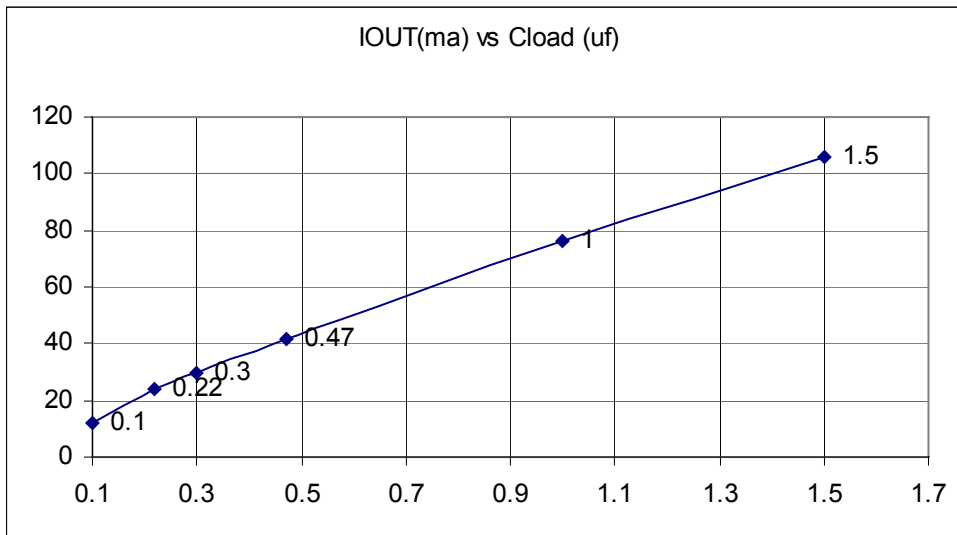

8281/8282

Pin Name	Pin Description	8281SLB SO-16	8282SLB SO-24
EXTM	External modulation input	1	24
OLF	Overload flag output	2	2
VBULK	Tracking supply voltage to linear regulators	3	3
GND	Ground tab	4	6,7
SENSE	Current limit setup resistor	5	8
LNB	Output voltage to LNB	6	9
LX	Inductor drive point	7	10
VIN	Supply input voltage	8	11
TCAP	Capacitor for setting the rise and fall time of the outputs	9	12
LLC	Logic input: increases output voltage by 1 V for line length	-	13
VSEL1	Logic input: output voltage select	10	14
VSEL0	Logic input: output voltage select	-	15
EN	Logic input: enables switcher and outputs	11	16
ENT	Logic input: enable internal modulation	12	17
GND	Ground tabs	13	18,19
CPUMP	High side of charge-pump cap	14	20
VPUMP	Gate supply voltage for high side drivers	15	21
PUMPX	Charge-pump drive	16	22
VINT	Internal regulated supply	-	23
N/C	No Connect		1,4,5