

## TB62725BPG, TB62725BFG, TB62725BFNG

### 8-bit Constant-Current LED Driver of the 3.3-V and 5-V Power Supply Voltage Operation

The TB62725BPG/BFG/BFNG are comprised of constant-current drivers designed for LEDs and LED displays. The output current value can be set using an external resistor.

As a result, all outputs will have virtually the same current levels.

This driver incorporates an 8-bit constant-current output, an 8-bit shift register, an 8-bit latch circuit and an 8-bit AND-gate circuit.

These drivers have been designed using the Bi-CMOS process. This devices are a product for the Pb free.

### Features

Output current capability and number of outputs:  
90 mA × 8 outputs

Constant current range: 5 to 80 mA

Application output voltage:

0.7 V (output current 5 to 80 mA)

0.4 V (output current 5 to 40 mA)

For anode-common LEDs

Input signal voltage level: 3.3-V and 5-V CMOS level (Schmitt trigger input)

Maximum output terminal voltage: 17 V

Serial data transfer rate: 20 MHz (max, cascade connection)

Operating temperature range:  $T_{opr} = -40$  to  $85^{\circ}\text{C}$

Package:

Type BPG: DIP16-P-300-2.54A

Type BFG: SSOP16-P-225-1.00A

Type BFNG: SSOP16-P-225-0.65B

Package and pin layout: Pin layout and functionality are similar to those of the TB62705C series and TB62725A series.

(Each characteristic value is different.)

Constant-current accuracy (all outputs on)

Output Voltage	Current Error between Bits	Current Error between ICs	Output Current
$\geq 0.4$ V	$\pm 6\%$	$\pm 15\%$	5 to 40 mA
$\geq 0.7$ V			5 to 90 mA

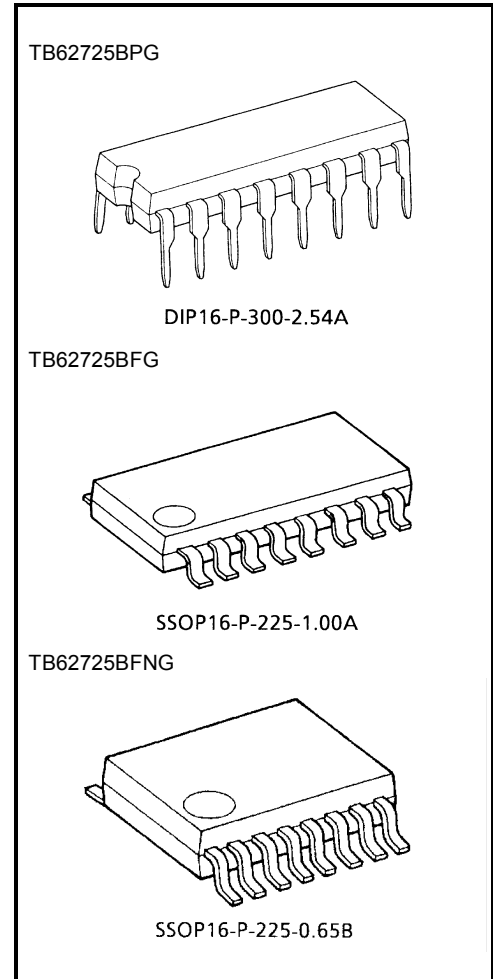

### Weight

DIP16-P-300-2.54A: 1.11 g (typ.)

SSOP16-P-225-1.00A: 0.14 g (typ.)

SSOP16-P-225-0.65B: 0.07 g (typ.)

## Pin Assignment (top view)

Pin layout and functionality are similar to those of the TB62705C. (each characteristic value is different.)

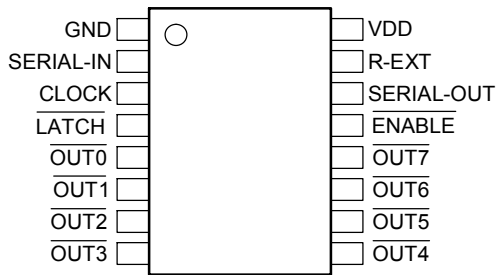

## Block Diagram

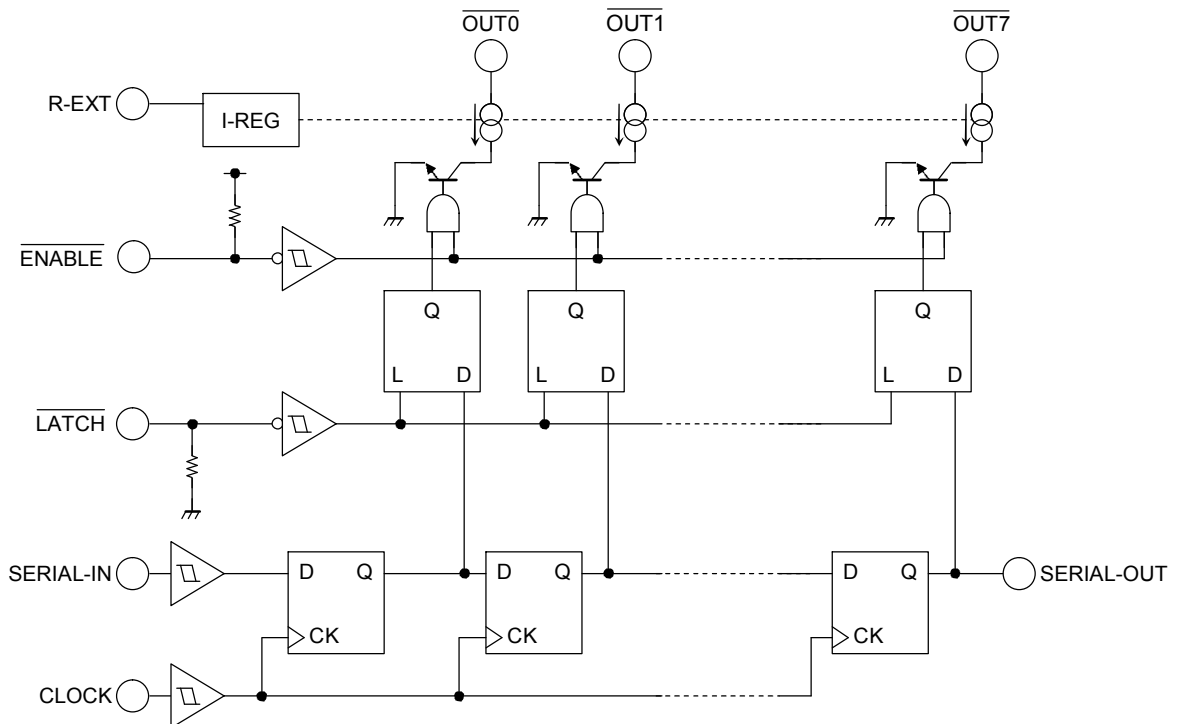

## Truth Table

CLOCK	LATCH	ENABLE	SERIAL-IN	OUT0 --- OUT5 --- OUT7	SERIAL-OUT
$\uparrow$	H	L	D <sub>n</sub>	D <sub>n</sub> --- D <sub>n-5</sub> --- D <sub>n-7</sub>	D <sub>n-7</sub>
$\uparrow$	L	L	D <sub>n+1</sub>	No change	D <sub>n-6</sub>
$\uparrow$	H	L	D <sub>n+2</sub>	D <sub>n+2</sub> --- D <sub>n-3</sub> --- D <sub>n-5</sub>	D <sub>n-5</sub>
$\downarrow$	X	L	D <sub>n+3</sub>	D <sub>n+2</sub> --- D <sub>n-3</sub> --- D <sub>n-5</sub>	D <sub>n-5</sub>
$\downarrow$	X	H	D <sub>n+3</sub>	Off	D <sub>n-5</sub>

Note 1:  $\overline{\text{OUT0}}$  to  $\overline{\text{OUT7}}$  = On when D<sub>n</sub> = H; to  $\overline{\text{OUT0}}$  to  $\overline{\text{OUT7}}$  = Off when D<sub>n</sub> = L.

In order to ensure that the level of the power supply voltage is correct, an external resistor must be connected between R-EXT and GND.

## Timing Diagram

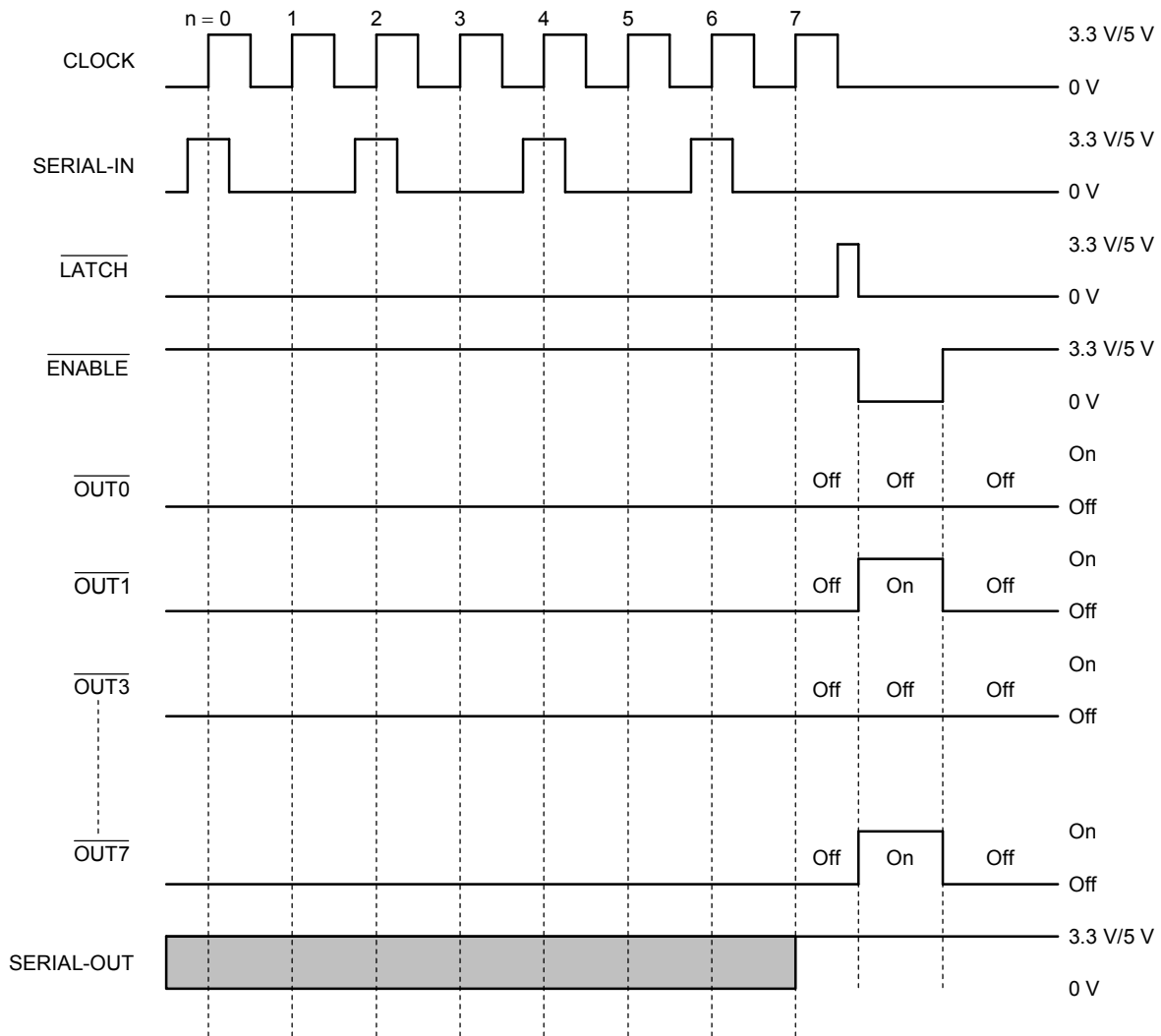

Warning: Latch circuit is leveled-latch circuit. Be careful because it is not triggered-latch circuit.

Note 2: The latches circuit holds data by pulling the  $\overline{\text{LATCH}}$  terminal Low.

And, when  $\overline{\text{LATCH}}$  terminal is a high-level, latch circuit doesn't hold data, and it passes from the input to the output.

When  $\overline{\text{ENABLE}}$  terminal is a low-level, output terminal  $\overline{\text{OUT0}}$  to  $\overline{\text{OUT7}}$  respond to the data, and on and off does.

Attention: This IC can be used in 3.3 V or 5.0 V. However, use the  $V_{DD}$  power supply and the input level in the same voltage system.

## Terminal Description

Pin No.	Pin Name	Function
1	GND	GND terminal for control logic.
2	SERIAL-IN	Input terminal for serial data for data shift register.
3	CLOCK	Input terminal for clock for data shift on rising edge.
4	$\overline{\text{LATCH}}$	Input terminal for data strobe. When the $\overline{\text{LATCH}}$ input is driven High, data is latched. When it is pulled Low, data is hold.
5 to 12	$\overline{\text{OUT0}}$ to $\overline{\text{OUT7}}$	Constant-current output terminals.
13	$\overline{\text{ENABLE}}$	Input terminal for output enable. All outputs ( $\overline{\text{OUT0}}$ to $\overline{\text{OUT7}}$ ) be turned off, when the $\overline{\text{ENABLE}}$ terminal is driven High. And are turned on, when the terminal is driven Low.
14	SERIAL-OUT	Output terminal for serial data input on SERIAL-IN terminal.
15	R-EXT	Input terminal used to connect an external resistor. This regulated the output current.
16	V <sub>DD</sub>	3.3-V and 5-V supply voltage terminal.

## Equivalent Circuits for Inputs and Outputs

### $\overline{\text{ENABLE}}$ Terminal

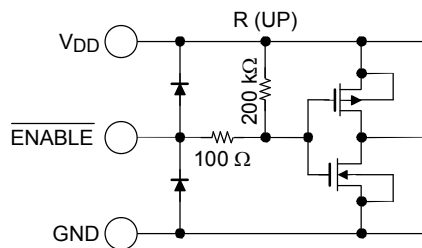

### $\overline{\text{LATCH}}$ Terminal

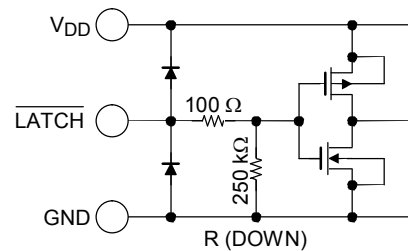

### CLOCK, SERIAL-IN Terminal

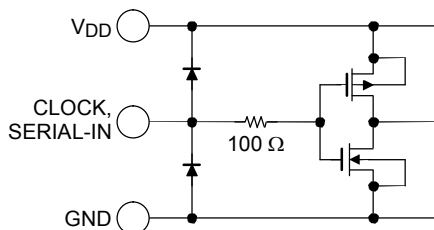

### SERIAL-OUT Terminal

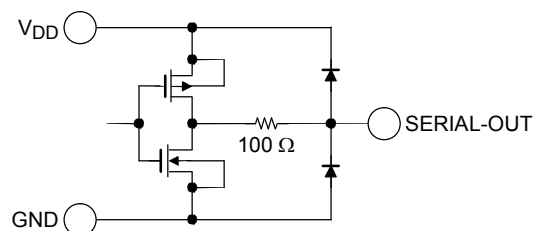

### $\overline{\text{OUT0}}$ to $\overline{\text{OUT7}}$ Terminals

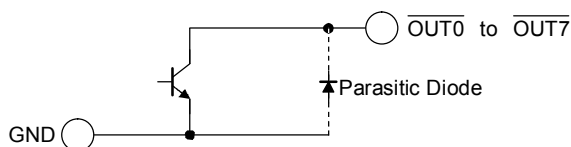

## Maximum Ratings (T<sub>opr</sub> = 25°C)

Characteristics		Symbol	Rating	Unit
Supply voltage		V <sub>DD</sub>	6	V
Input voltage		V <sub>IN</sub>	-0.2 to V <sub>DD</sub> + 0.2	V
Output current		I <sub>OUT</sub>	90	mA/ch
Output voltage		V <sub>OUT</sub>	-0.2 to 17	V
Power dissipation (Note 3)	BPG-type (when not mounted)	P <sub>d1</sub>	1.47	W
	BFG/BFNG-type (when not mounted)	P <sub>d2</sub>	0.37	
	BFG/BFNG-type (on PCB)		0.78	
Thermal resistance (Note 3)	BPG-type (when not mounted)	R <sub>th (j-a) 1</sub>	85	°C/W
	BFG/BFNG-type (when not mounted)	R <sub>th (j-a) 2</sub>	330	
	BFG/BFNG-type (on PCB)	R <sub>th (j-a) 3</sub>	160	
Operating temperature		T <sub>opr</sub>	-40 to 85	°C
Storage temperature		T <sub>stg</sub>	-55 to 150	°C

Note 3: BPG-type: Power dissipation is delated by 11.76 mW/°C if device is mounted on PCB and ambient temperature is above 25°C.

BFG and BFNG-type: Power dissipation is delated by 7.69 mW/°C if device is mounted on PCB and ambient temperature is above 25°C. With device mounted on glass-epoxy PCB of less than 40% Cu and of dimensions 50 mm × 50 mm × 1.6 mm

## Recommended Operating Conditions (T<sub>opr</sub> = -40°C to 85°C unless otherwise specified)

Characteristics	Symbol	Test Condition	Min	Typ.	Max	Unit
Supply voltage	V <sub>DD</sub>	—	3		5.5	V
Output voltage	V <sub>OUT</sub>	—	—	0.7	4	V
Output current	I <sub>OUT</sub>	Each DC 1 circuit	5	—	80	mA/ch
	I <sub>OH</sub>	SERIAL-OUT	—	—	-1	mA
	I <sub>OL</sub>	SERIAL-OUT	—	—	1	
Input voltage	V <sub>IH</sub>	—	0.7 × V <sub>DD</sub>	—	V <sub>DD</sub> + 0.15	mA
	V <sub>IL</sub>		-0.15	—	0.3 × V <sub>DD</sub>	
Clock frequency	f <sub>CLK</sub>	Cascade Connected	—	—	20	MHz
LATCH pulse width	t <sub>wLATCH</sub>	—	50	—	—	ns
ENABLE pulse width (Note 4)	t <sub>wENABLE</sub>	I <sub>OUT</sub> ≥ 20 mA	2000	—	—	ns
		I <sub>OUT</sub> < 20 mA	3000	—	—	
CLOCK pulse width	t <sub>wCLOCK</sub>	—	25	—	—	ns
Set-up time for CLOCK terminal	t <sub>SETUP1</sub>		10	—	—	
Hold time for CLOCK terminal	t <sub>HOLD</sub>		10	—	—	
Set-up time for LATCH terminal	t <sub>SETUP2</sub>		50	—	—	

Note 4: When the pulse of the low level is inputted to the  $\overline{\text{ENABLE}}$  terminal held in the high level.

## Electrical Characteristics ( $V_{DD} = 5\text{ V}$ , $T_a = 25^\circ\text{C}$ unless otherwise specified)

Characteristics	Symbol	Test Condition		Min	Typ.	Max	Unit
Supply voltage	$V_{DD}$	Normal operation		4.5	5	5.5	V
Output current	$I_{OUT1}$	$V_{OUT} = 0.4\text{ V}$ , $V_{DD} = 3.3\text{ V}$	$R_{EXT} = 490\ \Omega$	29.84	35.10	40.36	mA
	$I_{OUT2}$	$V_{OUT} = 0.4\text{ V}$ , $V_{DD} = 5\text{ V}$	$R_{EXT} = 250\ \Omega$	29.58	34.80	40.02	
	$I_{OUT3}$	$V_{OUT} = 0.7\text{ V}$ , $V_{DD} = 3.3\text{ V}$	$R_{EXT} = 490\ \Omega$	58.40	68.70	79.00	
	$I_{OUT4}$	$V_{OUT} = 0.7\text{ V}$ , $V_{DD} = 5\text{ V}$	$R_{EXT} = 250\ \Omega$	57.55	67.70	77.85	
Output current Error between bits	$\Delta I_{OUT1}$	$V_{OUT} = 0.4\text{ V}$ , All outputs ON	$R_{EXT} = 490\ \Omega$	—	$\pm 1.5$	$\pm 6$	%
	$\Delta I_{OUT2}$	$V_{OUT} = 0.7\text{ V}$ , All outputs ON	$R_{EXT} = 250\ \Omega$	—	$\pm 1.5$	$\pm 6$	
Output leakage current	$I_{OZ}$	$V_{OUT} = 15\text{ V}$		—	1	5	$\mu\text{A}$
Input voltage	$V_{IH}$	—		$0.7 V_{DD}$	—	$V_{DD}$	V
	$V_{IL}$	—		GND	—	$0.3 V_{DD}$	
SOUT terminal	$V_{OL}$	$I_{OH} = 1.0\text{ mA}$ , $V_{DD} = 3.3\text{ V}$		—	—	0.3	V
		$I_{OH} = 1.0\text{ mA}$ , $V_{DD} = 5\text{ V}$		—	—	0.3	
Output voltage	$V_{OH}$	$I_{OL} = -1.0\text{ mA}$ , $V_{DD} = 3.3\text{ V}$		3	—	—	V
		$I_{OH} = 1.0\text{ mA}$ , $V_{DD} = 5\text{ V}$		4.7	—	—	
Output current Supply voltage Regulation	$\%V_{DD}$	$V_{DD} = 3\text{ V} \rightarrow 5.5\text{ V}$		—	$\pm 1.5$	$\pm 5.0$	%
Pull-up resistor	$R_{(Up)}$	$\overline{\text{ENABLE}}$ terminal		100	200	400	$\text{k}\Omega$
Pull-down resistor	$R_{(Down)}$	$\overline{\text{LATCH}}$ terminal		125	250	500	$\text{k}\Omega$
Supply current	$I_{DD(OFF)1}$	$V_{OUT} = 15.0\text{ V}$	$R_{EXT} = \text{OPEN}$	—	0.1	0.5	mA
	$I_{DD(OFF)2}$	$V_{OUT} = 15.0\text{ V}$ , All outputs OFF	$R_{EXT} = 490\ \Omega$	1	3	5	
	$I_{DD(OFF)3}$	$V_{OUT} = 15.0\text{ V}$ , All outputs OFF	$R_{EXT} = 250\ \Omega$	3	6	8	
	$I_{DD(ON)1}$	$V_{OUT} = 0.7\text{ V}$ , All outputs ON	$R_{EXT} = 490\ \Omega$	—	6	9	
		Same as the above, $T_{opr} = -40^\circ\text{C}$		—	—	15	
	$I_{DD(ON)2}$	$V_{OUT} = 0.7\text{ V}$ , All outputs ON	$R_{EXT} = 250\ \Omega$	—	12	17	
Same as the above, $T_{opr} = -40^\circ\text{C}$		—		—	29		

## Switching Characteristics (T<sub>opr</sub> = 25°C unless otherwise specified)

Characteristics	Symbol	Test Condition	Min	Typ.	Max	Unit
Propagation delay time	t <sub>pLH1</sub>	CLK to $\overline{\text{OUT}}_n$ , $\overline{\text{LATCH}} = \text{"H"}$ , $\overline{\text{ENABLE}} = \text{"L"}$	—	150	300	ns
	t <sub>pLH2</sub>	$\overline{\text{LATCH}}$ to $\overline{\text{OUT}}_n$ , $\overline{\text{ENABLE}} = \text{"L"}$	—	140	300	
	t <sub>pLH3</sub>	$\overline{\text{ENABLE}}$ to $\overline{\text{OUT}}_n$ , $\overline{\text{LATCH}} = \text{"H"}$	—	140	300	
	t <sub>pLH</sub>	CLK to SERIAL OUT	2	5	—	
	t <sub>pHL1</sub>	CLK to $\overline{\text{OUT}}_n$ , $\overline{\text{LATCH}} = \text{"H"}$ , $\overline{\text{ENABLE}} = \text{"L"}$	—	170	340	
	t <sub>pHL2</sub>	$\overline{\text{LATCH}}$ to $\overline{\text{OUT}}_n$ , $\overline{\text{ENABLE}} = \text{"L"}$	—	170	340	
	t <sub>pHL3</sub>	$\overline{\text{ENABLE}}$ to $\overline{\text{OUT}}_n$ , $\overline{\text{LATCH}} = \text{"H"}$	—	170	340	
	t <sub>pHL</sub>	CLK to SERIAL OUT	2	5	—	
Output rise time	t <sub>or</sub>	10 to 90% of voltage waveform	40	85	150	ns
Output fall time	t <sub>of</sub>	90 to 10% of voltage waveform	40	70	150	ns
Maximum clock rise time	t <sub>r</sub>	Cascade connection isn't guarantee. (Note 5)	—	—	5	us
Maximum clock fall time	t <sub>f</sub>		—	—	5	us

Conditions: (refer to test circuit.)

T<sub>opr</sub> = 25°C, V<sub>DD</sub> = V<sub>IH</sub> = 5 V, V<sub>OUT</sub> = 0.7 V, V<sub>IL</sub> = 0 V, R<sub>EXT</sub> = 490 Ω, V<sub>L</sub> = 5.0 V, R<sub>L</sub> = 100 Ω, C<sub>L</sub> = 10.5 pF

Note 5: If the device is connected in a cascade and t<sub>r</sub>/t<sub>f</sub> for the waveform is large, it may not be possible to achieve the timing required for data transfer. Please consider the timings carefully.

## Test Circuit

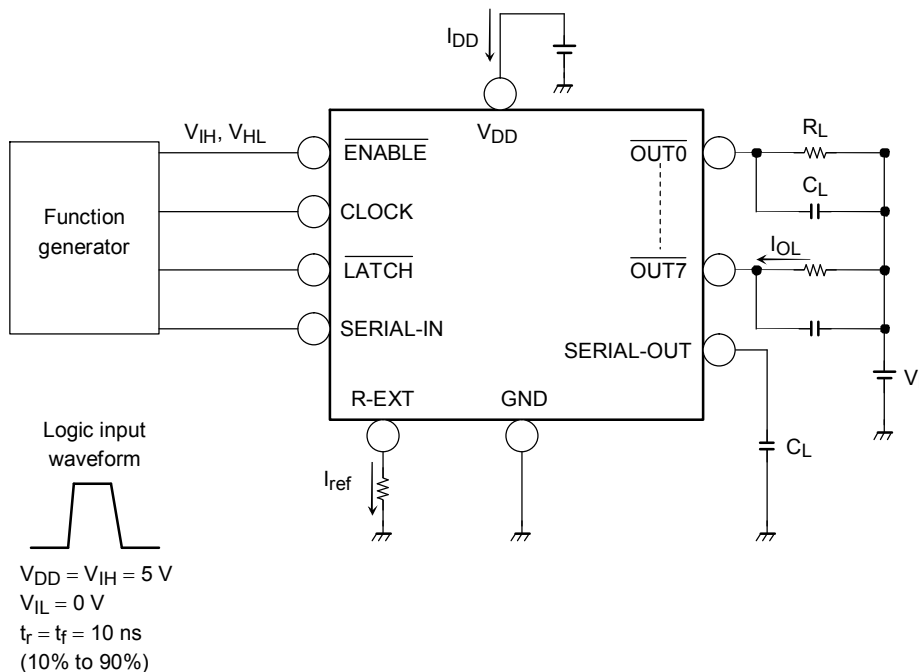

## Timing Waveforms

### 1. CLOCK, SERIAL-IN, SERIAL-OUT

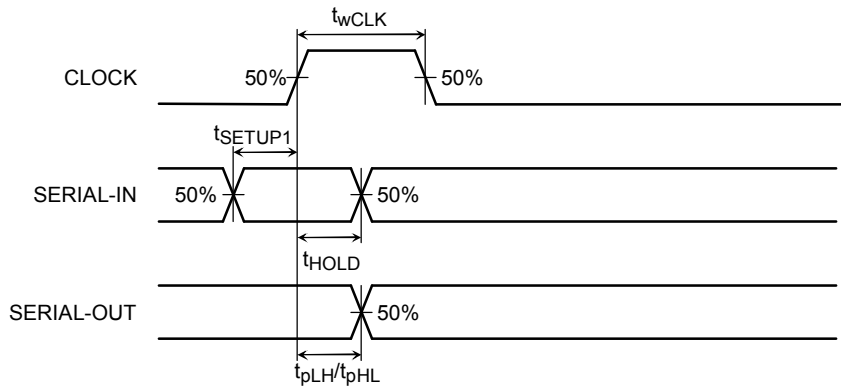

### 2. CLOCK, SERIAL-IN, $\overline{LATCH}$ , $\overline{ENABLE}$ , $\overline{OUTn}$

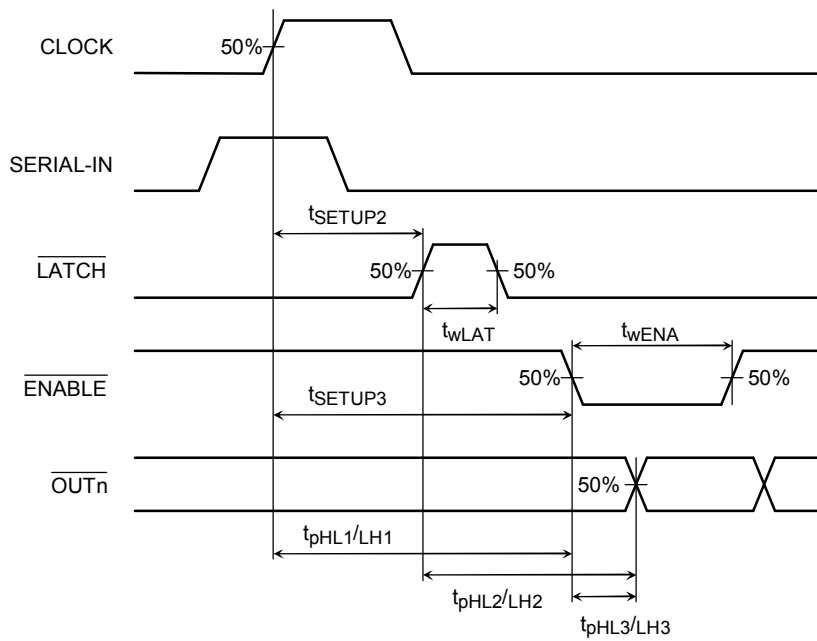

### 3. $\overline{OUTn}$

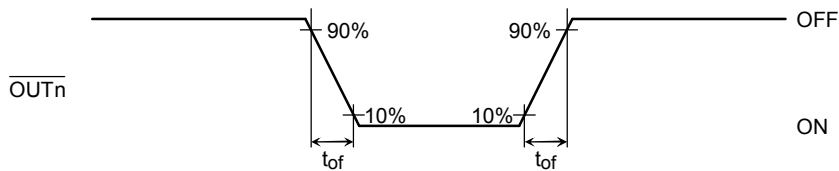

## Output Current – Duty (LED turn-on rate)

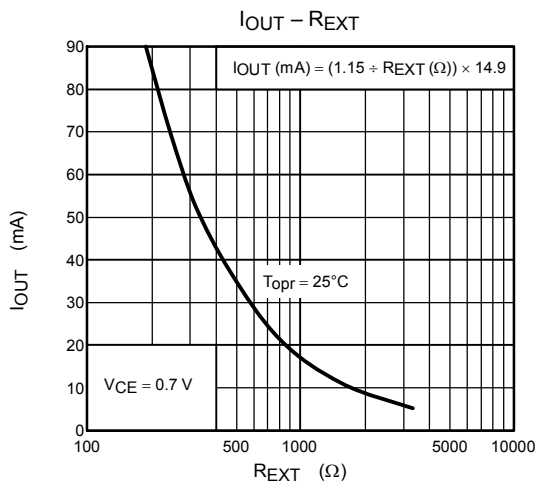
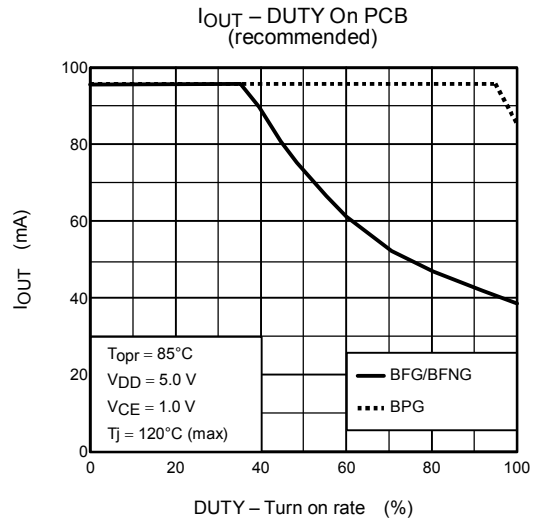
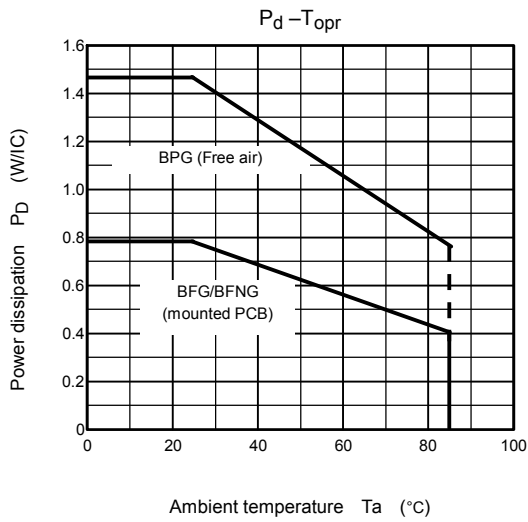
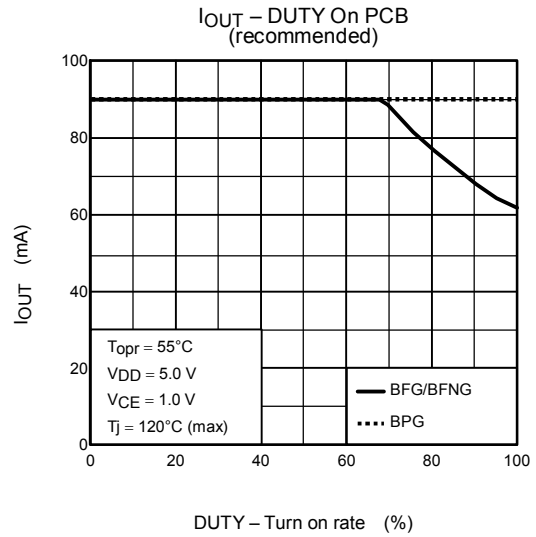
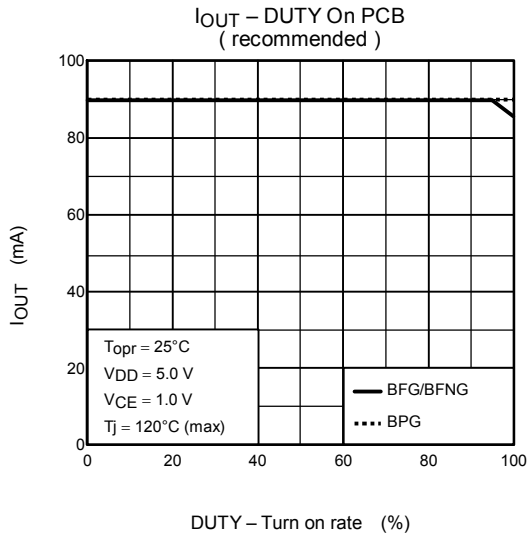

# TOSHIBA

## Application Circuit (example 1): The general composition in static lighting of LED.

More than  $V_{LED} (V) \geq V_f (\text{total max}) + 0.7$  is recommended with the following application circuit with the LED power supply  $V_{LED}$ .  
 r1: The setup resistance for the setup of output current of every IC.  
 r2: The variable resistance for the brightness control of every LED module.

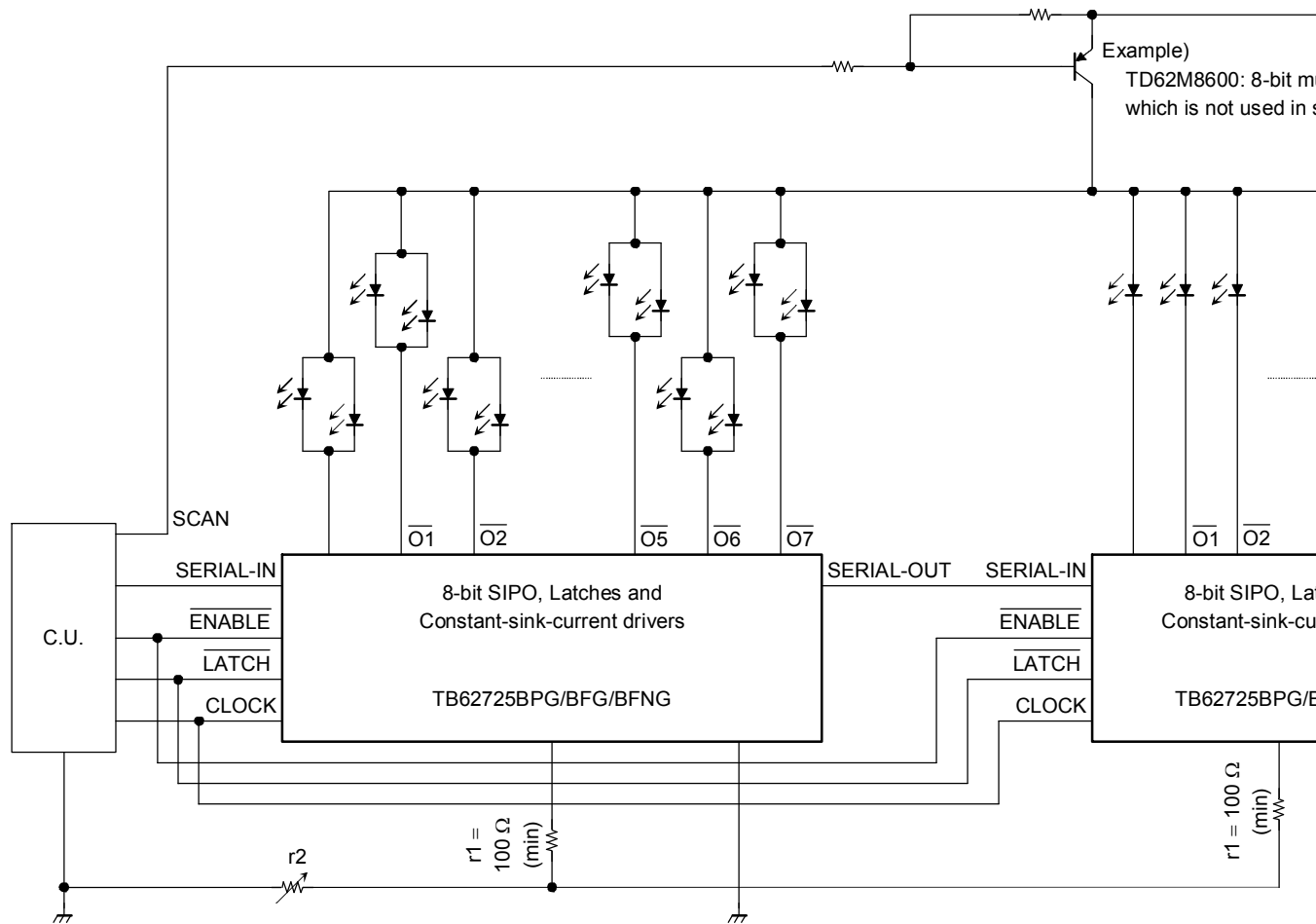

# TOSHIBA

## Application Circuit (example 2): When the condition of $V_{LED}$ is $V_{LED} > 17\text{ V}$ .

The unnecessary voltage is one effective technique as to making the voltage descend with the zennor diode.

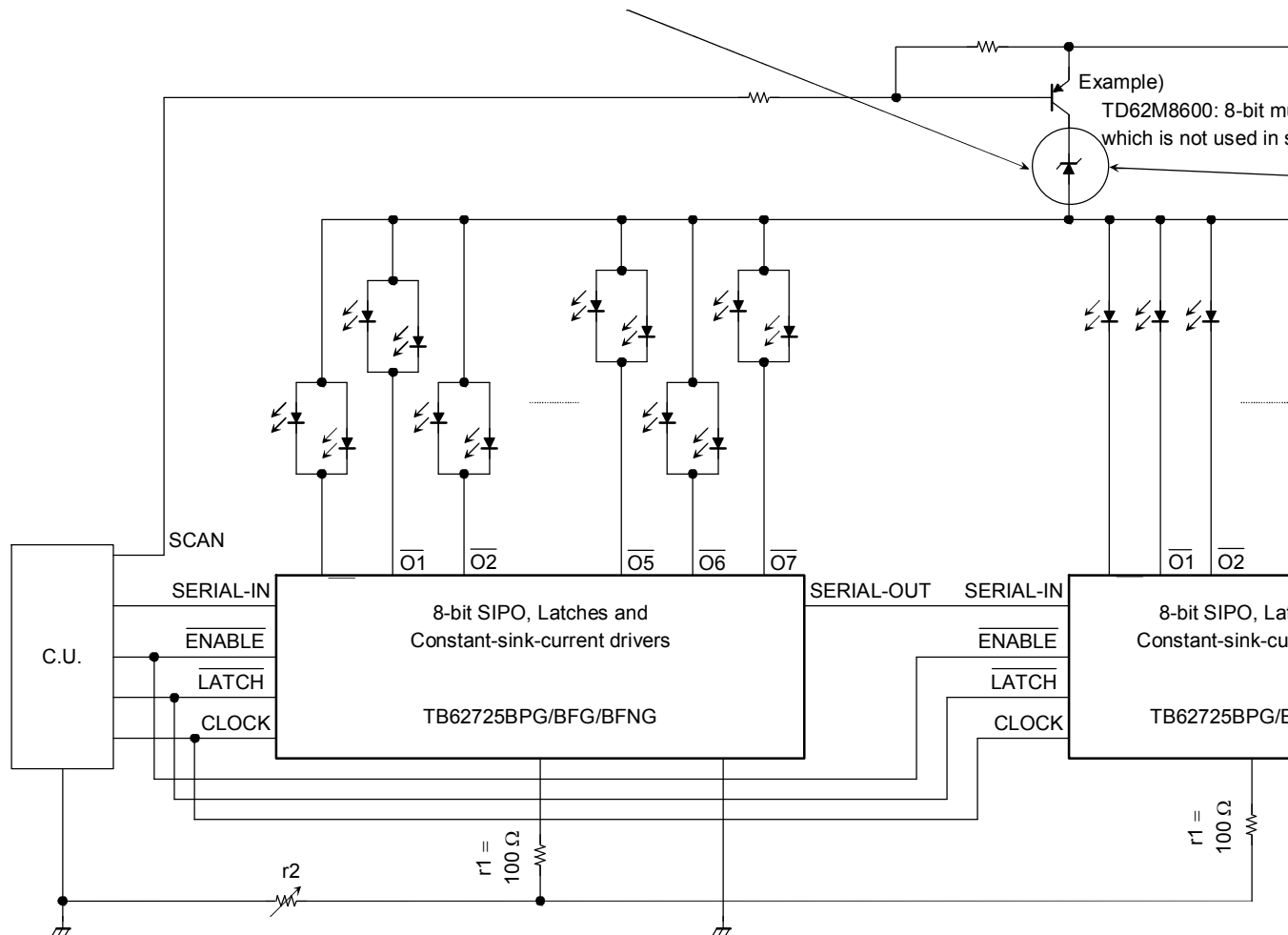

# TOSHIBA

## Application Circuit (example 3): When the condition of $V_{LED}$ is $V_f + 0.7 < V_{LED} < 17 V$ .

$V_{OUT} = V_{LED} - V_f = 0.7$  to  $1.0 V$  is the most suitable for  $V_{OUT}$ .

Surplus  $V_{OUT}$  causes an IC fever and the useless consumption electric power.

It is the one way of being effective to build in the  $r3$  in this problem.

$r3$  can make a calculation to the formula  $r3$  (ohms) = surplus  $V_{OUT}/I_{OUT}$ .

Though the resistance parts increase, the fixed constant current performance is kept.

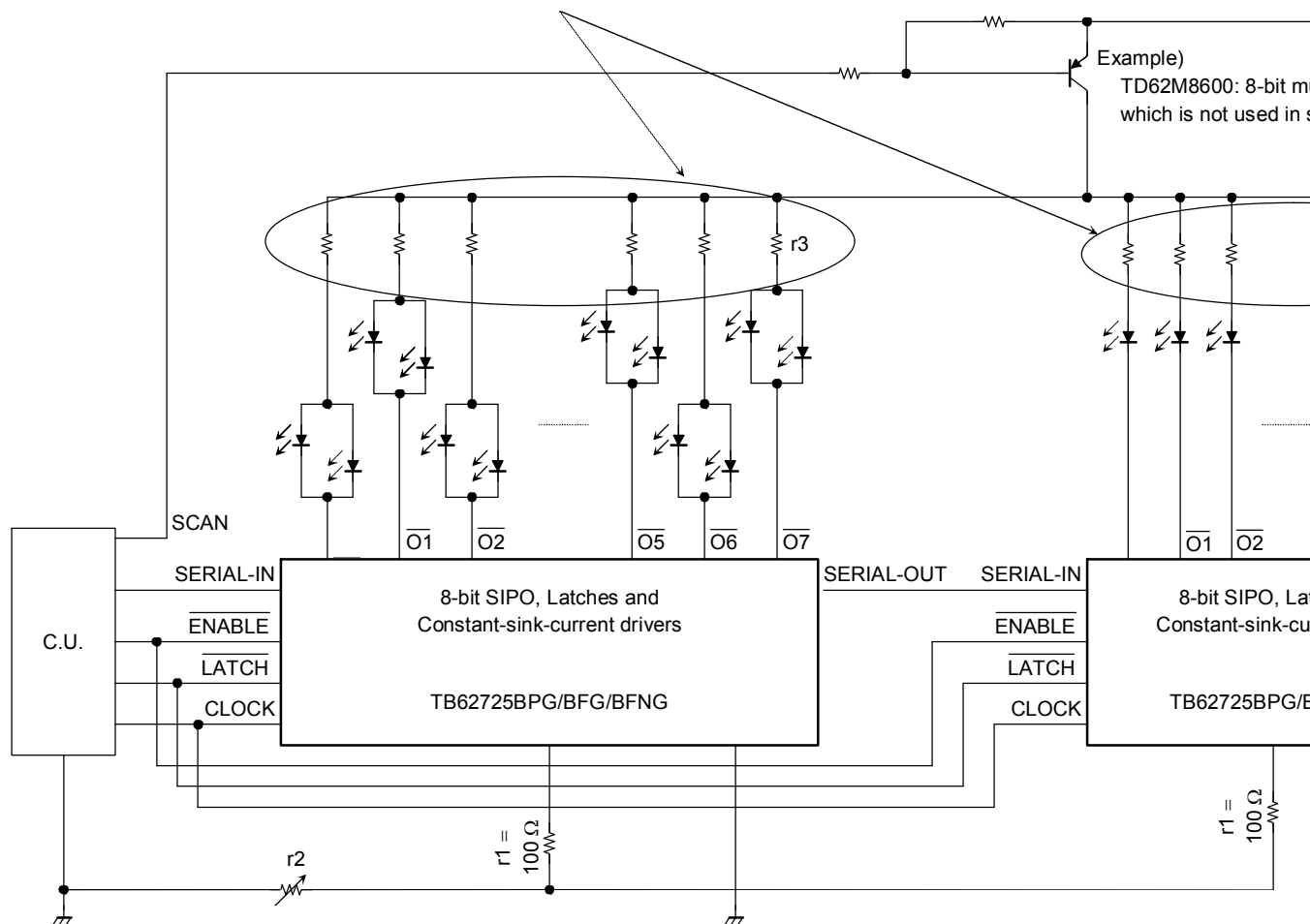

**Notes**

Operation may become unstable due to the electromagnetic interference caused by the wiring and other phenomena.

To counter this, it is recommended that the IC be situated as close as possible to the LED module.

If overvoltage is caused by inductance between the LED and the output terminals, both the LED and the terminals may suffer damage as a result.

There is only one GND terminal on this device when the inductance in the GND line and the resistor are large, the device may malfunction due to the GND noise when output switching by the circuit board pattern and wiring.

To achieve stable operation, it is necessary to connect a resistor between the REXT terminal and the GND line.

Fluctuation in the output waveform is likely to occur when the GND line is unstable or when a capacitor (of more than 50 pF) is used.

Therefore, take care when designing the circuit board pattern layout and the wiring from the controller.

This application circuit is a reference example and is not guaranteed to work in all conditions.

Be sure to check the operation of your circuits.

This device does not include protection circuits for over voltage, over current or over temperature.

If protection is necessary, it must be incorporated into the control circuitry.

The device is likely to be destroyed if a short-circuit occurs between either of the power supply pins and any of the output terminals when designing circuits, pay special attention to the positions of the output terminals and the power supply terminals (VDD and VLED), and to the design of the GND line.

## Package Dimensions

DIP16-P-300-2.54A

Unit : mm

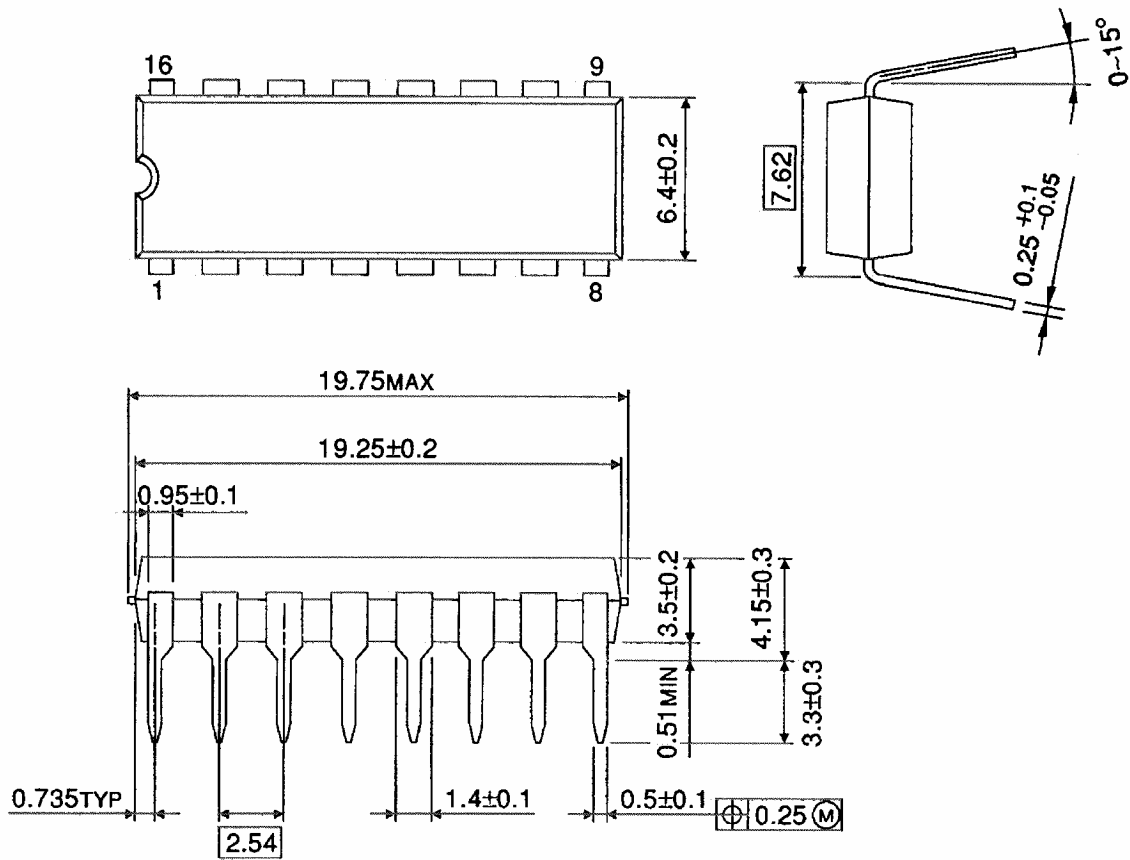

Weight: 1.11 g (typ.)

**Package Dimensions**

SSOP16-P-225-1.00A

Unit : mm

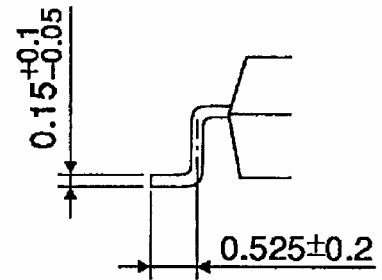
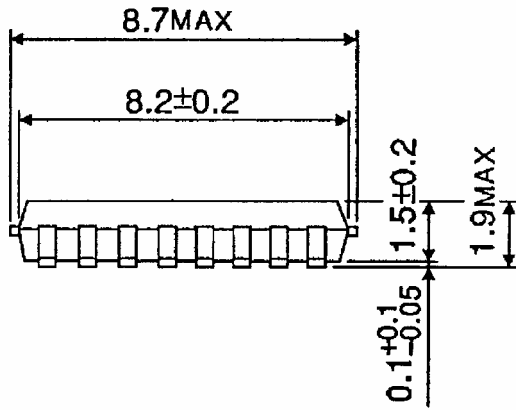
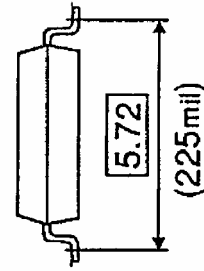
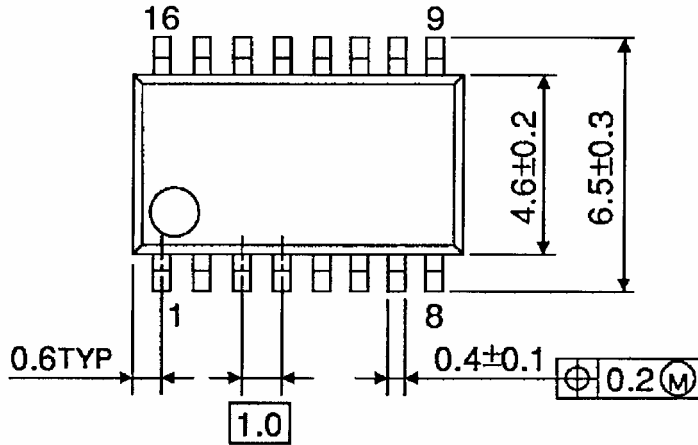

Weight: 0.14 g (typ.)

**Package Dimensions**

SSOP16-P-225-0.65B

Unit : mm

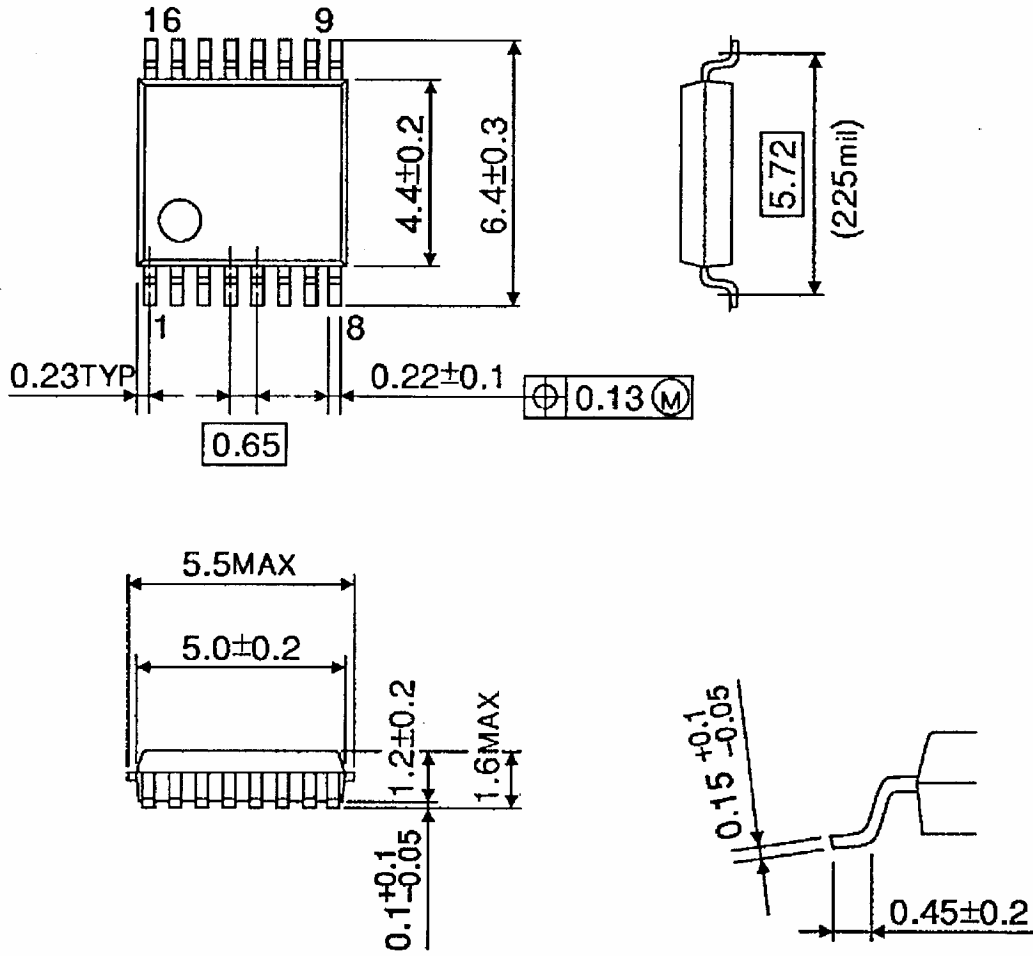

Weight: 0.07 g (typ.)

About solderability, following conditions were confirmed

#### Solderability

##### Use of Sn-63Pb solder Bath

- solder bath temperature = 230°C
- dipping time = 5 seconds
- the number of times = once
- use of R-type flux

##### Use of Sn-3.0Ag-0.5Cu solder Bath

- solder bath temperature = 245°C
- dipping time = 5 seconds
- the number of times = once
- use of R-type flux

## RESTRICTIONS ON PRODUCT USE

000707EBA

TOSHIBA is continually working to improve the quality and reliability of its products. Nevertheless, semiconductor devices in general can malfunction or fail due to their inherent electrical sensitivity and vulnerability to physical stress. It is the responsibility of the buyer, when utilizing TOSHIBA products, to comply with the standards of safety in making a safe design for the entire system, and to avoid situations in which a malfunction or failure of such TOSHIBA products could cause loss of human life, bodily injury or damage to property.

In developing your designs, please ensure that TOSHIBA products are used within specified operating ranges as set forth in the most recent TOSHIBA products specifications. Also, please keep in mind the precautions and conditions set forth in the "Handling Guide for Semiconductor Devices," or "TOSHIBA Semiconductor Reliability Handbook" etc..

The TOSHIBA products listed in this document are intended for usage in general electronics applications (computer, personal equipment, office equipment, measuring equipment, industrial robotics, domestic appliances, etc.). These TOSHIBA products are neither intended nor warranted for usage in equipment that requires extraordinarily high quality and/or reliability or a malfunction or failure of which may cause loss of human life or bodily injury ("Unintended Usage"). Unintended Usage include atomic energy control instruments, airplane or spaceship instruments, transportation instruments, traffic signal instruments, combustion control instruments, medical instruments, all types of safety devices, etc.. Unintended Usage of TOSHIBA products listed in this document shall be made at the customer's own risk.

The products described in this document are subject to the foreign exchange and foreign trade laws.

The information contained herein is presented only as a guide for the applications of our products. No responsibility is assumed by TOSHIBA CORPORATION for any infringements of intellectual property or other rights of the third parties which may result from its use. No license is granted by implication or otherwise under any intellectual property or other rights of TOSHIBA CORPORATION or others.

The information contained herein is subject to change without notice.