

15 Watt TC Single Series DC/DC Converters



Features

- -40° to +90°C Case Operating Range Standard
- Dual Stage Output Filter for Low Noise Operation
- Very Low OFF Current, 1 mA Typically
- Water Washable Design
- Five Year Warranty

Description

These single output DC/DC converters are designed to provide a wide range of PCB mount power solutions. The extra wide 3:1 input voltage range covers the common American and European telecom standards along with 24 volt industrial control applications.

For flexibility, a trim pin is included to adjust the output voltage. Use it to compensate for voltage drops in your system's wiring or to achieve non standard voltages. Use the remote ON/OFF function to maximize battery life.

The TC Single Series continues the CALEX tradition of reliable design by including transient overvoltage suppressor diode protection at the input and output terminals. Also provided as standard are overcurrent protection circuits. These features assure zero failure rate operation when using the TC Single Series.

Selection Chart				
MODEL	INPUT RANGE VDC		OUTPUT VDC	OUTPUT mA
	MIN	MAX		
*48S5.3000TC	20	60	5.0	3000
48S12.1250TC	20	60	12.0	1250
48S15.1000TC	20	60	15.0	1000

* Agency Approval: UL 1459

15 Watt TC Single Series Block Diagram

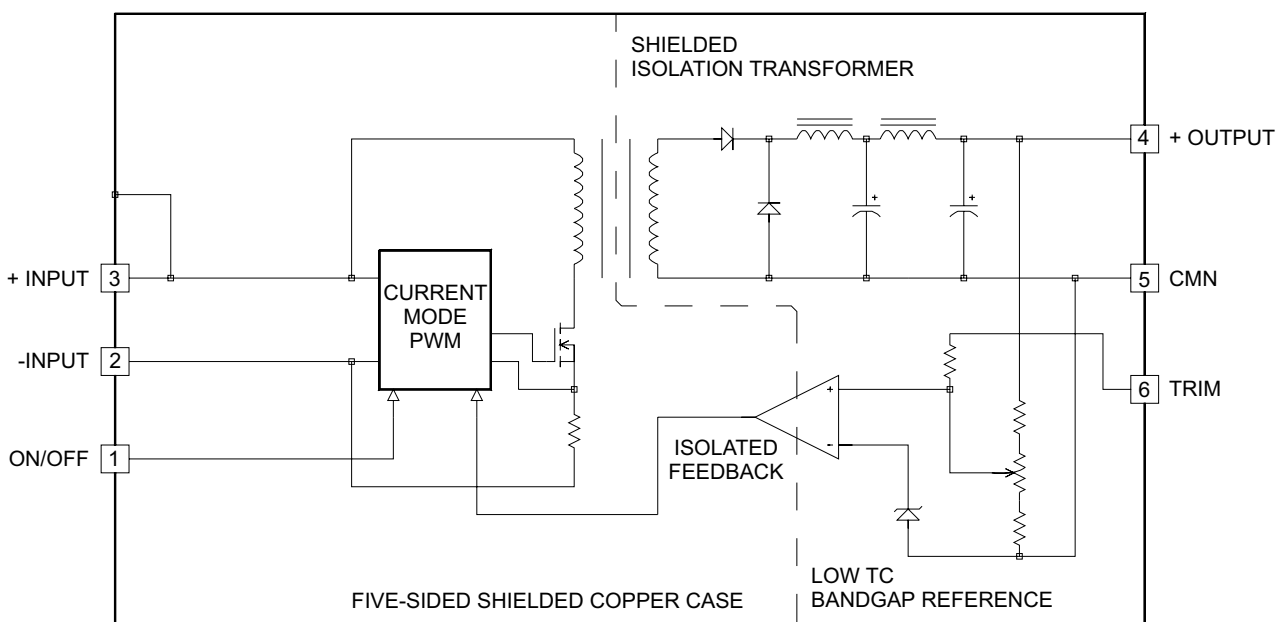

15 Watt TC Single Series DC/DC Converters

Input Parameters*					
Model		48S5.3000TC	48S12.1250TC	48S15.1000TC	Units
Voltage Range	MIN	20.0			VDC
	TYP	48.0			
	MAX	60.0			
Input Current Full Load	TYP	395	380	375	mA
	No Load	TYP	2	4	
Efficiency	TYP	79	82	83	%
Switching Frequency	TYP	120			kHz
Maximum Input Overvoltage, 100ms No Damage	MAX	75			VDC
Turn-on Time, 1% Output Error	TYP	5	10		ms
Recommended Fuse		(1)			

Output Parameters*					
Model		48S5.3000TC	48S12.1250TC	48S15.1000TC	Units
Output Voltage		5	12	15	VDC
Rated Load (3)	MIN	0	0	0	mA
	MAX	3000	1250	1000	
Voltage Range 100% Load	MIN	4.950	11.900	14.900	VDC
	TYP	5.000	12.000	15.000	
	MAX	5.050	12.100	15.100	
Load Regulation 25-100% Full Load	TYP	0.5	0.1	0.1	%
	MAX	0.75	0.2	0.2	
Line Regulation Vin = Min-Max VDC	TYP	0.1	0.01	0.01	%
	MAX	0.15	0.1	0.1	
Short Term Stability (4)	TYP	< 0.02			%/24Hrs
Long Term Stability	TYP	< 0.05			%/kHrs
Transient Response (5)	TYP	100	600	200	µs
Dynamic Response (6)	TYP	150	200	170	mV peak
Input Ripple Rejection (7)	TYP	> 60			dB
Noise, 0-20MHz bw (2)	TYP	75	60	60	mV P-P
RMS Noise	TYP	3	2	2	mV RMS
Temperature Coefficient	TYP	50			ppm/°C
	MAX	150			
Short Circuit Protection to Common for all Outputs		Current Limit			

NOTES

* All Parameters measured at Tc=25°C, nominal input voltage and full rated load unless otherwise noted. Refer to the CALEX Application Notes for the definition of terms, measurement circuits and other information.

- (1) See our application note for picking the correct fuse size.
- (2) Noise is measured per CALEX Application Notes. Measurement bandwidth is 0-20 MHz. RMS noise is measured over a 0.01-1 MHz bandwidth. To simulate standard PCB decoupling practices, output noise is measured with a 0.1µF, ceramic capacitor located 1 inch away from the converter.
- (3) Minimum load required for rated regulation only. Dynamic response may degrade if run at less than 25% full load.
- (4) Short term stability is specified after a 30 minute warm-up at full load, and with constant line, load and ambient conditions.

- (5) The transient response is specified as the time required to settle from a 50 to 75% step load change (rise time of step = 2µSec) to a 1% error band.
- (6) Dynamic response is the peak overshoot voltage during the transient response time defined in note 5.
- (7) The input ripple rejection is specified for DC to 120Hz ripple with a modulation amplitude of 1% Vin.
- (8) The ON/OFF pin is Open Collector TTL, CMOS, and relay compatible. The input to this pin is referenced to Pin 2 (-Input) and is protected to +75VDC.
- (9) Case is tied to Pin 3, +Input.
- (10) The case thermal impedance is specified as the case temperature rise over ambient per package watt dissipated.
- (11) Specifications subject to change without notice.

15 Watt TC Single Series DC/DC Converters

General Specifications*			
All Models			Units
ON/OFF Function (8)			
ON Logic Level or Leave Pin Open	MIN	8.0	VDC
OFF Logic Level	MAX	2.0	VDC
Input Resistance	TYP	100	kohms
Converter Idle Current, ON/OFF Pin Low	TYP	<1	mA
Isolation (9)			
Isolation Voltage 10µA Leakage Input-Output	MIN	700	VDC
Input to Output Capacitance	TYP	300	pF
Output Trim Function			
Input Resistance	TYP	20	kohms
Programming Range	MIN	±5	%
Environmental			
Case Operating Range No Derating	MIN MAX	-40 90	°C
Storage Range	MIN MAX	-55 100	°C
Thermal Impedance (10)	TYP	10	°C/Watt
General			
Unit Weight	TYP	2	oz
Chassis Mounting Kit		MS8	

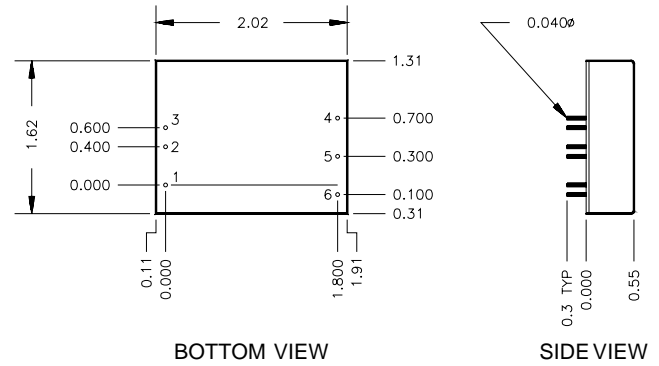

Mechanical tolerances unless otherwise noted:

X.XX dimensions: ±0.020 inches

X.XXX dimensions: ±0.005 inches

Seal around terminals is not hermetic. Do not immerse units in any liquid.

Pin	Function
1	ON/OFF
2	-INPUT
3	+INPUT
4	+OUTPUT
5	CMN
6	TRIM

15 Watt TC Single Typical Application

Figure 1 shows the recommended connections for the 15 Watt TC Singles. Capacitor C1 is required for proper operation (see below). The trim and ON/OFF pins can be safely left floating if they are not used. The input fuse should not be omitted.

The fuse serves two purposes:

- 1) It prevents unlimited current from flowing in the case of a catastrophic system failure
- 2) UL regulations for telecom equipment require the use of a fuse. See CALEX Application Notes for more info on sizing the input fuse.

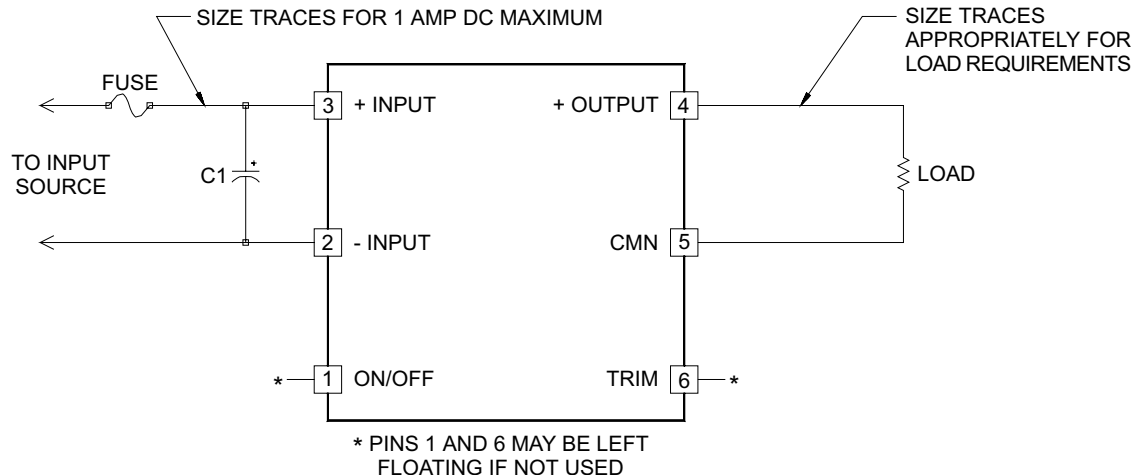

FIGURE 1.

Recommended application circuit for TC Single Series

15 Watt TC Single Series DC/DC Converters

Sizing The Input Capacitor

For maximum reliability the TC Single Series must use a capacitor of sufficient ripple handling capability connected across the input pins. The probable result of undersizing (over stressing) this capacitor is increased self heating, shortening of the capacitors and hence shortening of your systems' life. Oversizing the capacitor can have a negative effect on your product's cost and size, although this kind of overdesign does not result in shorter life of any components. There is no one optimum value for this capacitor. The size and capacity are dependent on the following factors:

- 1) expected ambient temperature and your temperature derating guidelines
- 2) your ripple current derating guidelines
- 3) the maximum load expected on the converter
- 4) the minimum input voltage expected on the converter
- 5) the statistical probability that your system will spend a significant amount of time at any worst case extreme

Factors 1 and 2 are determined by your system design guidelines. These can range from 50% to 100% of the manufacturer's rated maximum, although a usual derating factor is 70% of manufacturer's maximum limit. 70% derating means that if the capacitor manufacturer says their capacitor can do 1 A RMS and 100 VDC you would not use the part over 700 mA RMS and 70 VDC. Surge voltage rating should also be evaluated against any expected voltage surges when selecting a capacitor working voltage.

Factors 3 and 4 realistically determine the worst case ripple current. The reflected ripple current increases with output load and increases as the input voltage decreases. So if you are running with a solid 48 VDC input and at 50% load your capacitors required ripple current rating would decrease by more than 2:1 from what would be required for operation at 20 VDC with full load (see the "Input Reflected Ripple" curve).

Factor 5 is not easy to quantify. At CALEX, we can make no assumptions about a customer's system so we design for continuous operation at worst case extremes.

Example Of Capacitor Sizing

Given the following conditions, select the minimum size capacitor needed to provide reliable performance:

Converter	48S5.3000TC
Minimum Input Voltage	40 VDC
Maximum Input Voltage	52 VDC
Maximum Load	2.25 Amps
Maximum Ambient Temperature	40°C
Your Capacitor Voltage Derating Guideline	70% of Maximum Specification
Your Capacitor Current Derating Guideline	70% of Maximum Specification

Solution

According to the 15 Watt TC Single Series "Reflected Input Ripple vs. Line Input" curve at 40 VDC input and 2.25 Amps output (75% of rated load), the reflected input ripple can be read as 650 mA RMS. From the derating guidelines the capacitor's rated voltage and ripple current can be determined.

Capacitor voltage rating is calculated as:

$$V = \frac{1}{\text{Voltage Derating Factor}} \times \text{Maximum Expected Input}$$

$$V = \frac{1}{0.7} \times 52 = 74 \text{ Volts or greater}$$

$$I = \frac{1}{\text{Current Derating Factor}} \times \text{Reflected Ripple}$$

$$= \frac{1}{0.7} \times 650 \text{ mA} = 0.93 \text{ A RMS or greater at } 45^\circ\text{C}$$

(40°C ambient + 5°C for self heating)

A capacitor selection can now be made. Look only at controlled low ESR types (where the ESR is specified as a maximum) because these usually have the highest ripple current capability per unit volume.

Be careful to compare apples to apples. Some manufacturers specify their capacitors at 85°C and others specify at 105°C. The manufacturers give temperature derating guidelines, so all capacitors should be normalized to your maximum ambient (plus 5°C to account for self heating) before making a selection. Since the 15 Watt TC Single Series operates at 120 kHz the frequency usually does not have to be derated since most modern low ESR capacitors are rated at 100 kHz.

One note: The temperature derating multipliers are based on the capacitor's expected life at 105°C. The life of a capacitor operating at a significantly lower temperature will not be greater if the ripple current in the part is increased over the 105°C rating. This means that a capacitor rated for 1 A RMS current at 105°C and 2 A RMS at 50°C will have the same life if used at either point while the same capacitor used at 1 A RMS and 50°C will have a longer life.

Suggested Capacitor Sources

Suitable capacitors can be acquired from the following sources:

United Chemi-Con	SXE, RXC, RZ and RZA Series
Suggested Part:	SXE100VB221M12.5X35LL
	220µF, 100V, 105°C Rated
	ESR=0.087 ohms
	Allowable Ripple=1.45 A @ 105°C
Nichicon	PR and PF
Suggested Part:	UPR2A102MPH
	1000µF, 100V, 105°C Rated
	ESR=0.047 ohms
	Allowable Ripple=1.32 A @ 105°C

15 Watt TC Single Series DC/DC Converters

Panasonic HFE Series
 Suggested Part: ECEA2AFE221L
 220 μ F, 100V, 105°C Rated
 ESR=0.089 ohms
 Allowable Ripple=1.04 A @ 105°C

The suggested capacitors will work for any line and load condition, however, they may be oversized for your application.

Low Noise Input Filtering Circuit

To reduce the input reflected ripple to less than 50 mA peak to peak the circuit shown in Figure 2 may be used. Toroid core inductors have theoretically lower radiated noise than a rod core. Use reasonable caution when selecting an inductor other than the one specified. Nearly any 105°C rated capacitor can be used for the 10 μ F / 100V part. To prevent input filter peaking the ESR should be in the range of 0.5 to 2 ohms. Do not use the lowest ESR capacitor available for this part. This will render the filter ineffective.

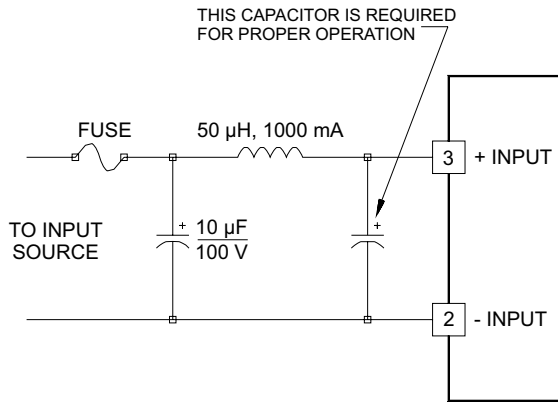

FIGURE 2. Low noise input filter circuit

Remote ON/OFF Circuit Operation

The remote ON/OFF pin is best applied as follows:

- To turn the unit off, the ON/OFF pin should be tied to the - Input pin. This is best done by an open collector arrangement or contact closure.
- To turn the unit on, let the ON/OFF pin float.
- If the remote ON/OFF pin is not used, it may be safely left floating. There is a 100K internal pull-up resistor inside the unit to +9 volts DC.

Other applications of the ON/OFF function can be found in the application note, "Understanding the Remote ON/OFF Function".

Proper Application Of The Trim Pin

The trim pin is used to adjust the output voltage slightly to compensate for voltage drops in the system's wiring. Figure 3 shows the proper application of the trim pin. Either a 10K trimpot or fixed resistors may be used.

Other applications for the TRIM function can be found in the CALEX application note: "Applying the Remote Sense and Trim Functions on DC/DC Converters."

Use one resistor for either trim up or trim down. The values can range from infinity to zero ohms with zero ohms providing the most trim.

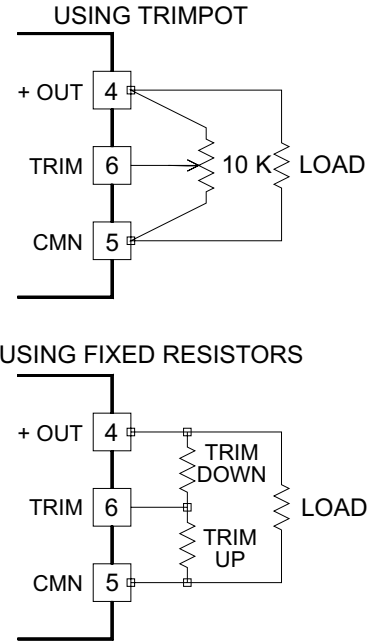

Figure 3. Output trim methods

Temperature Derating Guidelines

Care must be taken in the application of all power devices. Be sure to account for the self heating in your instrument due to the power converter and the loads. For minimum temperature gradient, the hottest components should be mounted at the bottom of your system (bottom of a vertical PCB) and the coolest components at the top of the system. This will help to even the temperature of the entire system and prevent temperature gradients.

The 15 Watt TC Single Series has a thermal impedance of 10°C per package watt dissipated. During normal operation the 15 Watt TC Single Series can be expected to run at 80% efficiency at 48 VDC and full load. This means that the 15 Watt TC Single Series is dissipating nearly 4 Watts internally at full load. This, therefore, translates to a package temperature rise of about 40°C (10°C/watt x 4 watts dissipated).

The maximum rated case temperature for the 15 Watt TC Series is 90°C. This means that, in the absence of other heat sources (including the load that the converter is powering) and with at least 3 inches of clearance, the 15 Watt TC Single Series can be expected to operate at an ambient of 50°C.

Additional heat sinks or cooling air flow can extend the ambient temperature of operation significantly.

15 Watt TC Single Series DC/DC Converters

Typical Performance ($T_c=25^\circ\text{C}$, $V_{in}=\text{Nom VDC}$, Rated Load, 48S12.1250TC)

