



Plasma Panel Display Modules

240 x 64 Graphics Display with ASCII Input Controller,
DC/DC Converter and Drive Circuitry



The APD-240G064 is a dot matrix graphic display with an array of 240 x 64 pixels available. The module is composed of a highly reliable DC plasma display, ASCII input graphics controller, DC converter and drive circuitry which are assembled to form a rugged, slim profile display sub-system.

Interface to the APD-240G064 is through a parallel or serial interface. The interface allows for efficient handshaking and flow of bi-directional data. Vishay Dale's patented open construction display technology assures a stable, flicker free screen.

ENVIRONMENTAL SPECIFICATIONS

- Operating Temperature:** 0°C to - 70°C
- Storage Temperature:** - 20°C to - 85°C
- Operating Humidity:** 95% RH non-condensing
- Mechanical Shock:** 30G
- Vibration:** 0.018" [.457mm] displacement amplitude from 10-50Hz, 2G acceleration from 50 to 2000Hz logarithmic sweep rate
- Mean Time Between Failure:** 50,000 hours

ELECTROSTATIC CAUTION

Vishay Dale display panels use electrostatic sensitive components. These assemblies should be unpacked and handled in an ESD controlled area only. When shipping use packing materials designed for protection of electrostatic sensitive components. Vishay Dale believes that the information described in this publication is accurate and reliable, and much care has been taken in its preparation. However, no responsibility, financial or otherwise, is accepted for any consequences arising out of the use of this information.

This information is subject to change without notice.

FEATURES

- 240 x 64 pixel array for bright and vivid graphics
- Parallel interface or RS-232 serial interface
- Powerful software commands make display integration simple and efficient
- + 5 to + 24VDC display voltage

STANDARD ELECTRICAL SPECIFICATIONS

DESCRIPTION	SYMBOL	MIN.	TYP.	MAX.	UNITS
Panel Supply Voltage	VDC	5	12.0	24	V
Panel Supply Current	IDC*	—	1.25	2.50**	A

Note: *at 12V **at start-up

OPTICAL SPECIFICATIONS

- Pixel Size:** .019" [.483mm]
- Pixel Array:** 240 x 64
- Luminance:** 50 foot lamberts typical
- Color:** Neon orange.
- Refresh Cycle:** 65Hz
- Viewing Angle:** 150° cone
- Contrast Ratio:** 30:1

DIMENSIONS in inches

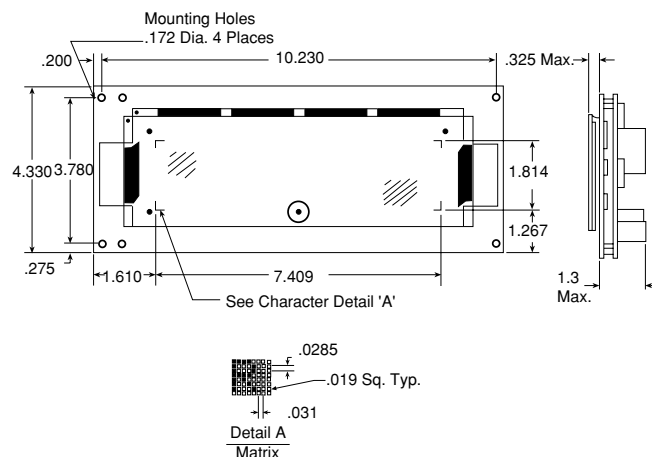

APD-240G064



Vishay Dale

POWER SUPPLY: (Recommended)		
VDC	+ 12V ± 0.6V	2.5A Max.*, 1.25 A Typ.

***Note:** The maximum VDC draw denotes a power up condition when the DC converter starts. Typical duration is 15-30 mS.

*Unit may be powered from + 5V to + 24V. Contact factory for current draw at voltages other than + 12V and pin connection J2.

POWER UP CONDITION

Immediately upon power up the following is set:

The module is in the text mode.

The screen will have a message printed as follows:

RAM OK ROM OK
mm-dd-yy

This message indicates the hardware test has passed successfully. The "mm-dd-yy" indicates the date the firmware was released.

POWER SUPPLY CONNECTION		
CONNECTOR	PIN	SIGNAL
J1	1	+ 12 V
	2	GROUND
	3	GROUND
	4	Reserved

Mates to Tyco AMP *1-480424-0 housing (1 rqr.)
*350689-1 socket pins (4 rqr.)

Power up RESET cycle on display module takes approximately 250 mS to complete. It is suggested the user wait for that time period to elapse before entering data.

PARALLEL INTERFACE

J2, PARALLEL DATA CONNECTOR.

Mates with 3M Tyco AMP 746285-6, 26 pin, IDC connector.

Note: PAR should be jumper selected on jumper block W1 for proper parallel interface operation.

PARALLEL INTERFACE		
PIN	FUNCTION	DESCRIPTION
1, 3, 5, 7, 9, 11, 13, 15	D0-D7 (Data Bus) (input/output)	Data written to and read from the display unit through an 8 bit bi-directional data bus.
17	WRITE (WR) (input)	Write data on low to high transmit.
21	READ (RD) (input)	Read data while low.
6, 8, 12, 14, 16, 18, 20, 22	N/C	Not connected.
23	RESET (input)	Reset display to power-up condition when low, operate while high.
19	US (Unit Select) (input)	Read and Write commands only influence display while US is low.
25	BLANK (BL) (input)	Blank display while BL is low but maintain cursor and data.
4	BRIGHT/DIM (input)	Display at full brightness when high or half brightness when low.
24	(BUSY (BU) (output)	When BUSY is high, no further data or commands should be given.
2, 26	GROUND	Common to both power supply input and host data interface
10	DATA PRESENT (DP) (output)	Data is ready to be read when the DATA PRESENT signal is high.

INPUT/OUTPUT TIMING DIAGRAM, J2					
BU	DP	WR	RD	US	FUNCTION
L	X		H	L	Write character or control code.
X	H	H	L	L	Read data from display while low.
X	X	X	X	H	Input/Output inhibited.
LOGIC LEVEL: L = 0.0 V minimum to 0.8 V maximum. H = 2.2 V minimum to 5.0 V maximum.. X = Don't care.					

Note: Input load is one 74 HCT type input with 4.7k to V_{cc} . Outputs are 74 HC type.

Once data write is complete, BUSY signal is output. BUSY signal = "1" during data disposition and while the communication buffer is full.

DATA WRITE: When WR changes from "0" to "1" while US = "0" and RD = "1", data is latched.

DATA READ: When RD = "0" while US = "0". WR = "1", and DP = "1", data may be read by the host.



INTERFACING

W1 JUMPER

Shunt 1 pair of pins only on jumper W1 to select serial interface baud rate, parallel interface operation, or self-test functions. Shunt both OPT 1 and STEST to run demo.

	SELECTS		
1.2	<input type="radio"/>	<input type="radio"/>	1200 Baud
2.4	<input type="radio"/>	<input type="radio"/>	2400 Baud
4.8	<input type="radio"/>	<input type="radio"/>	4800 Baud
9.6	<input checked="" type="radio"/>	<input type="radio"/>	9600 Baud (Factory setting)
19.2	<input type="radio"/>	<input type="radio"/>	19200 Baud
OPT 1	<input type="radio"/>	<input type="radio"/>	Self-Test demo
PAR	<input type="radio"/>	<input type="radio"/>	Parallel Interface Operation
S TEST	<input type="radio"/>	<input type="radio"/>	Graphics Self-Test demo

W2 JUMPER

The W2 jumper selects the serial handshake busy line from the host computer to the display for control of data flow from the display. On Jumper W2, select "CTS" for host RTS to display CTS handshaking, or "DSR" for host DTR to display DSR handshaking. Selection does not affect parallel interface operation.

DSR

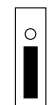

CTS

SELECTS

Host DTR to display DSR handshaking
 Host RTS to display CTS handshaking (factory setting)

SERIAL INTERFACE

J3, SERIAL INTERFACE CONNECTOR.

Serial interface, mates with Tyco AMP 10-pin IDC type 746285 -1 or equivalent. Female db-9 connector option available. The baud rate is jumper selected at jumper block W1 for 1200, 2400, 4800, 9600 or 19.2K baud.

SERIAL INTERFACE PIN CONNECTIONS					
DISPLAY CONNECTOR J3			HOST CONNECTION		
10-PIN	db-9	DESCRIPTION	db-9	db-25	DESCRIPTION
1	1	n/c (reserved)	—	—	—
2	6	n/c (reserved)	—	—	—
3	2	TxD (output)	2	3	RxD
4	7	CTS (input)	7	4	RTS
5	3	RxD (input)	3	2	TxD
6	8	RTS (output)	8	5	CTS
7	4	DSR (input)	4	20	DTR
8	9	n/c (reserved)	—	—	—
9	5	GND	5	7	GND
10	—	n/c (reserved)	—	—	—



COMMAND SET, TEXT MODE

(SOFTWARE INSTRUCTIONS)

The ASCII control code characters from 00h to 1Fh are reserved by the controller for the command interpreter. A brief listing of the available commands and their description follows.

HEX CODE	NUMBER OF BYTES	TEXT FUNCTIONS
00-07	1	NO FUNCTION.
08	1	BACK SPACE CURSOR: Moves the cursor 1 column to the left in the current row. If the cursor is at the 1st column it will move to the end of the previous line.
09	1	HORIZONTAL TAB: Moves the cursor 1 column to the right. Will wrap around at the end of the screen. If mode is set to SCROLL, the screen will scroll up one line at the last character position of the last row, if not in SCROLL mode, the cursor will wrap to the HOME position.
0A	1	LINE FEED: Moves cursor down one row while remaining in same column position. If mode is set to SCROLL, and the cursor is at bottom row of screen, the screen will move (scroll) up 1 row and bottom row will be cleared (filled with spaces), when line feed is invoked. If not in SCROLL mode the cursor will wrap to the first row.
0B	1	VERTICAL TAB: Moves cursor up one row while remaining in the same column position. The cursor will wrap to the bottom row after the top row.
0C	1	CLEAR SCREEN: Fill the screen with blank characters, cursor moves to HOME position.
0D	1	CARRIAGE RETURN: Moves cursor to the first column of the present row.
0E	1	HOME CURSOR: Moves cursor to the 1st character position of the 1st row, the HOME position.
0F		NO OPERATION.
10		NO OPERATION.
11	3	POSITION CURSOR: Moves cursor to a specified column, row address depending upon next 2 bytes sent. The format is column, row.
12	2	SELECT CURSOR: Following byte selects cursor style * 01 = Blinking Underbar 02 = Non-Blinking Underbar 03 = Blinking Block 04 = Cursor not Visible
13		NO OPERATION.
14	2	SELECT CHARACTER FONT: Following byte selects one of 4 character generator fonts: * 00 = ASCII, standard and inverse 01 = International 02 = International and Katakana 03 = International and Cyrillic
15	1	Set 8th data bit to logic "1". This is a useful command for programmers who want to mix characters from both top and bottom of character set without calculating offsets. (For example, using reverse video with the default font.)
16		NO OPERATION.
17		NO OPERATION.
18		NO OPERATION.
19	1*	Set 8th data bit to logic "0". This disables the previous command (15h).
1A		RESERVED, do not use.
1B		See ESCAPE control codes.
1C	1	SET TO SCROLL MODE: Sets the display mode so that whenever the cursor reaches the last position in the last column or a line feed occurs while cursor is on last row, the screen will scroll up one row. The top row of data will be lost and the bottom row of the display will be spaces.
1D	1*	SET TO AUTO WRAP MODE: In this mode, the cursor will automatically wrap around to the next row. When the last character position on the screen is reached, the cursor will return to HOME position.
1E	1	BLANK DISPLAY: The display is blanked, but display memory is maintained and new data can be entered.
1F	1*	UNBLANK DISPLAY: The display is restored/turned to active state.

Note: *Indicates power up default.



COMMAND SET, GRAPHIC MODE (SOFTWARE INSTRUCTIONS)

CURSOR LOCATION - All cursor locations are based upon Pixel location - NOT - character column and row locations. The upper left hand corner is 000,000 (X, Y) while the lower right hand corner is 239, 063 (X, Y). The cursor auto-increments based upon the character font size by the width of the font. The cursor is not visible in graphic mode.

WRITE LOGIC - Within most commands, the WRITE LOGIC byte must be included:

- 0 = SET PIXELS (turn-on foreground pixels)
- 1 = XOR PIXELS (invert foreground pixels)
- 2 = RESET PIXELS (turn-off foreground pixels)
- 3 = OVERWRITE (turn-on foreground and turn-off background pixels, image load and graphic text commands only)

FONT SIZE

The FONT SIZE must be written before text is written. There are three standard fonts included in the graphics mode:

- 1 = FONT 1, a 4 x 5 character in a 5 x 6 block
- 2 = FONT 2, a 5 x 7 character in a 6 x 8 block
- 3 = FONT 3, a 10 x 14 character in a 12 x 16 block

Refer to character set tables for supported characters and fonts.

Note: The LOGIC byte and FONT byte are sent in ASCII format.

DATA FORMAT

All addresses must be sent in ASCII format. Column and row positions begin at the upper left hand corner at address 000,000 (X, Y).

A pixel address consists of a column address followed by row address. Addresses are sent to the panel as a three character ASCII sequence for column (x) followed by a three character ASCII sequence for row (y). An example is the upper left hand pixel is 000,000 while the lower right hand corner is 239, 063.

Note: Spaces are shown in the graphic sequences only for clarity and must not occur in the actual commands transmitted to the panel.

GRAPHIC FUNCTIONS	
HEX CODE	GRAPHIC FUNCTIONS
1B, 42	TEXT WRITE: Logic byte (l), font byte (f), x, y starting address, ASCII text. Wrap around will occur. ESC B l f xxx yyy aaaa..aaaa ESC \
1B, 43	CLEAR SCREEN: This command will clear the graphic screen to all pixels off (logic 0). ESC C
1B, 44	SET PIXEL COMMAND: Logic byte (l), x, y pixel address, end of data delimiter. ESC D l xxx yyy ESC \ (Single pixel) ESC D l xxx yyy xxx yyyESC \ (Continuous)
1B, 46	SET TEXT MODE: ESC F
1B, 47	SET GRAPHICS MODE: ESC G
1B, 48	DRAW ELLIPSE: Logic byte, major axis intercept offset, minor axis intercept offset (axis's intercept offset is measured in pixels from the center point), x, y center point, from angle theta (t), in degrees, to phi (p). A complete rotation would be from 001 to 360. ESC H l mmm www xxx yyy ttt ppp
1B, 49	WRITE GRAPHIC IMAGE: Logic byte 1, y1 (upper left hand corner), 2, y2 (width and height), data. ESC I l xxx yyy xxx yyy ddd X1 start coordinate and X2 width must both be multiples of 8. The number of data bytes transmitted must be equal to (X2 width / 8) * Y2 height. The first data byte transmitted will map into the 8 pixels on the top line in the upper left hand corner of the image with the least significant bit at the left and the most significant bit at the right. Successive bytes will write to the next byte to the right. When all bytes are written for this line, the next byte will map into the left most byte of the next line down. Graphical representation of each data byte: lsb x x x x x x msb



GRAPHIC SOFTWARE COMMANDS (Continued)	
HEX CODE	GRAPHIC FUNCTIONS
1B, 49 (Cont.)	<p>LOAD GRAPHIC IMAGE: (Continued)</p> <p>GRAPHICAL REPRESENTATION OF DATA ARRAY:</p> <pre> data 0 data 1 ... data (width/8) data (width/8 + 1) ... data (2 * width/8) data (2 * width/8 + 1) data (n * width/8) data (n * width/8 + 1) data (height-1) * width/8 ... data (height) * (width/8) - 1 </pre>
1B, 4A	<p>DRAW BOX: Logic byte, X1, Y1 (upper left hand corner). X2, Y2 (lower right hand corner).</p> <p>ESC J l xxx yyy xxx yyy</p>
1B, 4B	<p>DRAW LINE: Logic byte, X1, Y1 (beginning of line), X2, Y2 (end of line), data delimiter.</p> <p>(For single lines)</p> <p>ESC K l xxx yyy xxx yyy ESC \</p> <p>(For continuous lines)</p> <p>ESC K m xxx yyy xxx yyy xxx yyy ESC \</p>
1B, 4C	<p>FILL REGION: Logic byte, X1, Y1 (upper left corner), X2, Y2 (lower right hand corner).</p> <p>ESC L l xxx yyy xxx yyy</p>
1B, 4D	<p>READ GRAPHIC IMAGE: x1, y1 (upper left hand corner), x2, y2 (width and height)</p> <p>ESC M xxx yyy xxx yyy</p> <p>Graphic image information is returned by the display after receipt of this command. X1 start coordinate and X2 width must both be multiples of 8. Refer to WRITE GRAPHIC IMAGE command for format of data sent by display.</p>
1B, 4E	<p>SET DISPLAY PAGE: p</p> <p>ESC N p</p> <p>Sets the active display page of video RAM which is visible on the display. Two pages p are available, 0 - 1 (ASCII representation). Default is page 0, supported in graphics mode only.</p>
1B, 4F	<p>SET WRITE PAGE: p</p> <p>ESC O p</p> <p>Sets the active read/write page of video RAM on which all following commands operate. Two pages p are available, 0 - 1 (ASCII representation). Default is page 0, supported in graphics mode only.</p>
1B, 50	<p>COMBINE PAGES: Logic byte, p1 (source page 1), p2 (source page 2), p3 (destination page).</p> <p>ESC P l p p p</p> <p>Combines graphic information on source pages using logic write modes 0, 1 or 2 and places that information on the destination page. Use only with pages containing graphic information.</p>



CHARACTER FONTS

ASCII, Standard and Inverse Character Set, 0 - Text Mode

		UPPER NIBBLE D7 - D4																
		0	1	2	3	4	5	6	7	8	9	A	B	C	D	E	F	
LOWER NIBBLE D3 - D0	0	V	L		0	Q	P	`	P	Γ	I	■	□	□	□	□	□	□
	1	\$	4	!	1	A	Q	a	q	Γ	I	■	□	□	□	□	□	□
	2	5	5	"	2	B	R	b	r	Γ	I	■	□	□	□	□	□	□
	3	6	6	#	3	C	S	c	s	Γ	I	■	□	□	□	□	□	□
	4	7	7	\$	4	D	T	d	t	Γ	I	■	□	□	□	□	□	□
	5	8	8	%	5	E	U	e	u	Γ	I	■	□	□	□	□	□	□
	6	9	9	&	6	F	V	f	v	Γ	I	■	□	□	□	□	□	□
	7	0	0	'	7	G	W	g	w	Γ	I	■	□	□	□	□	□	□
	8	1	1	<	8	H	X	h	x	Γ	I	■	□	□	□	□	□	□
	9	2	2	>	9	I	Y	i	y	Γ	I	■	□	□	□	□	□	□
	A	3	3	*	:	J	Z	j	z	Γ	I	■	□	□	□	□	□	□
	B	4	4	+	:	K	[k	[Γ	I	■	□	□	□	□	□	□
	C	5	5	,	<	L	\	l	l	Γ	I	■	□	□	□	□	□	□
	D	6	6	-	=	M]	m]	Γ	I	■	□	□	□	□	□	□
	E	7	7	.	>	N	^	n	^	Γ	I	■	□	□	□	□	□	□
	F	8	8	/	?	O	_	o	_	Γ	I	■	□	□	□	□	□	□

International Character Set, 1 - Text Mode

		UPPER NIBBLE D7 - D4															
		0	1	2	3	4	5	6	7	8	9	A	B	C	D	E	F
LOWER NIBBLE D3 - D0	0	0	1		0	Q	P	`	P	E	Z		"	A	D	á	ó
	1	\$	4	!	1	A	Q	a	q	°	Q	i	±	A	N	á	ñ
	2	5	5	"	2	B	R	b	r	∞	∞	∞	∞	A	ó	á	ó
	3	6	6	#	3	C	S	c	s	∞	∞	∞	∞	A	ó	á	ó
	4	7	7	\$	4	D	T	d	t	L	+	Q	'	A	ó	á	ó
	5	8	8	%	5	E	U	e	u	∞	∞	∞	∞	A	ó	á	ó
	6	9	9	&	6	F	V	f	v	∞	∞	∞	∞	A	ó	á	ó
	7	0	0	'	7	G	W	g	w	ó	E	∞	∞	∞	∞	∞	∞
	8	1	1	<	8	H	X	h	x	e	∞	∞	∞	∞	∞	∞	∞
	9	2	2	>	9	I	Y	i	y	∞	∞	∞	∞	∞	∞	∞	∞
	A	3	3	*	:	J	Z	j	z	∞	∞	∞	∞	∞	∞	∞	∞
	B	4	4	+	:	K	[k	[∞	∞	∞	∞	∞	∞	∞	∞
	C	5	5	,	<	L	\	l	l	∞	∞	∞	∞	∞	∞	∞	∞
	D	6	6	-	=	M]	m]	∞	∞	∞	∞	∞	∞	∞	∞
	E	7	7	.	>	N	^	n	^	∞	∞	∞	∞	∞	∞	∞	∞
	F	8	8	/	?	O	_	o	_	∞	∞	∞	∞	∞	∞	∞	∞



CHARACTER FONTS

International and Katakana Character Set, 2 - Text Mode

		UPPER NIBBLE D7 - D4															
		0	1	2	3	4	5	6	7	8	9	A	B	C	D	E	F
LOWER NIBBLE D3 - D0	0	0	1	2	3	4	5	6	7	8	9	A	B	C	D	E	F
	1	!	"	#	\$	%	&	'	()	*	+	,	<	=	>	?
	2	0	1	2	3	4	5	6	7	8	9	A	B	C	D	E	F
	3	!	"	#	\$	%	&	'	()	*	+	,	<	=	>	?
	4	0	1	2	3	4	5	6	7	8	9	A	B	C	D	E	F
	5	!	"	#	\$	%	&	'	()	*	+	,	<	=	>	?
	6	0	1	2	3	4	5	6	7	8	9	A	B	C	D	E	F
	7	!	"	#	\$	%	&	'	()	*	+	,	<	=	>	?
	8	0	1	2	3	4	5	6	7	8	9	A	B	C	D	E	F
	9	!	"	#	\$	%	&	'	()	*	+	,	<	=	>	?
	A	0	1	2	3	4	5	6	7	8	9	A	B	C	D	E	F
	B	!	"	#	\$	%	&	'	()	*	+	,	<	=	>	?
	C	0	1	2	3	4	5	6	7	8	9	A	B	C	D	E	F
	D	!	"	#	\$	%	&	'	()	*	+	,	<	=	>	?
	E	0	1	2	3	4	5	6	7	8	9	A	B	C	D	E	F
	F	!	"	#	\$	%	&	'	()	*	+	,	<	=	>	?

International and Cyrillic Character Set, 3 - Text Mode

		UPPER NIBBLE D7 - D4															
		0	1	2	3	4	5	6	7	8	9	A	B	C	D	E	F
LOWER NIBBLE D3 - D0	0	0	1	2	3	4	5	6	7	8	9	A	B	C	D	E	F
	1	!	"	#	\$	%	&	'	()	*	+	,	<	=	>	?
	2	0	1	2	3	4	5	6	7	8	9	A	B	C	D	E	F
	3	!	"	#	\$	%	&	'	()	*	+	,	<	=	>	?
	4	0	1	2	3	4	5	6	7	8	9	A	B	C	D	E	F
	5	!	"	#	\$	%	&	'	()	*	+	,	<	=	>	?
	6	0	1	2	3	4	5	6	7	8	9	A	B	C	D	E	F
	7	!	"	#	\$	%	&	'	()	*	+	,	<	=	>	?
	8	0	1	2	3	4	5	6	7	8	9	A	B	C	D	E	F
	9	!	"	#	\$	%	&	'	()	*	+	,	<	=	>	?
	A	0	1	2	3	4	5	6	7	8	9	A	B	C	D	E	F
	B	!	"	#	\$	%	&	'	()	*	+	,	<	=	>	?
	C	0	1	2	3	4	5	6	7	8	9	A	B	C	D	E	F
	D	!	"	#	\$	%	&	'	()	*	+	,	<	=	>	?
	E	0	1	2	3	4	5	6	7	8	9	A	B	C	D	E	F
	F	!	"	#	\$	%	&	'	()	*	+	,	<	=	>	?



CHARACTER FONTS

Graphic Font 1

UPPER NIBBLE D7 - D4

	0	1	2	3	4	5	6	7	8	9	A	B	C	D	E	F
0				0	1	P										
1			!	1	A	Q										
2			"	2	B	R										
3			#	3	C	S										
4			\$	4	D	T										
5			%	5	E	U										
6			&	6	F	V										
7			'	7	G	W										
8			<	8	H	X										
9			>	9	I	Y										
A			*	:	J	Z										
B			+	;	K	[
C			,	<	L	\										
D			-	=	M]										
E			.	>	N	^										
F			/	?	O	_										

Graphic Font 2

UPPER NIBBLE D7 - D4

	0	1	2	3	4	5	6	7	8	9	A	B	C	D	E	F
0				0	@	P	'	F	E	Σ		"	À	0	á	ó
1			!	1	A	Q	a	q	°	Q	ı	±	Á	1	â	õ
2			"	2	B	R	b	r	ı	≡	φ	²	Â	2	ã	ö
3			#	3	C	S	c	s	ı	×	ε	³	Ã	3	ä	ç
4			\$	4	D	T	d	t	ı	÷	Q	´	Ä	4	å	ç
5			%	5	E	U	e	u	ø	÷	#	µ	Å	5	æ	ç
6			&	6	F	V	f	v	ı	?	ı	#	Æ	6	ß	ç
7			'	7	G	W	g	w	ó	E	ö	.	Ç	7	ç	ı
8			<	8	H	X	h	x	ı	≤	ı	,	È	8	è	ı
9			>	9	I	Y	i	y	ı	≥	ı	ı	É	9	é	ı
A			*	:	J	Z	j	z	ı	≠	ı	#	Ê	A	ê	ı
B			+	;	K	[k	[ı	Γ	ı	ı	Ë	B	ë	ı
C			,	<	L	\	ı	ı	ı	π	ı	ı	Ì	C	ì	ı
D			-	=	M]	m]	ı	ı	ı	ı	Í	D	í	ı
E			.	>	N	^	n	^	ı	ı	ı	ı	Î	E	î	ı
F			/	?	O	_	o	_	ı	ı	ı	ı	Ï	F	ï	ı



CHARACTER FONTS

Graphic Font 3

UPPER NIBBLE D7 - D4

	0	1	2	3	4	5	6	7	8	9	A	B	C	D	E	F
0			0	@	P	'	P	□								
1			!	1	A	Q	a	q	Ω							
2			"	2	B	R	b	r	0							
3			#	3	C	S	c	s	↑							
4			\$	4	D	T	d	t	↓							
5			%	5	E	U	e	u	←							
6			&	6	F	V	f	v	→							
7			'	7	G	W	g	w								
8			(8	H	X	h	x								
9)	9	I	Y	i	y								
A			*	:	J	Z	j	z								
B			+	;	K	[k	{								
C			,	<	L	\	l									
D			-	=	M]	m	}								
E			.	>	N	^	n	~								
F			/	?	O	_	o	△								

LOWER NIBBLE D3 - D0

ORDERING INFORMATION

DESCRIPTION

PART NUMBER

Display Unit.....	APD-240G064
J1, Power Connector Kit.....	280108-05
J2, Data Connector Kit (Parallel Interface, 26 Pin IDC).....	280105-01
J3, Data Connector Kit (Serial Interface, 10 Pin IDC)	280105-02
Non-Glare Filter (Amber CP).....	280109-12

Standard warranty is 1 year parts and labor.