

1-3 371/374

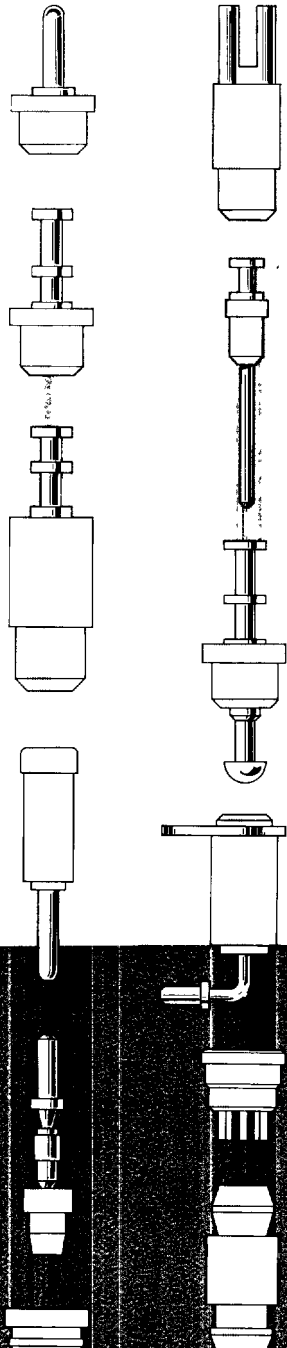

# sealectro

**BICC** **ELECTRONICS**



pl  
in  
ter

# Contents

- 1 Quick Reference Part Number Index
- 2 Technical Data
- 3 Press-Fit Installation Procedure, Step Drills
- 4 Press-Fit Stand-offs, subminiature
- 5 Press-Fit Stand-offs, subminiature and miniature
- 6 Press-Fit Feed-throughs, microminiature and subminiature
- 7 Press-Fit Feed-throughs, subminiature and miniature
- 8 Press-Fit Feed-throughs, Cloverleaf, Semi-Assembled
- 9 Press-Fit Test Point Jacks and Probes
- 10 2FT/2ST Series, Introduction and Specifications
- 11 2ST Series Stand-offs
- 12 2FT Series Feed-throughs, Flying Test Socket
- 13 2PR/2SK Two Piece Test Point Jacks and Probes, p.t.f.e. Bushings
- 14 P.C. Board Spacer Bushings
- 15 Press-Fit Transistor Sockets
- 16 Press-Fit Transistor Holders, Bushes and Pads

**Notes** The text and illustrative matter in this publication or any part thereof may not be reproduced in any manner whatsoever without written permission from Sealectro Limited.

The names "Press-Fit" and "Cloverleaf" are registered trade marks.

Whilst every effort has been made to ensure that this catalogue is accurate at the time of going to press, Sealectro Ltd. reserve the right to make design changes without notice as part of our continuous programme of product development.

**Sealectro Ltd. are a BS 9000, CAA and DEF. STAN 05-21 approved company. BS 9000 Approval Certificate No. 1069/M DEF. STAN 05-21 Registration No. 14MS01 CAA Reference No A1/6294/61**

Copyright 1986 Sealectro Ltd, Walton Road, Farlington, Portsmouth PO6 1TB  
Registered in England No 778058  
A member of the BICC Technologies Group

Printed in England by Potts & Horsey Limited

# Introduction

This catalogue covers the standard Sealectro ranges of Press-Fit One Piece Insulated Terminals Transistor Sockets Transistor Holders and Mounting Bushes 2FT/2ST Two Piece Insulated Terminals 2PR/2SK Insulated Probes and Sockets p.t.f.e. Bushings and Spacer Bushings

The original Press-Fit concept of a one-piece p.t.f.e. insulated terminal, or the alternative two-piece construction offer simplicity of installation overall economy and thorough reliability Sealectro Insulated Terminals do away with hardware such as threaded shanks nuts, washers and lockwashers Only a single insertion tool is required in locking the terminal into a chassis hole Once fitted the precisely machined metal lug is so constructed as to be firmly gripped in the p.t.f.e. providing a high resistance to torque and pull out after soldering of leads or when subjected to extremes of temperature

Sealectro Insulated Terminals enable you drastically to reduce the size of your equipment They are particularly suited to such important and critical applications as satellites guided missiles radar radio navigational equipments instrumentation of all kinds and a host of other commercial military and industrial applications

The items described in this catalogue are considered standard and are normally readily available Continual expansion of the range is always taking place and should we not illustrate your particular requirement please contact the Interconnection and Switching Division of Sealectro Limited whose engineers are at your service

## New Part Numbering System

To provide a faster service we are extending our internal computerised part numbering system to our customers for ordering the products contained in this catalogue We would like to reassure those customers who have standardised their drawings and purchasing records on Sealectro's alpha-numeric catalogue numbering system that we will continue that system in parallel with the new computerised system for some time to assist the changeover process Although we prefer orders in the new system we are happy to honour orders in either system

For simplicity only the first seven digits of the new thirteen digit part numbers are given here and a simple cross-reference may be found in the Index on Page 1 All items cross-referenced between the two systems are identical only the part numbers are changed

Standard plating and white p.t.f.e. bushes will always be supplied unless specified otherwise and the full 13 digit part number which includes plating and colour codes will appear on all Sealectro correspondence

## Example:

Old Catalogue Number	ST-SM-16 TUR
New Part Number (Abbreviated catalogue version)	003-2003
New Part Number (In full including standard plating code and white bushing colour code as appearing on Sealectro correspondence)	003-2003-040519

## WARNING

*Certain terminals shown in this catalogue are intended for use in areas of high voltage*

*Suitable safety precautions should be taken to ensure that personnel do not come into contact with live conductors during installation and operation*

# Part number, cross reference & index

Old Cat. Number.	New Part Number	Page	Old Cat. Number	New Part Number	Page	Old Cat. Number	New Part Number	Page	Old Cat. Number	New Part Number	Page
B-1414	119-0014	13	FT-MM-5SL	001-3012	6	RTC-303T	028-2007	16	ST-SM-2C4	013-1014	4
B-1416	119-0016	13	FT-MM-5TUR	001-2013	6	RTC-404T	028-2015	16	ST-SM-3	013-1019	4
B-1421	119-0021	13	FT-MM-16L2	001-1038	6	RTC-1010-SL	028-3005	16	ST-SM-16	003-1009	4
B-1432	119-0032	13	FT-SM-1	011-1004	6	SKT-0804	016-8010	9	ST-SM-16TUR	003-2003	4
B-1435	119-0034	13	FT-SM-1L4	011-1010	6	SKT-5BC	016-2000	9	ST-SM-21TUR	013-2009	4
B-1437	119-0036	13	FT-SM-1TUR	011-2004	6	SKT-14	016-2008	9	ST-SM-25TUR	013-2016	4
B-1439	119-0039	13	FT-SM-2C4	011-1015	6	SKT-31	016-6001	9	T-1470	119-0073	16
B-1440	119-0040	13	FT-SM-2TUR-C2	011-2014	6	SKT-102PC	026-4003	9	T-1496	119-0098	16
B-1441	119-0042	13	FT-SM-3L2	011-1019	6	SKT-103PC	026-4005	9	T-1499	119-0101	16
B-1447	119-0046	13	FT-SM-14	011-4021	6	SKT-400	016-6600	9	T-1500	119-0102	16
B-1447-1	119-0047	13	FT-SM-16	001-1007	6	2SK040	216-1002	13	T-1501	119-0103	16
B-1449	119-0050	13	FT-SM-16TUR	001-2004	6		116-1002		T-1517	119-0500	16
B-1450	119-0051	13	FT-SM-20TUR	011-2020	6	2SK050	216-1001	13	T-1523	119-0531	16
B-1466	119-0069	13	FT-SM-22TUR	011-2023	6		116-1001		T-1524	119-0503	16
B-1473	119-0076	13	FT-SM-34TUR	011-2027	6	2SK060	216-1000	13	T-1525	119-0504	16
2FS 040	216-6800	12	FT-SM-50L2	011-6002	7		116-1000		T-1526	119-0505	16
	116-6800		FT-SM-59	001-6033	7	2ST 093/01	203-1499	11	TS-302/1	027-6000	15
2FT 093/01	201-1499	12	FT-SM-60	011-6011	7		103-1499		TS-302/2	027-6004	15
	101-1499		FT-SM-62	011-6015	7	2ST 093/02	203-1498	11	TS-402/1	027-6007	15
2FT 093/02	201-1498	12	FT-SM-71	011-6022	7		103-1498		TS-402/2	027-6015	15
	101-1498		FT-SM-102/2	001-1407	8	2ST 093/03	203-1497	11	TS-502/2	027-6013	15
2FT 093/03	201-1497	12	FT-SM-103/2	011-1409	8		103-1497		TS-602/2	027-6011	15
	101-1497		FT-SM-103/3	011-1410	8	2ST 125/01	203-1496	11	TS-802/2	027-6009	15
2FT 125/01	201-1496	12	PR-10	011-4000	9		103-1496		TS-1002/23	027-6017	15
	101-1496		PR-302	021-4006	9	2ST 156/01	213-1499	11	TS-1202/25	027-6005	15
2FT 156/01	211-1499	12	PR-400	011-4600	9		113-1499		227258	119-0700	14
	111-1499		PR-800/1	021-4000	9	2ST 156/02	213-1498	11	227262	119-0701	14
2FT 156/02	211-1498	12	2PRO40	211-4004	13		113-1499		227266	119-0702	14
	111-1498			111-4001		2ST 156/03	213-1497	11	227270	119-0703	14
2FT 156/03	211-1497	12	2PRO50	211-4003	13		113-1499		227274	119-0704	14
	111-1498			111-4001		2ST 156/07	213-1493	11	227278	119-0705	14
2FT 156/04	211-1496	12	2PRO60	211-4002	13		113-1498		227282	119-0706	14
	111-1498			111-4001		ST-210	003-2007	5	227286	119-0707	14
FT-310	011-2049	7	RFT-SM-1TUR	012-2000	6	ST-250	013-2046	5	227290	119-0708	14
FT-1000	011-2062	7	RFT-SM-52B2	002-6002	7	ST-250SL	013-3005	5	227294	119-0709	14
FT-1000-DTUR	011-2064	7	RST-SM-1	014-1000	4	ST-1000	013-2058	5	227298	119-0710	14
FT-1000SL	011-3014	7	RST-SM-1B2	014-1001	4	ST-1000SL	013-3007	5	086-115-60		3
FT-1500	011-2072	7	RST-SM-1L8	014-1007	4	ST-1500	013-2069	5	136-160-60		3
FT-1500SL	011-3019	7	RST-SM-1TUR	014-2001	5	ST-2000	013-2082	5	136-160-82		3
FT-2500	021-2013	7	RST-SM-16	004-1007	4	ST-SM-1	013-1000	4	152-175-60		3
FT-E-12	011-6808	8	RST-SM-25TUR-C4	014-2009	5	ST-SM-1L2	013-1003	4	158-175-60		3
FT-E-15	011-6809	8	RST-SM-31TUR	014-2011	5	ST-SM-1L10	013-1009	4	172-195-60		3
FT-MM-L-10	229-1020	8	RTC-0808-SL	028-3001	16	ST-SM-1TUR	013-2001	4	205-235-60		3
FT-MM-L-12	229-1021	8	RTC-300-L2	028-6003	16	ST-SM-1TUR-C2	013-2003	4			

# Technical data

## Technical Data

Press-Fit Terminals have outstanding electrical, mechanical, thermal and chemical properties made possible through the use of uncontaminated p.t.f.e. resin — long known for its exceptional inherent physical properties — as well as close fabrication control. The highest production standards are assured because quality control at Sealectro is based on United Kingdom Ministry specifications and methods and these inspection procedures are carried on from receipt of the p.t.f.e. right down to the assembled terminals.

### Characteristics of p.t.f.e.

#### Electrical Properties

Volume Resistivity (50% RH, 23°C)	10 <sup>18</sup> ohm/cm
Dielectric Constant (60 Hz to 10 <sup>6</sup> Hz)	2.0-2.2
Dielectric Strength (volts/mil)	400-450
Dissipation (power) factor (60 Hz to 10 <sup>6</sup> Hz)	0.0002
Corona resistance (see ratings in tables)	No tracking or carbonizing
Capacitance (see ratings in tables)	Very low

#### Mechanical Properties

Tensile Strength	1500-2500 psi (105 kgf/cm <sup>2</sup> - 175 kgf/cm <sup>2</sup> )
Elongation	75-150%
Modulus of Elasticity	50,000-55,000 psi (3,500 kgf/cm <sup>2</sup> - 3,850 kgf/cm <sup>2</sup> )

#### Chemical Properties

Resistant to all acids and alkalis of all concentrations, as well as to all common solvents, fungus and rot.

Water absorption (24 hour immersion 1/8" (3.175) thickness)	0.01%
Burning Rate	None
Effect of Sunlight, Ultra-violet and Infra-red light	None
Temperature range (not affected by soldering operations or cryogenic environs)	-100°C to + 250°C (-148°F to + 482°F)

#### Testing Data

Capacitance and voltage measured with terminals installed in chassis permitting .040" (1.016) protrusion of the p.t.f.e. bushing but not more than .050" (1.27) thick

*Note: While the above values are typical of the materials used, they should not be quoted on users specifications or drawings of Sealectro Insulated Terminals.*

## Plating

Standard plating code for the lug portion of each terminal is stated at the bottom of each page.

P.20	Gold flash 0.000005" (0.13 μ) min. over silver 0.0003" (7.62 μ) min
P.51	Greville Tinned to Sealectro specification A0143502.
P.59	Bright acid tin 0.0003" (7.62 μ) min over 0.0002" (5.08 μ) min copper
P.99	Gold 0.000005" (0.13 μ)/0.00001" (0.25 μ) over nickel 0.0001" (2.54 μ)/0.00015" (3.81 μ)

## Bushing Colours

All terminals and bushes are manufactured with white p.t.f.e. as standard. Up to nine alternative colours may be specified on special order but these colours will be subject to minimum quantity requirements and a price surcharge. Please contact the Sales Department who will be pleased to quote for your requirements.

## Dimensions

All dimensions are in imperial measure with metric equivalents given in brackets or in orange throughout.

# Installation procedure

The Press-Fit method is the simplest, fastest, most economical terminal installation, with practically no restriction as to chassis material and thickness. The procedure is further simplified by the use of Insertion Tools available from Sealectro Limited. These inexpensive tools are designed to fit any drill press or hand-arbor press.

Recommended Insertion Tools for each terminal are listed in the first column following the terminal part number on each table in the catalogue.

(1) PUNCH OR DRILL HOLE in chassis  $.013'' \pm .002$  (0.05 mm) less than diameter of terminal section (dia "G" in tables) passing through chassis. Minimum protrusion of bushing passing through chassis  $.040''$  (1 mm). Maximum thickness of chassis  $.125''$  (3.18 mm), for greater thickness, ask for our recommendations. Countersink from breakout or die side of chassis (not from punch side).

(2) COUNTERSINK ENTRANCE EDGE . . . Use  $60^\circ$  countersink when chassis thickness is  $.040''$  (1mm) and over, use  $82^\circ$  countersink when chassis thickness is less than  $.040''$  (1 mm). This enables centring of terminal in hole and prevents scoring the p.t.f.e. bushing. Depth and maximum diameter of countersink is determined by thickness of chassis stock and bushing's major diameter.

(3) INSERTION TOOL . . . Insertion tool is placed in chuck of drillpress (power off) or hand arbor press. Terminal is held by tool, leaving assembler's hands free to index and centre chassis hole underneath tool. Proper pressure is applied and released just as soon as major diameter of terminal seats itself.

Bushing Minor Diameter (Diameter 'G' in tables)		Hole or punch Dia. A $\pm 0.002''$ ( $\pm 0.05$ )		Countersink Dia. B $+0.010'' -0.000''$ ( $+0.25-0.00$ )	
.075	1.90	.070	1.78	.083 $+0.005$ $-0.000$	2.11 $+13$ $-0.00$
.093	2.36	.086	2.18	.110	2.79
.104	2.64	.091	2.31	.115	2.92
.125	3.18	.113	2.87	.135	3.43
.148	3.76	.136	3.45	.160	4.06
.165	4.19	.152	3.86	.175	4.45
.171-.172	4.34-4.37	.158	4.01	.175	4.45
.185	4.70	.172	4.37	.195	4.95
.217-.218	5.51-5.54	.205	5.21	.235	5.97
.256	6.50	.243	6.17	.269	6.83
.290	7.37	.277	7.04	.305	7.75
.373	9.48	.360	9.15	.380	9.65
.513	13.03	.500	12.70	.537	13.64

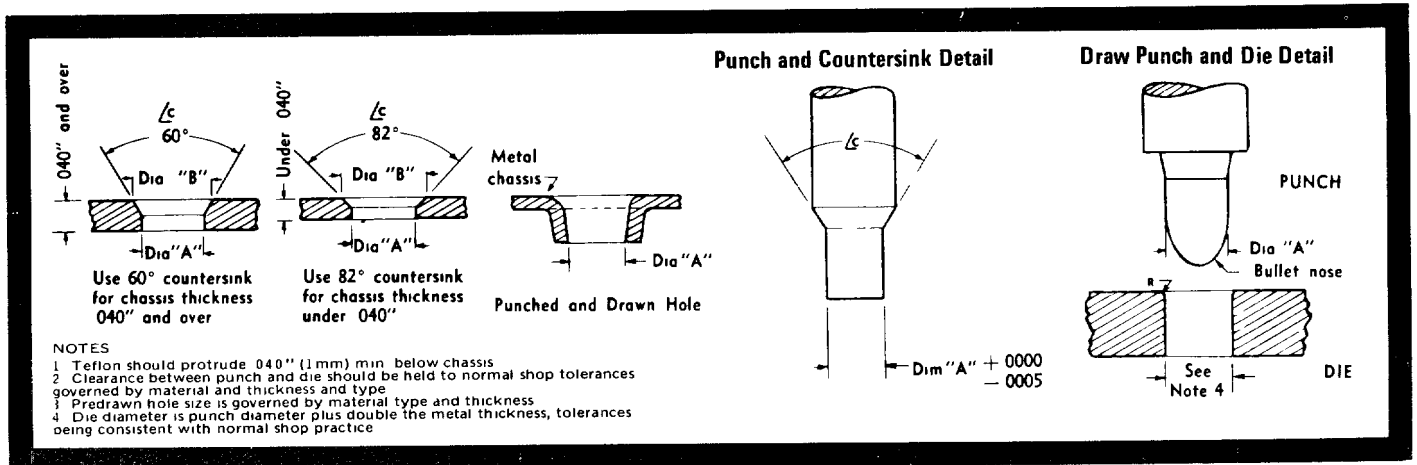

## Step drills

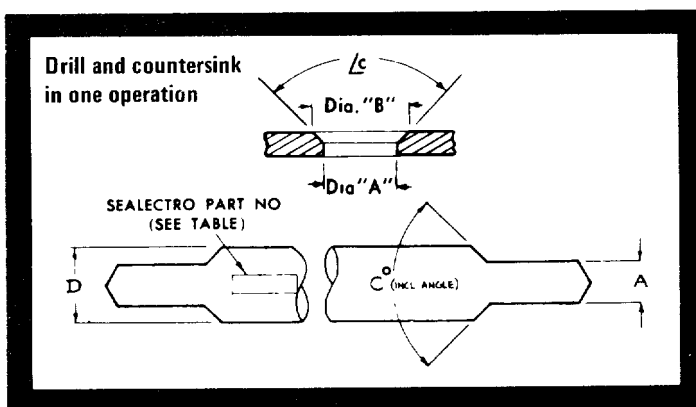

Sealectro Part No	A		B*		C <sup>o</sup>	D	
086-115-60	.086	2.18	.115	2.92	60	.187	4.75
136-160-60	.136	3.45	.160	4.06	60	.187	4.75
136-160-82	.136	3.45	.160	4.06	82	.187	4.75
152-175-60	.152	3.86	.175	4.45	60	.187	4.75
158-175-60	.158	4.01	.175	4.45	60	.187	4.75
172-195-60	.172	4.37	.195	4.95	60	.250	6.35
205-235-60	.205	5.21	.235	5.97	60	.250	6.35

Note: B\* is recommended diameter of countersink  $+0.010$  ( $+0.25$ )  $-0.000$  ( $-0.00$ )

# Stand-offs Subminiature

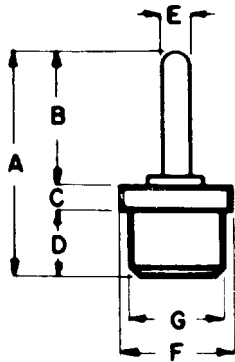

Fig 1

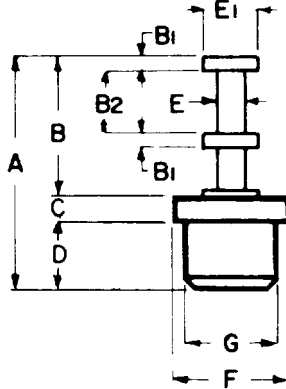

Fig 2

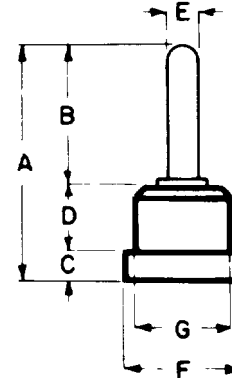

Fig 3

Fig.	Part No.	Tool No.	Approx. Capacitance m.m.f.	V.RMS 50 Hz		A	B	B <sub>1</sub>	B <sub>2</sub>	C	D	E Dia	E <sub>1</sub> Dia	F Dia	F <sub>2</sub> Dia	G Dia (+0.05 -0.00)
				Nominal Rating	Flashover Sea Level											
1	013-1000	B-8	0.45	1000	3000	.350	.210			.040	.100	.040		.172		.148
1	013-1003	B-8	0.40	1000	3000	8.9	5.3			1.0	2.5	1.0		4.4		3.76
1	013-1009	B-8	0.50	1000	3000	.265	.125			.040	.100	.040		.172		.148
1	013-1009	B-8	0.50	1000	3000	6.7	3.2			1.0	2.5	1.0		4.4		3.76
2	013-2001	B-8	0.40	1000	3000	.594	.450			.040	.100	.040		.172		.148
2	013-2001	B-8	0.40	1000	3000	15.1	11.5			1.0	2.5	1.0		4.4		3.76
2	013-2003	B-8	0.50	1000	3000	.350	.210	.020	.100	.040	.100	.040	.080		.172	.148
2	013-2003	B-8	0.50	1000	3000	8.9	5.3	0.5	2.5	1.0	2.5	1.0	2.0	4.4	3.76	
2	013-2003	B-8	0.50	1000	3000	.375	.210	.020	.100	.040	.125	.040	.080	.172	.148	
1	013-1014	B-8	0.40	1000	3000	9.5	5.3	0.5	2.5	1.0	3.2	1.0	2.0	4.4	3.76	
1	013-1014	B-8	0.40	1000	3000	.370	.210			.050	.110	.040		.172		.148
1	013-1019	B-15	0.45	1000	3000	9.4	5.3			1.3	2.8	1.0		4.4	3.76	
1	013-1019	B-15	0.45	1000	3000	.350	.210			.040	.100	.040		.195		.172
1	003-1009	B3-1	0.60	1000	3000	8.9	5.3			1.0	2.5	1.0		5.0	4.37	
1	003-1009	B3-1	0.60	1000	3000	.350	.210			.040	.100	.040		.125	.093	
2	003-2003	B3-2B	0.60	1000	3000	8.9	5.3			1.0	2.5	1.0		3.2	2.36	
2	003-2003	B3-2B	0.60	1000	3000	.350	.210	.020	.100	.040	.100	.040	.080		.125	.093
2	013-2009	B-18	0.40	1000	3000	8.9	5.3	0.5	2.5	1.0	2.5	1.0	2.0	3.2	2.36	
2	013-2009	B-18	0.40	1000	3000	.375	.210	.020	.100	.040	.125	.040	.080	.218	.185	
2	013-2016	B8-A	0.50	1000	3000	9.5	5.3	0.5	2.5	1.0	3.2	1.0	2.0	5.5	4.70	
2	013-2016	B8-A	0.50	1000	3000	.334	.154	.020	.046	.040	.140	.046	.093	.172	.148	
3	014-1000	B8-X1	0.40	1200	3500	8.5	3.9	0.5	1.2	1.0	3.6	1.2	2.4	4.4	3.76	
3	014-1000	B8-X1	0.40	1200	3500	.350	.210			.040	.100	.040		.172	.148	
3	014-1001	B8-G	0.40	1200	3500	8.9	5.3			1.0	2.5	1.0		4.4	3.76	
3	014-1001	B8-G	0.40	1200	3500	.330	.210			.020	.100	.040		.172	.148	
3	014-1007	B8-X1	0.50	1200	3500	8.4	5.3			0.5	2.5	1.0		4.4	3.76	
3	014-1007	B8-X1	0.50	1200	3500	.750	.610			.040	.100	.040		.172	.148	
3	004-1007	B3-2X	0.40	1000	3000	19.1	15.5			1.0	2.5	1.0		4.4	3.76	
3	004-1007	B3-2X	0.40	1000	3000	.350	.210			.040	.100	.040		.125	.093	
						8.9	5.3			1.0	2.5	1.0		3.2	2.36	

Standard plating P 51 (for plating specification see page 2)

# Stand-offs Subminiature & Miniature

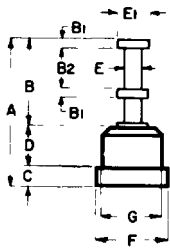

Fig. 4

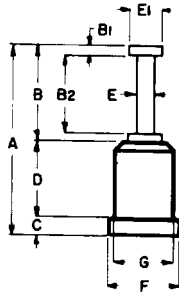

Fig. 5

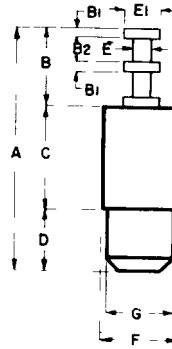

Fig. 6

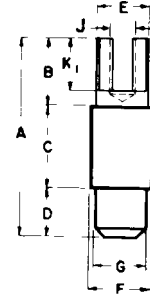

Fig. 7

Fig	Part No.	Tool No.	Approx. Capacitance m.m.f.	V.RMS 50 Hz		A	B	B <sub>1</sub>	B <sub>2</sub>	C	D	E Dia	E <sub>1</sub> Dia	F Dia	G Dia (+0.02 -0.00 +0.05 -0.00)	J Dia	K <sub>1</sub>
				Nominal Rating	Flashover Sea Level												
4	014-2001	B8-X-1	0.40	1200	3500	.350 8.9	.210 5.3	.020 0.5	.100 2.5	.040 1.0	.100 2.5	.040 1.0	.080 2.0	.172 4.4	.148 3.76		
4	014-2009	B8-X-1	0.40	1500	4000	.295 7.5	.156 4.0	.020 0.5	.046 1.2	.040 1.0	.100 2.5	.046 1.2	.093 2.4	.172 4.4	.148 3.76		
5	014-2011	B8-X-1	0.50	1700	4500	.455 11.5	.227 5.8	.020 0.5	.187 4.8	.040 1.0	.187 4.8	.040 1.0	.080 2.0	.172 4.4	.148 3.76		
6	003-2007	B3-A	0.50	1500	4000	.346 8.8	.156 4.0	.020 0.5	.046 1.2	.103 2.6	.087 2.2	.046 1.2	.093 2.4	.125 3.2	.104 2.64		
6	013-2046	B12	0.30	2500	6000	.431 10.9	.156 4.0	.020 0.5	.046 1.2	.125 3.2	.150 3.8	.046 1.2	.093 2.4	.187 4.8	.165 4.19		
7	013-3005	B11	0.70	2000	5000	.478 12.1	.203 5.2			.125 3.2	.150 3.8	.148 3.8		.187 4.8	.171 4.34	.078 2.0	.156 4.0
6	013-2058	B13	0.20	2800	6700	.493 12.5	.156 4.0	.020 0.5	.046 1.2	.187 4.7	.150 3.8	.046 1.2	.093 2.4	.187 4.8	.165 4.19		
7	013-3007	B11	0.70	2300	5600	.540 13.7	.203 5.2			.187 4.8	.150 3.8	.148 3.8		.187 4.8	.171 4.34	.078 2.0	.156 4.0
6	013-2069	B12-3	0.20	3100	7300	.556 14.1	.156 4.0	.020 0.5	.046 1.2	.250 6.4	.150 3.8	.046 1.2	.093 2.4	.187 4.8	.165 4.19		
6	013-2082	B13-3B	0.25	4500	10,000	.831 21.1	.281 7.1	.031 0.8	.093 2.4	.400 10.2	.150 3.8	.046 1.2	.125 3.2	.187 4.8	.165 4.19		
Standard plating P 51 (for plating specification see page 2)																	

# Feed-throughs Microminiature & Subminiature

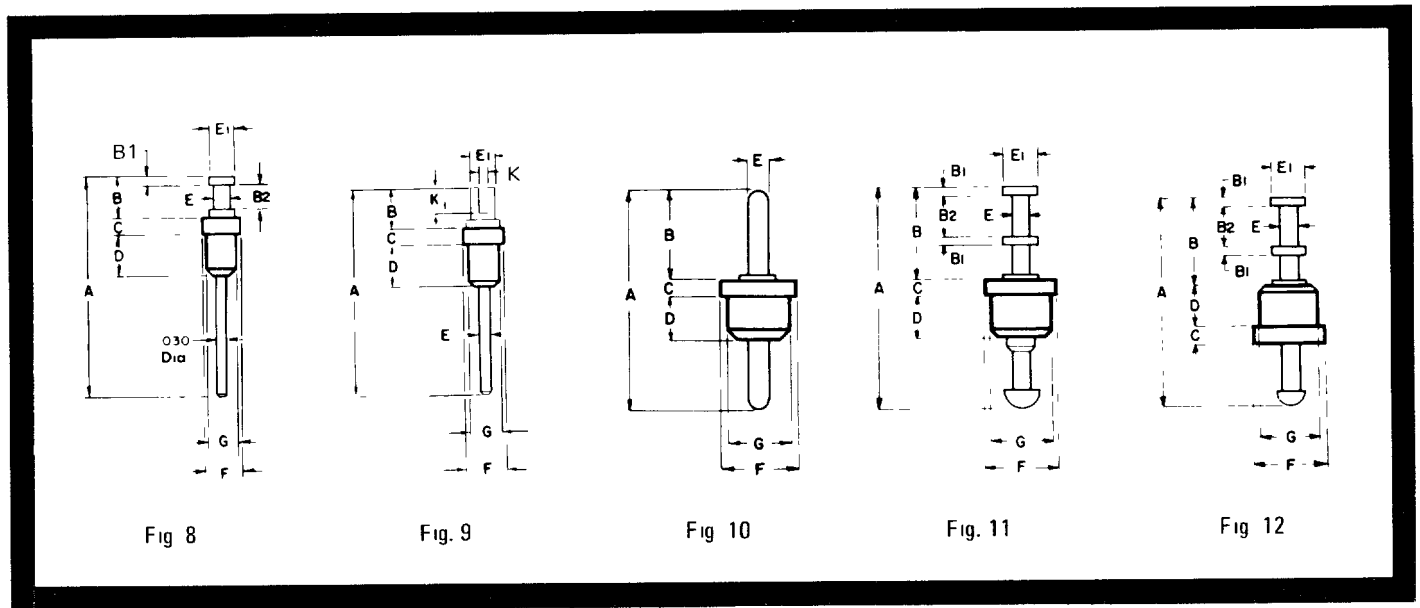

Fig.	Part No.	Tool No.	Approx. Capacitance m.m.f.	V.RMS 50 Hz		A	B	B1	B2	C	D	E Dia	E1 Dia	F Dia	G Dia (+0.05 -0.00)	K	K1
				Nominal Rating	Fleshover Sea Level												
8	001-2013	B0	0.70	400	1800	.510	.100	.020	.060	.040	.100	.040	.060	.093	.075		
9	001-3012	B0-1	0.70	400	1800	13.0	2.5	0.5	1.5	1.0	2.5	1.0	1.5	2.4	1.91	.024	.080
						.510	.100			.040	.100	.030	.060	.093	.075		
10	001-1038	B0-2	0.70	400	1800	13.0	2.5			1.0	2.5	0.8	1.5	2.4	1.91	0.6	2.0
						.550	.275			.040	.100	.030		.093	.075		
10	011-1004	B8-16	0.50	1000	3000	14.0	7.0			1.0	2.5	0.8	2.4	1.91			
10	011-1010	B8-16	0.70	1000	3000	.515	.210			.040	.100	.040		.172	.148		
						13.1	5.3			1.0	2.5	1.0	4.4	3.76			
11	011-2004	B8	0.50	1000	3000	1.000	.210	.020	.100	.040	.100	.040	.080	.172	.148		
						25.4	5.3			1.0	2.5	1.0	4.4	3.76			
10	011-1015	B8-18	0.50	1200	3500	.500	.210	.020	.100	.040	.100	.040	.080	.172	.148		
						12.7	5.3	0.5	2.5	1.0	2.5	1.0	2.0	4.4	3.76		
11	011-2014	B8	0.70	1000	3000	.535	.210			.050	.110	.040		.172	.148		
						13.6	5.3			1.3	2.8	1.0	4.4	3.76			
10	011-1019	B15	0.55	1200	3500	.531	.210	.020	.100	.040	.125	.040	.080	.172	.148		
						13.5	5.3	0.5	2.5	1.0	3.2	1.0	2.0	4.4	3.76		
10	011-4021	B8-16	0.50	1000	3000	14.2	5.3			1.0	2.5	1.0	5.0	4.37			
						.375	.125			.040	.100	.040	.172	.148			
10	001-1007	B3-1	0.75	500	2000	9.5	3.2			1.0	2.5	1.0	4.4	3.76			
						.515	.210			.040	.100	.040	.125	.093			
11	001-2004	B-3-2B	0.70	500	2000	13.1	5.3	.020	.100	.040	.100	.040	.080	.125	.093		
						.500	.210			1.0	2.5	1.0	3.2	2.36			
11	011-2020	B18	0.65	1200	3500	12.7	5.3	0.5	2.5	1.0	2.5	1.0	2.0	3.2	2.36		
						.531	.210	.020	.100	.040	.100	.040	.080	.218	.185		
11	011-2023	B9	0.65	1200	3500	13.5	5.3	0.5	2.5	1.0	2.5	1.0	2.0	5.5	4.70		
						.609	.210	.020	.100	.093	.125	.040	.080	.172	.148		
11	011-2027	B19-A	0.55	1500	4000	15.5	5.3	0.5	2.5	2.4	3.2	1.0	2.0	4.4	3.76		
						.609	.210	.020	.100	.093	.125	.040	.080	.218	.185		
12	012-2000	B8	0.50	1000	3000	15.5	5.3	0.5	2.5	2.4	3.2	1.0	2.0	5.5	4.70		
						.500	.210	.020	.100	.040	.100	.040	.080	.172	.148		
						12.7	5.3	0.5	2.5	1.0	2.5	1.0	2.0	4.4	3.76		

Standard Plating P 51 (for plating specification see page 2)

# Feed-throughs Subminiature & Miniature

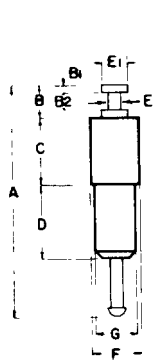

Fig 13

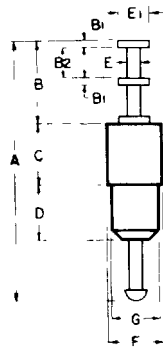

Fig 14

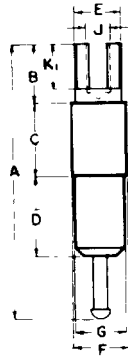

Fig. 15

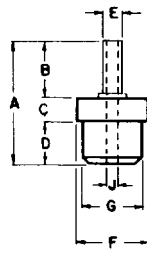

Fig. 16

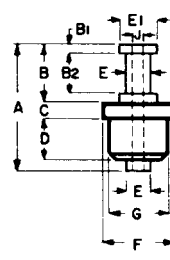

Fig 17

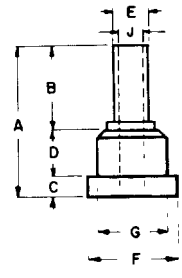

Fig 18

Fig.	Part No	Tool No.	Approx Capacitance m.m.f.	V.RMS 50 Hz		A	B	B <sub>1</sub>	B <sub>2</sub>	C	D	E Dia	E <sub>1</sub> Dia	F Dia	G Dia (+0.05 -0.00)	J	K <sub>1</sub>
				Nominal Rating	Flashover Sea Level												
13	011-2049	B10	0.75	1700	4500	.540 13.7	.133 3.4	.020 0.5	.093 2.4	.063 1.6	.171 4.3	.046 1.2	.093 2.4	.187 4.8	.171 4.34		
13	011-2062	B13	0.70	2200	5500	.740 18.8	.125 3.2	.031 0.8	.062 1.6	.187 4.8	.212 5.4	.050 1.3	.093 2.4	.187 4.8	.171 4.34		
15	011-3014	B11	0.80	2000	5000	.821 20.9	.203 5.2			.187 4.8	.212 5.4	.148 3.8		.187 4.8	.171 4.34	.078 2.0	.156 4.0
14	011-2064	B13-3B	0.80	2000	5000	.836 21.2	.250 6.4	.020 0.5	.093 2.4	.187 4.8	.212 5.4	.050 1.3	.093 2.4	.187 4.8	.171 4.34		
13	011-2072	B12-3	0.70	3000	7000	.865 22.0	.125 3.2	.031 0.8	.062 1.6	.250 6.4	.275 7.0	.050 1.3	.093 2.4	.187 4.8	.171 4.34		
15	011-3019	B13-X-3	0.90	2500	6000	.947 24.1	.203 5.2			.250 6.4	.275 7.0	.148 3.8		.187 4.8	.171 4.34	.078 2.0	.156 4.0
13	021-2013	B26	1.70	4500	10,000	1.365 34.7	.125 3.2	.031 0.8	.062 1.6	.500 12.7	.525 13.3	.050 1.3	.125 3.2	.250 6.4	.217 5.51		
16	011-6002	B8-13-A	0.30	750	2500	.250 6.4	.147 3.7			.050 1.3	.053 1.3	.040 1.0		.172 4.4	.148 3.76	.030 0.8	
16	001-6033	B3-1	0.40	500	2000	.225 5.7	.125 3.2			.040 1.0	.060 1.5	.040 1.0		.125 3.2	.093 2.36	.030 0.8	
16	011-6011	B18-1	0.70	1000	3000	.367 9.3	.207 5.3			.050 1.3	.110 2.8	.085 2.2		.218 5.5	.171 4.34	.063 1.6	
16	011-6015	B8-13-A	0.75	750	2500	.367 9.3	.207 5.3			.050 1.3	.110 2.8	.085 2.2		.172 4.4	.148 3.76	.063 1.6	
17	011-6022	B8-A	0.50	1000	3000	.303 7.7	.133 3.4	.020 0.5	.093 2.4	.040 1.0	.100 2.5	.060 1.5	.090 2.3	.172 4.4	.148 3.76	.030 0.8	
18	002-6002	B6-C	0.30	750	2500	.225 5.7	.125 3.2			.025 0.6	.075 1.9	.040 1.0		.150 3.8	.125 3.18	.030 0.8	

Standard plating P 51

(for plating specification see page 2)

# Feed-throughs

## CLOVERLEAF

The Press-Fit Cloverleaf Receptacle provides economical, yet uniformly perfect solder joints by means of dip-soldering with metal chassis. The unique Cloverleaf configuration permits insertion of four or more wire leads, plus an optional centre pin post for mounting additional components after the dip-soldering operation.

The reliability of dip solder joints made with the Cloverleaf receptacle, combined with the inherent dependability and repairability of metal chassis construction makes it ideal for use in high density, complex electronic instrumentation

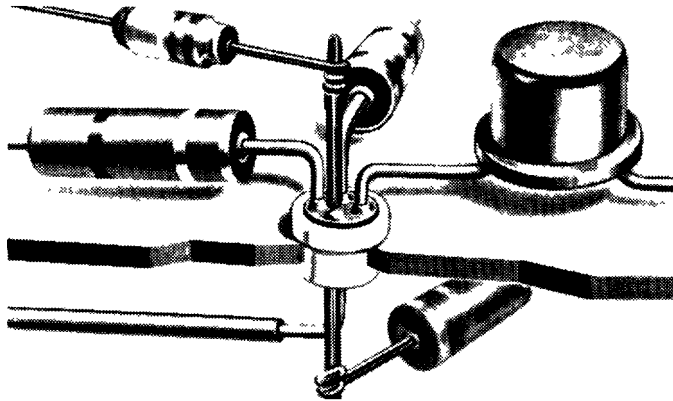

packaging, while the low cost of the terminal and its installation provides a new and better assembly technique for premium quality radio and television manufacturing.

Specification	011-6808	011-6809
Insertion Tool No	B-9-4	B-9-5
Chassis Thickness	0.040" - 0.060" (1.02 - 1.54)	0.040" - 0.060" (1.02 - 1.54)
Chassis Hole Diameter	0.136" ± 0.002" (3.45 ± 0.05)	0.172" ± 0.002" (4.4 ± 0.05)
Chassis Hole Countersink Diameter (60°)	0.160" + 0.010" - 0.000" (4.06 + 0.03 - 0.00)	0.195" + 0.010" - 0.000" (5.00 + 0.03 - 0.00)
Insert Material & Finish	Bronze P 59	
Suitable for Wire Lead	23 SWG or smaller (0.6)	20 SWG or smaller (0.9)
Approx. Capacitance	0.75 mmf	0.90 mmf
Voltage Rating Nominal (RMS)	500 V	500 V
Voltage Rating Flashover (RMS)	2000 V	2000 V
Centre Pin Material and Finish	Brass - Bright Acid Tin Plated	

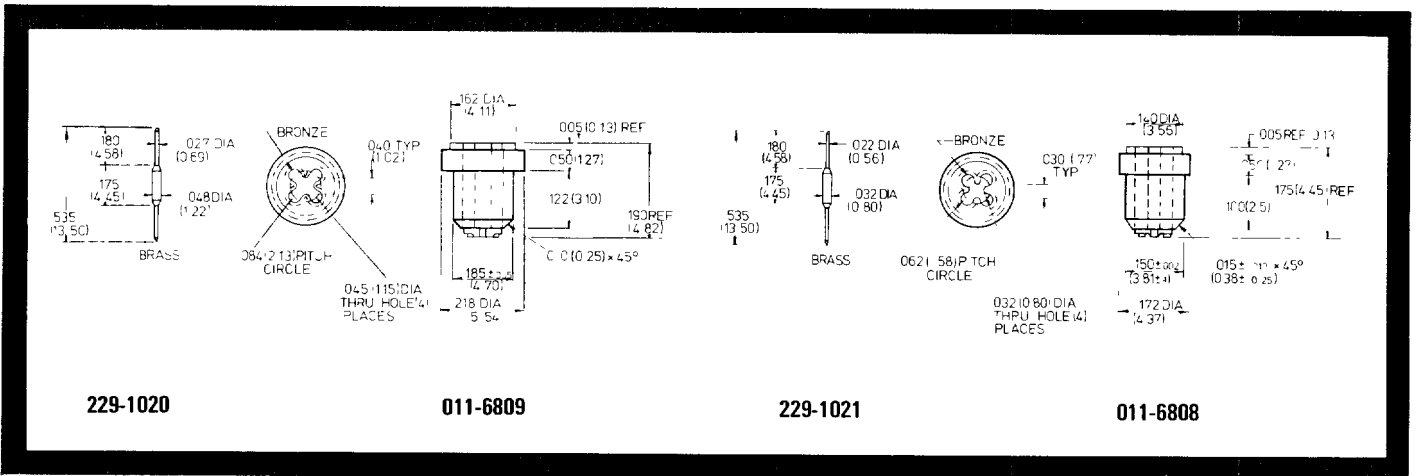

## Semi-assembled

This style of terminal is positioned in the unchamfered chassis hole with the terminal pin partly inserted in the insulator. The

pin is then pressed fully home expanding the insulator and locking the terminal in position.

Fig.	Part No.	Tool No	Approx. Capacitance (mmf)	Peak Voltage Rating	Nominal Current Rating (Angul)	Chassis Hole Size	Recommended Chassis Thickness	Standard Plating	A	B	B <sub>1</sub>	B <sub>2</sub>	C	D	E	E <sub>1</sub>	F	G
19	001-1407	R9	0.75	1000	1	0.091 - 0.095 2.32 - 2.42	0.030-0.056 0.76-1.42	P 60	460 11.69	.120 3.05	0.20 5.1	0.311 7.90	0.055 1.40	0.092 2.34	0.040 1.00	0.093 2.36	0.124 3.15	0.090 2.29
19	011-1409	R8	1.00	2000	5	0.154 - 0.158 3.91 - 4.02	0.056-0.115 0.76-2.92	P 60	691 17.55	0.125 3.18	0.030 0.76	0.443 11.25	0.093 2.36	0.155 3.94	0.075 1.91	0.125 3.18	0.188 4.78	0.153 3.89
19	011-1410	R7	1.00	2000	5	0.154 - 0.158 3.91 - 4.02	0.056-0.115 0.76-2.92	P 51	828 21.04	0.250 6.35	0.040 1.02	0.580 14.73	0.093 2.36	0.155 3.94	0.075 1.91	0.125 3.18	0.188 4.78	0.153 3.89

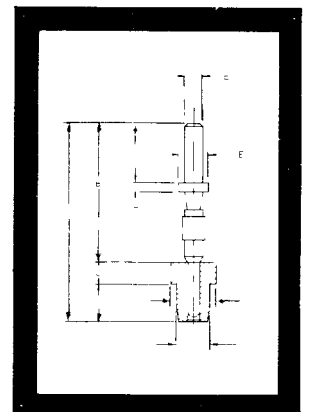

PRESS-FIT ONE PIECE SERIES  
**Test Point Jacks & Probes**

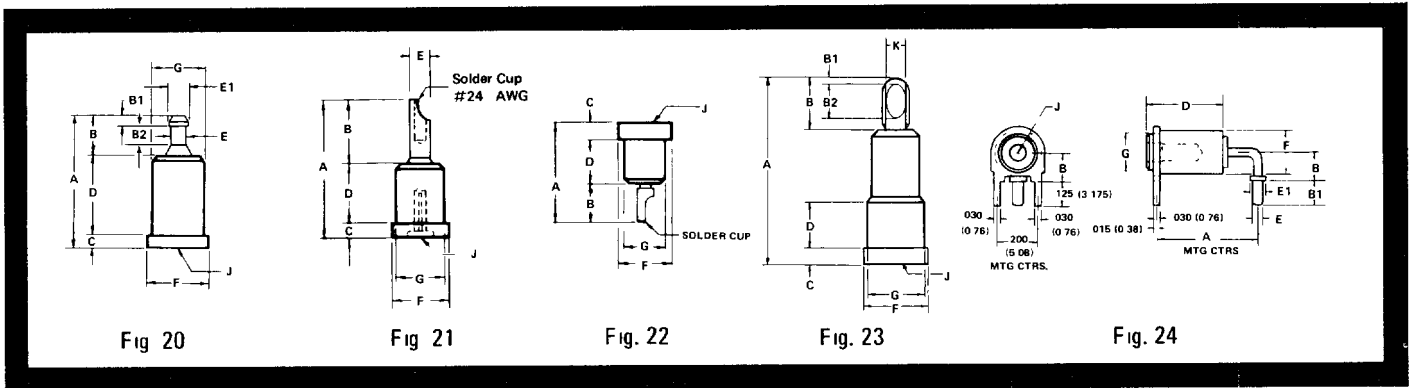

Fig.	Part No.	Tool No.	Approx. Capacitance m.m.f.	V. RMS 50 Hz		A	B	B <sub>1</sub>	B <sub>2</sub>	C	D	E Dia	E <sub>1</sub> Dia.	F Dia.	G Dia. (+0.002 -0.000)	J Probe Dia.	J <sub>1</sub> Probe Lgth.	K
				Nominal Rating	Flashover Sea Level													
20	016-2000	S2	0.60	1000	3000	.437	.120	.037	.053	.046	.271	.054	.074	.218	.185	.080	.195	
						11.1	3.0	0.9	1.3	1.2	6.9	1.4	1.9	5.5	4.70	2.03	5.0	
20	016-2008	S5	0.35	1000	3000	.345	.120	.023	.077	.046	.179	.040	.060	.172	.148	.040	.140	
						8.8	3.0	0.6	2.0	1.2	4.5	1.0	1.5	4.4	3.76	1.02	3.6	
21	016-6001	S17	0.45	1000	3000	.408	.187			.046	.175	.060		.172	.148	.040	.135	
						10.4	4.7			1.2	4.4	1.5		4.4	3.76	1.02	3.4	
24	026-4003		0.45	1200	3500	.500	.140	.125			.378	.050	.080	.218	.187	.080	.250	
						12.7	3.6	3.2			9.6	1.3	2.0	5.5	4.8	2.03	6.4	
24	026-4005		0.50	1200	3500	.400	.140	.125			.378	.050	.080	.218	.187	.080	.250	
						10.2	3.6	3.2			9.6	1.3	2.0	5.5	4.8	2.03	6.4	
22	††016-6600	S17	0.50	1000	3000	.359	.140			.065	.154			.187	.148	.040	.125	
						9.1	3.6			1.7	3.9			4.7	3.76	1.02	3.2	
23	016-8010	S38	0.75	1000	3000	.637	.171	.028	.116	.050	.175			.218	.185	.080	.312	.055
						16.2	4.3	0.7	2.9	1.3	4.4			5.5	4.70	2.03	7.9	1.4

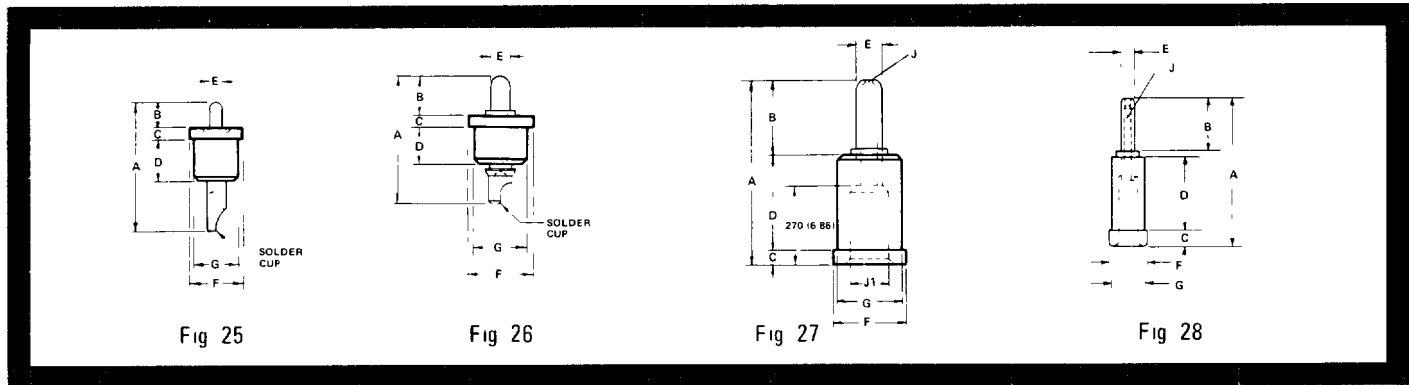

Fig	Part No.	Tool No	Approx Capacitance m.m.f	V. RMS 50 Hz		A	B	C	D	E Dia	F Dia	G Dia (+0.002 -0.000)	J Dia	J <sub>1</sub> Dia
				Nominal Rating	Flashover Sea Level									
25	011-4000	B8-14	0.70	1000	3000	.538	.130	.046	.175	.040	.172	.148		
						13.7	3.3	1.2	4.4	1.02	4.4	3.76		
27	021-4006	B-22X1	0.20	3400	7800	.645	.270	.050	.325	.080	.250	.218	.062	.128
						16.4	6.9	1.3	8.3	2.03	6.4	5.54	1.6	3.3
26	††011-4600	B-13-3	0.55	1000	3000	.407	.125	.065	.090	.040	.187	.148		
						10.3	3.2	1.7	2.3	1.02	4.7	3.76		
28	*021-4000					.785	.300	.094	.360	.080	.218	.187	.062	
						19.9	7.6	2.4	9.14	2.03	5.54	4.8	1.6	

# 2FT/2ST Two piece series

- ★ **STAND-OFF AND FEED-THROUGH STYLES**
- ★ **TWO-PIECE CONSTRUCTION**
- ★ **HIGH GRADE PTFE INSULATION**
- ★ **NO COUNTERSINK NEEDED FOR PUNCHED OR DRILLED HOLES**
- ★ **HIGH RESISTANCE TO PULL OUT**

## Introduction

The newest addition to the Sealectro range of p.t.f.e. insulated terminals, the series 2FT/2ST two piece terminals are designed for insertion into unchamfered chassis holes. The insulating bush is first pushed into the pre-drilled or punched hole and the lug, when inserted into the bush, locks the assembly rigidly into the chassis providing a high resistance to pull-out forces.

Bushes are supplied in three diameters to suit chassis hole diameters of 0.093", 0.125" and 0.156" respectively.

Lugs of various lengths and configurations are available to suit the application.

Part numbers for Insertion Tools are shown for each terminal. These tools are inexpensive units designed to fit any drill-press or hand-armor press for fast installation of terminals. Recommended for quantity production.

Design controlled dimensions are those shown in imperial sizes.

This range has been designed to meet or exceed the requirements of DEF STAN 5940 Part 2, Issue 2

## General Specification

<b>CHASSIS HOLE DIAMETER</b>	0.093" ± 0.002" 23-71	0.125" ± 0.002" 31-37	0.156" ± 0.002" 39-46
<b>CHASSIS THICKNESS</b>	13-22 SWG 0.092" - 0.028" 23-71	16-18 SWG 0.064" - 0.048" 16-23	10-22 SWG 0.128" - 0.028" 23-71
<b>RESISTANCE TO TEST PULL (Axial)</b>	22 Newtons 5 lb F	35 Newtons 8 lb F	66 Newtons 15 lb F
<b>CAPACITANCE</b>	< 1 pF	< 0.8 pF	< 0.75 pF
<b>VOLTAGE PROOF (Sea Level)</b>	> 4 KVDC	> 5 KVDC	> 5 KVDC
<b>INSULATOR RESISTANCE</b>		> 15 G ohms	
<b>CURRENT RATING (for 10<sup>0</sup> rise ΔT)</b>	6 A	8.5 A	9 A
<b>TEMPERATURE RATING</b>	-55°C to +200°C		
<b>MATERIALS:</b>	LUG: Brass BUSH: White ptfe		
<b>LUG PLATING</b>	P 51 (for plating specification see page 2)		

# Stand-offs

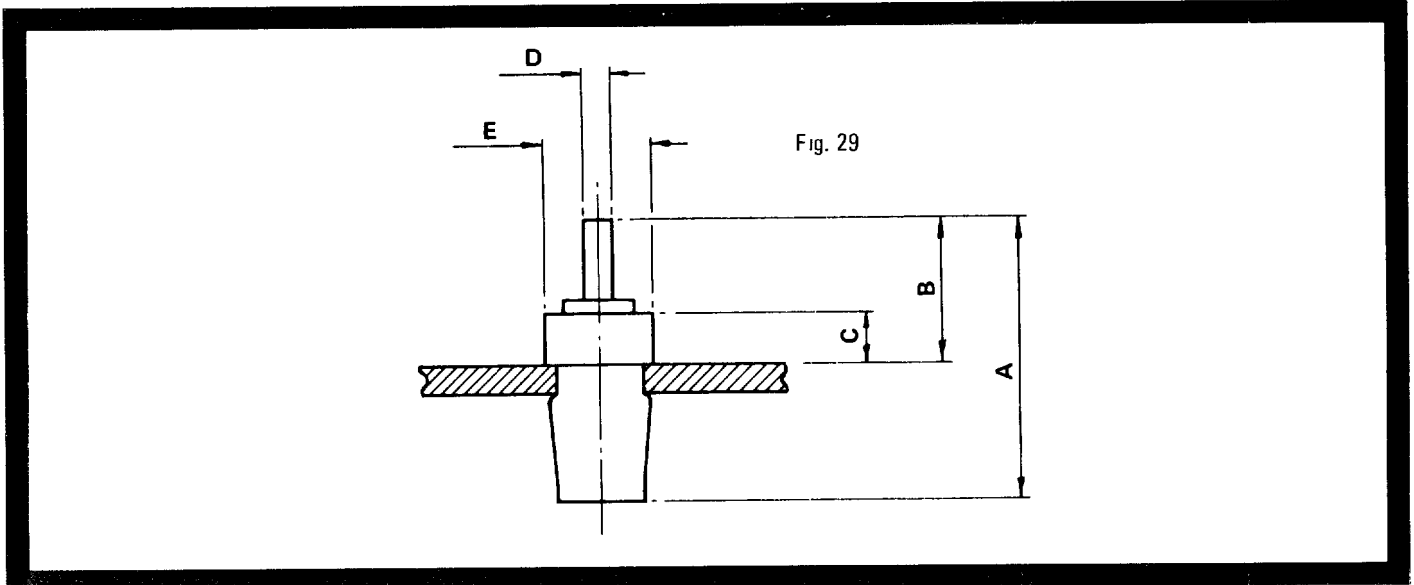

Fig.	Part No	Tool No.	A	B	C	D	E	Chassis Thickness SWG	Hole Size
29	203-1499 103-1499 (TP/14/B1)	R6	.463	.288	.055	.050	.125	13/14	.093
			11 76	7 32	1.40	1.27	3 18		2 36
29	203-1498 103-1498 (TP/14/B)	R6	.337	.218	.055	.050	.125	20/22	.093
			8 56	5 54	1 40	1.27	3 18		2 36
29	203-1497 103-1497	R6	.409	.264	.055	.050	.125	16/18	.093
			10 39	6 71	1 40	1 27	3 18		2 36
29	203-1496 103-1496	R4	.528	.378	.093	.054	.156	16/18	.125
			13 41	9 60	2 36	1 37	3 97		3 18
29	213-1499 113-1499 (TP/14/A2)	R10	.747	.325	.095	.054	.187	16/18	.156
			18 98	14 41	2 42	1 37	4 75		3 96
29	213-1498 113-1499 (TP/14/A)	R3	.432	.252	.095	.054	.187	16/18	.156
			10 98	6 40	2 42	1 37	4 75		3 96
29	213-1497 113-1499 (TP/14/A1)	R3	.557	.377	.095	.054	.187	20/22	.156
			14 15	9 58	2 42	1 37	4 75		3 96
29	213-1493 113-1498	R3	.640	.395	.095	.054	.187	10/13	.156
			16 26	10 04	2 42	1 37	4 75		3 96

Equivalent DEF STAN. 5940 part numbers are given in brackets  
Standard plating P.51 (for plating specifications see page 2)

# Feed-throughs

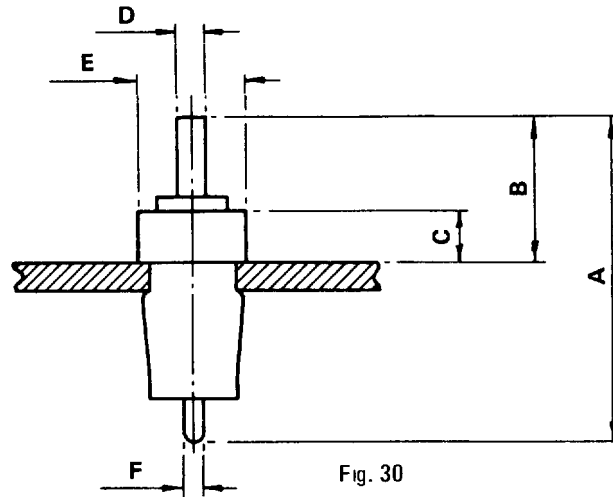

Fig. 30

Fig	Part No	Tool No	A	B	C	D	E	F	Chassis Thickness SWG	Hole Size
30	201-1499 101-1499 (TL/8/B1)	R6	614 15 60	274 6 96	055 1 40	050 1 27	125 3 18	032 0 82	13/14	093 2 36
30	201-1498 101-1498 (TL/8/B2)	R6	500 12 70	220 5 59	055 1 40	050 1 27	125 3 18	032 0 82	16/18	093 2 36
30	201-1497 101-1497 (TL/8/B)	R6	420 10 67	197 5 00	055 1 40	050 1 27	125 3 18	032 0 82	20/22	093 2 36
30	201-1496 101-1496	R4	687 17 45	316 8 03	093 2 36	054 1 37	156 3 96	032 0 82	16/18	125 3 18
30	211-1499 111-1499 (TL/8/A3)	R3	690 17 53	277 7 04	095 2 42	054 1 37	187 4 75	050 1 27	10/13	156 3 96
30	211-1498 111-1498 (TL/8/A)	R3	563 14 30	246 6 25	095 2 42	054 1 37	187 4 75	050 1 27	16/18	156 3 96
30	211-1497 111-1498 (TL/8/A2)	R3	540 13 72	235 5 97	095 2 42	054 1 37	187 4 75	050 1 27	20/22	156 3 96
30	211-1496 111-1498 (TL/8/A1)	R3	687 17 45	312 7 93	095 2 42	054 1 37	187 4 75	050 1 27	16/18	156 3 96

Equivalent DEF STAN 5940 part numbers are given in brackets

Standard plating P 51 (for plating specification see page 2)

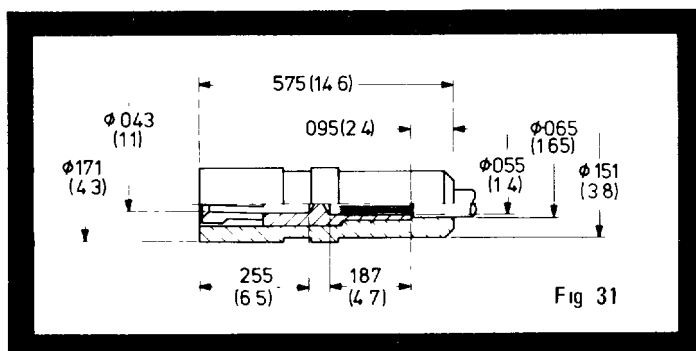

Fig 31

## Flying Test Socket

### General Specification

Part Number	216-6800/116-6800
For probe diameter	0 040" (1 02)
For probe length	0 250" (6 35)
For wire jacket diameter	0 065" (1 65) max
For wire conductor diameter	0 050" (1 27) max
Operating current	2 Amps
Contact resistance	< 2m ohms
Materials - Socket lug	Beryllium copper with gold plated (P 20) finish
Insulator	White p t f e with finger grip

Note: Insulator & socket are supplied separately

# Test Point Jacks & Probes

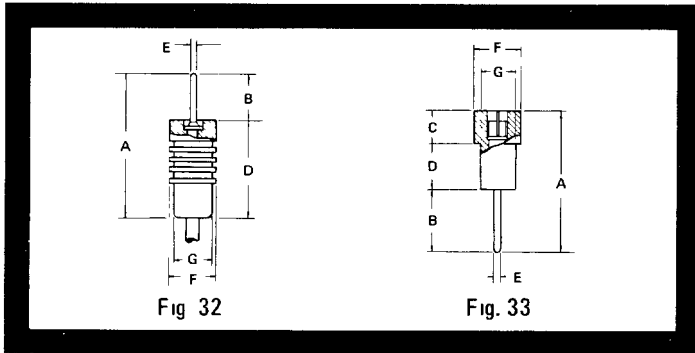

## General Specification

Chassis Hole Diameter	0.156 in (4.00)
Chassis Thickness	16-10 SWG (1.6-3.3)
Pull-out Force from Chassis	10 lb F min (44.4 Newtons)
Probe Withdrawal Force	0.5 lb F min (2.22 Newtons)
Operating Current	2 Amps
Contact Resistance	< 2 m ohms
Temperature Rating	-55°C -- +200°C
Materials	Probe Lug: Brass Socket Lug: Phosphor Bronze
Bushes	Ptfe White (standard), black, red, green, blue, yellow
Lug Plating	P.99 (For plating specification see P. 2)

Fig.	Part No.	Tool No.	Approx. Capacitance m.m.f.	V.RMS 50 Hz		A	B	C	D	E Dia	F Dia	G Dia	J Probe Dia	J1 Probe Lgth
				Nominal Rating	Flashover Sea Level									
32	211-4004			2000	7000	.660	.210		.450	.040	.195	.170		
	111-4001					16.8	5.3		11.5	1.02	4.95	4.32		
32	211-4003			2000	7000	.660	.210		.450	.050	.195	.170		
	111-4001					16.8	5.3		11.5	1.25	4.95	4.32		
32	211-4002			2000	7000	.660	.210		.450	.060	.195	.170		
	111-4001					16.8	5.3		11.5	1.50	4.95	4.32		
33	216-1002	T0549/08	2.00	2000	7000	.640	.290	.150	.200	.040	.195	.156	.040	.210
	116-1002		2.00			16.3	7.4	3.8	5.1	1.02	4.95	3.96	1.02	5.3
33	216-1001	T0549/09	2.00	2000	7000	.640	.290	.150	.200	.050	.195	.156	.050	.210
	116-1001		2.00			16.3	7.4	3.8	5.1	1.25	4.95	3.96	1.25	5.3
33	216-1000	T0549/10	2.00	2000	7000	.640	.290	.150	.200	.060	.195	.156	.060	.210
	116-1000		2.00			16.3	7.4	3.8	5.1	1.50	4.95	3.96	1.50	5.3

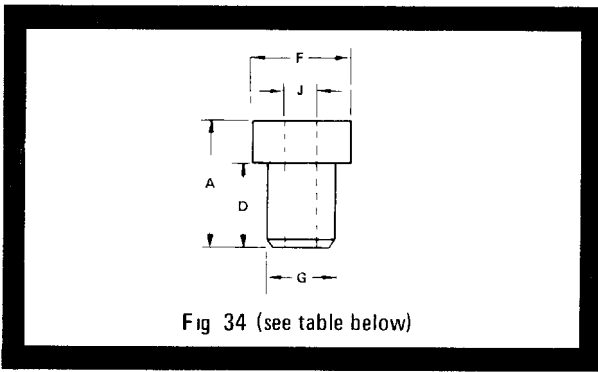

Fig 34 (see table below)

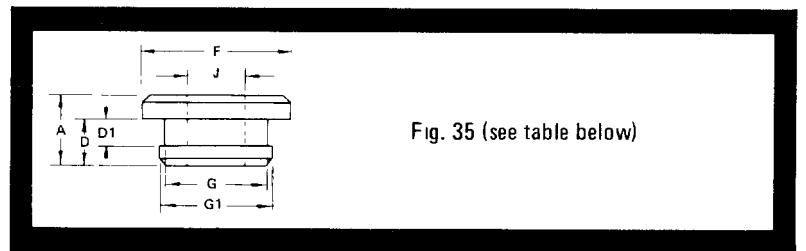
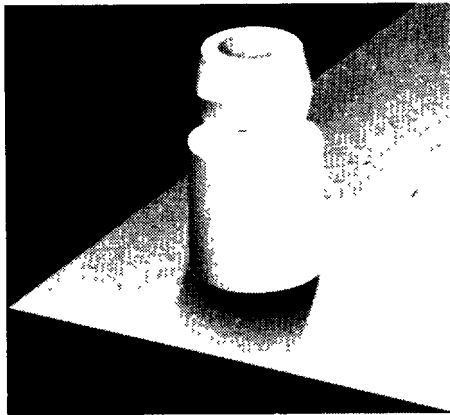

Fig. 35 (see table below)

Part No.	A	D	F	G	J
119-0014	.140	.100	.172	.148	.060
	3.6	2.5	4.4	3.76	1.5
119-0034	.140	.100	.172	.148	.040
	3.6	2.5	4.4	3.76	1.0
119-0039	.160	.120	.172	.148	.073
	4.1	3.0	4.4	3.76	1.9
119-0040	.140	.100	.125	.093	.040
	3.6	2.5	3.2	2.36	1.0
119-0042	.100	.060	.125	.093	.037
	2.5	1.5	3.2	2.36	0.9
119-0046	.225	.185	.218	.185	.120
	5.7	4.7	5.5	4.70	3.0
119-0047	.130	.090	.218	.185	.120
	3.3	2.3	5.5	4.70	3.0
119-0076	.450	.400	.218	.185	.150
	11.4	10.2	5.5	4.70	3.8

Part No.	A	D	D1	F	G	G1	J
119-0016	.104	.069	.040	.218	.154	.164	.099
	2.6	1.8	1.0	5.5	3.91	4.2	2.5
119-0021	.104	.069	.040	.218	.154	.164	.120
	2.6	1.8	1.0	5.5	3.91	4.2	3.0
119-0032	.104	.054	.025	.218	.154	.164	.120
	2.6	1.4	0.6	5.5	3.91	4.2	3.0
119-0036	.125	.075	.060	.218	.154	.164	.120
	3.2	1.9	1.5	5.5	3.91	4.2	3.0
119-0050	.070	.040	.020	.187	.123	.143	.052
	1.8	1.0	0.5	4.7	3.12	3.6	1.3
119-0051	.190	.140	.120	.230	.199	.210	.128
	4.8	3.6	3.0	5.8	5.05	5.3	3.3
119-0069	.140	.105	.075	.218	.154	.164	.120
	3.6	2.7	1.9	5.5	3.91	4.2	3.0

# Ptfe printed circuit board spacer bushings



**Pop!**

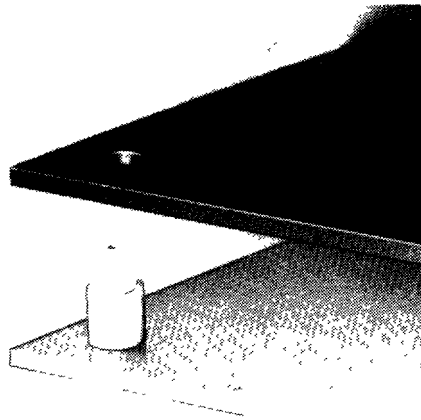

**Snap!**

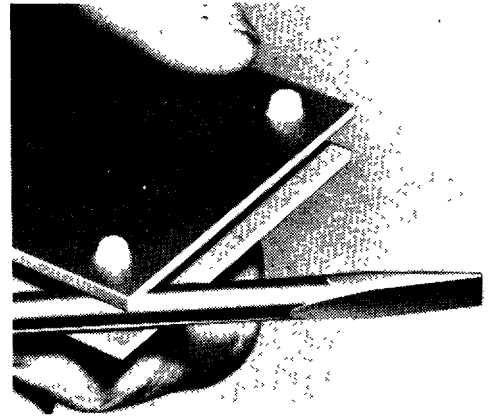

**Click!**

Sealectro Spacer Bushings offer the simplest and fastest way to mount printed circuit boards and cards to metal chassis without nuts, bolts or washers. They provide an economical and mechanically secure mounting device saving costly assembly time.

Insertion in the chassis is a one-step operation. The grommet end of the Spacer Bushing is snapped permanently into a pre-drilled or punched hole with the entrance edge broken. Both edges of the pcb mounting hole should be broken enabling the pcb to be snapped on and off at any time.

Recommended chassis thickness: 0.062" (1.60)  
 Chassis mounting hole dia.: 0.152" ± 0.002"  
 (3.86 ± 0.05)

Note: Break edge of hole on entrance side only  
 Pcb mounting hole dia.: 0.152" ± 0.002"  
 (3.86 ± 0.05)

Note: Break edge of hole on both sides

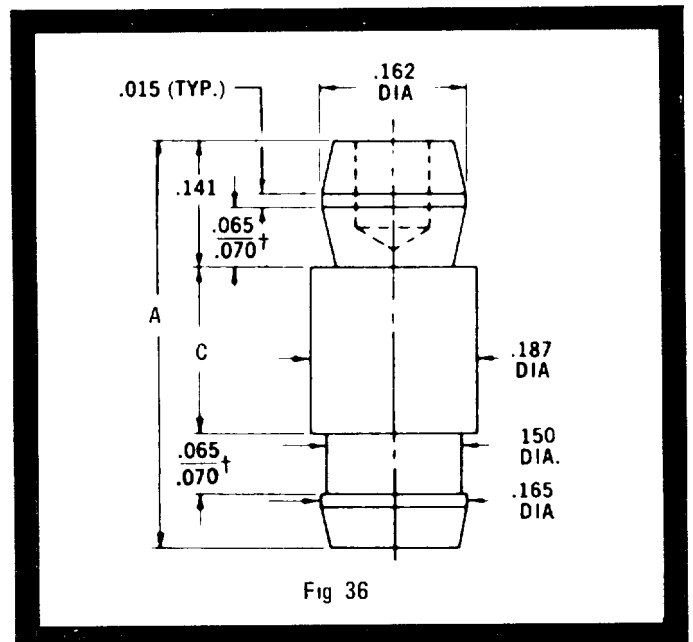

Part Number	Tool Number	A	C	Part Number	Tool Number	A	C	Part Number	Tool Number	A	C
119-0700	B-44-1	.396 10.1	.125 3.2	119-0704	B-44-2	.646 16.4	.375 9.5	119-0708	B-44-3	.896 22.8	.625 15.9
119-0701	B-44-1	.458 11.6	.187 4.7	119-0705	B-44-2	.708 18.0	.437 11.1	119-0709	B-44-4	.958 24.3	.687 17.4
119-0702	B-44-1	.521 13.2	.250 6.4	119-0706	B-44-3	.771 19.6	.500 12.7	119-0710	B-44-4	1.021 25.9	.750 19.1
119-0703	B-44-2	.583 14.8	.312 7.9	119-0707	B-44-3	.833 21.2	.562 14.3				

PRESS-FIT ONE PIECE SERIES  
**Transistor Sockets**

Provides plug-in socket for various TO-18, TO-5 can and circular I.C. packages. Fitted with terminals for circuit connections, the precise contact design provides a positive mechanical grip while making electrical contact with minimum resistance.

<p><b>027-6000</b> 3 lead TO-18</p>	<p><b>027-6007</b> 4 lead TO-18</p>	<p><b>027-6004</b> 3 lead TO-5</p>
<p><b>027-6015</b> 4 lead TO-5</p>	<p><b>027-6013</b> 5 lead TO-5</p>	<p><b>027-6011</b> 6 lead TO-5</p>
<p><b>027-6009</b> 8 lead TO-5</p>	<p><b>027-6017</b> 10 lead 0 23" PCD (TO-5 package)</p>	<p><b>027-6005</b> 12 lead 0 25" PCD (TO-5 package)</p>

PRESS-FIT ONE PIECE SERIES

# Transistor Holders, Bushes & Pads

Provide insulated through chassis lead holes and soldering lugs, support for transistor cans, relief of strain on glass seals and insulation from mounting surfaces.

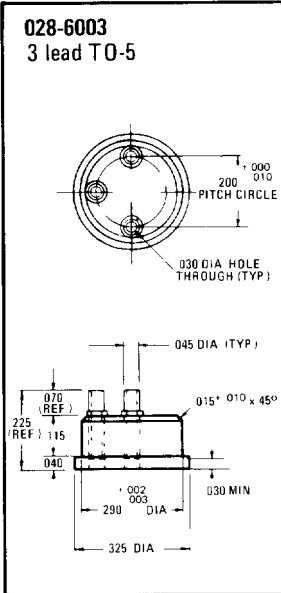
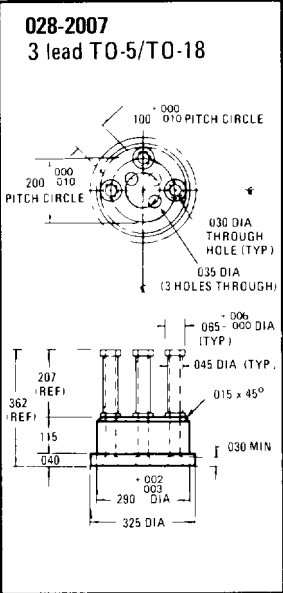
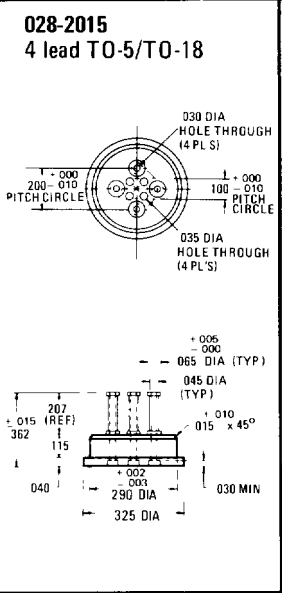
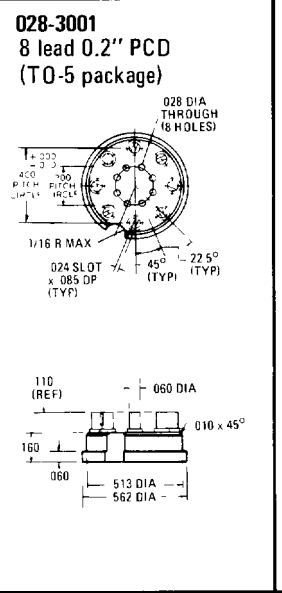
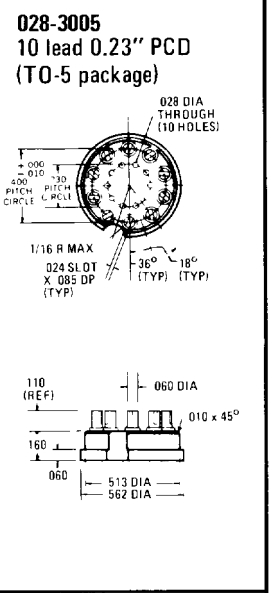
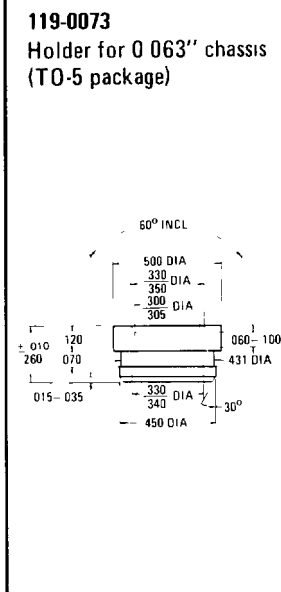
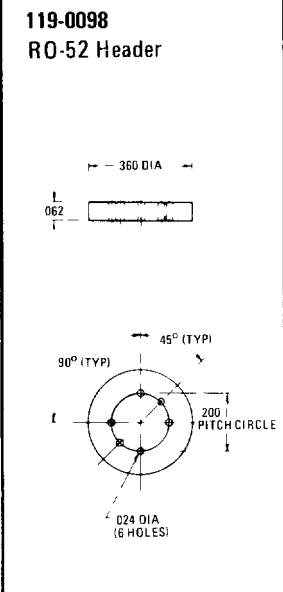
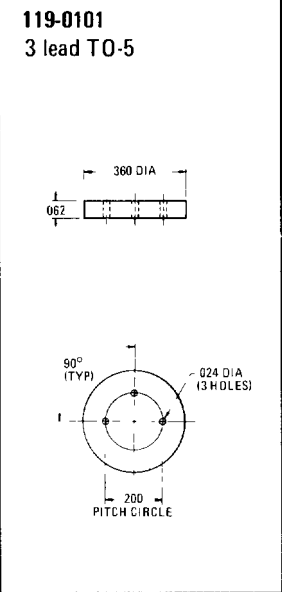
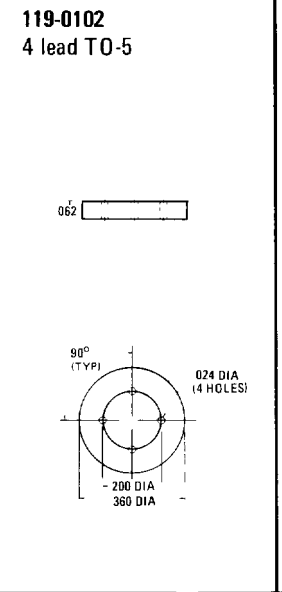
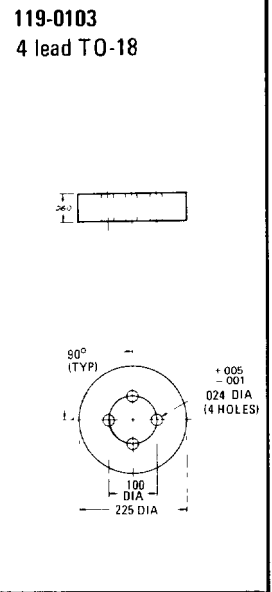
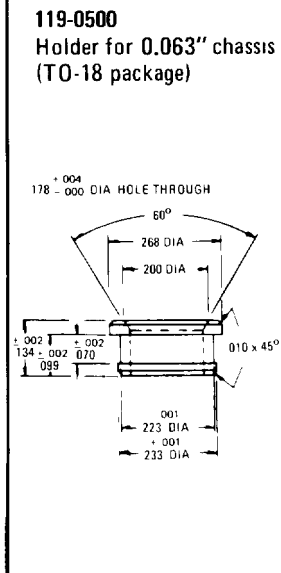
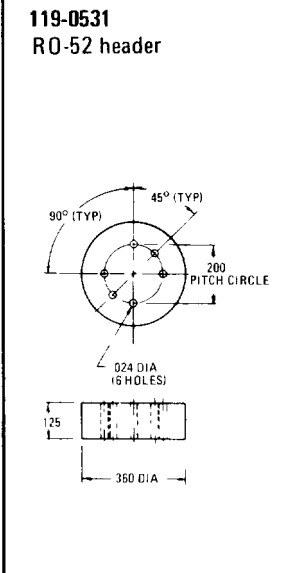
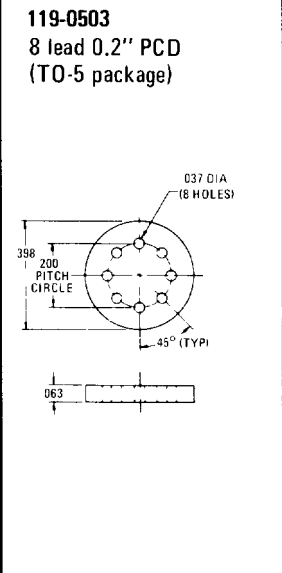
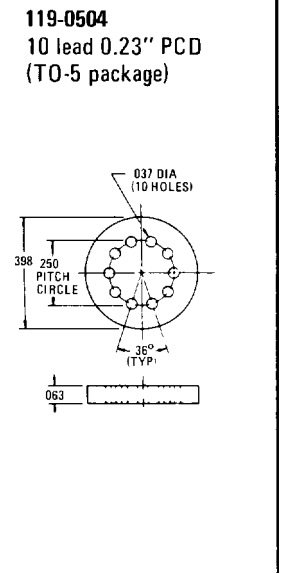
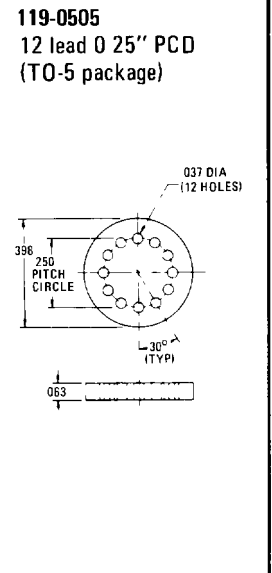
<p><b>028-6003</b> 3 lead TO-5</p> 	<p><b>028-2007</b> 3 lead TO-5/TO-18</p> 	<p><b>028-2015</b> 4 lead TO-5/TO-18</p> 	<p><b>028-3001</b> 8 lead 0.2" PCD (TO-5 package)</p> 	<p><b>028-3005</b> 10 lead 0.23" PCD (TO-5 package)</p> 
<p><b>119-0073</b> Holder for 0.063" chassis (TO-5 package)</p> 	<p><b>119-0098</b> RO-52 Header</p> 	<p><b>119-0101</b> 3 lead TO-5</p> 	<p><b>119-0102</b> 4 lead TO-5</p> 	<p><b>119-0103</b> 4 lead TO-18</p> 
<p><b>119-0500</b> Holder for 0.063" chassis (TO-18 package)</p> 	<p><b>119-0531</b> RO-52 header</p> 	<p><b>119-0503</b> 8 lead 0.2" PCD (TO-5 package)</p> 	<p><b>119-0504</b> 10 lead 0.23" PCD (TO-5 package)</p> 	<p><b>119-0505</b> 12 lead 0.25" PCD (TO-5 package)</p> 

## Other Sealectro Products

### FISCHER MULTIPIN CONNECTORS



Miniature circular electrical connectors with snap lock engagement. Multipin, coaxial, high voltage, high current and thermocouple styles. PTFE or ceramic insulation. Suitable for wide range of cable sizes.

### SMA HIGH PERFORMANCE R.F. CONNECTORS



Sealectro stainless steel SMA series coaxial connectors give excellent VSWR characteristics from DC to 18 GHz. Available with gold plated or passivated finish for flexible or semi-rigid cables.

### CONHEX (SMB, SMC) SUBMINIATURE R.F. CONNECTORS



The widest range of subminiature coaxial connectors in screw-on, snap-on and slide-on styles. Complying with MIL and DEF specifications, Conhex connectors are suitable for every RF application.

### SEAELECTROBOARD PROGRAMMING SYSTEM

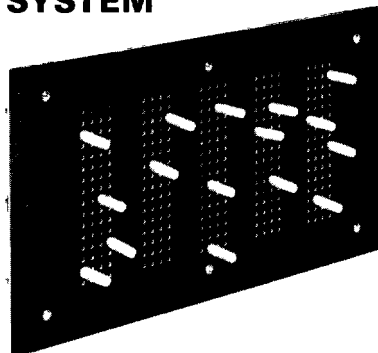

A multiple pole, multiple throw programming system for switching and interconnecting input/output circuits of every type. It comprises an X-Y matrix and up to 4 contact decks in the vertical plane. Interconnection is by means of shorting, skip and component holding pins.

### NON-INSULATED TERMINALS

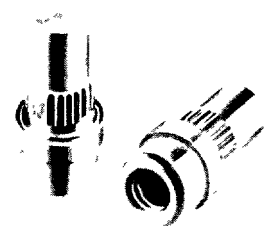

Pin jacks, shorting links and Bullet Nose terminal pins in a wide variety of configurations for PC boards, multi-layer and flex circuits.