

1. SCOPE

1.1 Scope. This drawing describes device requirements for class B microcircuits in accordance with 1.2.1 of MIL-STD-883, "Provisions for the use of MIL-STD-883 in conjunction with compliant non-JAN devices".

1.2 Part number. The complete part number shall be as shown in the following example:

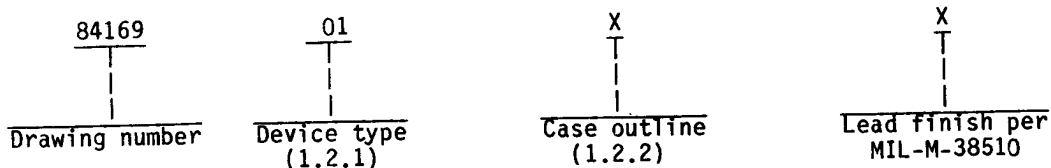

1.2.1 Device types. The device types shall identify the circuit function as follows:

Device type	Generic number	Frequency	Circuit function
01	F9450	15.0 MHz	16-bit microprocessor with MIL-STD-1750 instruction set architecture
02	F9450	18.0 MHz	16-bit microprocessor with MIL-STD-1750 instruction set architecture
03	F9450	20.0 MHz	16-bit microprocessor with MIL-STD-1750 instruction set architecture
04	F9450	15.0 MHz	16-bit microprocessor with MIL-STD-1750 instruction set architecture

1.2.2 Case outlines. The case outlines shall be as designated in appendix C of MIL-M-38510, and as follows:

Outline letter	Case outline
X	64-lead (1.650" x .583" x .180"), dual-in-line package (see figure 1)
Y	64-lead (1.650" x .583" x .180"), gull wing package (see figure 1)

1.3 Absolute maximum ratings.

Storage temperature range	- - - - -	-65°C to +150°C
VCC pin potential to ground pin	- - - - -	-0.5 V dc to +6.0 V dc
Input voltage range	- - - - -	-0.5 V dc to +5.5 V dc
Input current range	- - - - -	-20 mA to +5 mA
Output voltage range (output high)	- - - - -	-0.5 V dc to +5.5 V dc
Output current (output low)	- - - - -	+20 mA
Injector current (I _{INJ})	- - - - -	1.8 A
Maximum power dissipation (P _D):		
Device type 01	- - - - -	3.94 W
Device types 02, 03, and 04	- - - - -	4.26 W
Thermal resistance, junction-to-case (θ _{JC})	- - - - -	2.5°C/W

1.4 Recommended operating conditions.

Supply voltage range (V _{CC})	- - - - -	4.75 V dc minimum to 5.25 V dc maximum
Injector current range (I _{INJ}):		
Device types 01 and 04	- - - - -	.98 A minimum to 1.22 A maximum
Device type 02	- - - - -	.98 A minimum to 1.28 A maximum
Device type 03	- - - - -	1.04 A minimum to 1.28 A maximum
Case operating temperature range (T _C)	- - - - -	-55°C to +125°C

STANDARDIZED MILITARY DRAWING DEFENSE ELECTRONICS SUPPLY CENTER DAYTON, OHIO 45444	SIZE A	84169
	REVISION LEVEL A	SHEET 2

2. APPLICABLE DOCUMENTS

2.1 Government specification and standards. Unless otherwise specified, the following specification and standards, of the issue listed in that issue of the Department of Defense Index of Specifications and Standards specified in the solicitation, form a part of this drawing to the extent specified herein.

SPECIFICATION

MILITARY

MIL-M-38510 - Microcircuits, General Specification for.

STANDARDS

MILITARY

MIL-STD-883 - Test Methods and Procedures for Microelectronics.
 MIL-STD-1750 - Airborne Computer Instruction Set Architecture.

(Copies of the specification and standards required by manufacturers in connection with specific acquisition functions should be obtained from the contracting activity or as directed by the contracting activity.)

2.2 Order of precedence. In the event of a conflict between the text of this drawing and the references cited herein, the text of this drawing shall take precedence.

3. REQUIREMENTS

3.1 Item requirements. The individual item requirements shall be in accordance with 1.2.1 of MIL-STD-883, "Provisions for the use of MIL-STD-883 in conjunction with compliant non-JAN devices" and as specified herein.

3.2 Design, construction, and physical dimensions. The design, construction, and physical dimensions shall be as specified in MIL-M-38510 and herein.

3.2.1 Case outlines. The case outlines shall be in accordance with 1.2.2 and figure 1 herein.

3.2.2 Terminal connections. The terminal connections shall be as specified on figure 2.

3.2.3 Functional block diagram. The functional block diagram shall be as specified on figure 3.

3.3 Electrical performance characteristics. Unless otherwise specified, the electrical performance characteristics are as specified in table I and apply over the full case operating temperature range.

3.4 Marking. Marking shall be in accordance with MIL-STD-883 (see 3.1 herein). The part shall be marked with the part number listed in 1.2 herein. In addition, the manufacturer's part number may also be marked as listed in 6.5 herein.

3.5 Certificate of compliance. A certificate of compliance shall be required from a manufacturer in order to be listed as an approved source of supply in 6.5. The certificate of compliance submitted to DESC-ECS prior to listing as an approved source of supply shall state that the manufacturer's product meets the requirements of MIL-STD-883 (see 3.1 herein) and the requirements herein.

3.6 Certificate of conformance. A certificate of conformance as required in MIL-STD-883 (see 3.1 herein) shall be provided with each lot of microcircuits delivered to this drawing.

STANDARDIZED MILITARY DRAWING DEFENSE ELECTRONICS SUPPLY CENTER DAYTON, OHIO 45444	SIZE A	84169
	REVISION LEVEL A	SHEET 3

TABLE I. Electrical performance characteristics.

Test	Symbol	Conditions -55°C T _C instant on to +125°C T _C operating V _{CC} = 5.0 V ±5% unless otherwise specified	Device type	Group A subgroups	Limits		Unit
					Min	Max	
Input high level	V _{IH}	Guaranteed input high	A11	1,2,3	2.0		V
Input high level (CPU CLK input only)					2.2		
Input low level	V _{IL}	Guaranteed input low	A11	1,2,3		0.8	V
Positive-going threshold voltage USR ₀ INT-USR ₅ INT, SYSFLT ₀ , SYSFLT ₁ , PWRDN INT	V _{T+}	V _{CC} = 5.0 V I _{INJ} = 1.1 A	A11	1,2,3	1.5	2.0	V
Negative-going threshold voltage USR ₀ INT-USR ₅ INT, SYSFLT ₀ , SYSFLT ₁ , PWRDN INT	V _{T-}	V _{CC} = 5.0 V I _{INJ} = 1.1 A	A11	1,2,3	0.6	1.1	V
Input clamp voltage	V _{CD}	I _{IN} = -18 mA V _{CC} = 4.75 V I _{INJ} = 1.1 A	A11	1,2,3		-1.5	V
Output high voltage	V _{OH}	I _{OH} = -0.4 mA V _{CC} = 4.75 V I _{INJ} = 1.1 A	A11	1,2,3	2.4		V
Output low voltage	V _{OL}	I _{OL} = 8.0 mA V _{CC} = 4.75 V I _{INJ} = 1.1 A	A11	1,2,3		0.5	V
Input high current IB ₀ -IB ₁₅ , BUS BUSY, BUS LOCK	I _{IH1}	V _{IN} = 2.7 V, V _{CC} = 5.25 V I _{INJ} = 1.1 A	A11	1,2,3		40	μA
Input high current except IB ₀ -IB ₁₅ , BUS BUSY, BUS LOCK	I _{IH2}	V _{IN} = 2.7 V, V _{CC} = 5.25 V I _{INJ} = 1.1 A	A11	1,2,3		100	μA
Input high current all inputs	I _{IH3}	V _{IN} = 5.25 V, V _{CC} = 5.25 V I _{INJ} = 1.1 A	A11	1,2,3		1.0	mA

See footnotes at end of table.

STANDARDIZED MILITARY DRAWING DEFENSE ELECTRONICS SUPPLY CENTER DAYTON, OHIO 45444	SIZE A	84169
	REVISION LEVEL A	SHEET 4

DESC FORM 193A
SEP 87

* U. S. GOVERNMENT PRINTING OFFICE: 1988-549-904

TABLE I. Electrical performance characteristics - Continued.

Test	Symbol	Conditions -55°C T _C instant on to +125°C T _C operating V _{CC} = 5.0 V ±5% unless otherwise specified	Device type	Group A subgroups	Limits		Unit	
					Min	Max		
Input low current	I _{IL}	V _{IN} = 0.4 V V _{CC} = 5.25 V I _{INJ} = 1.1 A	A11	1,2,3		-400	μA	
Output 3-state current IB ₀ -IB ₁₅ , BUS BUSY, BUS LOCK	I _{OZH1}	V _{OUT} = 2.4 V V _{CC} = 5.25 V	I _{INJ} = 1.1 A	01,04	1,2,3	140	μA	
			I _{INJ} = 1.16 A	02,03				
Output 3-state current AK ₀ -AK ₃ , AS ₀ , AS ₃ , R/W, M/I ₀ , D/I, STRBA, STRBD	I _{OZH2}	V _{OUT} = 2.4 V V _{CC} = 5.25 V	I _{INJ} = 1.1 A	01,04	1,2,3	100	μA	
			I _{INJ} = 1.16 A	02,03				
Output 3-state current IB ₀ -IB ₁₅ , BUS BUSY, BUS LOCK	I _{OZL1}	V _{OUT} = 0.5 V V _{CC} = 5.25 V	I _{INJ} = 1.1 A	01,04	1,2,3	-500	μA	
			I _{INJ} = 1.16 A	02,03				
Output 3-state current AK ₀ -AK ₃ , AS ₀ , AS ₃ , R/W, M/I ₀ , D/I, STRBA, STRBD	I _{OZL2}	V _{OUT} = 0.5 V V _{CC} = 5.25 V	I _{INJ} = 1.1 A	01,04	1,2,3	-100	μA	
			I _{INJ} = 1.16 A	02,03				
Output short circuit (not more than one output shorted at one time)	I _{OSH}	V _{OUT} = 0 V V _{CC} = 5.25 V	I _{INJ} = 1.1 A	01,04	1,2,3	-15	-125	mA
			I _{INJ} = 1.16 A	02,03				
Power supply current	I _{CC}	V _{CC} = 5.25 V T _C = -55°C	I _{INJ} = 1.1 A	01	1,2,3	390	mA	
			I _{INJ} = 1.16 A	02,03, 04		450		
		V _{CC} = 5.25 V T _C = +125°C	I _{INJ} = 1.1 A	01	1,2,3	260		
			I _{INJ} = 1.16 A	02,03, 04		290		

See footnotes at end of table.

STANDARDIZED MILITARY DRAWING DEFENSE ELECTRONICS SUPPLY CENTER DAYTON, OHIO 45444	SIZE A		84169
		REVISION LEVEL A	SHEET 5

TABLE I. Electrical performance characteristics - Continued.

Test	Symbol	Conditions -55°C T _C instant on to +125°C T _C operating V _{CC} = 5.0 V ±5% unless otherwise specified	Device type	Group A subgroups	Limits		Unit
					Min	Max	
Injector voltage <u>1/</u>	V _{INJ}	V _{CC} = 5.25 V <u>1/</u>	I _{INJ} = 0.98 A	01,02,04	1,2,3	1.2	1.43
			I _{INJ} = 1.04 A	03			
		V _{CC} = 5.25 V <u>1/</u>	I _{INJ} = 1.22 A	01,04	1,2,3	1.34	1.55
			I _{INJ} = 1.28 A	02,03			
Propagation delay from clock							
M/I ₀ , D/I, R/W, AS ₀ - AS ₃ , AK ₀ -AK ₃ (status)	t _c (M)	See figure 4 <u>2/</u>	01	9,10,11		60	ns
			02,03,04				
BUS REQ	t _c (BR)		01	9,10,11		45	
			02,03,04				
BUS BUSY	t _c (BB)		01	9,10,11		55	
			02,03,04				
BUS BUSY, three-state	t _c (BB)z		01	9,10,11		35	
			02,03,04				
BUS LOCK	t _c (BL)		01	9,10,11		50	
			02,03,04				
BUS LOCK, three-state	t _c (BL)z		01	9,10,11		40	
			02,03,04				
IB ₀ -IB ₁₅ address	t _c (IBA)v		01	9,10,11		65	
			02,03,04				
IB ₀ -IB ₁₅ address, three-state	t _c (IBA)z		01	9,10,11		75	
			02,03,04				
STRBA low	t _c (SA)1		01	9,10,11		25	
			02,03,04				

See footnotes at end of table.

STANDARDIZED MILITARY DRAWING DEFENSE ELECTRONICS SUPPLY CENTER DAYTON, OHIO 45444	SIZE A	84169
	REVISION LEVEL A	SHEET 6

DESC FORM 193A
SEP 87

* U. S. GOVERNMENT PRINTING OFFICE: 1988-549-904

TABLE I. Electrical performance characteristics - Continued.

Test	Symbol	Conditions -55°C T _C instant on to +125°C T _C operating V _{CC} = 5.0 V ±5% unless otherwise specified	Device type	Group A subgroups	Limits		Unit
					Min	Max	
Propagation delay from clock - continued							
STRBA high	t _{C(SA)h}	See figure 4 2/	A11	9,10,11		35	ns
STRBA, three-state	t _{C(SA)z}		01	9,10,11		40	
			02,03,04			30	
IB ₀ -IB ₁₅ data	t _{C(IBD)v}		01	9,10,11		60	
			02,03,04			55	
IB ₀ -IB ₁₅ data, three-state	t _{C(IBD)z}		01	9,10,11		45	
			02,03,04			40	
STRBD low (read)	t _{C(SDr)l}		01	9,10,11		85	
			02,03,04			65	
STRBD high (read)	t _{C(SDr)h}		01	9,10,11		45	
			02,03,04			35	
STRBD low (write)	t _{C(SDw)l}		01	9,10,11		50	
			02,03,04			40	
STRBD high (write)	t _{C(SDw)h}		01	9,10,11		40	
			02,03,04			35	
STRBD three-state	t _{C(SD)z}		01	9,10,11		40	
		02,03,04			35		
SNEW	t _{C(SNW)}	01	9,10,11		75		
		02,03,04			65		
TRIGO RST	t _{C(TG0)}	01	9,10,11		70		
		02,03,04			60		
DMA EN	t _{C(DME)}	01	9,10,11		60		
		02,03,04			50		

See footnotes at end of table.

STANDARDIZED MILITARY DRAWING DEFENSE ELECTRONICS SUPPLY CENTER DAYTON, OHIO 45444	SIZE A	84169
	REVISION LEVEL A	SHEET 7

DESC FORM 193A
SEP 87

* U. S. GOVERNMENT PRINTING OFFICE: 1988-549-904

TABLE I. Electrical performance characteristics - Continued.

Test	Symbol	Conditions -55°C T _C instant on to +125°C T _C operating V _{CC} = 5.0 V ±5% unless otherwise specified	Device type	Group A subgroups	Limits		Unit
					Min	Max	

Propagation delay from clock - continued

NML PWRUP	t _C (NPU)	See figure 4 2/	01	9,10,11		70	ns
			02,03,04			60	
MAJ ER, UNRCV ER	t _C (ER)		01	9,10,11		100	
			02,03,04			85	
Status three-state	t _C (M)z		A11	9,10,11		40	

Other timing parameters

STRBD pulse width, write cycle 3/	t _{SD1} (SD)h	See figure 4 2/	01	9,10,11		55	ns
			02			50	
			03			45	
			04			60	
DATA valid to STRBD high (write) 3/	t _{BDv} (SDw)h		01,04	9,10,11		90	
			02			80	
			03			70	
ADDRESS valid to STRBA low 3/	t _{BAv} (SA)1		01	9,10,11		10	
			02			5	
			03,04			5	
ADDRESS valid after STRBA hold time 3/	t _{SA1} (IBA)x		A11	9,10,11		5	
Status valid to STRBA low 3/	t _{Mv} (SA)1		01	9,10,11		20	
			02,03,04			10	
STRBD high (write) to DATA invalid	t _{SDwh} (IBD)x		A11	9,10,11		40	
DATA don't care to STRBD high (read)	t _{IBDx} (SDr)h		A11	9,10,11		0	

See footnotes at end of table.

STANDARDIZED MILITARY DRAWING DEFENSE ELECTRONICS SUPPLY CENTER DAYTON, OHIO 45444	SIZE A		84169
		REVISION LEVEL A	SHEET 8

DESC FORM 193A
SEP 87

* U. S. GOVERNMENT PRINTING OFFICE: 1988-549-904

TABLE I. Electrical performance characteristics - Continued.

Test	Symbol	Conditions -55°C T _C instant on to +125°C T _C operating V _{CC} = 5.0 V ±5% unless otherwise specified	Device type	Group A subgroups	Limits		Unit
					Min	Max	
Other timing parameters - continued							
Memory or I/O system time <u>4/</u>	t _{MEM}	See figure 4 <u>2/</u>	01,04	9,10,11	135		ns
			02		105		
			03		90		
Pulse width, edge- sensitive Fault or Interrupt	t _{F(F),t_{l(1)}}		A11	9,10,11		30	
Setup time before clock (unless otherwise specified)							
RDYA	t _{RAV(C)}	See figure 4 <u>2/</u>	A11	9,10,11		30	ns
RDYD	t _{RDV(C)}		A11	9,10,11		30	
IB ₀ -IB ₁₅ data in	t _{IBDV(C)}		01	9,10,11		0	
			02,03,04			5	
CON REQ	t _{REQV(C)}		A11	9,10,11		0	
RESET	t _{RSV(C)}		01	9,10,11		10	
			02,03,04			20	
BUS LOCK	t _{BLV(C)}		A11	9,10,11		25	
BUS GNT	t _{BGV(C)}		A11	9,10,11		25	
PWRDN INT, USR INT (level-sense)	t _{IRV(C)}		A11	9,10,11		15	

See footnotes at end of table.

STANDARDIZED MILITARY DRAWING DEFENSE ELECTRONICS SUPPLY CENTER DAYTON, OHIO 45444	SIZE A	84169
	REVISION LEVEL A	SHEET 9

TABLE I. Electrical performance characteristics - Continued.

Test	Symbol	Conditions -55°C T _C instant on to +125°C T _C operating V _{CC} = 5.0 V ±5% unless otherwise specified	Device type	Group A subgroups	Limits		Unit
					Min	Max	
Setup time before clock (unless otherwise specified) - continued							
Level-sensitive faults (before external BUS BUSY)	t _{Fv(BB)} h	See figure 4 2/	01	9,10,11		70	ns
			02,03,04			60	
Level-sensitive fault, MEM PRT ER, EXT ADR ER	t _{Fv(C)}		A11	9,10,11		35	
IOL ₁ INT, IOL ₂ INT	t _{IRLv(C)}		A11	9,10,11		0	
PAR ER load FT, generate UNRCV ER	t _{PARv(C)}		01	9,10,11		5	
			02,03,04			10	
PAR ER inhibit register load			01	9,10,11		20	
			02,03,04			10	
Hold time after clock (unless otherwise specified)							
RDYA	t _{C(RA)}	See figure 4 2/	A11	9,10,11		0	ns
RDYD	t _{C(RD)x}		A11	9,10,11		0	
IB ₀ -IB ₁₅ data in	t _{C(IBD)x}		01	9,10,11		25	
			02,03,04			20	
CON REQ	t _{C(REQ)x}		01	9,10,11		40	
			02,03,04			35	
RESET	t _{C(RS)x}		01	9,10,11		15	
			02,03,04			20	
BUS LOCK	t _{C(BL)x}		A11	9,10,11		0	

See footnotes at end of table.

STANDARDIZED MILITARY DRAWING DEFENSE ELECTRONICS SUPPLY CENTER DAYTON, OHIO 45444	SIZE A		84169
		REVISION LEVEL A	SHEET 10

DESC FORM 193A
SEP 87

* U. S. GOVERNMENT PRINTING OFFICE: 1968-549-904

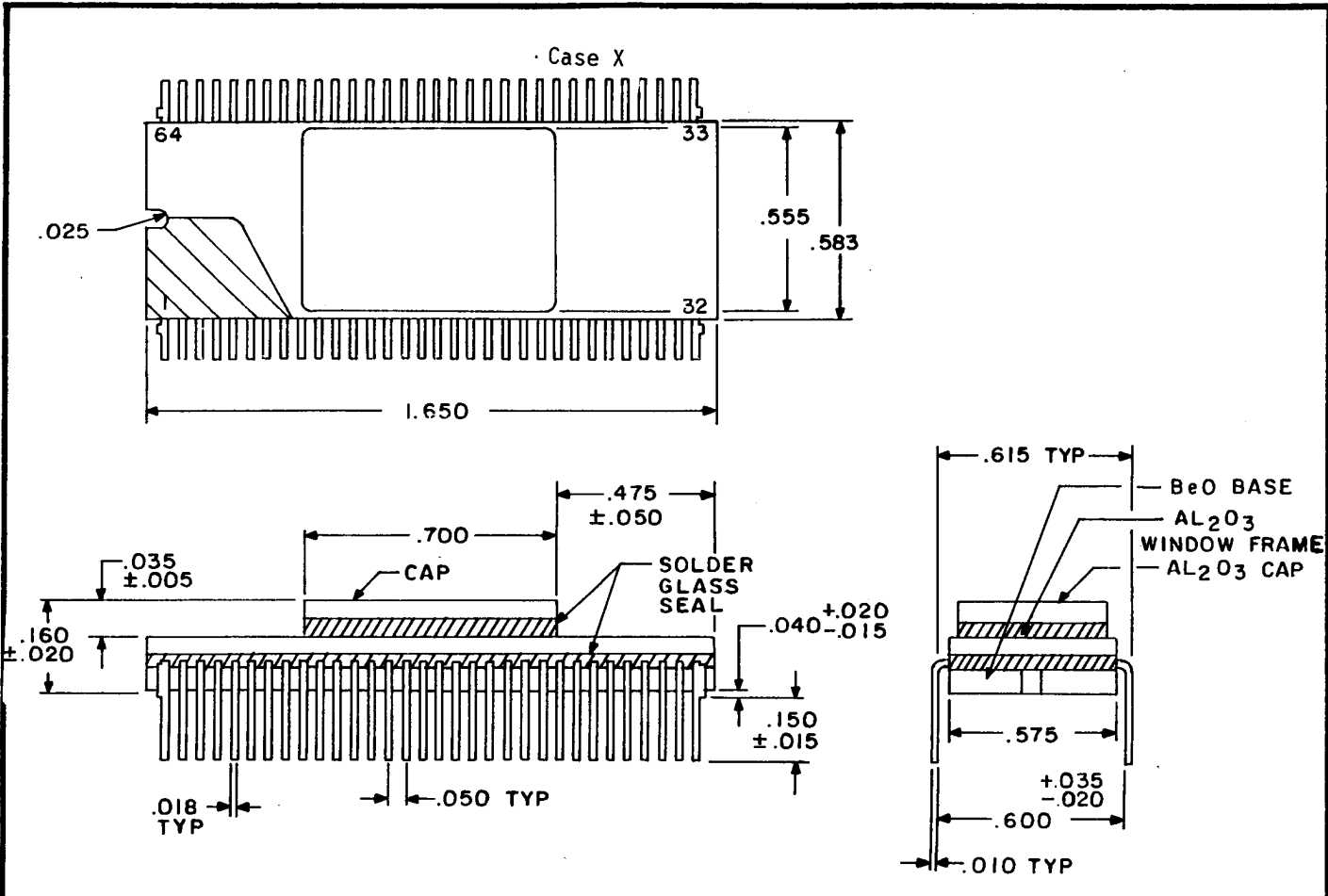

Inches	mm
.005	0.13
.010	0.25
.015	0.38
.018	0.46
.020	0.51
.025	0.64
.035	0.89
.040	1.02
.050	1.27
.150	3.81
.160	4.06
.475	12.08
.555	14.10
.575	14.61
.583	14.81
.600	15.24
.615	15.62
.700	17.78
1.650	41.91

NOTES:

- All dimensions are in inches.
- Lead finish: Hot solder dip in accordance with MIL-M-38510.
- Cap is ceramic.
- Base is BeO.
- Package weight is 8.5 grams.
- A pin one identification mark shall be located adjacent to pin one and shall be located in the shaded area shown.
- The letters "BeO" shall be located adjacent to pin 64.
- Dimension tolerances ±.010 inch unless otherwise shown.

FIGURE 1. Case outlines.

STANDARDIZED MILITARY DRAWING DEFENSE ELECTRONICS SUPPLY CENTER DAYTON, OHIO 45444	SIZE A		84169
		REVISION LEVEL A	SHEET 12

DESC FORM 193A
SEP 87

★ U. S. GOVERNMENT PRINTING OFFICE: 1968-550-547

Case Y

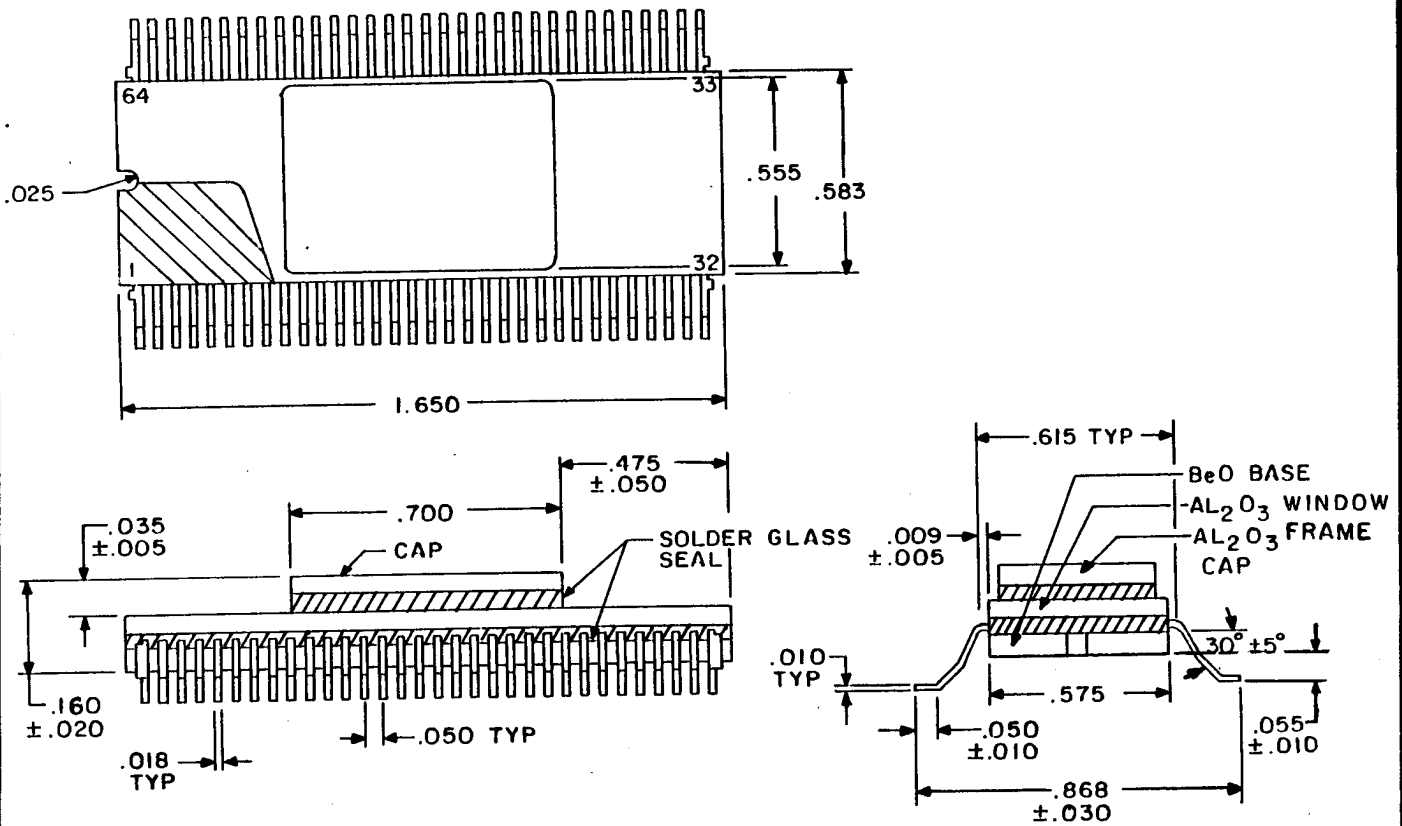

Inches	mm
.005	0.13
.009	0.23
.010	0.25
.018	0.46
.020	0.51
.025	0.64
.030	0.76
.035	0.89
.050	1.27
.055	1.40
.100	2.54
.475	12.08
.555	14.10
.575	14.61
.583	14.81
.615	15.62
.700	17.78
.868	22.05
1.650	41.91

NOTES:

- All dimensions are in inches.
- Lead finish: Hot solder dip in accordance with MIL-M-38510.
- Cap is ceramic.
- Base is BeO.
- Package weight is 8.5 grams.
- Plane of lead "feet" parallel to bottom surface of BeO base ±5°.
- A pin one identification mark shall be located adjacent to pin one and shall be located in the shaded area shown.
- The letters "BeO" shall be located adjacent to pin 64.
- Dimension tolerances ±.010 inch unless otherwise stated.

FIGURE 1. Case outlines - Continued.

STANDARDIZED MILITARY DRAWING DEFENSE ELECTRONICS SUPPLY CENTER DAYTON, OHIO 45444	SIZE A		84169
		REVISION LEVEL A	SHEET 13

DESC FORM 193A
SEP 87

* U. S. GOVERNMENT PRINTING OFFICE: 1988-550-547

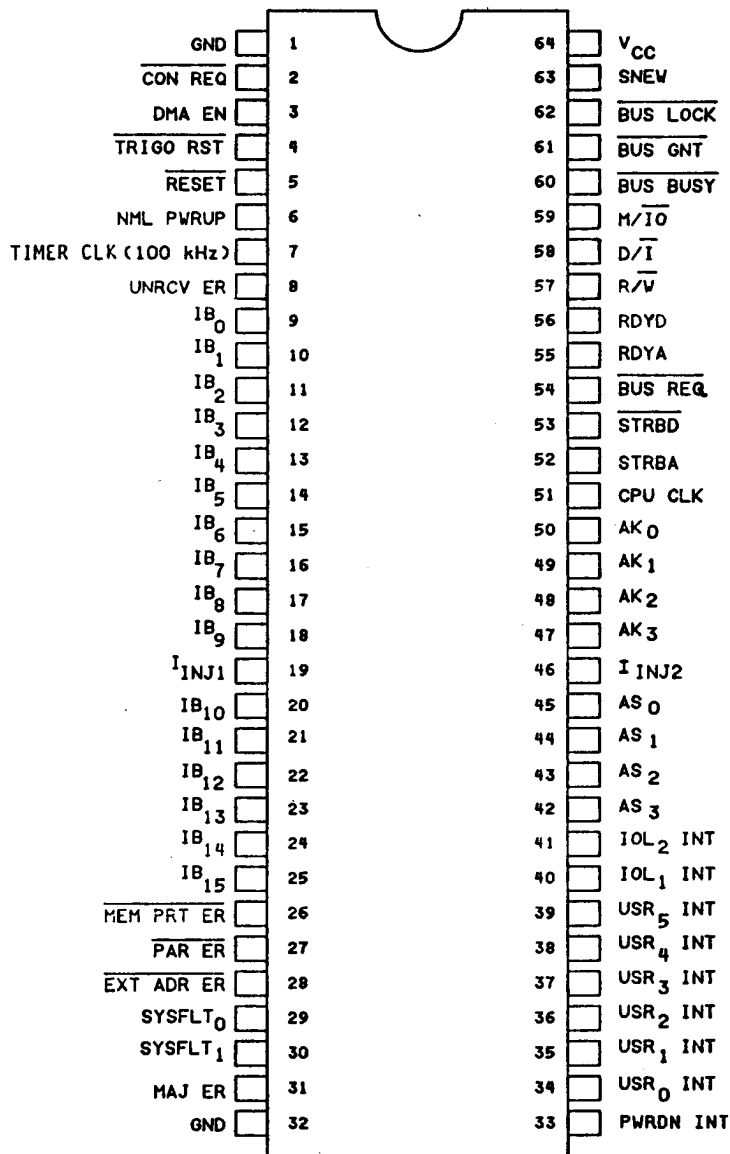

FIGURE 2. Terminal connections.

STANDARDIZED MILITARY DRAWING DEFENSE ELECTRONICS SUPPLY CENTER DAYTON, OHIO 45444	SIZE A		84169
		REVISION LEVEL A	SHEET 14

DESC FORM 193A
SEP 87

☆ U. S. GOVERNMENT PRINTING OFFICE: 1988-550-547

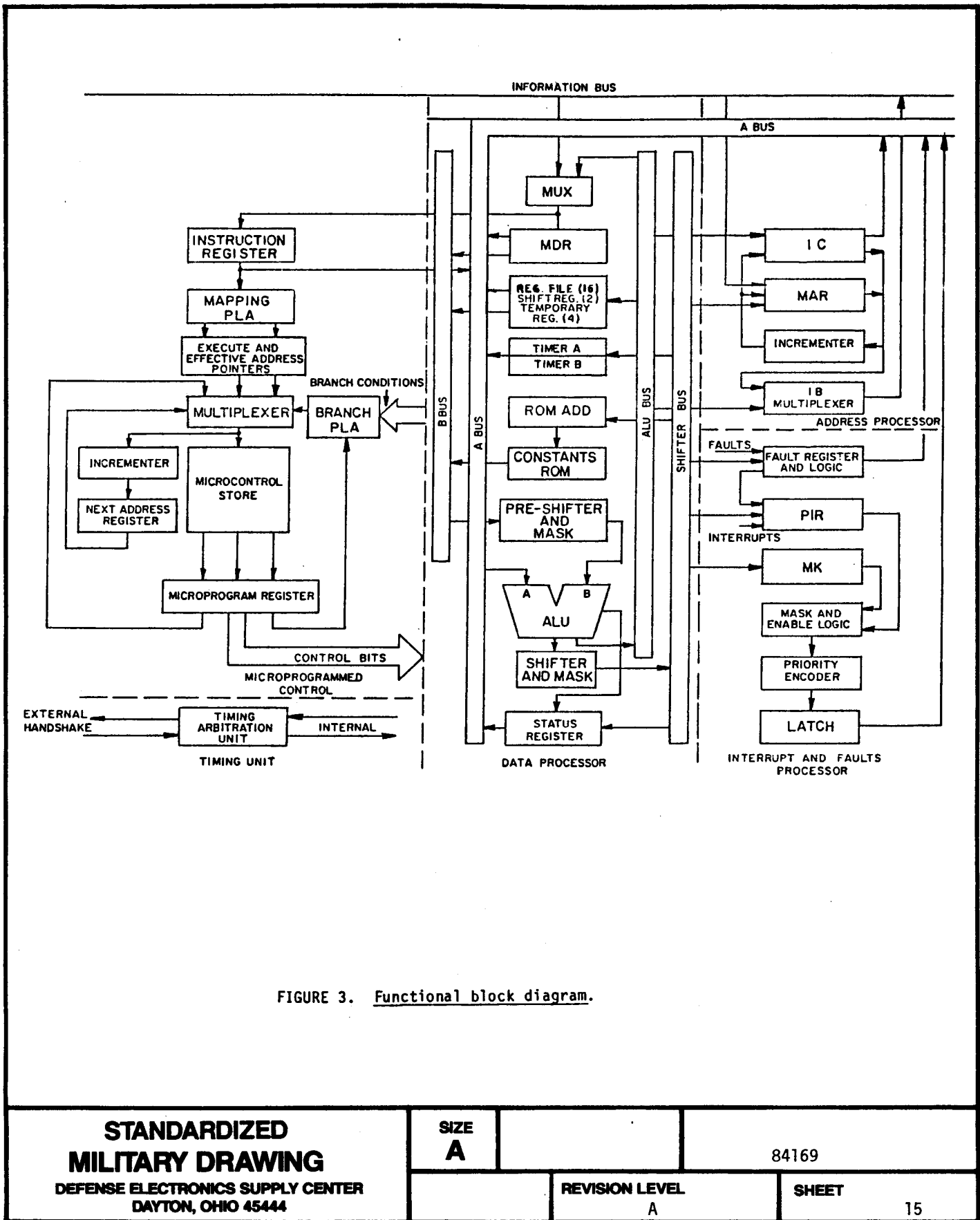

FIGURE 3. Functional block diagram.

**STANDARDIZED
MILITARY DRAWING**
DEFENSE ELECTRONICS SUPPLY CENTER
DAYTON, OHIO 45444

SIZE
A

84169

REVISION LEVEL
A

SHEET
15

MINIMUM READ BUS CYCLE TIMING DIAGRAM

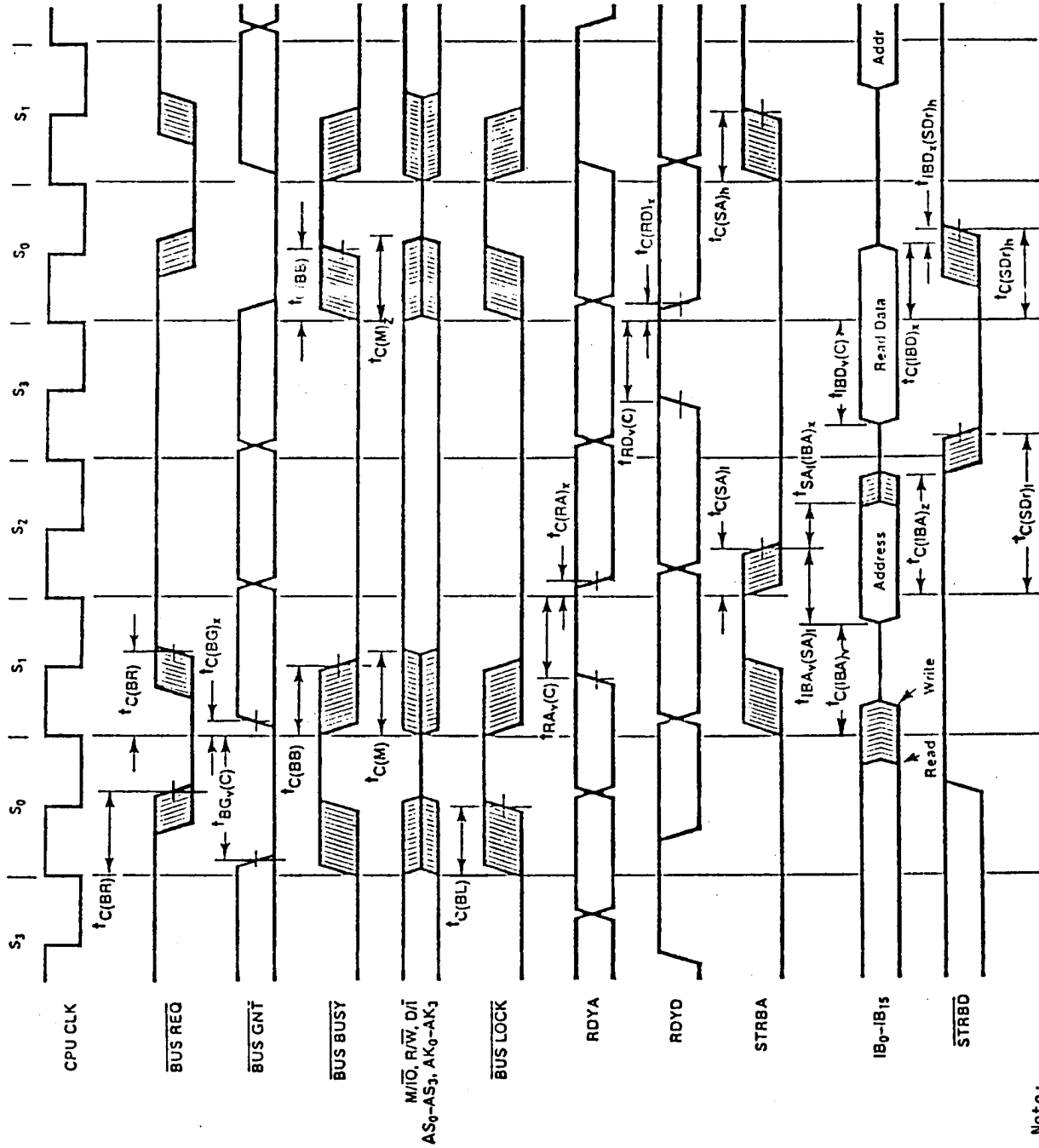

Note:
Shown are three consecutive bus cycles, only one bus master.

FIGURE 4. Timing waveforms.

**STANDARDIZED
MILITARY DRAWING**

DEFENSE ELECTRONICS SUPPLY CENTER
DAYTON, OHIO 45444

SIZE
A

84169

REVISION LEVEL
A

SHEET

16

MINIMUM WRITE BUS CYCLE TIMING DIAGRAM

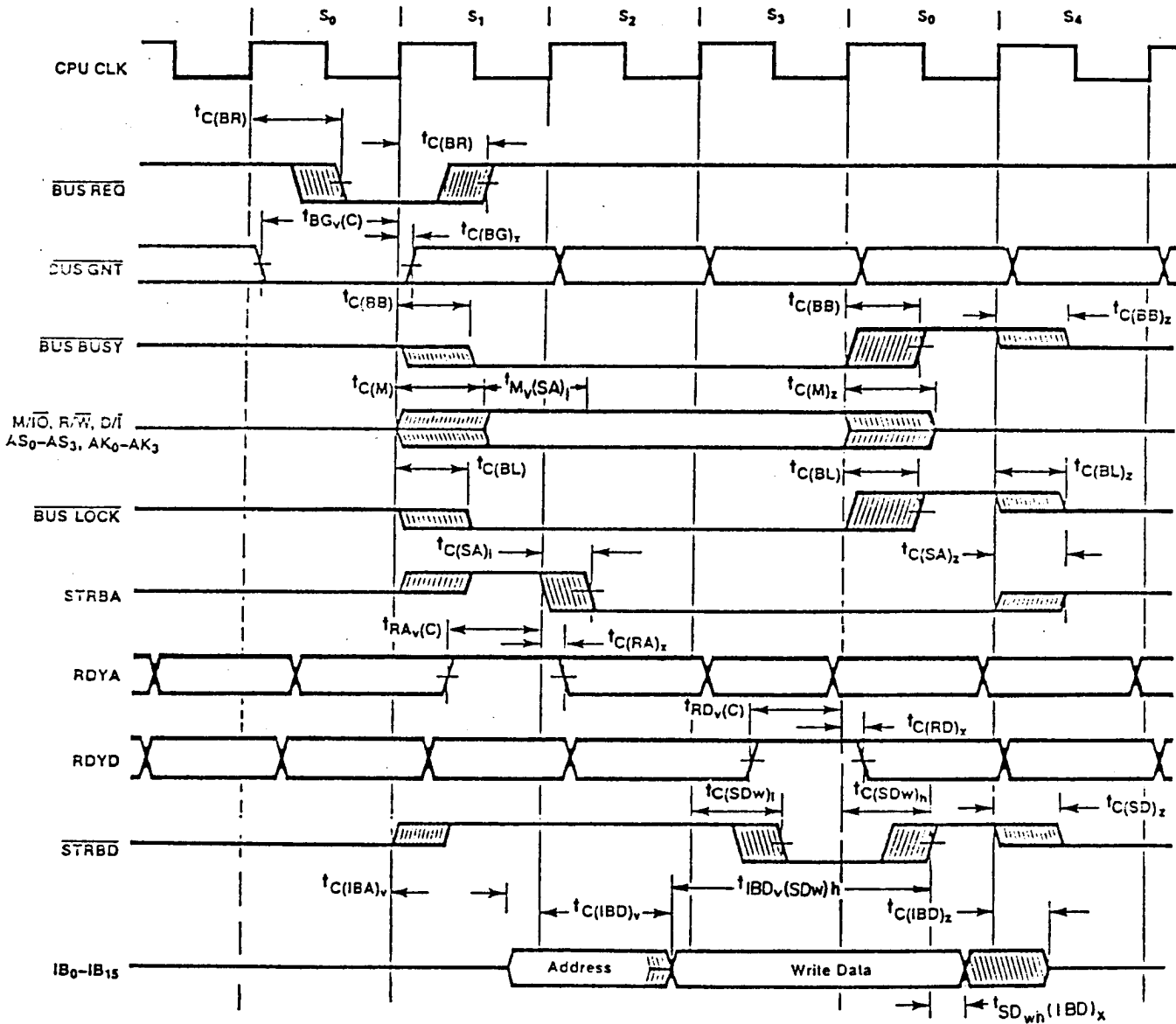

NOTES:

1. Shown is a single isolated bus cycle, only one bus master.
2. An intermediate level indicates that the CPU has placed this signal in a three-state condition.

FIGURE 4. Timing waveforms - Continued.

STANDARDIZED MILITARY DRAWING DEFENSE ELECTRONICS SUPPLY CENTER DAYTON, OHIO 45444	SIZE A	84169
	REVISION LEVEL A	SHEET 17

DESC FORM 193A
SEP 87

* U. S. GOVERNMENT PRINTING OFFICE: 1988-550-547

RDYD SIGNAL - WRITE BUS CYCLE TIMING DIAGRAM

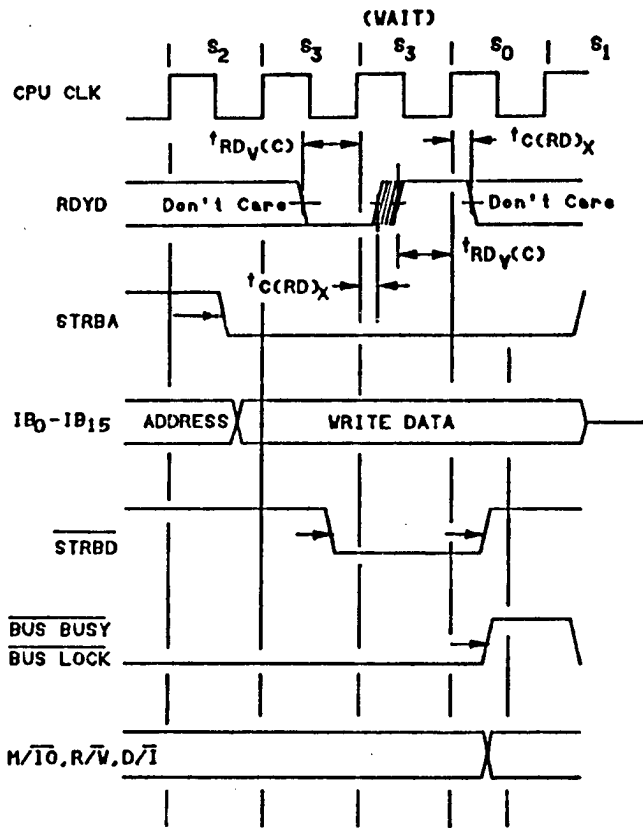

RDYA SIGNAL TIMING DIAGRAM

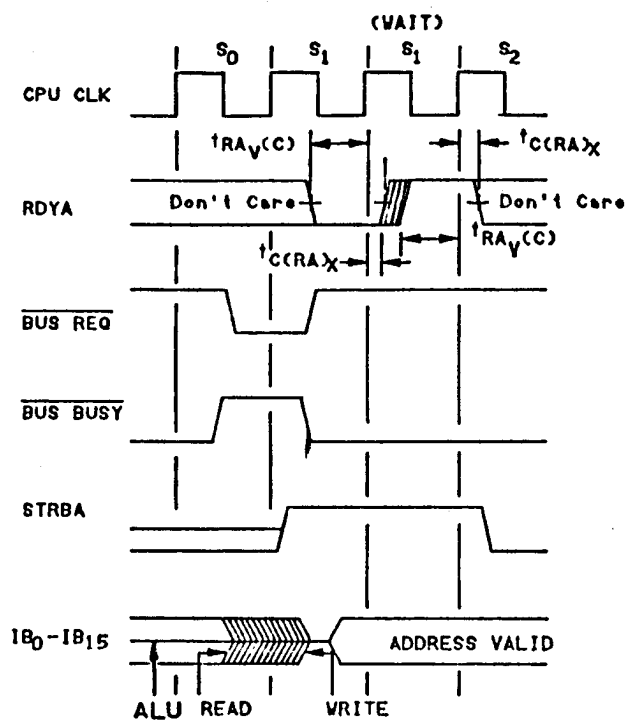

RDYD SIGNAL - READ BUS CYCLE TIMING DIAGRAM

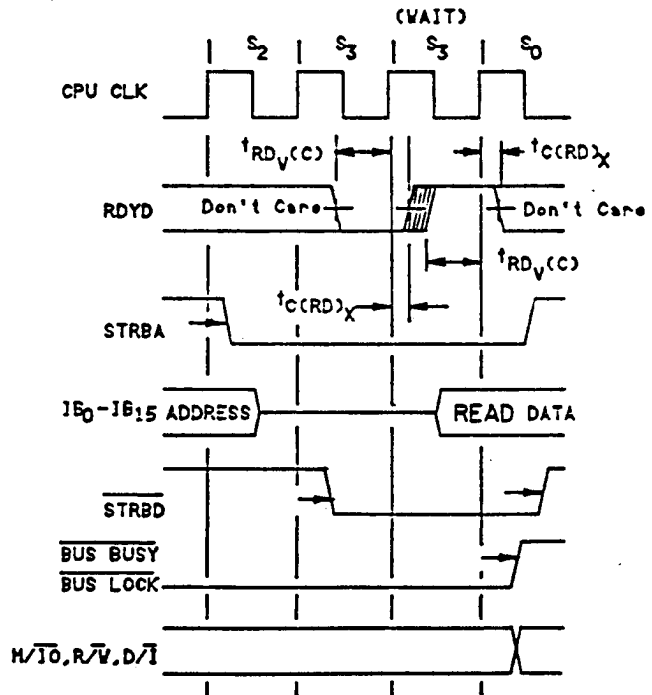

FIGURE 4. Timing waveforms - Continued.

STANDARDIZED
MILITARY DRAWING

DEFENSE ELECTRONICS SUPPLY CENTER
DAYTON, OHIO 45444

SIZE
A

84169

REVISION LEVEL
A

SHEET

18

SIGNAL REQUIREMENTS FOR ACCESSING BUS

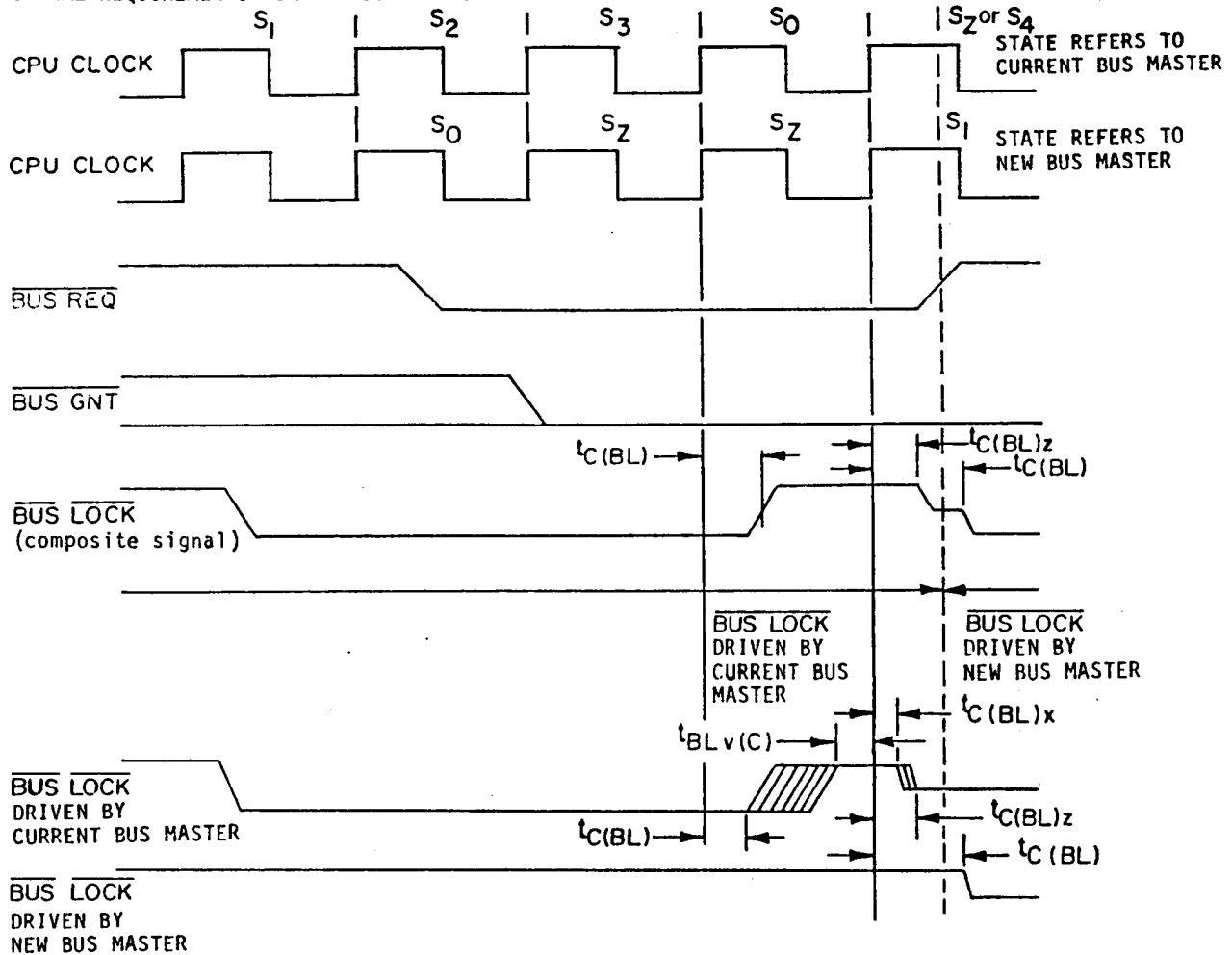

NOTES:

1. Shown is device response to external control of the BUS LOCK signal. Note that current bus master must release active drive of BUS LOCK before new bus master begins driving.
2. All device masters are F9450 or F9450 bus-compatible devices.
3. Bus masters and external arbiter are operating on the same clock.
4. State S_z is the high-impedance state in which all new bus master drivers are in a three-state condition.
5. $t_{BLv(C)}$ and $t_{C(BL)x}$ are measured as inputs to new bus master.

FIGURE 4. Timing waveforms - Continued.

STANDARDIZED MILITARY DRAWING DEFENSE ELECTRONICS SUPPLY CENTER DAYTON, OHIO 45444	SIZE A		84169
		REVISION LEVEL A	SHEET 19

SNEW DISCRETE TIMING DIAGRAM

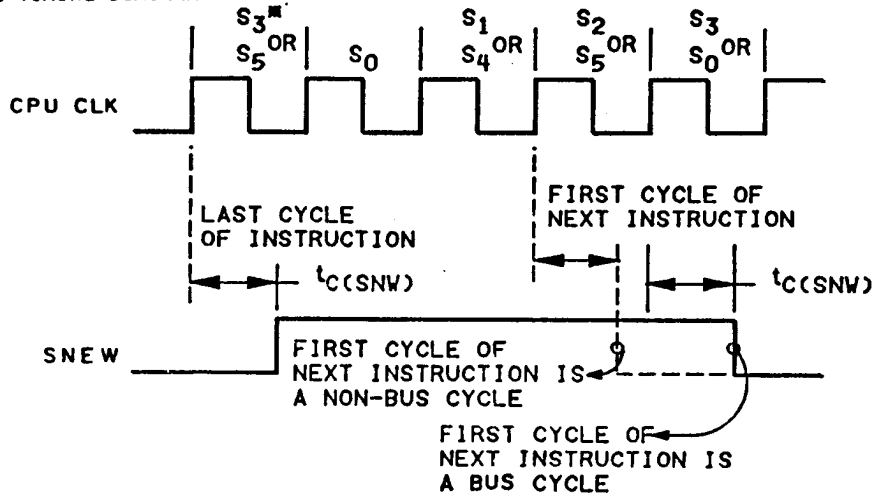

If wait states are included in the data time of the previous cycle, this will be the first S3 state.

TRIGO RST DISCRETE TIMING DIAGRAM

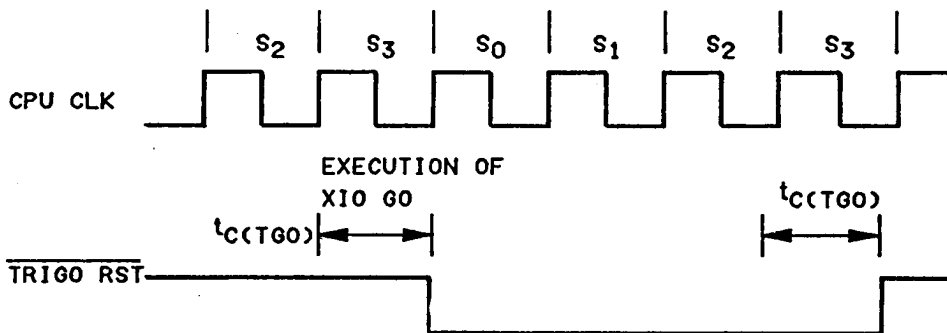

DMA EN DISCRETE TIMING DIAGRAM

B) XIO OPERATIONS

A) DURING RESET

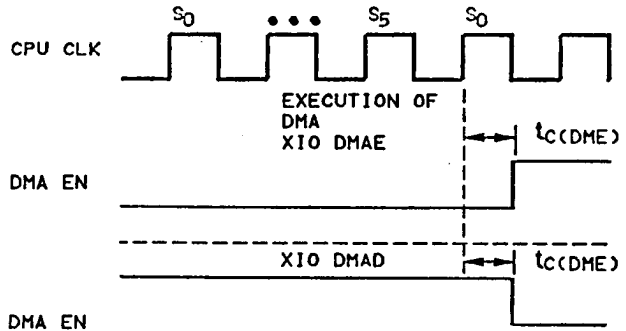
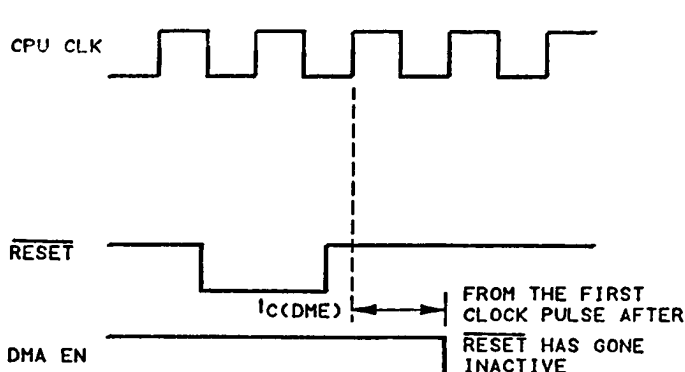

FIGURE 4. Timing waveforms - Continued.

STANDARDIZED
MILITARY DRAWING

DEFENSE ELECTRONICS SUPPLY CENTER
DAYTON, OHIO 45444

SIZE
A

84169

REVISION LEVEL
A

SHEET

20

NORMAL POWER UP DISCRETE TIMING DIAGRAM

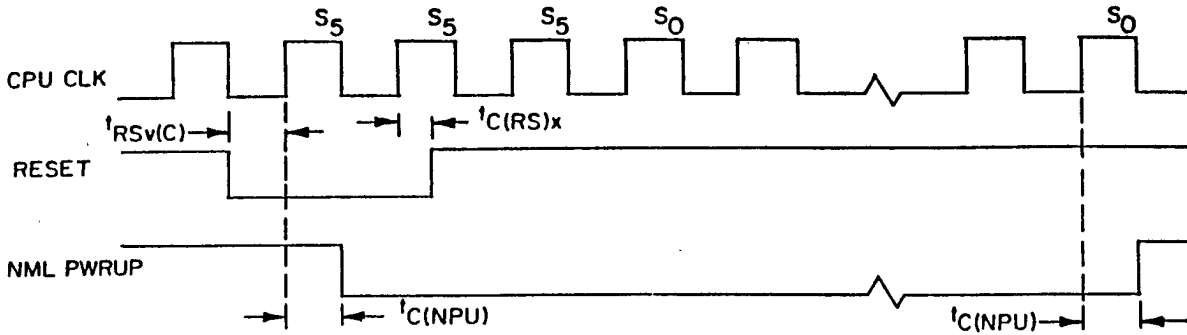

NOTE:
The CPU will remain in the S5 state as long as $\overline{\text{RESET}}$ is held low.

EXTERNAL FAULTS AND INTERRUPTS TIMING DIAGRAM

A) Edge-sensitive interrupts and faults B) Level-sensitive interrupts C) Level-sensitive faults (SYSFLT₀, SYSFLT₁) minimum pulse width

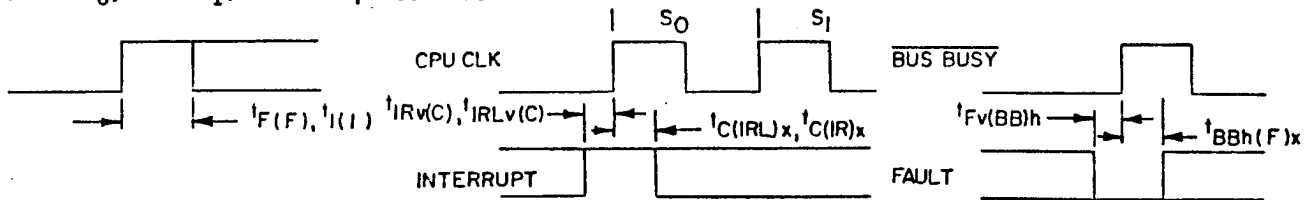

D) PAR ER

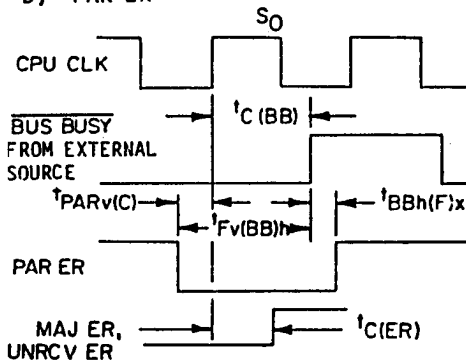

E) FAULT

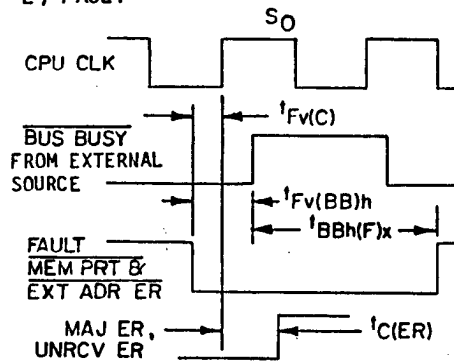

F) CON REQ

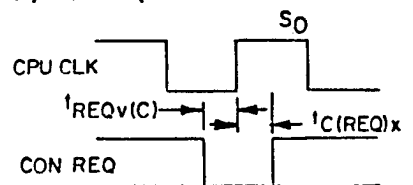

Parameter	V ₀	V _{MEA}
t _{PLZ}	V _{CC}	V _{OUT} +.1 V _I
t _{PHZ}	GND	V _{OUT} -.1 V _I

Switching Time Test Circuits

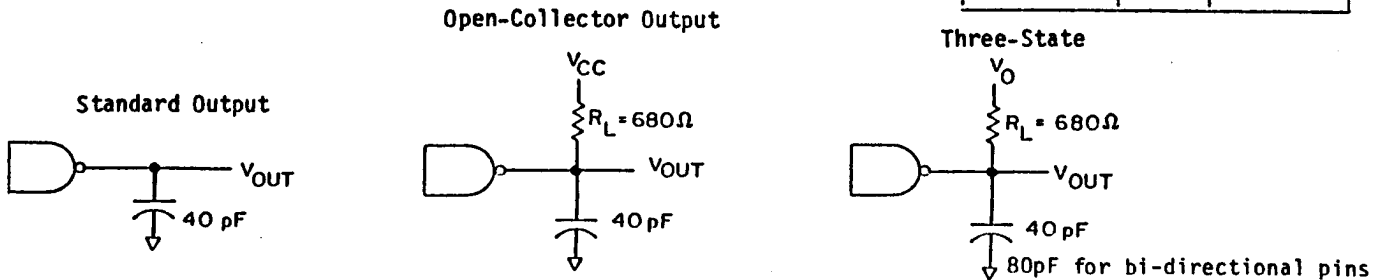

FIGURE 4. Timing waveforms - Continued.

STANDARDIZED MILITARY DRAWING DEFENSE ELECTRONICS SUPPLY CENTER DAYTON, OHIO 45444	SIZE A	84169
	REVISION LEVEL A	SHEET 21

3.7 Certification. Certification to MIL-STD-1750 verification software (VSW) test V 2.1 + 2 shall be required and the manufacturer shall be listed on the Air Force VSW compliant computer list. For device types 02, 03, and 04, MIL-STD-1750 verification software (VSW) test V 2.1 +12 is applicable.

3.8 Notification of change. Notification of change to DESC-ECS shall be required in accordance with MIL-STD-883 (see 3.1 herein).

3.9 Verification and review. DESC, DESC's agent, and the acquiring activity retain the option to review the manufacturer's facility and applicable required documentation. Offshore documentation shall be made available onshore at the option of the reviewer.

3.10 Instruction set and instruction-execution times for all device types.

3.10.1 Word key.

Instruction Set

The instruction set of the F9450 is optimized for real-time applications in accordance with the MIL-STD-1750A ISA. Table 1 shows addressing modes and related instruction word formats, Derived Address (DA), and Derived Operand (DO). Not all instructions use all the addressing modes; therefore, acceptable addressing modes should be confirmed for each instruction. Table 2 provides the instruction set with applicable addressing modes and table 3 gives the dedicated I/O addresses.

Addressing Modes

There are ten addressing modes. The smallest addressable memory word is 16 bits. Therefore, the 16-bit address field allows direct addressing of 64K words. There is no restriction on the location of double-word operands in memory.

1. **Register Direct (R)**
The instruction-specified register contains the required operand. With the exception of this mode, the DA denotes a memory address.
2. **Memory Direct (D)**
In this mode, the instruction contains the memory address of the operand.
3. **Memory Direct - Indexed (DX)**
The memory address of the required operand is specified by the sum of the contents of an index register and the instruction address field. Registers R1 through R15 may be specified for indexing.
4. **Memory Indirect (I)**
The instruction-specified memory address contains the address of the required operand.
5. **Memory Indirect with Pre-Indexing (IX)**
The sum of the contents of a specified index register and the instruction address field specify the address of a memory location containing the address of the required operand. Registers R1 through R15 may be specified for pre-indexing.

6. **Immediate Long (IM)**

One method of Immediate Long addressing allows indexing and one does not. The indexable form of immediate addressing is shown in table 3. If the specified index register, RX, is $\neq 0$, the contents of RX is added to the immediate field to form the required operand; otherwise, the immediate field contains the required operand.

7. **Immediate Short (IS)**

The required 4-bit operand is contained within the 16-bit instruction. One method of Immediate Short addressing interprets the contents of the immediate field as positive data and another method interprets the contents of the immediate field as negative data.

a. **Immediate Short Positive (ISP)**

The immediate operand is treated as a positive integer between 1 and 16.

b. **Immediate Short Negative (ISN)**

The immediate operand is treated as a negative integer between 1 and 16. Its internal form is a two's-complement, sign-extended 16-bit number.

8. **Instruction Counter Relative (ICR)**

This mode is used for 16-bit branch instructions. The contents of the instruction counter minus one (i.e., the address of the current instruction) are added to the sign-extended 8-bit displacement field of the instruction. The sum points to the memory address to which control may be transferred if a branch is executed. This mode allows addressing within a memory region of -128 to +127 words, relative to the address of the current instruction.

9. **Base Relative (B)**

The contents of an instruction-specified base register are added to the 8-bit displacement field of the 16-bit instruction. The displacement field is taken to be a positive number between 0 and 255. The sum points to the memory address of the required operand. This mode allows addressing within a memory region of 256 words, beginning at the address pointed to by the base register.

10. **Base Relative - Indexed (BX)**

The sum of the contents of a specified index register and a specified base register is the address of the required operand. Registers R1 through R15 may be specified for indexing.

STANDARDIZED MILITARY DRAWING DEFENSE ELECTRONICS SUPPLY CENTER DAYTON, OHIO 45444	SIZE A		84169
		REVISION LEVEL A	SHEET 22

3.10.2 Addressing modes and instruction formats.

Mode	Format	Derived Operand (DO)		Derived Address (DA)																	
		Single-Precision	Floating-Point and Double Precision	Single-Precision	Floating-Point and Double Precision																
1. Register Direct "R"	<table border="1"> <tr> <td>0</td><td>7</td><td>8</td><td>11</td><td>12</td><td>15</td> </tr> <tr> <td>O.C.</td><td colspan="2">RA</td><td colspan="3">RB</td> </tr> </table>	0	7	8	11	12	15	O.C.	RA		RB			(RB)	(RB, RB + 1)	RB	RB, RB + 1				
0	7	8	11	12	15																
O.C.	RA		RB																		
2. Memory Direct "D" "DX"	<table border="1"> <tr> <td>0</td><td>7</td><td>8</td><td>11</td><td>12</td><td>15</td><td>16</td><td>31</td> </tr> <tr> <td>O.C.</td><td colspan="2">RA</td><td colspan="2">RX</td><td colspan="3">A</td> </tr> </table> RX = 0 (Non-Indexed) RX ≠ 0 (Indexed)	0	7	8	11	12	15	16	31	O.C.	RA		RX		A			[A] [A + (RX)]	[A, A + 1] [A + (RX), A + 1 + (RX)]	A A + (RX)	A, A + 1 A + (RX), A + 1 + (RX)
0	7	8	11	12	15	16	31														
O.C.	RA		RX		A																
3. Memory Indirect "I" "IX"	<table border="1"> <tr> <td>0</td><td>7</td><td>8</td><td>11</td><td>12</td><td>15</td><td>16</td><td>31</td> </tr> <tr> <td>O.C.</td><td colspan="2">RA</td><td colspan="2">RX</td><td colspan="3">A</td> </tr> </table> RX = 0 (Non-Indexed) RX ≠ 0 (Indexed)	0	7	8	11	12	15	16	31	O.C.	RA		RX		A			[A] [A + (RX)]	[A , A + 1] [A + (RX) , A + (RX) + 1]	[A] [A + (RX)]	[A], [A] + 1 [A + (RX)], [A + (RX)] + 1
0	7	8	11	12	15	16	31														
O.C.	RA		RX		A																
4. Immediate Long a. Not Indexable "IM"	<table border="1"> <tr> <td>0</td><td>7</td><td>8</td><td>11</td><td>12</td><td>15</td><td>16</td><td>31</td> </tr> <tr> <td>O.C.</td><td colspan="2">RA</td><td colspan="2">OCX</td><td colspan="3">I</td> </tr> </table>	0	7	8	11	12	15	16	31	O.C.	RA		OCX		I			I			
0	7	8	11	12	15	16	31														
O.C.	RA		OCX		I																
b. Indexable "IM" "IMX"	<table border="1"> <tr> <td>C</td><td>7</td><td>8</td><td>11</td><td>12</td><td>15</td><td>16</td><td>31</td> </tr> <tr> <td>O.C.</td><td colspan="2">RA</td><td colspan="2">RX</td><td colspan="3">I</td> </tr> </table> RX = 0 (Non-Indexed) RX ≠ 0 (Indexed)	C	7	8	11	12	15	16	31	O.C.	RA		RX		I			I I + (RX)			
C	7	8	11	12	15	16	31														
O.C.	RA		RX		I																
5. Immediate Short a. Positive "ISP"	<table border="1"> <tr> <td>0</td><td>7</td><td>8</td><td>11</td><td>12</td><td>15</td> </tr> <tr> <td>O.C.</td><td colspan="2">RA</td><td colspan="3">I</td> </tr> </table>	0	7	8	11	12	15	O.C.	RA		I			+ (I + 1)							
0	7	8	11	12	15																
O.C.	RA		I																		
b. Negative "ISN"	<table border="1"> <tr> <td>0</td><td>7</td><td>8</td><td>11</td><td>12</td><td>15</td> </tr> <tr> <td>O.C.</td><td colspan="2">RA</td><td colspan="3">I</td> </tr> </table>	0	7	8	11	12	15	O.C.	RA		I			-(I + 1)							
0	7	8	11	12	15																
O.C.	RA		I																		
6. IC Relative (1) "ICR"	<table border="1"> <tr> <td>0</td><td>7</td><td>8</td><td>15</td> </tr> <tr> <td>O.C.</td><td colspan="2"></td><td>DU</td> </tr> </table>	0	7	8	15	O.C.			DU			DU + (IC - 1)									
0	7	8	15																		
O.C.			DU																		
7. Base Relative (2) a. Not Indexable (2) "B"	<table border="1"> <tr> <td>0</td><td>5</td><td>6</td><td>7</td><td>8</td><td>15</td> </tr> <tr> <td>O.C.</td><td colspan="2">BR</td><td colspan="3">DU</td> </tr> </table> BR = BR + 12	0	5	6	7	8	15	O.C.	BR		DU			[DU + (BR)]	[DU + (BR), DU + 1 + (BR)]	DU + (BR)	DU + (BR), DU + 1 + (BR)				
0	5	6	7	8	15																
O.C.	BR		DU																		
b. Indexable "B" "BX"	<table border="1"> <tr> <td>0</td><td>5</td><td>6</td><td>7</td><td>8</td><td>11</td><td>12</td><td>15</td> </tr> <tr> <td>O.C.</td><td colspan="2">BR</td><td colspan="2">OCX</td><td colspan="3">RX</td> </tr> </table> RX = 0 (Non-Indexed) RX ≠ 0 (Indexed)	0	5	6	7	8	11	12	15	O.C.	BR		OCX		RX			[BR] [BR + (RX)]	[BR], (BR) + 1 [BR + (RX), (BR) + 1 + (RX)]	(BR) (BR) + (RX)	(BR), (BR) + 1 (BR) + (RX), (BR) + 1 + (RX)
0	5	6	7	8	11	12	15														
O.C.	BR		OCX		RX																

Notes:

- 128 ≤ DU ≤ 127.
- Base registers: BR = R12, R13, R14, and R15.
- 0 ≤ DU ≤ 255.
- Extended-precision floating-point instructions require addressing of three operands located at DA, DA + 1, and DA + 2.

STANDARDIZED MILITARY DRAWING DEFENSE ELECTRONICS SUPPLY CENTER DAYTON, OHIO 45444	SIZE A	84169
	REVISION LEVEL A	SHEET 23

3.10.3 Instruction execution times.

FUNCTION	INST	MODE	Nf	No	Nc	NOTES
INTEGER ARITHMETIC/LOGIC						
Single-Precision Add	A	R	1	0	5	Nf/N6
	A	B	1	1	12	Nf/N6
	A	BX	1	1	12	Nf/N6
	A	ISP	1	0	8	Nf/N6
	A	D	2	1	13	Nf/N6
	A	DX	2	1	13	Nf/N6
	A	IM	2	0	12	Nf/N6
Double-Precision Add	DA	R	1	0	18	
	DA	D	2	2	24	
	DA	DX	2	2	24	
Increment Memory by Positive Integer	INCM	D	2	2	17	Nf/N6 Bus Lock
	INCM	DX	2	2	17	Nf/N6 Bus Lock
Single-Precision Absolute Value	ABS	R	1	0	5	Nf/N6, Pos. #
	ABS	R	1	0	10	Nf/N6, Neg. #
Double-Precision Absolute Value	DABS	R	1	0	13	Pos. #
	DABS	R	1	0	21	Neg. #
Single-Precision Subtract	S	R	1	0	5	Nf/N6
	S	B	1	1	12	Nf/N6
	S	BX	1	1	12	Nf/N6
	S	ISP	1	0	8	Nf/N6
	S	D	2	1	13	Nf/N6
	S	DX	2	1	13	Nf/N6
	S	IM	2	0	12	Nf/N6
Double-Precision Subtract	DS	R	1	0	18	
	DS	D	2	2	24	
	DS	DX	2	2	24	
Decrement Memory by Positive Integer	DECM	D	2	2	17	Nf/N6 Bus Lock
	DECM	DX	2	2	17	Nf/N6 Bus Lock

Nf: Number of Instruction Fetch Bus cycles.

No: Number of Operand Bus cycles (either memory or I/O). I/O cycles are indicated with a note in the comments column.

VIO instructions include only the execution of one operation.

Nc: Total number of clocks to execute the instruction with the given number of address and data wait states.

Nf/N6: An Instruction Fetch cycle occurs during a 5 clock machine cycle. This allows the user to discount 1 data phase wait state.

Bus Lock: The Bus Lock signal is used during the execution of this instruction to hold the bus for use during 2 consecutive machine cycles.

Bus Lock (1): This instruction activates Bus Lock and keeps it active for 2 Bus cycles with 1 intervening ALU cycle.

Bus Lock (2): This instruction activates Bus Lock and keeps it active for a total of 4 machine cycles, including:

- 1 Memory Read Bus cycle
- 1 ALU cycle
- 1 Memory Read Bus cycle
- 1 Memory Write Bus cycle

NOTE: Calculation of some instruction execution times requires the addition of more than one number, e.g. the time for an RPI I/O command in a VIO chain requires the addition of the base time for the VIO instruction, plus the incremental time for each VIO operation, plus the time for any unused bits preceding the RPI in the VIO Vector Select, plus the time for the RPI command.

STANDARDIZED MILITARY DRAWING DEFENSE ELECTRONICS SUPPLY CENTER DAYTON, OHIO 45444	SIZE A		84169
		REVISION LEVEL A	SHEET 24

FUNCTION	INST	MODE	Nf	No	Nc	NOTES
Single-Precision Negate	NEG	R	1	0	5	Nf/N6
Double-Precision Negate	DNEG	R	1	0	18	
Single-Precision Multiply	MS	R	1	0	44	
16-Bit Product	MS	ISP	1	0	47	
	MS	ISN	1	0	47	
	MS	D	2	1	52	
	MS	DX	2	1	52	
	MS	IM	2	0	51	
			0	0	(30)	+ ZERO MULTIPLICAND
Single-Precision Multiply	M	R	1	0	42	
32-Bit Product	M	B	1	1	49	
	M	BX	1	1	49	
	M	D	2	1	50	
	M	DX	2	1	50	
	M	IM	2	0	49	
			0	0	5	+ZERO MSW OF MULTIPLICAND
			0	0	(25)	+ ZERO MULTIPLICAND
Double-Precision Multiply	DM	R	1	0	130	
	DM	D	2	2	136	
	DM	DX	2	2	136	
Single-Precision Divide	DV	R	1	0	100	Nf/N6
16-Bit Dividend	DV	ISP	1	0	100	Nf/N6
	DV	ISN	1	0	100	Nf/N6
	DV	D	2	1	105	Nf/N6
	DV	DX	2	1	105	Nf/N6
	DV	IM	2	0	104	Nf/N6
			0	0	5	Add for dividend = 8000(H)
			0	0	6	Add for negative dividend
			0	0	3	Add for negative divisor
			0	0	3	Add for remainder correction
Single-Precision Divide	D	R	1	0	101	Nf/N6
32-Bit Dividend	D	B	1	1	105	Nf/N6
	D	BX	1	1	105	Nf/N6
	D	D	2	1	106	Nf/N6
	D	DX	2	1	106	Nf/N6
	D	IM	2	0	105	Nf/N6
			0	0	6	Add for RA ≥ divisor
Divisor			0	0	9	Add for negative dividend
			0	0	5	Add for negative divisor
			0	0	3	Add for remainder correction
Double-Precision Divide	DD	R	1	0	241	
	DD	D	2	2	247	
	DD	DX	2	2	247	
			0	0	6	Add for negative dividend
			0	0	6	Add for negative divisor
			0	0	7	Add for negative result
			0	0	5	Add for MSW of dividend = 8000(H)
			0	0	5	Add for dividend = 8000 0000(H)
			0	0	5	Add above + LSW of dividend = -1
Single-Precision Compare	C	R	1	0	8	Nf/N6
	C	B	1	1	15	Nf/N6
	C	BX	1	1	15	Nf/N6
	C	ISP	1	0	11	Nf/N6
	C	ISN	1	0	11	Nf/N6
	C	D	2	1	16	Nf/N6
	C	DX	2	1	16	Nf/N6

**STANDARDIZED
MILITARY DRAWING**

DEFENSE ELECTRONICS SUPPLY CENTER
DAYTON, OHIO 45444

SIZE
A

84169

REVISION LEVEL
A

SHEET
25

FUNCTION	INST	MODE	Nf	No	Nc	NOTES	
Compare Between Limits	C	IM	2	0	15	Nf/N6	
	CBL	D	2	2	30	Nf/N6 (RA<DO1)	
			2	2	43	Nf/N6 (DO1≤RA≤DO2)	
			2	2	40	Nf/N6 (RA>DO2)	
	Double-Precision Compare	CBL	DX	2	2	30	Nf/N6 (RA<DO1)
2				2	43	Nf/N6 (DO1≤RA≤DO2)	
				2	2	40	Nf/N6 (RA>DO2)
DC		R	1	0	21		
		D	2	2	27		
	DX	2	2	27			
Inclusive-OR	OR	R	1	0	4		
			1	1	11		
	OR	BX	1	1	11		
			2	1	12		
	OR	DX	2	1	12		
			2	0	11		
			1	0	4		
AND	AND	R	1	0	4		
			1	1	11		
	AND	BX	1	1	11		
			2	1	12		
	AND	DX	2	1	12		
			2	0	11		
			1	0	4		
Exclusive-OR	XOR	R	1	0	4		
			2	1	12		
	XOR	DX	2	1	12		
			2	0	11		
	XOR	IM	2	0	11		
			1	0	9		
			2	1	17		
NAND	NAND	D	2	1	17		
			2	1	17		
	NAND	IM	2	0	16		
			2	0	16		
FLOATING POINT Floating-Point Add	FA	R	1	0	91	2/	
			1	0	70	3/	
			1	2	96	2/	
	FA	BX	1	2	75	3/	
			1	2	96	2/	
	FA	D	1	2	75	3/	
			2	2	97	2/	
			2	2	76	3/	
	FA	DX	2	2	97	2/	
			2	2	76	3/	
	FA	ALL	0	0	(15)		
			0	0	(67)	2/	
			0	0	(46)	3/	
			0	0	14		
			0	0	8		
0			0	6			
0			0	6			
0			0	6			
0			0	5			
0			0	13			
0	0	5					
0	0	10					

No shifts in exponent adjust and in normalization

+ RA=0
+ DO=0

+ ADDITION OVERFLOW
+ SCALE RA INCREMENTAL
+ SCALE DO INCREMENTAL
+ NORMALIZE INCREMENTAL
UNNORMALIZED MANTISSA = 0
RESULT=0

STANDARDIZED MILITARY DRAWING DEFENSE ELECTRONICS SUPPLY CENTER DAYTON, OHIO 45444	SIZE A		84169
		REVISION LEVEL A	SHEET 26

FUNCTION	INST	MODE	Nf	No	Nc	NOTES
Extended-Precision Floating-Point Add	EFA	R	1	0	106	2/
			1	0	85	3/
	EFA	D	2	3	113	2/
			2	3	92	3/
	EFA	DX	2	3	113	2/
			2	3	92	3/
	EFA	ALL	0	0	(15)	+ RA=0
			0	0	(76)	+ DO=0
			0	0	(55)	2/
			0	0	17	3/
			0	0	8	+ ADDITION OVERFLOW
			0	0	9	+ SCALE RA
			0	0	6	INCREMENTAL
			0	0	9	+ SCALE DO
			0	0	8	INCREMENTAL
			0	0	16	+ NORMALIZE
			0	0	2	INCREMENTAL
			0	0	7	MSH OF MANTISSA = 0
			0	0	20	UNNORMALIZED MANTISSA = 0
	Floating-Point Absolute Value Floating-Point Subtract	FABS	R	1	0	16
FABS		R	1	0	71	Pos. #
FS		R	1	0	91	Neg. #
			1	0	70	2/
FS		B	1	2	96	3/
			1	2	75	2/
FS		BX	1	2	96	3/
			1	2	75	2/
FS		D	2	2	97	3/
			2	2	76	2/
FS		DX	2	2	97	3/
			2	2	76	2/
FS		ALL	0	0	(15)	3/
			0	0	(67)	+ RA=0
			0	0	(46)	+ DO=0
			0	0	14	2/
			0	0	17	3/
			0	0	8	+ ADDITION OVERFLOW
			0	0	6	+ SCALE RA
			0	0	6	INCREMENTAL
		0	0	6	+ SCALE DO	
		0	0	5	INCREMENTAL	
		0	0	13	+ NORMALIZE	
		0	0	5	INCREMENTAL	
		0	0	10	UNNORMALIZED MANTISSA = 0	
Extended-Precision Floating-Point Subtract	EFS	R	1	0	106	2/
			1	0	85	3/
	EFS	D	2	3	113	2/
			2	3	92	3/
	EFS	DX	2	3	113	2/
			2	3	92	3/

STANDARDIZED MILITARY DRAWING DEFENSE ELECTRONICS SUPPLY CENTER DAYTON, OHIO 45444	SIZE A		84169
		REVISION LEVEL A	SHEET 27

DESC FORM 193A
SEP 87

* U. S. GOVERNMENT PRINTING OFFICE: 1988-549-904

FUNCTION	INST	MODE	Nf	No	Nc	NOTES
	EFS	ALL	0	0	(15)	+ RA=0 + DO=0 2/ 3/ + ADDITION OVERFLOW + SCALE RA INCREMENTAL + SCALE DO INCREMENTAL + NORMALIZE INCREMENTAL MSH OF MANTISSA = 0 UNNORMALIZED MANTISSA = 0 RESULT=0 POS # NEG #
			0	0	(76)	
			0	0	5	
			0	0	17	
			0	0	8	
			0	0	9	
			0	0	6	
			0	0	9	
			0	0	8	
			0	0	16	
			0	0	2	
			0	0	7	
			0	0	20	
			0	0	61	
			0	0	65	
Floating-Point Negate	FNEG	R	1	0	61	
Floating-Point Multiply	FM	R	1	0	120	
			1	2	125	
			1	2	125	
			2	2	126	
			2	2	126	
			0	0	18	
			0	0	6	
Extended-Precision Floating-Point Multiply	EFM	R	1	0	243	+ NORMALIZE + 8000 00XX* 8000 00XX
			2	3	250	
			2	3	250	
			0	0	24	
Floating-Point Divide	FD	R	1	0	222	+ NORMALIZE + 8000 00XX 0000*8000 00XX 0000
			1	2	227	
			1	2	227	
			2	2	228	
			2	2	228	
			0	0	18	
			0	0	14	
			0	0	9	
			0	0	(181)	
			0	0	(195)	
			0	0	6	
			0	0	6	
Extended-Precision Floating-Point Divide	EFD	R	1	0	462	+ NORMALIZE + MAN(RA) > MAN(DO) + MAN(RA) = MAN(DO) + DIVISOR=0 + DIVIDEND=0 + CORRECTION REQUIRED
			2	3	469	
			2	3	469	
			0	0	24	
			0	0	17	
			0	0	12	
			0	0	(412)	
Floating-Point Compare	FC	R	1	0	52	+ NORMALIZE + MAN(RA) > MAN(DO) + MAN(RA) = MAN(DO) + DIVISOR=0 + DIVIDEND=0 + CORRECTION REQUIRED Nf/N6; RA<DO; RA>DO, A1<>0 Nf/N6; RA<DO; RA>DO, A1<>0 Nf/N6; RA<DO; RA>DO, A1<>0 Nf/N6; RA<DO; RA>DO, A1<>0
			1	2	57	
			1	2	57	
			2	2	58	
			0	0	3	
			0	0	(435)	
			0	0	3	
			0	0	3	

STANDARDIZED MILITARY DRAWING DEFENSE ELECTRONICS SUPPLY CENTER DAYTON, OHIO 45444	SIZE A		84169
		REVISION LEVEL A	SHEET 28

DESC FORM 193A
SEP 87

* U. S. GOVERNMENT PRINTING OFFICE: 1988-549-904

FUNCTION	INST	MODE	Nf	No	Nc	NOTES						
Extended-Precision Floating-Point Compare	FC	DX	2	2	58	Nf/N6; RA<DO; RA>DO, A1<>0						
			0	0	(15)	+ RA=0						
			0	0	(28)	+ DO=0						
			0	0	14	+ ADDITION OVERFLOW						
			0	0	8	+ SCALE RA						
			0	0	6	INCREMENTAL						
			0	0	3	+ SCALE DO						
			0	0	6	INCREMENTAL						
			0	0	10	+ RA = DO; RA>DO, A1=0, A2>0						
			0	0	13	+ RA>DO, A1=0, A2<0						
			EFC	R	1	0	55	Nf/N6; RA<DO; RA>DO, A1<>0				
			EFC	D	2	3	68	Nf/N6; RA<DO; RA>DO, A1<>0				
			EFC	DX	2	3	68	Nf/N6; RA<DO; RA>DO, A1<>0				
			EFC	ALL	0	0	(15)	+ RA=0				
			Convert Floating-Point to 16-Bit Integer	FIX	R	0	0	(31)	+ DO=0			
0	0	9				+ ADDITION OVERFLOW						
0	0	8				+ SCALE RA						
0	0	9				INCREMENTAL						
0	0	3				+ SCALE DO						
0	0	9				INCREMENTAL						
0	0	15				+ RA = DO						
0	0	8				+ RA>DO, A1=0, A2>0						
0	0	13				+ RA>DO, A1=0, A2<0						
0	0	15				+ RA>DO, A1=0, A2=0, Q1>0						
0	0	18				+ RA>DO, A1=0, A2=0, Q1<0						
1	0	28				Nf/N6, 0<EXP(RB)<15						
0	0	3				INCREMENTAL (14-EXP(RB) TIMES)						
1	0	10				Nf/N6, RB=0						
Convert 16-Bit Integer to Floating Point	FLT	R				1	0	25	Nf/N6, EXP(RB)=15			
			0	0	8	+ RB<0, RB+1=0						
			0	0	10	+ RB<0, RB+1<>0						
			1	0	13	Nf/N6, EXP(RB)<0						
			1	0	26	Nf/N6, EXP(RB)>15						
			1	0	16	Nf/N6						
			1	0	8	Nf/N6, DO=0						
			0	0	5	+ NORMALIZATION						
			0	0	13	INCREMENTAL						
			Convert Extended-Precision Floating-Point to 32-Bit Integer	EFIX	R	1	0	44	0<EXP(DO)<31			
						0	0	6	INCREMENTAL (30-EXP(DO) TIMES)			
						1	0	21	RB=0			
						1	0	36	EXP(DO)=31			
						0	0	8	+ RB<0, RB+2=0			
						0	0	15	+ RB<0, RB+2<>0			
1	0	24				EXP(DO)<0						
1	0	39				EXP(DO)>31						
Convert 32-Bit Integer to Extended-Precision Floating Point	EFLT	R				1	0	31	Nf/N6, RA<>0			
						0	0	8	+ NORMALIZATION			
						0	0	16	+ NORMALIZATION, INCREMENTAL			
						0	0	2	+ RA=0, RA<>0			
						1	0	22	Nf/N6, RA=0, RA+1=0			
						Set Bit	BIT OPERATIONS					
							SB	R	1	0	7	
			SB	D	2		2	16	Bus Lock			
			SB	DX	2		2	16	Bus Lock			
			SB	I	2		3	20	Bus Lock			
			SB	IX	2	3	20	Bus Lock				

STANDARDIZED MILITARY DRAWING DEFENSE ELECTRONICS SUPPLY CENTER DAYTON, OHIO 45444	SIZE A	84169
	REVISION LEVEL A	SHEET 29

DESC FORM 193A
SEP 87

FUNCTION	INST	MODE	Nf	No	Nc	NOTES
Reset Bit	RB	R	2	0	7	
	RB	D	2	2	16	Bus Lock
	RB	DX	2	2	16	Bus Lock
	RB	I	2	3	20	Bus Lock
	RB	IX	2	3	20	Bus Lock
Test Bit	TB	R	2	0	7	
	TB	D	2	1	15	
	TB	DX	2	1	15	
	TB	I	2	2	19	
	TB	IX	2	2	19	
Test and Set Bit	TSB	D	2	3	23	Bus Lock(2)
	TSB	DX	2	3	23	Bus Lock(2)
Set Variable Bit in Register	SVBR	R	1	0	7	
Reset Variable Bit in Register	RVBR	R	1	0	7	
Test Variable Bit in Register	TVBR	R	1	0	7	
SHIFT						
Shift Left Logical	SLL	R	1	0	7	One Shift
			0	0	3	Incremental
Shift Right Logical	SRL	R	1	0	7	One Shift
			0	0	3	Incremental
Shift Right Arithmetic	SRA	R	1	0	7	One Shift
			0	0	3	Incremental
Shift Left Cyclic	SLC	R	1	0	7	One Shift
			0	0	3	Incremental
Double Shift Left Logical	DSLL	R	1	0	16	One Shift
			0	0	6	Incremental
Double Shift Right Logical	DSRL	R	1	0	16	One Shift
			0	0	6	Incremental
Double Shift Right Arithmetic	DSRA	R	1	0	16	One Shift
			0	0	6	Incremental
Double Shift Left Cyclic	DSLCL	R	1	0	19	One Shift
			0	0	9	Incremental
Shift Logical, Count in Register	SLR	R	1	0	8	Nf/N6, no shift
			1	0	21	Nf/N6, right
			0	0	3	Incremental
Shift Arithmetic, Count in Register	SAR	R	1	0	38	Nf/N6, left
			0	0	5	Incremental
			1	0	8	Nf/N6, no shift
Shift Cyclic, Count in Register	SCR	R	1	0	21	Nf/N6, right
			0	0	3	Incremental
			1	0	24	Nf/N6, left
Double Shift Logical, Count in Register	DSLRL	R	1	0	3	Incremental
			1	0	11	Nf/N6, no shift
			1	0	30	Nf/N6, right
Double Shift Arithmetic, Count in Register	DSLRL	R	0	0	6	Incremental
			1	0	44	Nf/N6, left
			0	0	8	Incremental
Double Shift Arithmetic, Count in Register	DSAR	R	1	0	11	Nf/N6, no shift
			1	0	30	Nf/N6, right
			0	0	6	Incremental

**STANDARDIZED
MILITARY DRAWING**

DEFENSE ELECTRONICS SUPPLY CENTER
DAYTON, OHIO 45444

SIZE
A

84169

REVISION LEVEL
A

SHEET
30

FUNCTION	INST	MODE	Nf	No	Nc	NOTES
Double Shift Cyclic, Count in Register	DSAR	R	1	0	35	Nf/N6, left Incremental Nf/N6, no shift Nf/N6, right Incremental Nf/N6, left Incremental
			0	0	8	
	DSCR	R	1	0	11	
			1	0	33	
			0	0	9	
	DSCR	R	1	0	33	
			0	0	9	
LOAD/STORE/EXCHANGE						
Single-Precision Load	L	R	1	0	4	
	L	B	1	1	11	
	L	BX	1	1	11	
	L	ISP	1	0	7	
	L	ISN	1	0	7	
	L	D	2	1	12	
	L	DX	2	1	12	
	L	IM	2	0	11	
	L	IMX	2	0	14	
	L	I	2	2	16	
Double-Precision Load	L	IX	2	2	16	
	DL	R	1	0	16	
	DL	B	1	2	21	
	DL	BX	1	2	21	
	DL	D	2	2	22	
	DL	DX	2	2	22	
	DL	I	2	3	26	
Extended-Precision Floating-Point Load Load from Upper Byte	DL	IX	2	3	26	
	EFL	D	2	3	26	
	EFL	DX	2	3	26	
Load from Lower Byte	LUB	D	2	1	15	
	LUB	DX	2	1	15	
	LUB	I	2	2	19	
	LUB	IX	2	2	19	
Single-Precision Store	LLB	D	2	1	12	
	LLB	DX	2	1	12	
	LLB	I	2	2	16	
	LLB	IX	2	2	16	
Store a Non-Negative Constant	ST	B	1	1	11	
	ST	BX	1	1	11	
	ST	D	2	1	12	
	ST	DX	2	1	12	
	ST	I	2	2	16	
Double-Precision Store	ST	IX	2	2	16	
	STC	D	2	1	12	
	STC	DX	2	1	12	
	STC	I	2	2	16	
Store Register through Mask	STC	IX	2	2	16	
	DST	B	1	2	15	
	DST	BX	1	2	15	
	DST	D	2	2	16	
	DST	DX	2	2	16	
Extended-Precision Floating-Point Store Store into Upper Byte	DST	I	2	3	20	
	DST	IX	2	3	20	
	SRM	D	2	2	25	Bus Lock(1)
	SRM	DX	2	2	25	Bus Lock(1)
	EFST	D	2	3	20	
	EFST	DX	2	3	20	
	STUB	D	2	2	16	Bus Lock

STANDARDIZED MILITARY DRAWING DEFENSE ELECTRONICS SUPPLY CENTER DAYTON, OHIO 45444	SIZE A	84169
	REVISION LEVEL A	SHEET 31

DESC FORM 193A
SEP 87

* U. S. GOVERNMENT PRINTING OFFICE: 1968-549-904

FUNCTION	INST	MODE	Nf	No	Nc	NOTES	
Store into Lower Byte	STUB	DX	2	2	16	Bus Lock	
	STUB	I	2	3	20	Bus Lock	
	STUB	IX	2	3	20	Bus Lock	
	STLB	D	2	2	16	Bus Lock	
	STLB	DX	2	2	16	Bus Lock	
	STLB	I	2	3	20	Bus Lock	
Exchange Bytes in Register	STLB	IX	2	3	20	Bus Lock	
Exchange Words in Registers	XBR	S	1	0	7		
	XWR	R	1	0	10		
MULTIPLE LOAD/STORE							
Push Multiple Registers onto the Stack	PSHM	S	1	1	16	One operation	
			0	1	12	Incremental	
Pop Multiple Registers off the Stack	POPM	S	1	1	20	Nf/N6	
			0	1	16	Incremental	
Load Multiple Registers	LM	D	2	1	16		
			0	1	8	Incremental	
	LM	DX	2	1	16		
			0	1	8	Incremental	
Store Multiple Registers	STM	D	2	1	17		
			0	1	9	Incremental	
	STM	DX	2	1	17		
			0	1	9	Incremental	
Move Multiple Words, Memory-to-Memory	MOV	S	1	0	9	Incremental	
			1	2	37	no move	
			0	2	13	one move	
PROGRAM CONTROL							
Jump on Condition	JC	D	2	0	9	Nf/N6, No Jump	
	JC	D	3	0	17	Nf/N6, Jump	
	JC	DX	2	0	9	Nf/N6, No Jump	
	JC	DX	3	0	17	Nf/N6, Jump	
	JC	I	2	1	13	Nf/N6, No Jump	
	JC	I	3	1	21	Nf/N6, Jump	
	JC	IX	2	1	13	Nf/N6, No Jump	
	JC	IX	3	1	21	Nf/N6, Jump	
	Jump to Subroutine	JS	D	3	0	12	
				3	0	12	
Subtract One and Jump	SOJ	D	2	0	13	No Jump	
			3	0	17	Jump	
			2	0	13	No Jump	
			3	0	17	Jump	
Branch Unconditionally	BR	ICR	2	0	14		
			1	0	4	No Branch	
Branch if Equal to (Zero)	BEZ	ICR	3	0	15	Branch	
			1	0	4	No Branch	
Branch if Less Than (Zero)	BLT	ICR	1	0	4	No Branch	
			3	0	15	Branch	
Branch if Less Than or Equal to (Zero)	BLE	ICR	1	0	4	No Branch	
			3	0	15	Branch	
Branch if Greater Than (Zero)	BGT	ICR	1	0	4	No Branch	
			3	0	15	Branch	
Branch if Not Equal to (Zero)	BNZ	ICR	1	0	4	No Branch	
			3	0	15	Branch	
Branch if Greater Than or Equal to (Zero)	BGE	ICR	1	0	4	No Branch	
			3	0	15	Branch	
Branch to Executive	BEX	S	2	8	92	No MMU	
			2	8	87	MMU	

STANDARDIZED MILITARY DRAWING	SIZE A		84169
	DEFENSE ELECTRONICS SUPPLY CENTER DAYTON, OHIO 45444	REVISION LEVEL A	SHEET 32

DESC FORM 193A
SEP 87

★ U. S. GOVERNMENT PRINTING OFFICE: 1988-549-904

FUNCTION	INST	MODE	Nf	No	Nc	NOTES	
Load Status 1/	LST	D	3	3	42	MMU Attached	
			3	3	47	No MMU Attached	
	LST	DX	3	3	42	MMU Attached	
			3	3	47	No MMU Attached	
	LST	I	3	4	46	MMU Attached	
			3	4	51	No MMU Attached	
	LST	IX	3	4	46	MMU Attached	
			3	4	51	No MMU Attached	
	Stack IC and Jump to Subroutine	SJS	D	3	1	22	
	Unstack IC and Return from Subroutine	SJS	DX	3	1	22	
No-Operation	URS	S	3	1	15		
Breakpoint	NOP	S	1	0	9		
Built-In-Function (to Utilize External Co-Processors)	BPT	S	1	1	23	No Console (I/O)	
	BIF	D	3	2	34	(I/O)	
	BIF	DX	3	2	34	(I/O)	
	BIF	I	3	3	38	(2 I/O)	
	BIF	IX	3	3	38	(2 I/O)	
PROGRAMMED INPUT/OUTPUT							
Execute Input/Output 1/	XIO	IM	2	0	27	Overhead - PI	
	XIO	IMX	2	0	30	Overhead - PI	
	XIO	IM	2	0	21	Overhead - PO	
	XIO	IMX	2	0	24	Overhead - PO	
Vectored Input/Output 1/	VIO	D	2	2	35	Overhead	
	VIO	DX	2	2	38	Overhead	
	VIO		0	1	33	PI Case - Incremental	
	VIO		0	1	30	PO Case - Incremental	
	VIO		0	0	18	Incremental - Unused Bits	
Programmed Input	PI		0	1	4	(I/O in)	
Programmed Output	PO		0	1	5	(I/O out)	
TIMER CONTROL							
Timer A Start	TAS		0	1	5	(I/O out)	
Timer A Halt	TAH		0	1	5	(I/O out)	
Output Timer A	OTA		0	1	7	(I/O out)	
Input Timer A	ITA		0	1	7	(I/O in)	
Timer B Start	TBS		0	1	5	(I/O out)	
Timer B Halt	TBH		0	1	5	(I/O out)	
Output Timer B	OTB		0	1	7	(I/O out)	
Input Timer B	ITB		0	1	7	(I/O in)	
INTERRUPT/DMA/FAULT CONTROL							
Set Interrupt Mask	SMK		0	1	4	(I/O out)	
Clear Interrupt Request	CLIR		0	1	7	(I/O out)	
Enable Interrupts	ENBL		0	1	5	(I/O out)	
Disable Interrupts	DSBL		0	1	5	(I/O out)	
Reset Pending Interrupt	RPI		0	1	18	(I/O out)	
Set Pending Interrupt	SPI		0	1	4	(I/O out)	
Read Interrupt Mask	RMK		0	1	4	(I/O in)	
Read Pending Interrupt Register	PIR		0	1	3	(I/O in)	
Read and Clear Fault Register	RCFR		0	1	7	(I/O in)	
Enable DMA	DMAE		0	1	5	(I/O out)	
Disable DMA	DMAD		0	1	5	(I/O out)	

STANDARDIZED MILITARY DRAWING DEFENSE ELECTRONICS SUPPLY CENTER DAYTON, OHIO 45444	SIZE A		84169
		REVISION LEVEL A	SHEET 33

FUNCTION	INST	MODE	Nf	No	Nc	NOTES	
MMU CONTROL							
Write Instruction Page Register	WIPR		0	1	5	(I/O out)	
Write Operand Page Register	WOPR		0	1	5	(I/O out)	
Read Instruction Page Register	RIPR		0	1	4	(I/O in)	
Read Operand Page Register	ROPR		0	1	4	(I/O in)	
BPU CONTROL							
Load Memory Protect RAM	LMP		0	1	5	(I/O out)	
Read Memory Protect RAM	RMP		0	1	4	(I/O in)	
Memory Protect Enable	MPEN		0	1	5	(I/O out)	
MISC							
Write Status Word	WSW		0	1	12	(I/O out) MMU	
	WSW		0	1	17	(I/O out) no MMU	
Read Status Word	RSW		0	1	4	(I/O in)	
Reset NML PWRUP Discrete	RNS		0	1	5	(I/O out)	
Pulse the TRIGO RST signal	GO		1	1	5	(I/O out)	
Console Operations							
Disable	74		0	0	19	Repeat Till Interrupt or CONREQ	
Examine Register	60		0	2	20		
Deposit Register	61		0	2	20		
Examine & Clear Fault Register	62		0	2	20		
Deposit Status Word	63		0	2	22		
Examine Memory	66		0	4	28		
Deposit Memory	67		0	3	21		
Examine Next Memory	6A		0	3	27		
Deposit Next Memory	6B		0	3	24		
Continue	75		2	1	24		
Examine XIO	6C		0	4	31		
Deposit XIO	6D		0	3	24		
Examine Next XIO	6E		0	3	27		
Deposit Next XIO	6F		0	3	27		
Interrupt Response							
Interrupt Acknowledge			2	9	96		No MMU
			2	9	91	MMU	

- 1/ Privileged instruction.
2/ Device type 01 only.
3/ Device types 02, 03, and 04 only.

STANDARDIZED MILITARY DRAWING DEFENSE ELECTRONICS SUPPLY CENTER DAYTON, OHIO 45444	SIZE A		84169
		REVISION LEVEL A	SHEET 34

3.10.4 MIL-STD-1750 defined I/O command.

Mnemonic	Function	I/O Command Field (Hex)		
Timer Control				
TAS	Timer A Start	4008	} The F9450 implements these I/O commands on chip.	
TAH	Time A Halt	4009		
OTA	Output Timer A	400A		
ITA	Input Timer A	C00A		
TBS	Timer B Start	400C		
TBH	Timer B Halt	400D		
OTB	Output Timer B	400E		
ITB	Input Timer B	C00E		
Interrupt/DMA/Fault Control				
SMK	Set Interrupt Mask	2000		
CLIR	Clear Interrupt Request	2001		
ENBL	Enable Interrupts	2002		
DSBL	Disable Interrupts	2003		
RPI	Reset Pending Interrupt	2004		
SPI	Set Pending Interrupt Register	2005		
RMK	Read Interrupt Mask	A000		
RPIR	Read Pending Interrupt Register	A004		
RCFR	Read and Clear Fault Register	A00F		
DMAE	DMA Enable	4006		
DMAD	DMA Disable	4007		
MISC				
WSW	Write Status Word	200E	} These commands are implemented within the F9451 and F9452. The F9450 performs no special operation during the execution of these I/O commands. The F9450 treats these as any external I/O.	
RSW	Read Status Word	A00E		
RNS	Reset Normal Power-Up Discrete	200A		
GO	Pulse TRIGO RST Output	400B		
MMU Control				
WIPR	Write Instruction Page Register	51XY		
WOPR	Write Operand Page Register	52XY		
RIPR	Read Instruction Page Register	D1XY		
ROPR	Read Operand Page Register	D2XY		
BPU Control				
LMP	Load Memory Protect RAM	50XX		
RMP	Read Memory Protect RAM	D0XX		
MPEN	Memory Protect Enable	4003		

STANDARDIZED MILITARY DRAWING DEFENSE ELECTRONICS SUPPLY CENTER DAYTON, OHIO 45444	SIZE A	84169
	REVISION LEVEL A	SHEET 35

DESC FORM 193A
SEP 87

★ U. S. GOVERNMENT PRINTING OFFICE: 1988-549-904

Mnemonic	Function	I/O Command Field (Hex)
Miscellaneous		
PO	Programmed Output	0YXX
PI	Programmed Input	8YXX
OD	Output Discretes	2008
CO	Console Output	4000
CLC	Clear Console	4001
ESUR	Enable Start Up ROM	4004
DSUR	Disable Start Up ROM	4005
RIC1	Read I/O Interrupt Code, Level 1	A001
RIC2	Read I/O Interrupt Code, Level 2	A002
RDOR	Read Discrete Output Register	A008
RDI	Read Discrete Input	A009
TPIO	Test Programmed Output	A00B
RMFS	Read Memory Fault Status	A00D
CI	Console Input	C000
RCS	Read Console Status	C001

The F9450 is totally transparent to these codes. No special operation results in the F9450 from the execution of these I/O commands. The F9450 treats these operations as any external I/O. Please refer to XIO and VIO instructions for execution times.

3.10.5 F9450 dedicated I/O addresses.

I/O Address/Command	Input/Output	Function
8400	Input	Read console command
8401	Input	Read console data
0400	Output	Write result into console
8410	Input	Read system configuration (see the "System Configuration Register (SCR)" section).
0800, 0900, 0A00, 0B00	Output	Write derived address to coprocessor no. 1, 2, 3, or 4, respectively (used to implement the Built-In Function).
0801, 0901, 0A01, 0B01	Output	Write op-code into coprocessor no. 1, 2, 3, or 4, respectively.
1000	Output	Indicate an interrupt acknowledge cycle. Used by external devices to reset their level-generated interrupts.
1F00-1F34	Output	If these I/O addresses are used within the system, they should be protected during F9450 self-test.

**STANDARDIZED
MILITARY DRAWING**
DEFENSE ELECTRONICS SUPPLY CENTER
DAYTON, OHIO 45444

SIZE
A

84169

REVISION LEVEL
A

SHEET

36

DESC FORM 193A
SEP 87

★ U. S. GOVERNMENT PRINTING OFFICE: 1988-549-904

3.10.6 Self-test and initialization sequence.

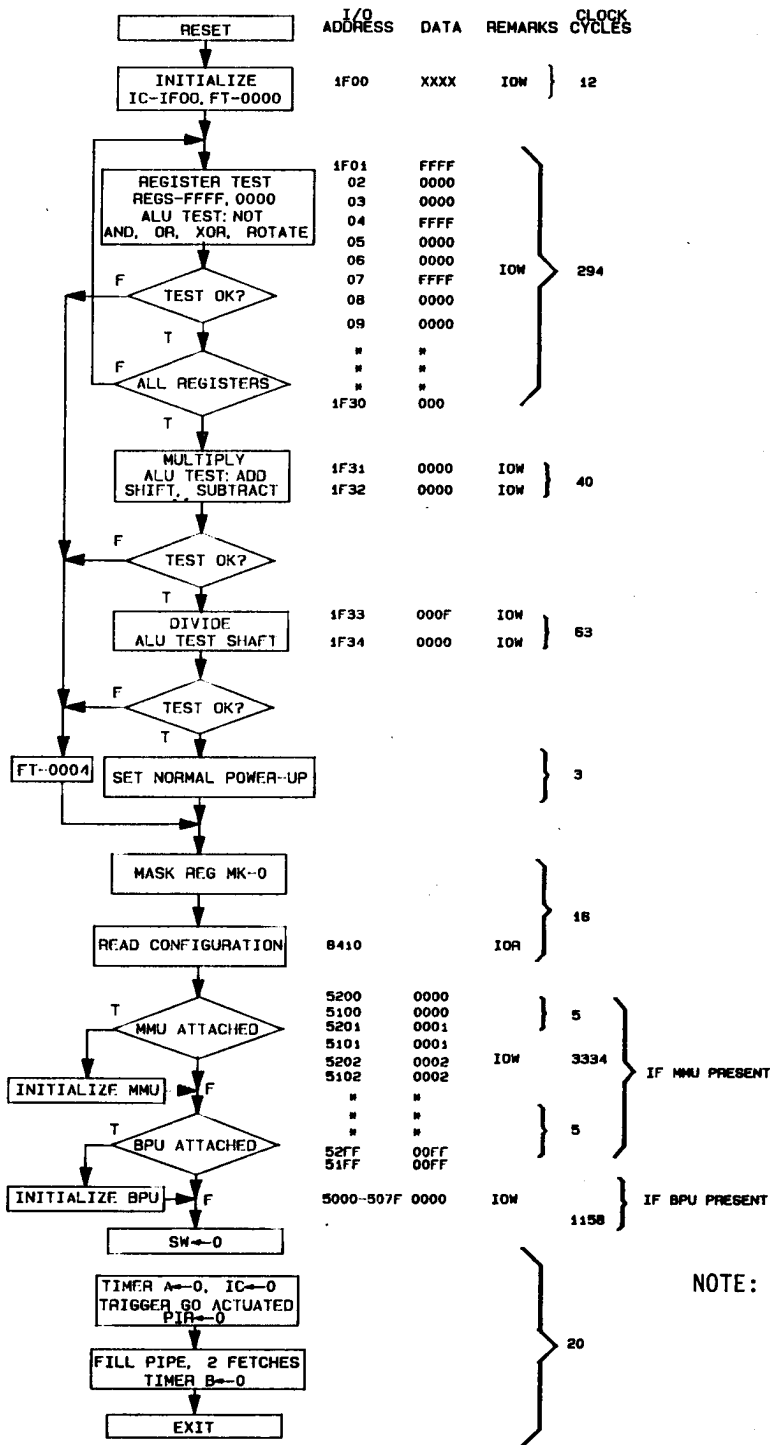

NOTE: The purpose of the I/O Write (IOW) addresses is to inform the user of the presently executed instruction in the self-test program. The user must furnish bus control signals to the CPU to enable it to continue the self-test sequence.

STANDARDIZED MILITARY DRAWING DEFENSE ELECTRONICS SUPPLY CENTER DAYTON, OHIO 45444	SIZE A		84169
		REVISION LEVEL A	SHEET 37

4. QUALITY ASSURANCE PROVISIONS

4.1 Sampling and inspection. Sampling and inspection procedures shall be in accordance with section 4 of MIL-M-38510 to the extent specified in MIL-STD-883 (see 3.1 herein). In addition, a device shall be submitted once every 12 months of production to WPAFB (SEAFAC) for verification to MIL-STD-1750 VSW test V 2.1 + 2 (see 3.7). For device types 02, 03, and 04, MIL-STD-1750 VSW test V 2.1 + 12 is applicable. The results of such testing shall be reported to DESC-ECS.

4.2 Screening. Screening shall be in accordance with method 5004 of MIL-STD-883, and shall be conducted on all devices prior to quality conformance inspection. The following additional criteria shall apply:

- a. Burn-in test, method 1015 of MIL-STD-883.
 - (1) Test condition C or D using the circuit submitted with the certificate of compliance (see 3.5 herein).
 - (2) $T_A = +125^{\circ}\text{C}$, minimum.
- b. Interim and final electrical test parameters shall be as specified in table II herein, except interim electrical parameter tests prior to burn-in are optional at the discretion of the manufacturer.
- c. Subgroup 12 shall be added and shall consist of the MIL-STD-1750 VSW test at V 2.1 + 2 deterministic portion only, at room ambient (see 3.7). For device types 02, 03, and 04, MIL-STD-1750 VSW test V 2.1 + 12 is applicable.

4.3 Quality conformance inspection. Quality conformance inspection shall be in accordance with method 5005 of MIL-STD-883 including groups A, B, C, and D inspections. The following additional criteria shall apply.

4.3.1 Group A inspection.

- a. Tests shall be as specified in table II herein.
- b. Subgroups 4, 5, and 6 in table I, method 5005 of MIL-STD-883 shall be omitted.
- c. Subgroups 7 and 8 functional testing shall include verification of instruction set.
- d. Subgroup 13 shall be added and shall consist of the MIL-STD-1750 VSW test V 2.1 + 2, deterministic portion only, at -55°C instant on and $+125^{\circ}\text{C}$ T_C (see 3.7). For device types 02, 03, and 04, MIL-STD-1750 VSW test V 2.1 + 12 is applicable.

4.3.2 Groups C and D inspections.

- a. End-point electrical parameters shall be as specified in table II herein. Devices which have passed subgroups 1, 2, and 3 in table I and the device functional built-in test and operate at greater than or equal to 12 MHz may be used for destructive quality conformance inspection testing (QCI) provided subject parts are identified as NONSHIPPABLE parts and the noncompliant electricals from subgroups 9, 10, and 11 are identified through the remainder of testing. Group D inspection electrical test end points shall be subgroups 1, 2, and 3 and the device built-in test. (The devices defined herein shall be for group D end points only.)

STANDARDIZED MILITARY DRAWING DEFENSE ELECTRONICS SUPPLY CENTER DAYTON, OHIO 45444	SIZE A	84169
	REVISION LEVEL A	SHEET 38

- b. Steady-state life test conditions, method 1005 of MIL-STD-883.
- (1) Test condition C or D using the circuit submitted with the certificate of compliance (see 3.5 herein).
 - (2) $T_A = +125^{\circ}\text{C}$, minimum.
 - (3) Test duration: 1,000 hours, except as permitted by method 1005 of MIL-STD-883.
- c. Subgroup 13 shall be added and will be as defined in 4.3.1d.

TABLE II. Electrical test requirements.

MIL-STD-883 test requirements	Subgroups (per method 5005, table I)
Interim electrical parameters (method 5004)	---
Final electrical test parameters (method 5004)	1*,2,3,7,8,9, 10**,11**,12
Group A test requirements (method 5005)	1,2,3,7,8,9, 10**,11**,13
Groups C and D end-point electrical parameters (method 5005)	1,2,3
Additional electrical subgroups for group C periodic inspections	7,8,9,10**, 11**,13

* PDA applies to subgroup 1.

** Subgroups 10 and 11, if not tested, shall be guaranteed.

5. PACKAGING

5.1 Packaging requirements. The requirements for packaging shall be in accordance with MIL-M-38510.

6. NOTES

6.1 Intended use. Microcircuits conforming to this drawing are intended for use when military specifications do not exist and qualified military devices that will perform the required function are not available for OEM application. When a military specification exists and the product covered by this drawing has been qualified for listing on QPL-38510, the device specified herein will be inactivated and will not be used for new design. The QPL-38510 product shall be the preferred item for all applications.

6.2 Replaceability. Replaceability is determined as follows:

- a. Microcircuits covered by this drawing will replace the same generic device covered by a contractor-prepared specification or drawing.
- b. When a QPL source is established, the part numbered device specified in this drawing will be replaced by the microcircuit identified as part number M38510/550XXXXX.

6.3 Comments. Comments on this drawing should be directed to DESC-ECS, Dayton, Ohio 45444, or telephone 513-296-5375.

STANDARDIZED MILITARY DRAWING DEFENSE ELECTRONICS SUPPLY CENTER DAYTON, OHIO 45444	SIZE A		84169
		REVISION LEVEL A	SHEET 39

DESC FORM 193A
SEP 87

* U. S. GOVERNMENT PRINTING OFFICE: 1988-549-904

6.4 Definitions.

Mnemonic	Pin no.	Name	Description
<u>Clocks</u>			
CPU CLK	51	CPU clock	Single-phase input clock signal (15 MHz, 40 percent to 60 percent duty cycle).
TIMER CLK	7	Timer clock	A 100 kHz input that, after synchronization with CPU, CLK, provides the clock for Timer A and Timer B. If timers are used, the CPU CLK signal frequency must be > 500 kHz (40 percent to 60 percent duty cycle).
<u>External Requests</u>			
RESET	5	Reset	An active-low input that initializes the device. The processor must be RESET after input power (V_{CC} , I_{INJ}) is within specification and stable to insure proper operation.
CONREQ	2	Console request	An active-low input that initiates console operations after the current instruction.
<u>Interrupts</u>			
PWRDN INT	33	Power down interrupt	An input interrupt request that cannot be masked or disabled. This signal is active on the positive-going edge or the high level, according to the interrupt mode bit in the configuration register. This input has hysteresis circuitry for noise immunity.
USR ₀ INT- USR ₅ INT	34-39	User interrupt	Input signals that are active on the positive-going edge or high level, according to the interrupt mode bit in the configuration register. These inputs have hysteresis circuitry for noise immunity.
IOL ₁ INT IOL ₂ INT	40,41	I/O level interrupts	Active-high inputs that can be used to expand number of user interrupts.
<u>Faults</u>			
MEM PRT ER	26	Memory protect error	An active-low input generated by the MMU or BPU, or both, and sampled by the BUS BUSY signal into the fault register (bit 0 if CPU bus cycle, bit 1 if non-CPU bus cycle).
PAR ER	27	Parity error	An active-low input sampled by the BUS BUSY signal into bit 2 of the fault register.
EXT ADR ER	28	External address error	An active-low input sampled by the BUS BUSY signal into the fault register (bit 5 or 8), depending on the cycle (memory or I/O).

STANDARDIZED MILITARY DRAWING DEFENSE ELECTRONICS SUPPLY CENTER DAYTON, OHIO 45444	SIZE A	84169
	REVISION LEVEL A	SHEET 40

DESC FORM 193A
SEP 87

* U. S. GOVERNMENT PRINTING OFFICE: 1988-549-904

Mnemonic	Pin no.	Name	Description
SYSFLT ₀ SYSFLT ₁	29,30	System fault 0 System fault 1	Asynchronous, positive-edge-sensitive inputs to the device that set bit 7 (SYSFLT ₀) or bits 13 and 15 (SYSFLT ₁) in the fault register. These inputs are protected from system noise through hysteresis circuitry.
<u>Information bus</u>			
IB ₀ -IB ₁₅	9-18 20-25	Information bus	An active-high bidirectional time-multiplexed address/data bus that is 3-state during bus cycles not assigned to this CPU; IB ₀ is the most significant bit.
<u>Status bus</u>			
AK ₀ -AK ₃	47-50	Access key	Active-high outputs used to match the access lock in the MMU for memory accesses (a mismatch is one of several possible situations that cause the MMU to pull the MEM PRT ER signal low. These signals are 3-state during bus cycles not assigned to this CPU.
AS ₀ -AS ₃	42-45	Address state	Active-high outputs that select the page register group in the MMU; 3-state bus during bus cycles not assigned to this CPU. These outputs together with \bar{D}/I can be used to expand the device's direct addressing range to 2M words.
<u>Error control</u>			
UNRCV ER	8	Unrecoverable error	An active-high output that indicates the occurrence of an error classified as unrecoverable.
MAJ ER	31	Major error	An active-high output indicating the occurrence of an error classified as major.
<u>Discrete control</u>			
DMA EN	3	Direct memory access enable	An active-high output that indicates the DMA is enabled. It is disabled when the CPU is initialized (reset) and is enabled under program control.
NML PWRUP	6	Normal power up	An active-high output that is set when the CPU has successfully completed the built-in test in the initialization sequence.
SNEW	63	Start new	An active-high output that indicates a new instruction will start executing in the next cycle; useful for instruction tracing function. Signal valid at frequencies up to 1/2 F _{max} .
STANDARDIZED MILITARY DRAWING DEFENSE ELECTRONICS SUPPLY CENTER DAYTON, OHIO 45444		SIZE A	84169
		REVISION LEVEL A	SHEET 41

DESC FORM 193A
SEP 87

★ U. S. GOVERNMENT PRINTING OFFICE: 1988-549-904

Mnemonic	Pin no.	Name	Description
<u>Discrete control</u> - continued			
TRIGO RST	4	Trigger go reset	An active-low discrete output. This signal can be pulsed low under program control I/O address 400B (Hex) and is automatically pulsed once during processor initialization.
<u>Bus control</u>			
D/T	58	Data or instruction	An output signal that indicates whether the current bus cycle access is for data (high) or instruction (low); 3-state during bus cycles not assigned to this CPU. This line can be used as an additional memory address bit for systems that require separate data and program memory.
R/ \bar{W}	57	Read or write	An output signal that indicates direction of data flow with respect to the current bus master: a high indicates a read or input operation and a low indicates a write or output operation. The signal is 3-state during bus cycles not assigned to this CPU.
M/ $\bar{I/O}$	59	Memory or I/O	Output signal that indicates whether the current bus cycle is memory (high) or I/O (low). This signal is 3-state during bus cycles not assigned to this CPU.
STRBA	52	Address strobe	An active-high output that can be used to externally latch the memory or I/O address at the high-to-low transition of the strobe. The signal is 3-state during bus cycles not assigned to this CPU.
RDYA	55	Address ready	An active-high input that can be used to extend the address phase of a bus cycle. When RDYA is not active, wait states are inserted by the device's timing unit to accommodate slower memory or I/O devices.
STRBD	53	Data strobe	An active-low output that can be used to strobe data in memory and XIO cycles. The signal is 3-state during bus cycles not assigned to this CPU.
RDYD	56	Data ready	An active-high input that extends the data phase of a bus cycle. When RDYD is not active, wait states are inserted by the device's timing unit to accommodate slower memory or I/O devices.
<u>Bus arbitration</u>			
BUS REQ	54	Bus request	An active-low output that indicates the CPU requires the bus; becomes inactive when the CPU has acquired the bus and started the bus cycle.
STANDARDIZED MILITARY DRAWING DEFENSE ELECTRONICS SUPPLY CENTER DAYTON, OHIO 45444		SIZE A	84169
		REVISION LEVEL A	SHEET 42

DESC FORM 193A
SEP 87

* U. S. GOVERNMENT PRINTING OFFICE: 1988-549-904

Mnemonic	Pin no.	Name	Description
<u>Bus arbitration - continued.</u>			
BUS GNT	61	Bus grant	An active-low input from an external arbiter that indicates the CPU currently has the highest priority bus request. If the bus is not locked, the CPU may begin a bus cycle, commencing with the next CPU clock.
BUS BUSY	60	Bus busy	An active-low bidirectional signal used to establish the beginning and end of a bus cycle. The trailing edge (low-to-high transition) is used for sampling bits into the fault register. It is 3-state in bus cycles not assigned to this CPU; however, the CPU monitors the BUS BUSY line for latching non-CPU bus-cycle faults into the fault register.
BUS LOCK	62	Bus-lock	An active-low bidirectional signal used to lock the bus for successive bus cycles. During non-locked bus cycles, the BUS LOCK signal mimics the BUS BUSY signal. It is 3-state during bus cycles not assigned to this CPU. The following instructions will lock the bus: INCM, DECM, SB, RB, TSB, SRM, STUB, STLB.
<u>Power</u>			
VCC	64	Power supply	+5 V, 270 mA typical power supply.
GND	1, 32	Ground	0 V reference. These pins should be tied together as close to the chip as possible.
IINJ1, IINJ2	19 46	Injector current	Current source to provide bias for the injection logic. These pins should be tied together as close to the chip as possible.
<u>Timing characteristics.</u>			
The abbreviated symbol convention used for timing parameters in this drawing is $t_{Ab(C)d}$, where:			
Timing symbols all begin with the letter "t".			
The mnemonic in the position represented by "A" indicates the signal node beginning the interval.			
The mnemonic in the position represented by "b" defines the direction of signal transition at the the beginning node, if such definition is necessary; the new state of the signal may be low (l), high (h), 3-state (z), don't care (x), or valid (v).			
The mnemonic in the position represented by "(C)", which always appears in the parentheses, indicates the signal node ending the interval.			
The mnemonic in the position represented by "d" is the same as "b", but refers to the state of the signal at the node indicated by the mnemonic in position "(C)".			
The mnemonics in the positions represented by "b" and "d" are not used for reference to the CPU CLK signal, as it is assumed to be active on the rising edge.			
For example, $t_{f(BB)}$ is the setup time from a valid fault (EXT ADR ER, MEM PRT ER, PAR ER) input to BUS BUSY.			
STANDARDIZED MILITARY DRAWING DEFENSE ELECTRONICS SUPPLY CENTER DAYTON, OHIO 45444		SIZE A	84169
		REVISION LEVEL A	SHEET 43

DESC FORM 193A
SEP 87

* U. S. GOVERNMENT PRINTING OFFICE: 1988-549-904

6.5 Approved source of supply. An approved source of supply is listed herein. Additional sources will be added as they become available. The vendor listed herein has agreed to this drawing and a certificate of compliance (see 3.5) has been submitted to DESC-ECS.

Military drawing part number	Vendor CAGE number	Vendor similar part number <u>1/</u>	Replacement military specification part number
8416901XX	27014	F9450-15DMQB	M38510/550XXBXX
8416901YX	27014	F9450-15GMQB	M38510/550XXBXX
8416902XX	27014	F9450-F18DMQB	M38510/550XXBXX
8416902YX	27014	F9450-F18GMQB	M38510/550XXBXX
8416903XX	27014	F9450-F20DMQB	M38510/550XXBXX
8416903YX	27014	F9450-F20GMQB	M38510/550XXBXX
8416904XX	27014	F9450-F15DMQB	M38510/550XXBXX
8416904YX	27014	F9450-F15GMQB	M38510/550XXBXX

1/ Caution. Do not use this number for item acquisition. Items acquired to this number may not satisfy the performance requirements of this drawing.

Vendor CAGE number

27014

Vendor name and address

National Semiconductor Corporation
2900 Semiconductor Drive
Santa Clara, CA 95052-8090

STANDARDIZED MILITARY DRAWING DEFENSE ELECTRONICS SUPPLY CENTER DAYTON, OHIO 45444	SIZE A		84169
		REVISION LEVEL A	SHEET 44

DESC FORM 193A
SEP 87

012677 - - -

* U. S. GOVERNMENT PRINTING OFFICE: 1988-549-904