

PLEASE CHECK WWW.MOLEX.COM FOR LATEST PART INFORMATION

Part Number: [0015249165](#)
Status: **Active**
Description: 4.20mm (.165") Pitch Mini-Fit BMI™ Header, Dual Row, Right Angle, with Snap-in Plastic Peg PCB Lock, 16 Circuits, PA Polyamide Nylon 6/6 94V-0, with Gold (Au) Plating

Documents:

[3D Model](#) [Product Specification PS-5556-002 \(PDF\)](#)
[Drawing \(PDF\)](#) [RoHS Certificate of Compliance \(PDF\)](#)

Agency Certification

CSA LR19980
 UL E29179

General

Product Family PCB Headers
 Series [42404](#)
 Application Board-to-Board, Wire-to-Board
 Comments Current = 13A max. per circuit when header is mated to a receptacle loaded with [45750](#) Mini-Fit Plus HCS™ Crimp Terminal Crimped to to 16 AWG wire. . See Molex product specification PS-45750-001 for additional current de-rating information.. Square Pin, Solder Type, High Vibration Application
 Product Name Mini-Fit BMI™

Physical

Breakaway No
 Circuits (Loaded) 16
 Circuits (maximum) 16
 Color - Resin Natural (White)
 Durability (mating cycles max) 30
 Flammability 94V-0
 Glow-Wire Compliant No
 Material - Metal Brass
 Material - Plating Mating Gold
 Material - Plating Termination Gold
 Material - Resin Nylon
 Number of Rows 2
 Orientation Right Angle
 PC Tail Length (in) 0.130 In
 PC Tail Length (mm) 3.30 mm
 PCB Locator Yes
 PCB Retention Yes
 PCB Thickness Recommended (in) 0.070 In
 PCB Thickness Recommended (mm) 1.80 mm
 Packaging Type Tray
 Pitch - Mating Interface (in) 0.165 In
 Pitch - Mating Interface (mm) 4.20 mm
 Plating min: Mating (µin) 30.4
 Plating min: Mating (µm) 0.76
 Plating min: Termination (µin) 30.4
 Plating min: Termination (µm) 0.76
 Polarized to PCB Yes
 Shrouded Partial
 Stackable No

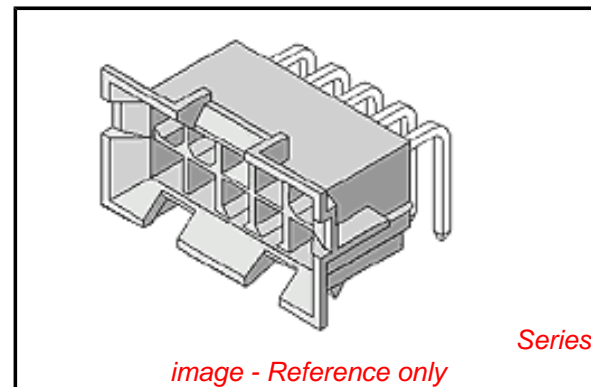

EU RoHS

ELV and RoHS Compliant
REACH SVHC
 Not Reviewed
Halogen-Free Status
Not Reviewed

China RoHS



Need more information on product environmental compliance?

Email productcompliance@molex.com
 For a multiple part number RoHS Certificate of Compliance, [click here](#)

Please visit the [Contact Us](#) section for any non-product compliance questions.

Search Parts in this Series

[42404Series](#)

Mates With

[42385](#) , [42474](#) , [44475](#) , [44516](#) , [5557d](#)

Surface Mount Compatible (SMC)	No
Temperature Range - Operating	-40°C to +105°C
Termination Interface: Style	Through Hole

Electrical

Current - Maximum per Contact	13A
Voltage - Maximum	600V

Solder Process Data

Duration at Max. Process Temperature (seconds)	5
Lead-free Process Capability	Wave Capable (TH only)
Max. Cycles at Max. Process Temperature	1
Process Temperature max. C	240

Material Info

Old Part Number	A-42404-16B2
-----------------	--------------

Reference - Drawing Numbers

Packaging Specification	PK-42404-002
Product Specification	PS-5556-002
Sales Drawing	SDA-42404-****
Test Summary	TS-5556-002

This document was generated on 05/11/2010

PLEASE CHECK WWW.MOLEX.COM FOR LATEST PART INFORMATION

CIRCUIT SIZE	DIM. "A"	DIM. "B"
6	.331 (8.40)	.76 (19.2)
8	.496 (12.60)	.92 (23.4)
10	.661 (16.80)	1.09 (27.6)
12	.827 (21.00)	1.25 (31.8)
14	.992 (25.20)	1.42 (36.0)
16	1.157 (29.40)	1.58 (40.2)
18	1.323 (33.60)	1.75 (44.4)
20	1.488 (37.80)	1.91 (48.6)
22	1.654 (42.00)	2.08 (52.8)
24	1.819 (46.20)	2.24 (57.0)

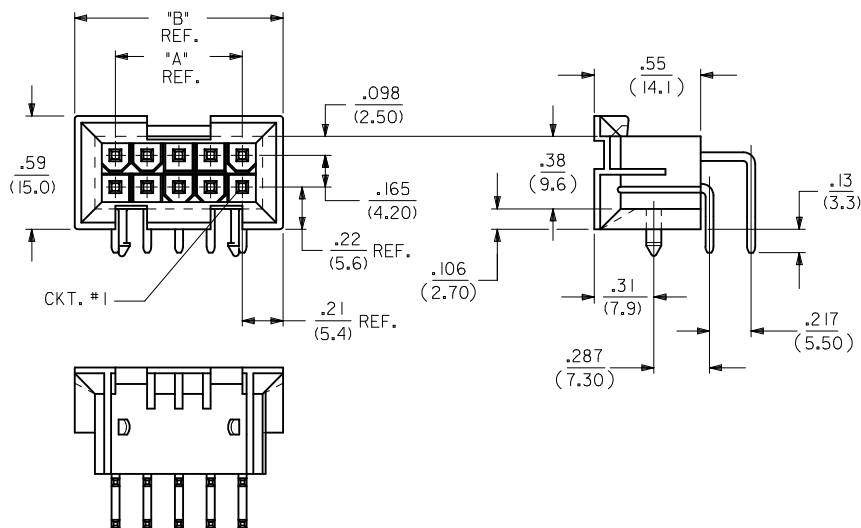

NOTES:

- MATERIAL: HOUSING: "A" = NYLON 6/6, U.L. 94V-2, COLOR: NATURAL. "B" = NYLON 6/6, U.L. 94V-0, COLOR: NATURAL. TERMINAL: BRASS ALLOY 260.
- TERMINAL PLATING:
 - .000100/(.00254) MIN. BRIGHT TIN OVER .000050/(.00127) MIN. NICKEL OVERALL.
 - .000030/(.00076) MIN. GOLD OVER .000050/(.00127) MIN. NICKEL OVERALL.
 - *.000100/(.00254) MIN. MATTE TIN OVER .000050/(.00127) MIN. NICKEL OVERALL.
 - .000030/(.00076) MIN. GOLD AND .000100/(.00254) MIN. MATTE TIN OVER .000050/(.00127) MIN. NICKEL OVERALL.

*THE PRIMARY SHIPPING CARTON WILL BE LABELED "COMPLIANT TO RoHS DIRECTIVE 2002/95/EC AND ELV ANNEX II OF DIRECTIVE 2000/53/EC." CARTONS WITHOUT THIS LABEL MAY CONTAIN PRODUCT WITH TIN-LEAD PLATING.
- PRODUCT SPECIFICATION AND PROCESSING PARAMETERS: SEE PS-5556-002
- PACKAGING SPECIFICATION: PK-42404-002.
- 4-24 CKT. PARTS MATE WITH MINI-FIT JR. RECEPTACLES #5557, #42385 AND #42474. 2 CKT. PART MATES WITH #42385 AND #42474 ONLY.
- PART ALLOWS FOR UP TO .100/(2.54) MISALIGNMENT WITH MATING RECEPTACLE IN ANY DIRECTION. SEE MATING CONNECTOR DRAWINGS FOR SPECIFIC ALLOWANCES.
- CONNECTOR ASSEMBLIES ARE NOT TO BE MATED OR UNMATED WHILE CIRCUITS ARE LIVE.
- A MAXIMUM TOLERANCE OF .050/(1.27) ALLOWS FOR 2 POINTS OF ELECTRICAL CONTACT. A MAXIMUM TOLERANCE OF .020/(.51) ALLOWS FOR 4 POINTS OF CONTACT.
- DISCOLORATION IN THE BANDOLIER CARRIER AREA OF THE PIN IS INHERENT TO THE PLATING PROCESS AND IS DUE TO THE MASKING EFFECT OF THE CARRIER. THIS DISCOLORATION IS IN A NON-FUNCTIONAL AREA OF THE PIN AND WILL NOT AFFECT THE PERFORMANCE OF THE HEADER ASSEMBLY.
- PART IS NOT DESIGNED FOR CURRENT SHARING.
- PART IS NOT INTENDED TO PROVIDE ANY ALIGNMENT OF CUSTOMER COMPONENTS OR MODULES, SUCH AS POWER SUPPLIES AND CHASSIS.
- PARTS CONFORM TO CLASS 'B' REQUIREMENTS OF COSMETIC SPECIFICATION PS-45499-002.*

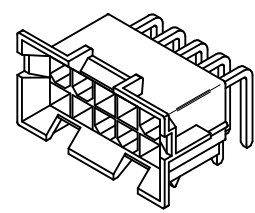

A-42404-****

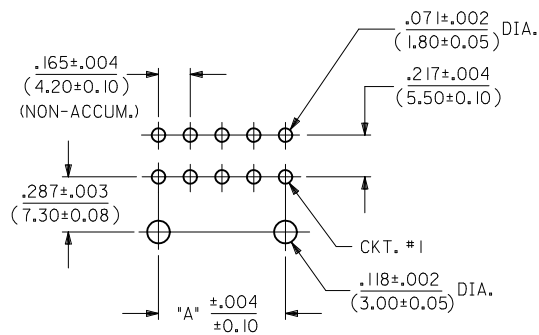

RECOMMENDED HOLE LAYOUT FOR .070/(1.78) MAX. THICK P.C. BOARD VIEWED FROM COMPONENT SIDE

LEGEND:

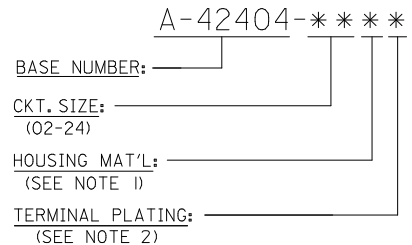

CKT. SIZE	HOUSING MAT'L	TERMINAL MAT'L	PLATING
2-4	PHOS. BRZ.	BRASS	GOLD
2-4	PHOS. BRZ.	BRASS	TIN
2-4	PHOS. BRZ.	BRASS	GOLD
2-4	PHOS. BRZ.	BRASS	TIN
2-4	PHOS. BRZ.	BRASS	GOLD
2-4	PHOS. BRZ.	BRASS	TIN
2-4	PHOS. BRZ.	BRASS	GOLD
2-4	PHOS. BRZ.	BRASS	TIN
2-4	PHOS. BRZ.	BRASS	GOLD
2-4	PHOS. BRZ.	BRASS	TIN

DESCRIPTION	REVISION
R.A. HEADER A-42404	R2
MATING CONNECTOR	
HSG. MAT'L, TERM. MAT'L, PLATING	
MATING CONNECTOR FEATURES	

REVISE NOTES EC NO: UCP2010-0864 DRWNG: JAGUILAR 2010/01/18 CHKD: JEBEL 2010/01/06 APPR: FSMITH 2010/03/16 DESCRIPTION REV	QUALITY SYMBOLS ▽=0 ▽=0	GENERAL TOLERANCES (UNLESS SPECIFIED)		DIMENSION STYLE IN/MM		SCALE 1:1	DESIGN UNITS METRIC	THIRD ANGLE PROJECTION	
		mm INCH		DRAWN BY RWK	DATE 2/7/89	TITLE MINI-FIT JR. 2-24 CKT RIGHT ANGLE HEADER ASSY (BLIND MATE)			
		4 PLACES ± --- ± --- 3 PLACES ± --- ± .010 2 PLACES ± 0.25 ± .015 1 PLACE ± 0.38 ± ---		CHECKED BY RJF	DATE 2/7/89	MOLEX MOLEX INCORPORATED			
		ANGULAR ±1/2°		APPROVED BY FSMITH	DATE 2010/03/16	MATERIAL NO. SEE SHTS 3&4	DOCUMENT NO. SDA-42404-****	SHEET NO. 1 OF 4	
DRAFT WHERE APPLICABLE MUST REMAIN WITHIN DIMENSIONS								THIS DRAWING CONTAINS INFORMATION THAT IS PROPRIETARY TO MOLEX INCORPORATED AND SHOULD NOT BE USED WITHOUT WRITTEN PERMISSION	

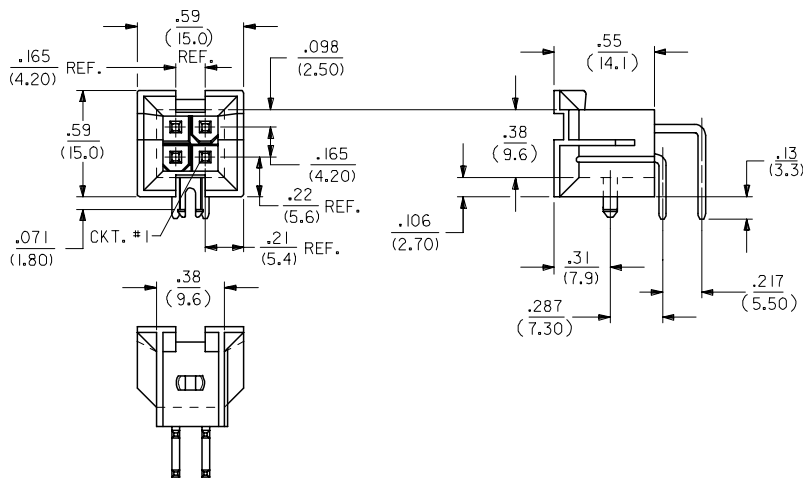

A-42404-04**

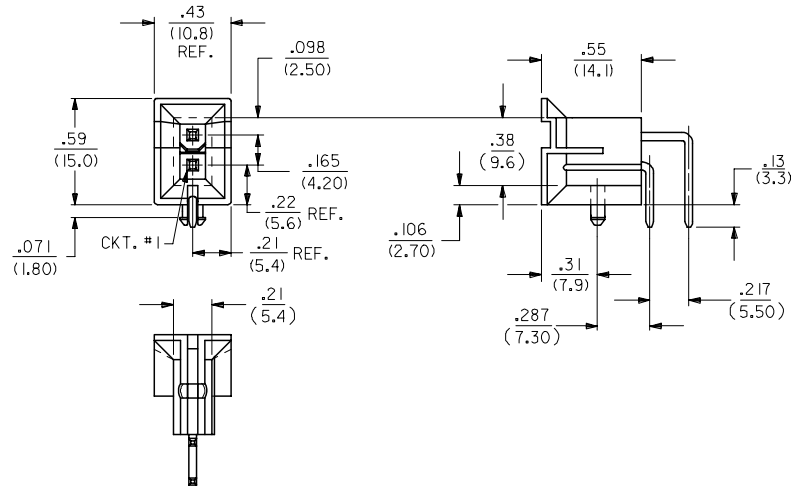

A-42404-02**

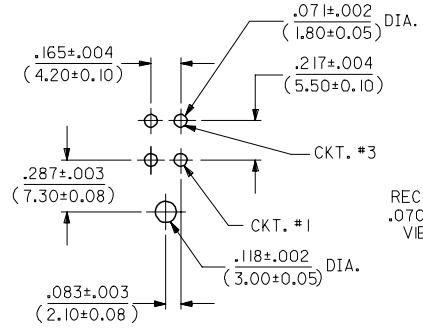

RECOMMENDED HOLE LAYOUT FOR
.070/(1.78) MAX. THICK P.C. BOARD
VIEWED FROM COMPONENT SIDE

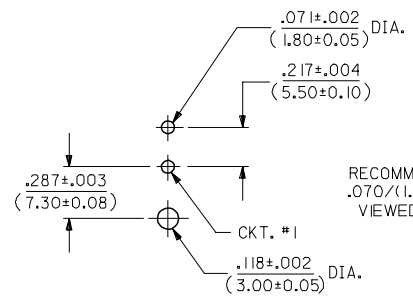

RECOMMENDED HOLE LAYOUT FOR
.070/(1.78) MAX. THICK P.C. BOARD
VIEWED FROM COMPONENT SIDE

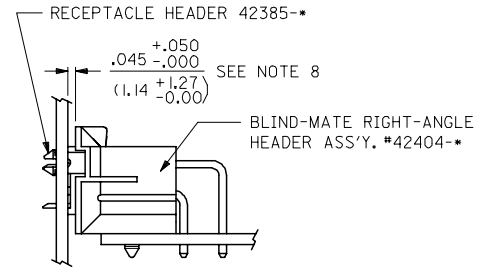

PANEL-TO-P.C.BOARD

SEE SHEET 1 FC NO: UCP2006-1780 DRAWN: ADRIANOL 2006/02/03 CHKD: GPOLGAR 2006/02/03 APPR: ICOMERCJ 2006/02/06 REV:	QUALITY SYMBOLS ▽=0 ▽=0	GENERAL TOLERANCES (UNLESS SPECIFIED) 4 PLACES ± --- ± --- 3 PLACES ± --- ± .01 2 PLACES ± 0.25 ± .015 1 PLACE ± 0.38 ± --- ANGULAR ±1/2°	DIMENSION STYLE IN/MM DRAWN BY: RWK CHECKED BY: RJF APPROVED BY: RAS MATERIAL NO.	DATE: 1989/02/07 DATE: 1989/02/07 DATE: 1989/02/07	SCALE: 2:1 DESIGN UNITS: METRIC THIRD ANGLE PROJECTION	TITLE: MINI-FIT JR. 2-24 CKT RIGHT ANGLE HEADER ASSY (BLIND MATE)
	DRAFT WHERE APPLICABLE MUST REMAIN WITHIN DIMENSIONS			MOLEX INCORPORATED	SHEET NO. 2 OF 4	DOCUMENT NO. SDA-42404-****
	THIS DRAWING CONTAINS INFORMATION THAT IS PROPRIETARY TO MOLEX INCORPORATED AND SHOULD NOT BE USED WITHOUT WRITTEN PERMISSION					
	SEE SHTS 3&4					

REMOVE PLATE CODE
EC NO: UCP2010-0864
DRWN: JAGUILAR 2010/01/18
CHKD: J.BELL 2010/01/06
APPR: FSMITH 2010/03/16

REVISIONS
R2

QUALITY SYMBOLS

 GENERAL TOLERANCES (UNLESS SPECIFIED)

	mm	INCH
4 PLACES	± .005	± .0002
3 PLACES	± .005	± .0002
2 PLACES	± .005	± .0002
1 PLACE	± .005	± .0002

 ANGULAR ±1/2°
 DRAFT WHERE APPLICABLE
 MUST REMAIN WITHIN DIMENSIONS

DIMENSION STYLE
IN/MM
 DRAWN BY DATE
 RWK 1989/02/08
 CHECKED BY DATE
 RJF 1989/02/08
 APPROVED BY DATE
 FSMITH 2010/03/16

SCALE

 DESIGN UNITS
METRIC

THIRD ANGLE PROJECTION
 TITLE
**MINI-FIT JR. 2-24 CKT
 RIGHT ANGLE HEADER ASSY
 (BLIND MATE)**

MOLEX INCORPORATED
 MATERIAL NO. **SEE CHARTS**
 DOCUMENT NO. **SDA-42404-******
 SHEET NO. **3 OF 4**
 THIS DRAWING CONTAINS INFORMATION THAT IS PROPRIETARY TO MOLEX INCORPORATED AND SHOULD NOT BE USED WITHOUT WRITTEN PERMISSION

C	D	E	F	G	H	I	J		
PART NUMBER	ENG. NUMBER	CKT. SIZE	HOUSING MATERIAL	PLATING (NOTE 5)	PART NUMBER	ENG. NUMBER	CKT. SIZE	HOUSING MATERIAL	PLATING (NOTE 5)
NOT TOOLED	A-42404-02A1	2	94V-2	BRIGHT TIN OVER NICKEL	NOT TOOLED	A-42404-02A3	2	94V-2	MATTE TIN OVER NICKEL
I5-24-6040	-04A1	4			NOT TOOLED	-04A3	4		
I5-24-6060	-06A1	6			NOT TOOLED	-06A3	6		
NOT TOOLED	-08A1	8			NOT TOOLED	-08A3	8		
I5-24-6100	-10A1	10			NOT TOOLED	-10A3	10		
NOT TOOLED	-12A1	12			NOT TOOLED	-12A3	12		
I5-24-6140	-14A1	14			NOT TOOLED	-14A3	14		
NOT TOOLED	-16A1	16			NOT TOOLED	-16A3	16		
I5-24-6180	-18A1	18			NOT TOOLED	-18A3	18		
NOT TOOLED	-20A1	20			NOT TOOLED	-20A3	20		
NOT TOOLED	-22A1	22			NOT TOOLED	-22A3	22		
I5-24-6240	A-42404-24A1	24	94V-2	BRIGHT TIN OVER NICKEL	NOT TOOLED	A-42404-24A3	24	94V-2	MATTE TIN OVER NICKEL
NOT TOOLED	A-42404-02A2	2	94V-2	30 M.I. GOLD					
I5-24-9043	-04A2	4							
I5-24-9063	-06A2	6							
NOT TOOLED	-08A2	8							
I5-24-9103	-10A2	10							
NOT TOOLED	-12A2	12							
I5-24-9143	-14A2	14							
NOT TOOLED	-16A2	16							
I5-24-9183	-18A2	18							
NOT TOOLED	-20A2	20							
NOT TOOLED	-22A2	22							
I5-24-9243	A-42404-24A2	24	94V-2	30 M.I. GOLD					
NOT TOOLED	A-42404-02B1	2	94V-0	BRIGHT TIN OVER NICKEL					
I5-24-9044	-04B1	4							
I5-24-9064	-06B1	6							
NOT TOOLED	-08B1	8							
I5-24-9104	-10B1	10							
NOT TOOLED	-12B1	12							
I5-24-9144	-14B1	14							
I5-24-9164	-16B1	16							
I5-24-9184	-18B1	18							
NOT TOOLED	-20B1	20							
NOT TOOLED	-22B1	22							
I5-24-9244	A-42404-24B1	24	94V-0	BRIGHT TIN OVER NICKEL					
NOT TOOLED	A-42404-02B2	2	94V-0	30 M.I. GOLD					
I5-24-9045	-04B2	4							
I5-24-9065	-06B2	6							
NOT TOOLED	-08B2	8							
I5-24-9105	-10B2	10							
NOT TOOLED	-12B2	12							
I5-24-9145	-14B2	14							
I5-24-9165	-16B2	16							
I5-24-9185	-18B2	18							
NOT TOOLED	-20B2	20							
NOT TOOLED	-22B2	22							
I5-24-9245	A-42404-24B2	24	94V-0	30 M.I. GOLD					

C	D	E	F	G	H	I	J		
PART NUMBER	ENG. NUMBER	CKT. SIZE	HOUSING MATERIAL	PLATING (NOTE 5)	PART NUMBER	ENG. NUMBER	CKT. SIZE	HOUSING MATERIAL	PLATING (NOTE 5)
NOT TOOLED	A-42404-02A1	2	94V-2	BRIGHT TIN OVER NICKEL	NOT TOOLED	A-42404-02A3	2	94V-2	MATTE TIN OVER NICKEL
I5-24-6040	-04A1	4			NOT TOOLED	-04A3	4		
I5-24-6060	-06A1	6			NOT TOOLED	-06A3	6		
NOT TOOLED	-08A1	8			NOT TOOLED	-08A3	8		
I5-24-6100	-10A1	10			NOT TOOLED	-10A3	10		
NOT TOOLED	-12A1	12			NOT TOOLED	-12A3	12		
I5-24-6140	-14A1	14			NOT TOOLED	-14A3	14		
NOT TOOLED	-16A1	16			NOT TOOLED	-16A3	16		
I5-24-6180	-18A1	18			NOT TOOLED	-18A3	18		
NOT TOOLED	-20A1	20			NOT TOOLED	-20A3	20		
NOT TOOLED	-22A1	22			NOT TOOLED	-22A3	22		
I5-24-6240	A-42404-24A1	24	94V-2	BRIGHT TIN OVER NICKEL	NOT TOOLED	A-42404-24A3	24	94V-2	MATTE TIN OVER NICKEL