

ADM809/ADM810

FEATURES

Superior Upgrade for MAX809/MAX810
Specified over Temperature
Low Power Consumption (17 μ A)
Precision Voltage Monitor: 2.5 V, 3 V, 3.3 V, 5 V Options
Reset Assertion Down to 1 V V_{CC}
140 ms Min Power-On Reset
Logic Low RESET Output (ADM809)
Logic High RESET Output (ADM810)
SC70 and SOT-23 Packages

APPLICATIONS

Microprocessor Systems
Computers
Controllers
Intelligent Instruments
Automotive Systems

GENERAL DESCRIPTION

The ADM809/ADM810 supervisory circuits monitor the power supply voltage in microprocessor systems. They provide a reset output during power-up, power-down, and brownout conditions. On power-up, an internal timer holds reset asserted for 240 ms. This holds the microprocessor in a reset state until conditions have stabilized. The RESET output remains operational with V_{CC} as low as 1 V. The ADM809 provides an active low reset signal ($\overline{\text{RESET}}$), while the ADM810 provides an active high signal (RESET) output.

Seven reset threshold voltage options are available, suitable for monitoring a variety of supply voltages. Refer to Table I.

The reset comparator features built-in glitch immunity, making it immune to fast transients on V_{CC} .

The ADM809/ADM810 consumes only 17 μ A, making it suitable for low power portable equipment. It is packaged in 3-lead SC70 and SOT-23 packages.

FUNCTIONAL BLOCK DIAGRAM

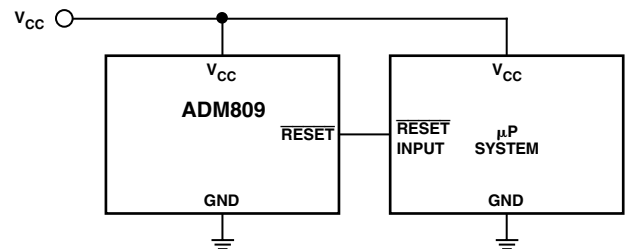
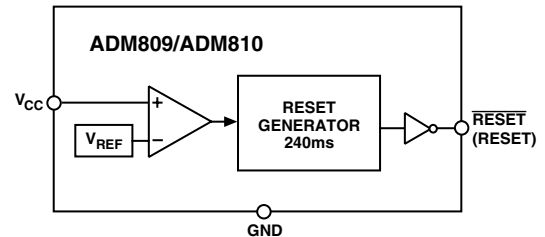

Figure 1. Typical Operating Circuit

REV. B

Information furnished by Analog Devices is believed to be accurate and reliable. However, no responsibility is assumed by Analog Devices for its use, nor for any infringements of patents or other rights of third parties that may result from its use. No license is granted by implication or otherwise under any patent or patent rights of Analog Devices. Trademarks and registered trademarks are the property of their respective companies.

ADM809/ADM810—SPECIFICATIONS

(V_{CC} = Full Operating Range, $T_A = T_{MIN}$ to T_{MAX} , V_{CC} Typ = 5 V for L/M/J, 3.3 V for T/S, 3 V for R models, 2.5 V for Z models, unless otherwise noted.)

Parameter	Min	Typ	Max	Unit	Test Conditions/Comments
V_{CC} Operating Voltage Range	1.0		5.5	V	$T_A = 0^\circ\text{C}$ to 70°C
Supply Current	1.2	24	5.5	V	$T_A = -40^\circ\text{C}$ to $+125^\circ\text{C}$
		17	30	μA	$V_{CC} < 5.5$ V, ADM8_L/M/J, $T_A = -40^\circ\text{C}$ to $+85^\circ\text{C}$
			60	μA	$V_{CC} < 3.6$ V, ADM8_R/S/T/Z, $T_A = -40^\circ\text{C}$ to $+85^\circ\text{C}$
			60	μA	$V_{CC} < 5.5$ V, ADM8_L/M/J, $T_A = 85^\circ\text{C}$ to 125°C
			60	μA	$V_{CC} < 3.6$ V, ADM8_R/S/T/Z, $T_A = 85^\circ\text{C}$ to 125°C
RESET THRESHOLD					
Reset Voltage Threshold					
ADM8_L	4.56	4.63	4.70	V	$T_A = 25^\circ\text{C}$
ADM8_L	4.50		4.75	V	$T_A = -40^\circ\text{C}$ to $+85^\circ\text{C}$
ADM8_L	4.44		4.82	V	$T_A = -40^\circ\text{C}$ to $+125^\circ\text{C}$
ADM8_M	4.31	4.38	4.45	V	$T_A = 25^\circ\text{C}$
ADM8_M	4.25		4.50	V	$T_A = -40^\circ\text{C}$ to $+85^\circ\text{C}$
ADM8_M	4.20		4.56	V	$T_A = -40^\circ\text{C}$ to $+125^\circ\text{C}$
ADM8_J	3.93	4.00	4.06	V	$T_A = 25^\circ\text{C}$
ADM8_J	3.89		4.10	V	$T_A = -40^\circ\text{C}$ to $+85^\circ\text{C}$
ADM8_J	3.80		4.20	V	$T_A = -40^\circ\text{C}$ to $+125^\circ\text{C}$
ADM8_T	3.04	3.08	3.11	V	$T_A = 25^\circ\text{C}$
ADM8_T	3.00		3.15	V	$T_A = -40^\circ\text{C}$ to $+85^\circ\text{C}$
ADM8_T	2.95		3.21	V	$T_A = -40^\circ\text{C}$ to $+125^\circ\text{C}$
ADM8_S	2.89	2.93	2.96	V	$T_A = 25^\circ\text{C}$
ADM8_S	2.85		3.00	V	$T_A = -40^\circ\text{C}$ to $+85^\circ\text{C}$
ADM8_S	2.81		3.05	V	$T_A = -40^\circ\text{C}$ to $+125^\circ\text{C}$
ADM8_R	2.59	2.63	2.66	V	$T_A = 25^\circ\text{C}$
ADM8_R	2.55		2.70	V	$T_A = -40^\circ\text{C}$ to $+85^\circ\text{C}$
ADM8_R	2.52		2.74	V	$T_A = -40^\circ\text{C}$ to $+125^\circ\text{C}$
ADM8_Z	2.28	2.32	2.35	V	$T_A = 25^\circ\text{C}$
ADM8_Z	2.25		2.38	V	$T_A = -40^\circ\text{C}$ to $+85^\circ\text{C}$
ADM8_Z	2.22		2.42	V	$T_A = -40^\circ\text{C}$ to $+125^\circ\text{C}$
Reset Threshold Temperature Coefficient		30		ppm/ $^\circ\text{C}$	
V_{CC} to Reset Delay		20		μs	$V_{CC} = V_{TH}$ to $(V_{TH} - 100$ mV)
Reset Active Timeout Period	140	240	460	ms	$T_A = -40^\circ\text{C}$ to $+85^\circ\text{C}$
	100		840	ms	$T_A = 85^\circ\text{C}$ to 125°C
$\overline{\text{RESET}}$ Output Voltage Low (ADM809)			0.3	V	$V_{CC} = V_{TH}$ min, $I_{SINK} = 1.2$ mA, ADM809R/S/T/Z
			0.4	V	$V_{CC} = V_{TH}$ min, $I_{SINK} = 3.2$ mA, ADM809L/M/J,
			0.3	V	$V_{CC} > 1.0$ V, $I_{SINK} = 50$ μA
$\overline{\text{RESET}}$ Output Voltage High (ADM809)	$0.8 V_{CC}$			V	$V_{CC} > V_{TH}$ max, $I_{SOURCE} = 500$ μA , ADM809R/S/T/Z
	$V_{CC} - 1.5$			V	$V_{CC} > V_{TH}$ max, $I_{SOURCE} = 800$ μA , ADM809L/M/J
RESET Output Voltage Low (ADM810)			0.3	V	$V_{CC} = V_{TH}$ min, $I_{SINK} = 1.2$ mA, ADM810R/S/T/Z
			0.4	V	$V_{CC} = V_{TH}$ min, $I_{SINK} = 3.2$ mA, ADM810L/M/J
RESET Output Voltage High (ADM810)	$0.8 V_{CC}$			V	1.8 V $< V_{CC} < V_{TH}$ min, $I_{SOURCE} = 150$ μA

Specifications subject to change without notice.

ABSOLUTE MAXIMUM RATINGS*

(T_A = 25°C, unless otherwise noted.)

V _{CC}	-0.3 V to +6 V
RESET, $\overline{\text{RESET}}$	-0.3 V to V _{CC} + 0.5 V
Input Current	
V _{CC}	20 mA
Output Current	
RESET, $\overline{\text{RESET}}$	20 mA
Rate of Rise, V _{CC}	100 V/μs
θ _{JA} Thermal Impedance, SC70	146°C/W
θ _{JA} Thermal Impedance, SOT-23	270°C/W
Lead Temperature (Soldering, 10 sec)	300°C
Vapor Phase (60 sec)	215°C
Infrared (15 sec)	220°C
Storage Temperature Range	-65°C to +150°C

*Stresses above those listed under Absolute Maximum Ratings may cause permanent damage to the device. This is a stress rating only; functional operation of the device at these or any other conditions above those listed in the operational sections of this specification is not implied. Exposure to absolute maximum ratings for extended periods of time may affect device reliability.

Table I. Reset Threshold Options

RESET Model	Threshold (V)
ADM809L	4.63
ADM809M	4.38
ADM809J	4.00
ADM809T	3.08
ADM809S	2.93
ADM809R	2.63
ADM809Z	2.32
ADM810L	4.63
ADM810M	4.38
ADM810J	4.00
ADM810T	3.08
ADM810S	2.93
ADM810R	2.63
ADM810Z	2.32

PIN CONFIGURATION

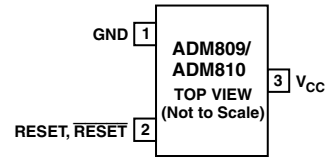

PIN FUNCTION DESCRIPTIONS

Pin No.	Mnemonic	Function
1	GND	0 V. Ground reference for all signals.
2	$\overline{\text{RESET}}$ (ADM809)	Active Low Logic Output. $\overline{\text{RESET}}$ remains low while V _{CC} is below the reset threshold and remains low for 240 ms (typ) after V _{CC} rises above the reset threshold.
2	RESET (ADM810)	Active High Logic Output. RESET remains high while V _{CC} is below the reset threshold and remains high for 240 ms (typ) after V _{CC} rises above the reset threshold.
3	V _{CC}	Supply Voltage Being Monitored

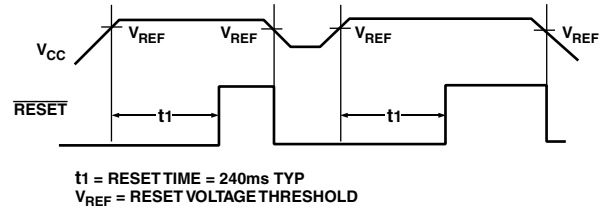

Figure 2. Power Fail Reset Timing

CAUTION

ESD (electrostatic discharge) sensitive device. Electrostatic charges as high as 4000 V readily accumulate on the human body and test equipment and can discharge without detection. Although the ADM809/ADM810 features proprietary ESD protection circuitry, permanent damage may occur on devices subjected to high energy electrostatic discharges. Therefore, proper ESD precautions are recommended to avoid performance degradation or loss of functionality.



ADM809/ADM810

ORDERING GUIDE

Model	Reset Threshold (V)	Temperature Range	Brand Info	Quantity	Package Type
ADM809LART-REEL	4.63	-40°C to +125°C	9LXX	10 k	3-Lead SOT-23
ADM809LART-REEL-7	4.63	-40°C to +125°C	9LXX	3 k	3-Lead SOT-23
ADM809LAKS-REEL	4.63	-40°C to +125°C	M9A	10 k	3-Lead SC70
ADM809LAKS-REEL-7	4.63	-40°C to +125°C	M9A	3 k	3-Lead SC70
ADM809MART-REEL	4.38	-40°C to +125°C	9MXX	10 k	3-Lead SOT-23
ADM809MART-REEL-7	4.38	-40°C to +125°C	9MXX	3 k	3-Lead SOT-23
ADM809MAKS-REEL	4.38	-40°C to +125°C	M9B	10 k	3-Lead SC70
ADM809MAKS-REEL-7	4.38	-40°C to +125°C	M9B	3 k	3-Lead SC70
ADM809JART-REEL	4.00	-40°C to +125°C	9JXX	10 k	3-Lead SOT-23
ADM809JART-REEL-7	4.00	-40°C to +125°C	9JXX	3 k	3-Lead SOT-23
ADM809JAKS-REEL	4.00	-40°C to +125°C	M9C	10 k	3-Lead SC70
ADM809JAKS-REEL-7	4.00	-40°C to +125°C	M9C	3 k	3-Lead SC70
ADM809TART-REEL	3.08	-40°C to +125°C	9TXX	10 k	3-Lead SOT-23
ADM809TART-REEL-7	3.08	-40°C to +125°C	9TXX	3 k	3-Lead SOT-23
ADM809TAKS-REEL	3.08	-40°C to +125°C	M9D	10 k	3-Lead SC70
ADM809TAKS-REEL-7	3.08	-40°C to +125°C	M9D	3 k	3-Lead SC70
ADM809SART-REEL	2.93	-40°C to +125°C	9SXX	10 k	3-Lead SOT-23
ADM809SART-REEL-7	2.93	-40°C to +125°C	9SXX	3 k	3-Lead SOT-23
ADM809SAKS-REEL	2.93	-40°C to +125°C	M9E	10 k	3-Lead SC70
ADM809SAKS-REEL-7	2.93	-40°C to +125°C	M9E	3 k	3-Lead SC70
ADM809RART-REEL	2.63	-40°C to +125°C	9RXX	10 k	3-Lead SOT-23
ADM809RART-REEL-7	2.63	-40°C to +125°C	9RXX	3 k	3-Lead SOT-23
ADM809RAKS-REEL	2.63	-40°C to +125°C	M9F	10 k	3-Lead SC70
ADM809RAKS-REEL-7	2.63	-40°C to +125°C	M9F	3 k	3-Lead SC70
ADM809ZART-REEL	2.32	-40°C to +125°C	9ZXX	10 k	3-Lead SOT-23
ADM809ZART-REEL-7	2.32	-40°C to +125°C	9ZXX	3 k	3-Lead SOT-23
ADM809ZAKS-REEL	2.32	-40°C to +125°C	M9G	10 k	3-Lead SC-70
ADM809ZAKS-REEL-7	2.32	-40°C to +125°C	M9G	3 k	3-Lead SC-70
ADM810LART-REEL	4.63	-40°C to +125°C	9LXX	10 k	3-Lead SOT-23
ADM810LART-REEL-7	4.63	-40°C to +125°C	9LXX	3 k	3-Lead SOT-23
ADM810LAKS-REEL	4.63	-40°C to +125°C	MAA	10 k	3-Lead SC70
ADM810LAKS-REEL-7	4.63	-40°C to +125°C	MAA	3 k	3-Lead SC70
ADM810MART-REEL	4.38	-40°C to +125°C	9MXX	10 k	3-Lead SOT-23
ADM810MART-REEL-7	4.38	-40°C to +125°C	9MXX	3 k	3-Lead SOT-23
ADM810MAKS-REEL	4.38	-40°C to +125°C	MAB	10 k	3-Lead SC70
ADM810MAKS-REEL-7	4.38	-40°C to +125°C	MAB	3 k	3-Lead SC70
ADM810JART-REEL	4.00	-40°C to +125°C	9JXX	10 k	3-Lead SOT-23
ADM810JART-REEL-7	4.00	-40°C to +125°C	9JXX	3 k	3-Lead SOT-23
ADM810JAKS-REEL	4.00	-40°C to +125°C	MAC	10 k	3-Lead SC70
ADM810JAKS-REEL-7	4.00	-40°C to +125°C	MAC	3 k	3-Lead SC70
ADM810TART-REEL	3.08	-40°C to +125°C	9TXX	10 k	3-Lead SOT-23
ADM810TART-REEL-7	3.08	-40°C to +125°C	9TXX	3 k	3-Lead SOT-23
ADM810TAKS-REEL	3.08	-40°C to +125°C	MAD	10 k	3-Lead SC70
ADM810TAKS-REEL-7	3.08	-40°C to +125°C	MAD	3 k	3-Lead SC70
ADM810SART-REEL	2.93	-40°C to +125°C	9SXX	10 k	3-Lead SOT-23
ADM810SART-REEL-7	2.93	-40°C to +125°C	9SXX	3 k	3-Lead SOT-23
ADM810SAKS-REEL	2.93	-40°C to +125°C	MAE	10 k	3-Lead SC70
ADM810SAKS-REEL-7	2.93	-40°C to +125°C	MAE	3 k	3-Lead SC70
ADM810RART-REEL	2.63	-40°C to +125°C	9RXX	10 k	3-Lead SOT-23
ADM810RART-REEL-7	2.63	-40°C to +125°C	9RXX	3 k	3-Lead SOT-23
ADM810RAKS-REEL	2.63	-40°C to +125°C	MAF	10 k	3-Lead SC70
ADM810RAKS-REEL-7	2.63	-40°C to +125°C	MAF	3 k	3-Lead SC70
ADM810ZART-REEL	2.32	-40°C to +125°C	9ZXX	10 k	3-Lead SOT-23
ADM810ZART-REEL-7	2.32	-40°C to +125°C	9ZXX	3 k	3-Lead SOT-23
ADM810ZAKS-REEL	2.32	-40°C to +125°C	MAG	10 k	3-Lead SC70
ADM810ZAKS-REEL-7	2.32	-40°C to +125°C	MAG	3 k	3-Lead SC70

Typical Performance Characteristics—ADM809/ADM810

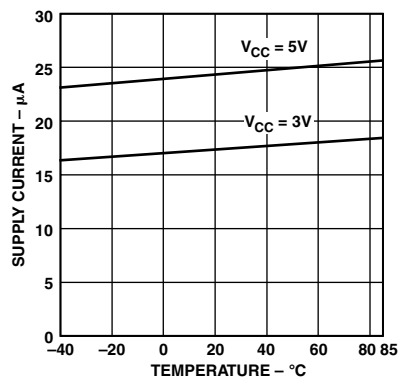

TPC 1. Supply Current vs. Temperature (No Load)

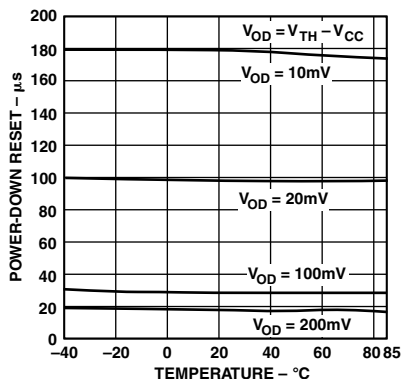

TPC 2. Power-Down RESET Delay vs. Temperature ADM8_L/M/J

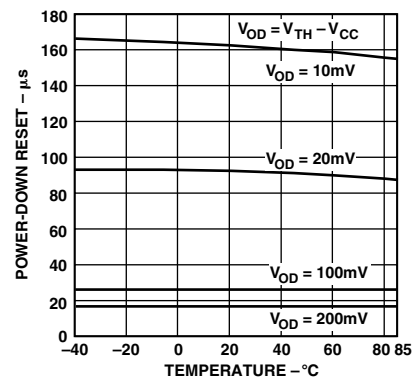

TPC 3. Power-Down RESET Delay vs. Temperature ADM8_T/S/R/Z

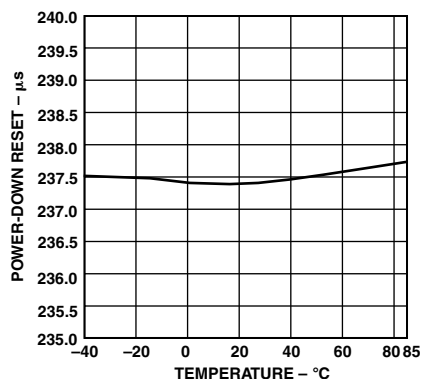

TPC 4. Power-Down RESET Delay vs. Temperature ADM8_R

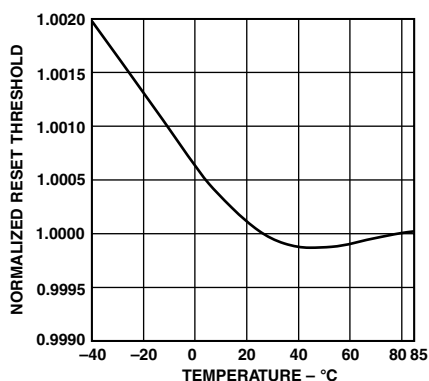

TPC 5. Normalized RESET Voltage Threshold vs. Temperature

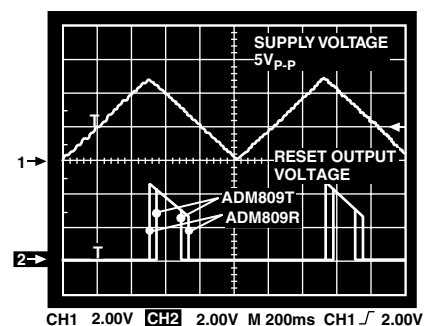

TPC 6. RESET Output Voltage vs. Supply Voltage

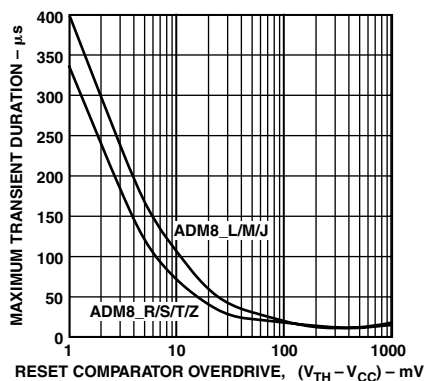

TPC 7. Maximum Transient Duration without Causing a RESET Pulse vs. RESET Comparator Overdrive

ADM809/ADM810

INTERFACING TO OTHER DEVICES OUTPUT

The ADM809/ADM810 series is designed to integrate with as many devices as possible and therefore has a standard output dependent on V_{CC} . This enables the part to be used in both 3 V and 5 V or any nominal voltage within the minimum and maximum specifications for V_{CC} . Because of this design approach, interfacing this device to other devices is simplified.

Ensuring a Valid Reset Output Down to $V_{CC} = 0$ V

When V_{CC} falls below 0.8 V, the ADM809's $\overline{\text{RESET}}$ no longer sinks current. A high impedance CMOS logic input connected to $\overline{\text{RESET}}$ may therefore drift to undetermined logic levels. To eliminate this problem, a 100 k Ω resistor should be connected from $\overline{\text{RESET}}$ to ground.

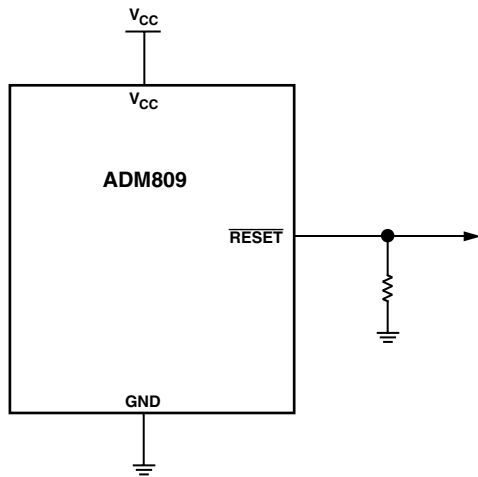

Figure 3. Ensuring a Valid RESET Output Down to $V_{CC} = 0$ V

Benefits of a Very Accurate Reset Threshold

In other microprocessor supervisory circuits, tolerances in supply voltages lead to an overall increase in RESET tolerance levels due to the deterioration of the microprocessor RESET circuit's power supply. The possibility of a malfunction during a power failure is greatly reduced because the ADM809 and ADM810 series can operate effectively even when there are large degradations of the supply voltages. Another advantage of the ADM809 and ADM810 series is its very accurate internal voltage reference circuit. These benefits combine to produce an exceptionally reliable voltage monitor circuit.

Interfacing to Microprocessors with Multiple Interrupts

In a number of cases it is necessary to interface many interrupts from different devices (e.g., thermal, attitude, and velocity sensors). The ADM809 and ADM810 can easily be integrated into existing interrupt-handling circuits (Figure 4) or be used as a standalone device.

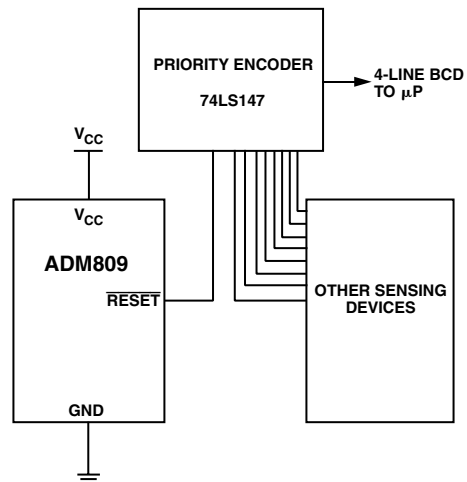
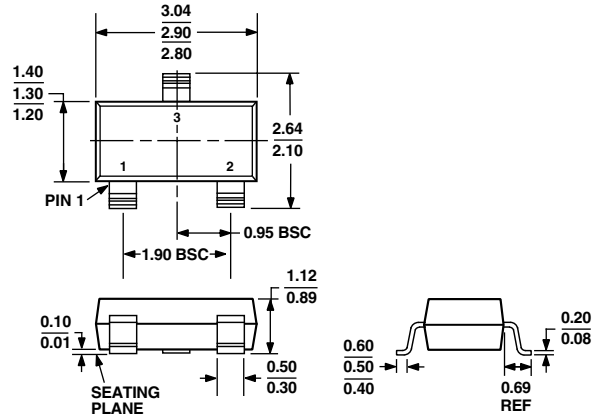

Figure 4. Interfacing to Microprocessors with Multiple Interrupts

OUTLINE DIMENSIONS

3-Lead Plastic Surface-Mount Package [SOT-23]
(RT-3)

Dimensions shown in millimeters



3-Lead Plastic Surface-Mount Package [SC70]
(KS-3)

Dimensions shown in millimeters

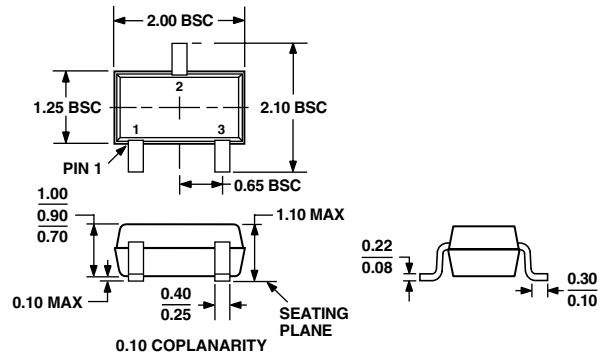

ADM809/ADM810

Revision History

Location	Page
1/03—Data Sheet changed from REV. A to REV. B.	
Changes to SPECIFICATIONS	2
Changes to Table I	3
Changes to ORDERING GUIDE	4
Changes to TPCs 1–3, and TPC 7	5
Updated OUTLINE DIMENSIONS	7
10/02—Data Sheet changed from REV. 0 to REV. A.	
Addition of SC70 package	Universal
Change to GENERAL DESCRIPTION	1
Changes to SPECIFICATIONS	2
Changes to ABSOLUTE MAXIMUM RATINGS	3
Change to Table I	3
Change to ORDERING GUIDE	4
Change to TPC 1	5
Updated OUTLINE DIMENSIONS	7

C00091-0-1/03(B)

PRINTED IN U.S.A.