

PC POWER SUPPLY SUPERVISORS

DESCRIPTION

The UTC 3511 provides protection circuits, power good output (PGO), fault protection latch (FPL_N), and protection detector function (PDON_N) control.

It can minimize external components of switching power supply systems in personal computer.

The Over Voltage Detector (OVD) monitors 3.3V, 5V, 12V input voltage level. The Under Voltage Detector (UVD) monitors 3.3V, 5V input voltage level. When OVD or UVD detect the fault voltage level, the FPL_N is latched HIGH and PGO goes LOW. The latch can be reset by PDON_N going HIGH. There is 2.4ms delay time for PDON_N turning off FPL_N.

When OVD and UVD detect the right voltage level, the power good output (PGO) will be issue.

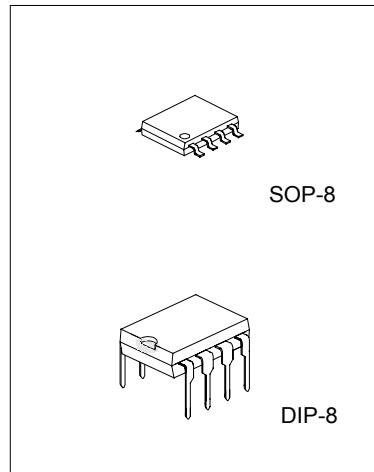

FEATURES

- * The Over Voltage Detector (OVD) monitors 3.3V, 5V, 12V input voltage level.
- * The Under Voltage Detector (UVD) monitors 3.3V, 5V input voltage level.
- * Both of the power good output (PGO) and the fault protection latch (FPL_N) are Open Drain Output.
- * 75 ms time delay for UVD.
- * 300 ms time delay for PGO.
- * 38 ms for PDON_N input signal De-bounce.
- * 73 us for internal signal De-glitches.
- * 2.4 ms time delay for PDON_N turn-off FPL_N.

PIN CONFIGURATION

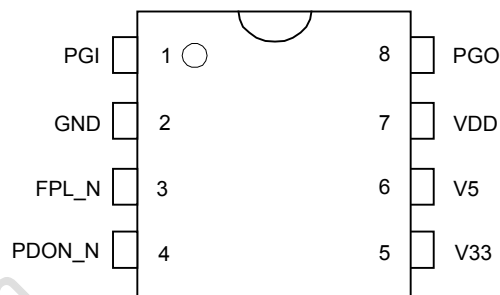

RECOMMENDED OPERATING CONDITIONS

PARAMETER	SYMBOL	MIN	TYP	MAX	UNIT
Supply Voltage	V _{DD}	3.8	12	15	V
Input Voltage	PDON_N,V5,V33,PGI	V _{in}		7	V
Output Voltage	FPL_N	V _{OUT}		15	V
	PGO			7	V
Output Sink Current	FPL_N	I _{osink}		30	mA
	PGO			10	mA
Supply Voltage Rising Time	Trs	1			ms

ELECTRICAL CHARACTERISTICS (Ta=25°C, V_{DD}=5V)

Over Voltage Detection

PARAMETER	SYMBOL	TEST CONDITIONS	MIN	TYP.	MAX	UNIT
Over voltage threshold	V33		3.7	3.9	4.1	V
	V5		5.7	6.1	6.5	
	V _{DD} / V12		12.8	13.4	13.9	
Leakage current (FPL_N)	I _{LEAKAGE}	FPL_N=5V		5		uA
Low level output voltage (FPL_N)	V _{OL}	I _{sink} =10mA		0.3		V
		I _{sink} =30mA		0.7		

PGI and PGO

PARAMETER	SYMBOL	TEST CONDITIONS	MIN	TYP.	MAX	UNIT
Under voltage threshold	V33		2.55	2.69	2.83	V
	V5		4.1	4.3	4.47	
Input threshold voltage (PGI)	V _{PGI}		1.16	1.20	1.24	
Leakage current (PGO)	I _{LEAKAGE}	PGO=5V		5		uA
Low level output voltage (PGO)	V _{OL}	I _{sink} =10mA		0.4		V

PDON_N

PARAMETER	SYMBOL	TEST CONDITIONS	MIN	TYP.	MAX	UNIT
Input pull-up current	I _I	PDON_N=0V		150		uA
High-level input voltage	V _{IH}		2.4			V
Low-level input voltage	V _{IL}				1.2	V

TOTAL DEVICE

PARAMETER	SYMBOL	TEST CONDITIONS	MIN	TYP.	MAX	UNIT
Supply current	I _{CC}	PDON_N=5V			1	mA
low voltage	V _{DD}			3		V

SWITCHING CHARACTERISTICS, VDD=5V

PARAMETER	SYMBOL	TEST CONDITIONS	MIN	TYP.	MAX	UNIT
De-bounce time (PDON_N)	t _{db1}		32	38	61	ms
Delay time (PGI to PGO)	t _{delay}	T _a =-40°C ~ 125°C	200	300	490	ms
De-bounce time (PDON_N)	t _{db2}		32	38	61	ms
De-glitch time	t _g		63	73	120	us
PDON_N to FPL_N delay time	t _{delay2}		T _{db2} +2.0	T _{db2} +2.4	T _{db2} +3.8	ms
Internal UVD delay time	t _{delay3}	FPL_N go low & every Time PGI>1.2V	65	75	122	ms

APPLICATION CIRCUIT

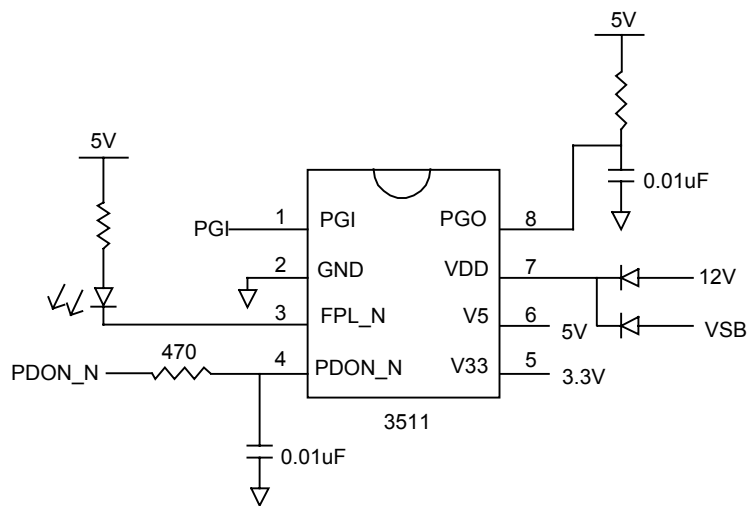

APPLICATION TIMMING

1. PGI (UNDER_VOLTAGE):

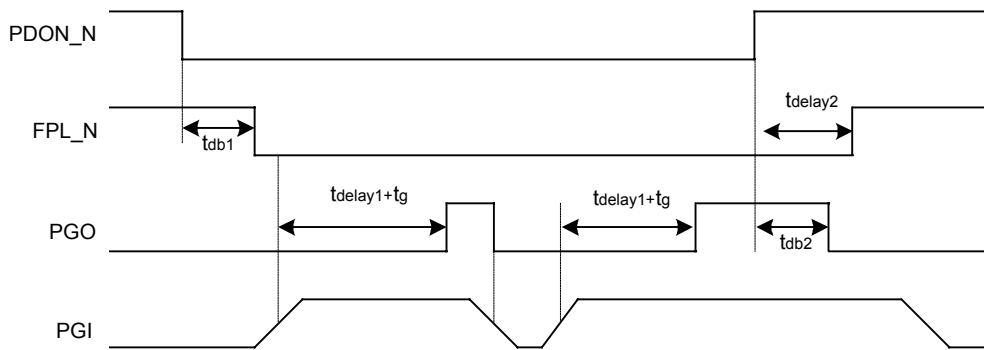
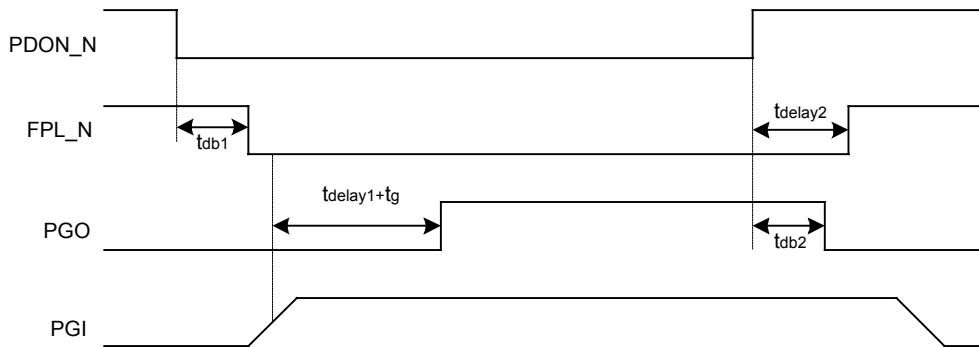

2. V33,V5 (UNDER_VOLTAGE):

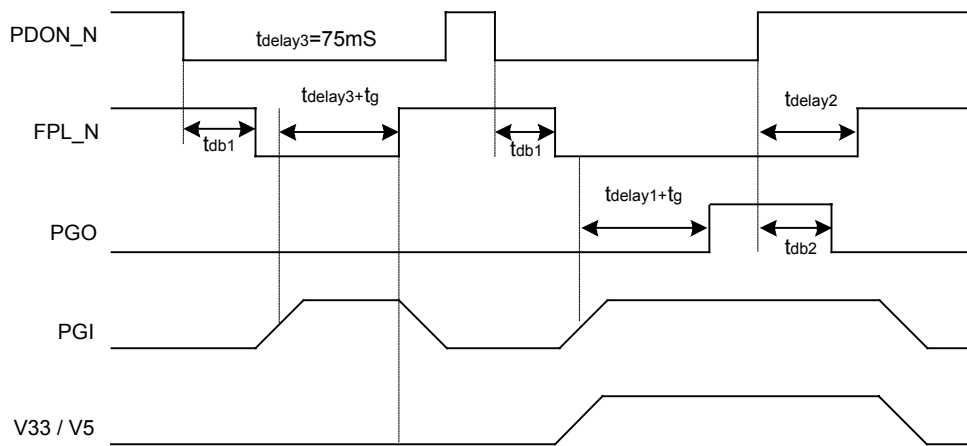
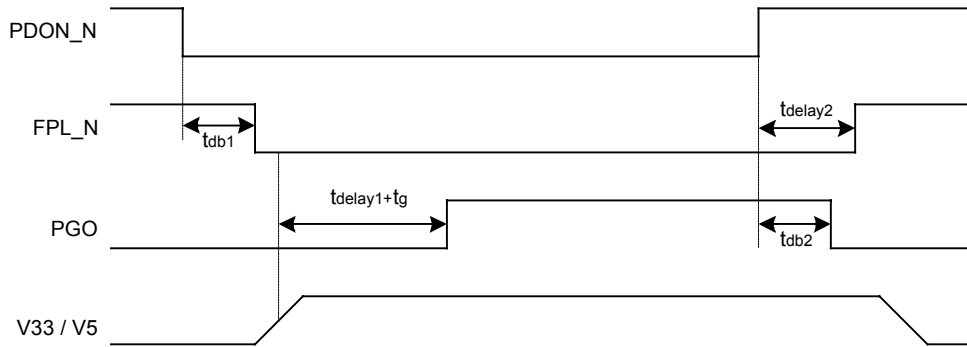

3. V33,V5,V12 (OVER_VOLTAGE):

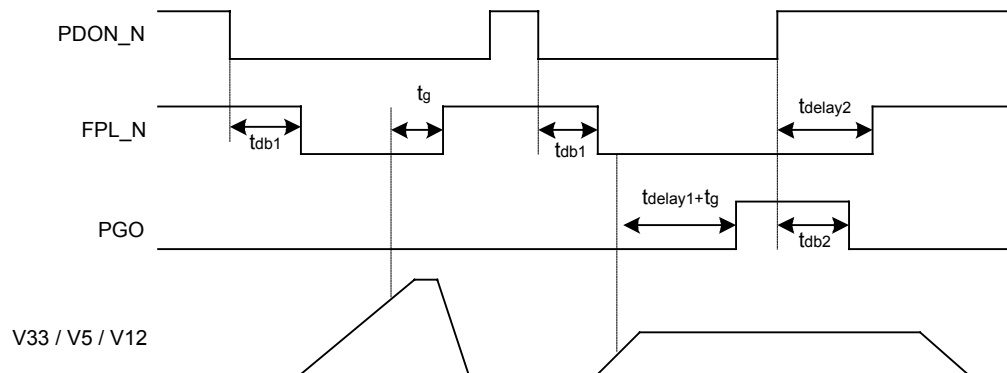
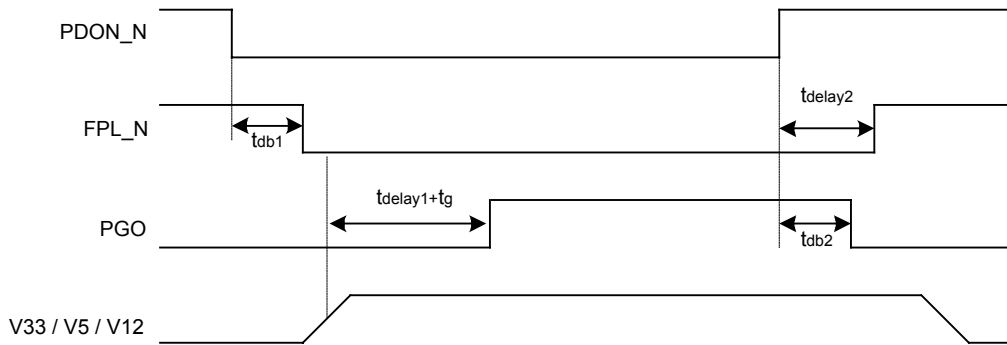

UTC assumes no responsibility for equipment failures that result from using products at values that exceed, even momentarily, rated values (such as maximum ratings, operating condition ranges, or other parameters) listed in products specifications of any and all UTC products described or contained herein. UTC products are not designed for use in life support appliances, devices or systems where malfunction of these products can be reasonably expected to result in personal injury. Reproduction in whole or in part is prohibited without the prior written consent of the copyright owner. The information presented in this document does not form part of any quotation or contract, is believed to be accurate and reliable and may be changed without notice.