

TENTATIVE

TOSHIBA MOS DIGITAL INTEGRATED CIRCUIT SILICON GATE CMOS

## 16-MBIT (2M × 8 BITS / 1M × 16 BITS) CMOS FLASH MEMORY

### DESCRIPTION

The TC58FVT160/B160 is a 16,777,216-bit, 3.0-V read-only electrically erasable and programmable flash memory organized as 2,097,152 words × 8 bits or as 1,048,576 words × 16 bits. The TC58FVT160/B160 features commands for Read, Program and Erase operations to allow easy interfacing with microprocessors. The commands are based on the JEDEC standard. The Program and Erase operations are automatically executed in the chip. The device has Chip, Block and Multi-Block Erase capability.

The TC58FVT160/B160 is available in either a 48-pin TSOP package to suit a variety of design applications.

### FEATURES

- Power Supply  
V<sub>DD</sub> = 2.7 V to 3.6 V
- Organization  
2M × 8 bits / 1M × 16 bits
- Modes  
Auto Program, Auto Chip Erase  
Auto Block Erase, Auto Multiple Block Erase  
Erase Suspend/Resume, Block Protection  
Data Polling/Toggle Bit
- Block Erase Architecture  
1 × 16 Kbytes / 2 × 8 Kbytes /  
1 × 32 Kbytes / 31 × 64 Kbytes
- Boot Block Architecture  
TC58FVT160FT ----- Top Boot Block  
TC58FVB160FT ----- Bottom Boot Block
- Mode Control  
Compatible with JEDEC standard commands
- Erase / Program Cycles  
10<sup>5</sup> Cycles typ.
- Access Time  
85 ns (V<sub>DD</sub> = 3.0 V to 3.6 V)  
100 ns / 120 ns (V<sub>DD</sub> = 2.7 V to 3.6 V)
- Power Dissipation  
250 μA (Standby TTL level)  
5 μA (Standby CMOS level)  
30 mA (Read operation)  
40 mA (Program / Erase Operations)
- Package  
TC58FVT160FT/B160FT : TSOP I 48 - P - 1220 - 0.50  
(Weight: 0.53 g typ.)

### PIN ASSIGNMENT (TOP VIEW)

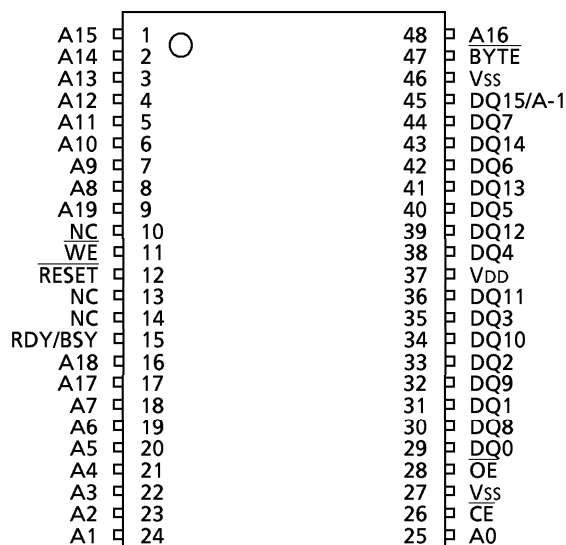

TC58FVT160FT / B160FT (TSOP)

### PIN NAMES

A0 to A19	Address Input
DQ0 to DQ14	Data Input / Output
DQ15/A-1	Output (Input) / Address Input
CE	Chip Enable Input
OE	Output Enable Input
BYTE	Word/Byte Select Input
WE	Write Enable Input
RDY/BSY	Ready/Busy Output
RESET	Hardware Reset Input
NC	No Connection
V <sub>DD</sub>	Power Supply
V <sub>SS</sub>	Ground

000707EBA2

- TOSHIBA is continually working to improve the quality and reliability of its products. Nevertheless, semiconductor devices in general can malfunction or fail due to their inherent electrical sensitivity and vulnerability to physical stress. It is the responsibility of the buyer, when utilizing TOSHIBA products, to comply with the standards of safety in making a safe design for the entire system, and to avoid situations in which a malfunction or failure of such TOSHIBA products could cause loss of human life, bodily injury or damage to property. In developing your designs, please ensure that TOSHIBA products are used within specified operating ranges as set forth in the most recent TOSHIBA products specifications. Also, please keep in mind the precautions and conditions set forth in the "Handling Guide for Semiconductor Devices," or "TOSHIBA Semiconductor Reliability Handbook" etc..
- The TOSHIBA products listed in this document are intended for usage in general electronics applications (computer, personal equipment, office equipment, measuring equipment, industrial robotics, domestic appliances, etc.). These TOSHIBA products are neither intended nor warranted for usage in equipment that requires extraordinarily high quality and/or reliability or a malfunction or failure of which may cause loss of human life or bodily injury ("Unintended Usage"). Unintended Usage include atomic energy control instruments, airplane or spaceship instruments, transportation instruments, traffic signal instruments, combustion control instruments, medical instruments, all types of safety devices, etc.. Unintended Usage of TOSHIBA products listed in this document shall be made at the customer's own risk.
- The products described in this document are subject to the foreign exchange and foreign trade laws.
- The information contained herein is presented only as a guide for the applications of our products. No responsibility is assumed by TOSHIBA CORPORATION for any infringements of intellectual property or other rights of the third parties which may result from its use. No license is granted by implication or otherwise under any intellectual property or other rights of TOSHIBA CORPORATION or others.
- The information contained herein is subject to change without notice.

BLOCK DIAGRAM

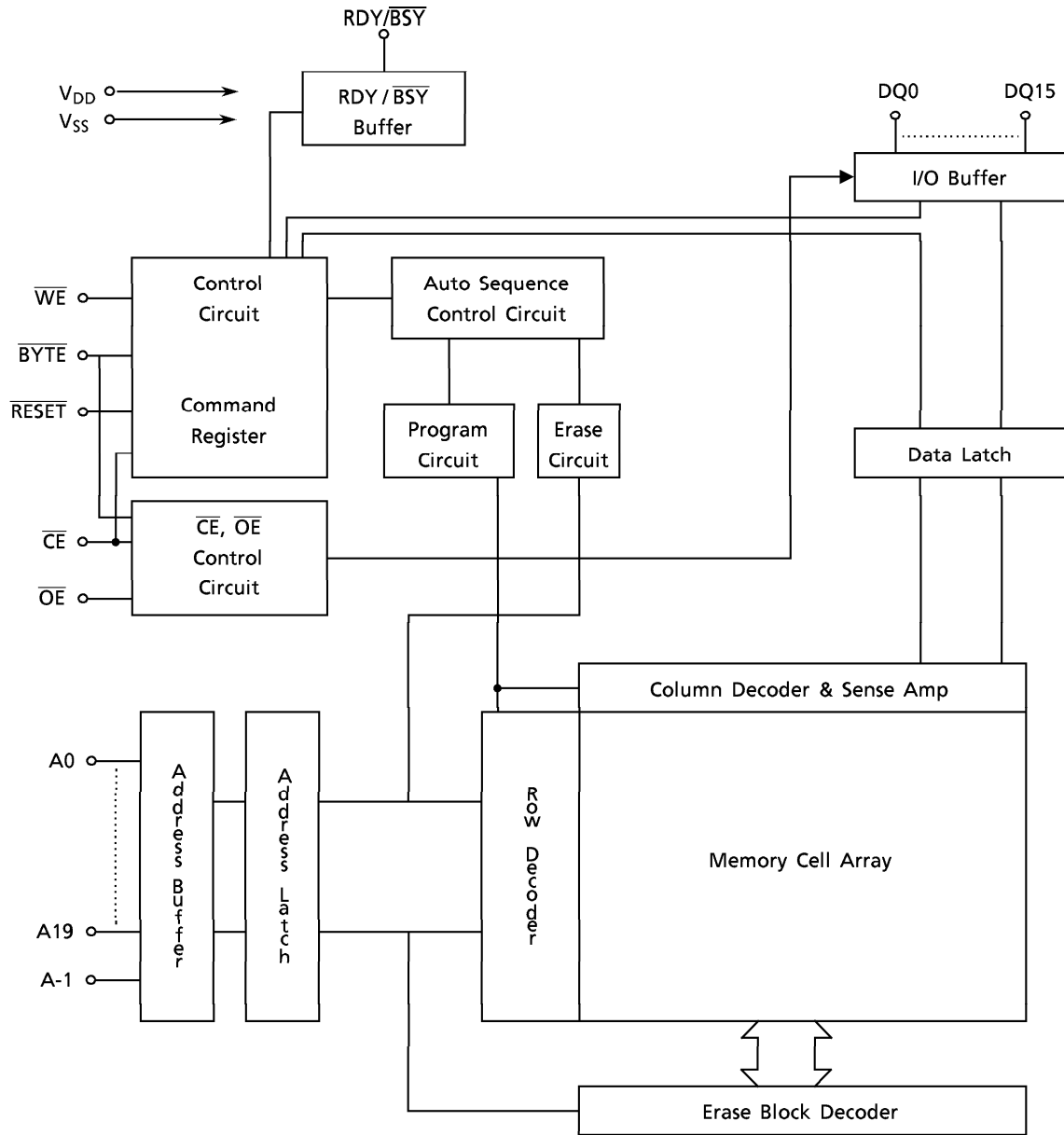

**MODE SELECTION**

MODE	$\overline{CE}$	$\overline{OE}$	$\overline{WE}$	A9	A6	A1	A0	$\overline{RESET}$	BYTE MODE	WORD MODE
									DQ0 to DQ7 <sup>1)</sup>	DQ0 to DQ15
Read	L	L	H	A9	A6	A1	A0	H	Dout	Dout
ID Read (Manufacturer Code)	L	L	H	V <sub>ID</sub>	L	L	L	H	Code	Code
ID Read (Device Code)	L	L	H	V <sub>ID</sub>	L	L	H	H	Code	Code
Standby	H	*	*	*	*	*	*	H	High-Z	High-Z
Output Disable	*	H	H	*	*	*	*	*	High-Z	High-Z
Write	L	H	L	A9	A6	A1	A0	H	Din	Din
Block Protect	L	V <sub>ID</sub>	L	V <sub>ID</sub>	L	H	L	H	*	*
Verify Block Protect	L	L	H	V <sub>ID</sub>	L	H	L	H	Code	Code
Temporary Block Unprotect	*	*	*	*	*	*	*	V <sub>ID</sub>	*	*
Hardware Reset/Standby	*	*	*	*	*	*	*	L	High-Z	High-Z

Notes: \* : V<sub>IH</sub> or V<sub>IL</sub>

1) DQ8 to DQ15 are High-Z in Byte mode.

**ID CODE TABLE**

CODE TYPE		A19 to A12	A6	A1	A0	CODE (HEX) <sup>1)</sup>
Manufacturer Code		*	V <sub>IL</sub>	V <sub>IL</sub>	V <sub>IL</sub>	0098H
Device Code	TC58FVT160	*	V <sub>IL</sub>	V <sub>IL</sub>	V <sub>IH</sub>	00C2H
	TC58FVB160	*	V <sub>IL</sub>	V <sub>IL</sub>	V <sub>IH</sub>	0043H
Verify Block Protect		BA <sup>2)</sup>	V <sub>IL</sub>	V <sub>IH</sub>	V <sub>IL</sub>	Data <sup>3)</sup>

Notes: \* : V<sub>IH</sub> or V<sub>IL</sub>

1) DQ8 to DQ15 are High-Z in Byte mode

2) BA: Block Address

3) 0001H – Protected Block

0000H – Unprotected Block

Address are A19:A0 in word mode ( $\overline{BYTE} = V_{IH}$ ), A19:A-1 in byte mode ( $\overline{BYTE} = V_{IL}$ )

**COMMAND DEFINITIONS**

COMMAND SEQUENCE		BUS WRITE CYCLES REQ'D	FIRST BUS WRITE CYCLE		SECOND BUS WRITE CYCLE		THIRD BUS WRITE CYCLE		FOURTH BUS READ/WRITE CYCLE		FIFTH BUS WRITE CYCLE		SIXTH BUS WRITE CYCLE	
			Addr.	Data	Addr.	Data	Addr.	Data	Addr.	Data	Addr.	Data	Addr.	Data
Read/Reset		1	XXXXH	F0H										
Read/Reset	Word	3	555H	AAH	2AAH	55H	555H	F0H	RA <sup>1)</sup>	RD <sup>2)</sup>				
	Byte		AAAH		555H		AAAH							
ID Read/Verify Block Protect	Word	3	555H	AAH	2AAH	55H	555H	90H	IA <sup>3)</sup>	ID <sup>4)</sup>				
	Byte		AAAH		555H		AAAH							
Auto Program	Word	4	555H	AAH	2AAH	55H	555H	A0H	PA <sup>5)</sup>	PD <sup>6)</sup>				
	Byte		AAAH		555H		AAAH							
Auto Chip Erase	Word	6	555H	AAH	2AAH	55H	555H	80H	555H	AAH	2AAH	55H	555H	10H
	Byte		AAAH		555H		AAAH		AAAH		555H		AAAH	
Auto Block Erase	Word	6	555H	AAH	2AAH	55H	555H	80H	555H	AAH	2AAH	55H	BA <sup>7)</sup>	30H
	Byte		AAAH		555H		AAAH		AAAH		555H			
Block Protect	Word	6	555H	AAH	2AAH	55H	555H	9AH	555H	AAH	2AAH	55H	555H	9AH
	Byte		AAAH		555H		AAAH		AAAH		555H		AAAH	
Block Erase Suspend			Addr: V <sub>IH</sub> or V <sub>IL</sub> , Data: B0H											
Block Erase Resume			Addr: V <sub>IH</sub> or V <sub>IL</sub> , Data: 30H											

Notes: The system should generate the following address patterns:

Word mode: 555H or 2AAH to addresses A10 to A0  
 Byte mode: AAAH or 555H to addresses A10 to A-1

DQ8 to DQ15 are ignored in Word mode.

1) RA : Read Address

2) RD : Read Data

3) IA : ID Address (A6, A1, A0)

00H = Manufacturer Code

01H = Device Code

02H = Verify Block Protect (A19 to A12 = Block Address)

4) ID : ID Data

0098H - Manufacturer Code

00C2H - Device Code (TC58FVT160)

0043H - Device Code (TC58FVB160)

0001H - Protected Block

0000H - Unprotected Block

5) PA : Program Address

6) PD : Program Data

7) BA : Block Address

**HARDWARE STATUS FLAGS**

STATUS		DQ7	DQ6	DQ5	DQ3	RDY/BSY
In Progress	Auto Programming	$\overline{\text{DQ7}}$	Toggle	0	0	0
	Auto Erase (Erase Hold Time)	0	Toggle	0	0	0
	Auto Erase	0	Toggle	0	1	0
Time Limits Exceeded	Auto Programming	$\overline{\text{DQ7}}$	Toggle	1	1	0
	Auto Erase	0	Toggle	1	1	0

Notes: 1. DQ outputs cell data and RDY/BSY outputs 1 when the operation has completed.

2. DQ0, DQ1 and DQ2 pins are reserved for future use.

3. DQ8 to DQ15 : Output 0 or 1 in Word mode.

4. DQ0 to DQ2 and DQ4 : Output 0.

**BLOCK ERASE ADDRESS TABLES**

TC58FVT160 (Top Boot Block)

BLOCK #	A19	A18	A17	A16	A15	A14	A13	A12	BYTE MODE		WORD MODE	
									ADDRESS RANGE	SIZE	ADDRESS RANGE	SIZE
BA0	L	L	L	L	L	*	*	*	000000H - 00FFFFH	64 K bytes	00000H - 07FFFFH	32 K words
BA1	L	L	L	L	H	*	*	*	010000H - 01FFFFH	64 K bytes	08000H - 0FFFFH	32 K words
BA2	L	L	L	H	L	*	*	*	020000H - 02FFFFH	64 K bytes	10000H - 17FFFFH	32 K words
BA3	L	L	L	H	H	*	*	*	030000H - 03FFFFH	64 K bytes	18000H - 1FFFFH	32 K words
BA4	L	L	H	L	L	*	*	*	040000H - 04FFFFH	64 K bytes	20000H - 27FFFFH	32 K words
BA5	L	L	H	L	H	*	*	*	050000H - 05FFFFH	64 K bytes	28000H - 2FFFFH	32 K words
BA6	L	L	H	H	L	*	*	*	060000H - 06FFFFH	64 K bytes	30000H - 37FFFFH	32 K words
BA7	L	L	H	H	H	*	*	*	070000H - 07FFFFH	64 K bytes	38000H - 3FFFFH	32 K words
BA8	L	H	L	L	L	*	*	*	080000H - 08FFFFH	64 K bytes	40000H - 47FFFFH	32 K words
BA9	L	H	L	L	H	*	*	*	090000H - 09FFFFH	64 K bytes	48000H - 4FFFFH	32 K words
BA10	L	H	L	H	L	*	*	*	0A0000H - 0AFFFFH	64 K bytes	50000H - 57FFFFH	32 K words
BA11	L	H	L	H	H	*	*	*	0B0000H - 0BFFFFH	64 K bytes	58000H - 5FFFFH	32 K words
BA12	L	H	H	L	L	*	*	*	0C0000H - 0CFFFFH	64 K bytes	60000H - 67FFFFH	32 K words
BA13	L	H	H	L	H	*	*	*	0D0000H - 0DFFFFH	64 K bytes	68000H - 6FFFFH	32 K words
BA14	L	H	H	H	L	*	*	*	0E0000H - 0EFFFFH	64 K bytes	70000H - 77FFFFH	32 K words
BA15	L	H	H	H	H	*	*	*	0F0000H - 0FFFFFH	64 K bytes	78000H - 7FFFFH	32 K words
BA16	H	L	L	L	L	*	*	*	100000H - 10FFFFH	64 K bytes	80000H - 87FFFFH	32 K words
BA17	H	L	L	L	H	*	*	*	110000H - 11FFFFH	64 K bytes	88000H - 8FFFFH	32 K words
BA18	H	L	L	H	L	*	*	*	120000H - 12FFFFH	64 K bytes	90000H - 97FFFFH	32 K words
BA19	H	L	L	H	H	*	*	*	130000H - 13FFFFH	64 K bytes	98000H - 9FFFFH	32 K words
BA20	H	L	H	L	L	*	*	*	140000H - 14FFFFH	64 K bytes	A0000H - A7FFFFH	32 K words
BA21	H	L	H	L	H	*	*	*	150000H - 15FFFFH	64 K bytes	A8000H - AFFFFH	32 K words
BA22	H	L	H	H	L	*	*	*	160000H - 16FFFFH	64 K bytes	B0000H - B7FFFFH	32 K words
BA23	H	L	H	H	H	*	*	*	170000H - 17FFFFH	64 K bytes	B8000H - BFFFFH	32 K words
BA24	H	H	L	L	L	*	*	*	180000H - 18FFFFH	64 K bytes	C0000H - C7FFFFH	32 K words
BA25	H	H	L	L	H	*	*	*	190000H - 19FFFFH	64 K bytes	C8000H - CFFFFH	32 K words
BA26	H	H	L	H	L	*	*	*	1A0000H - 1AFFFFH	64 K bytes	D0000H - D7FFFFH	32 K words
BA27	H	H	L	H	H	*	*	*	1B0000H - 1BFFFFH	64 K bytes	D8000H - DFFFFH	32 K words
BA28	H	H	H	L	L	*	*	*	1C0000H - 1CFFFFH	64 K bytes	E0000H - E7FFFFH	32 K words
BA29	H	H	H	L	H	*	*	*	1D0000H - 1DFFFFH	64 K bytes	E8000H - EFFFFH	32 K words
BA30	H	H	H	H	L	*	*	*	1E0000H - 1EFFFFH	64 K bytes	F0000H - F7FFFFH	32 K words
BA31	H	H	H	H	H	L	*	*	1F0000H - 1F7FFFH	32 K bytes	F8000H - FBFFFFH	16 K words
BA32	H	H	H	H	H	H	L	L	1F8000H - 1F9FFFH	8 K bytes	FC000H - FCFFFH	4 K words
BA33	H	H	H	H	H	H	L	H	1FA000H - 1FBFFFH	8 K bytes	FD000H - FDFFFH	4 K words
BA34	H	H	H	H	H	H	H	*	1FC000H - 1FFFFFH	16 K bytes	FE000H - FFFFFH	8 K words

TC58FVB160 (Bottom Boot Block)

BLOCK #	A19	A18	A17	A16	A15	A14	A13	A12	BYTE MODE		WORD MODE	
									ADDRESS RANGE	SIZE	ADDRESS RANGE	SIZE
BA0	L	L	L	L	L	L	L	*	000000H - 003FFFH	16 K bytes	00000H - 01FFFH	8 K words
BA1	L	L	L	L	L	L	H	L	004000H - 005FFFH	8 K bytes	02000H - 02FFFH	4 K words
BA2	L	L	L	L	L	L	H	H	006000H - 007FFFH	8 K bytes	03000H - 03FFFH	4 K words
BA3	L	L	L	L	L	H	*	*	008000H - 00FFFFH	32 K bytes	04000H - 07FFFH	16 K words
BA4	L	L	L	L	H	*	*	*	010000H - 01FFFH	64 K bytes	08000H - 0FFFFH	32 K words
BA5	L	L	L	H	L	*	*	*	020000H - 02FFFH	64 K bytes	10000H - 17FFFH	32 K words
BA6	L	L	L	H	H	*	*	*	030000H - 03FFFH	64 K bytes	18000H - 1FFFFH	32 K words
BA7	L	L	H	L	L	*	*	*	040000H - 04FFFH	64 K bytes	20000H - 27FFFH	32 K words
BA8	L	L	H	L	H	*	*	*	050000H - 05FFFH	64 K bytes	28000H - 2FFFFH	32 K words
BA9	L	L	H	H	L	*	*	*	060000H - 06FFFH	64 K bytes	30000H - 37FFFH	32 K words
BA10	L	L	H	H	H	*	*	*	070000H - 07FFFH	64 K bytes	38000H - 3FFFFH	32 K words
BA11	L	H	L	L	L	*	*	*	080000H - 08FFFH	64 K bytes	40000H - 47FFFH	32 K words
BA12	L	H	L	L	H	*	*	*	090000H - 09FFFH	64 K bytes	48000H - 4FFFFH	32 K words
BA13	L	H	L	H	L	*	*	*	0A0000H - 0AFFFH	64 K bytes	50000H - 57FFFH	32 K words
BA14	L	H	L	H	H	*	*	*	0B0000H - 0BFFFH	64 K bytes	58000H - 5FFFFH	32 K words
BA15	L	H	H	L	L	*	*	*	0C0000H - 0CFFFH	64 K bytes	60000H - 67FFFH	32 K words
BA16	L	H	H	L	H	*	*	*	0D0000H - 0DFFFH	64 K bytes	68000H - 6FFFFH	32 K words
BA17	L	H	H	H	L	*	*	*	0E0000H - 0EFFFH	64 K bytes	70000H - 77FFFH	32 K words
BA18	L	H	H	H	H	*	*	*	0F0000H - 0FFFFH	64 K bytes	78000H - 7FFFFH	32 K words
BA19	H	L	L	L	L	*	*	*	100000H - 10FFFH	64 K bytes	80000H - 87FFFH	32 K words
BA20	H	L	L	L	H	*	*	*	110000H - 11FFFH	64 K bytes	88000H - 8FFFFH	32 K words
BA21	H	L	L	H	L	*	*	*	120000H - 12FFFH	64 K bytes	90000 - 97FFFH	32 K words
BA22	H	L	L	H	H	*	*	*	130000H - 13FFFH	64 K bytes	98000H - 9FFFFH	32 K words
BA23	H	L	H	L	L	*	*	*	140000H - 14FFFH	64 K bytes	A0000H - A7FFFH	32 K words
BA24	H	L	H	L	H	*	*	*	150000H - 15FFFH	64 K bytes	A8000H - AFFFFH	32 K words
BA25	H	L	H	H	L	*	*	*	160000H - 16FFFH	64 K bytes	B0000H - B7FFFH	32 K words
BA26	H	L	H	H	H	*	*	*	170000H - 17FFFH	64 K bytes	B8000H - BFFFFH	32 K words
BA27	H	H	L	L	L	*	*	*	180000H - 18FFFH	64 K bytes	C0000H - C7FFFH	32 K words
BA28	H	H	L	L	H	*	*	*	190000H - 19FFFH	64 K bytes	C8000H - CFFFFH	32 K words
BA29	H	H	L	H	L	*	*	*	1A0000H - 1AFFFH	64 K bytes	D0000H - D7FFFH	32 K words
BA30	H	H	L	H	H	*	*	*	1B0000H - 1BFFFH	64 K bytes	D8000H - DFFFFH	32 K words
BA31	H	H	H	L	L	*	*	*	1C0000H - 1CFFFH	64 K bytes	E0000H - E7FFFH	32 K words
BA32	H	H	H	L	H	*	*	*	1D0000H - 1DFFFH	64 K bytes	E8000H - EFFFFH	32 K words
BA33	H	H	H	H	L	*	*	*	1E0000H - 1EFFFH	64 K bytes	F0000H - F7FFFH	32 K words
BA34	H	H	H	H	H	*	*	*	1F0000H - 1FFFFH	64 K bytes	F8000H - FFFFFH	32 K words

The address range is A19 : A-1 in if Byte Mode ( $\overline{\text{BYTE}} = V_{IL}$ )

The address range is A19 : A0 in if Word Mode ( $\overline{\text{BYTE}} = V_{IH}$ )

**ABSOLUTE MAXIMUM RATINGS**

SYMBOL	PARAMETER	RANGE	UNIT
V <sub>DD</sub>	V <sub>DD</sub> Supply Voltage	-0.6 to 4.6	V
V <sub>IN</sub>	Input Voltage	-0.6 to V <sub>DD</sub> + 0.5 (≦ 4.6)	V
V <sub>DQ</sub>	Input/Output Voltage	-0.6 to V <sub>DD</sub> + 0.5 (≦ 4.6)	V
P <sub>D</sub>	Power Dissipation	0.6	W
T <sub>SOLDER</sub>	Soldering Temperature (10 s)	260	°C
T <sub>STG</sub>	Storage Temperature	-55 to 150	°C
T <sub>OPR</sub>	Operating Temperature	-40 to 85	°C
N <sub>EW</sub>	Erase/Program Cycling Capability	100,000	Cycles
V <sub>IDH</sub>	Maximum Input Voltage	13.0	V
I <sub>OSHORT</sub>	Output Short Circuit Current 1)	100	mA

1) Outputs should be shorted for no more than one second.  
No more than one output should be shorted at a time.

**CAPACITANCE (Ta = 25°C, f = 1 MHz)**

SYMBOL	PARAMETER	CONDITION	TYP.	MAX	UNIT
C <sub>IN</sub>	Input Pin Capacitance	V <sub>IN</sub> = 0 V	4	8	pF
C <sub>OUT</sub>	Output Pin Capacitance	V <sub>OUT</sub> = 0 V	10	12	pF
C <sub>IN2</sub>	Control Pin Capacitance	V <sub>IN</sub> = 0 V	8	10	pF

This parameter is periodically sampled and is not tested for every device.

**RECOMMENDED DC OPERATING CONDITIONS (Ta = -40 to 85°C)**

SYMBOL	PARAMETER	MIN	MAX	UNIT
V <sub>DD</sub>	V <sub>DD</sub> Supply Voltage	2.7	3.6	V
V <sub>IH</sub>	Input High Level Voltage	0.7V <sub>DD</sub>	V <sub>DD</sub> + 0.5	
V <sub>IL</sub>	Input Low Level Voltage	-0.3 1)	0.8	
V <sub>ID</sub>	Voltage for ID Read and Block Protect	11.4	12.6	

1) -2 V (pulse width of 20 ns Max)

**DC CHARACTERISTICS** (Ta = -40 to 85°C, V<sub>DD</sub> = 2.7 to 3.6 V)

SYMBOL	PARAMETER	CONDITION	MIN	MAX	UNIT
I <sub>LI</sub>	Input Leakage Current	0 V ≤ V <sub>IN</sub> ≤ V <sub>DD</sub>	-	± 1	μA
I <sub>LO</sub>	Output Leakage Current	0 V ≤ V <sub>OUT</sub> ≤ V <sub>DD</sub>	-	± 1	
V <sub>OH1</sub>	Output High Voltage (TTL)	I <sub>OH</sub> = -0.4 mA	2.4	-	V
V <sub>OH2</sub>	Output High Voltage (CMOS)	I <sub>OH</sub> = -0.1 mA	V <sub>DD</sub> - 0.4	-	
		I <sub>OH</sub> = -2.5 mA	0.85 × V <sub>DD</sub>	-	
V <sub>OL</sub>	Output Low Voltage	I <sub>OL</sub> = 4.0 mA	-	0.4	
I <sub>DDO1</sub>	V <sub>DD</sub> Average Read Current	V <sub>IN</sub> = V <sub>IH</sub> / V <sub>IL</sub> , I <sub>OUT</sub> = 0 mA CYCLE = t <sub>RC</sub> (min)	-	30	mA
I <sub>DDO2</sub>	V <sub>DD</sub> Average Program Current	V <sub>IN</sub> = V <sub>IH</sub> / V <sub>IL</sub> , I <sub>OUT</sub> = 0 mA	-	40	
I <sub>DDO3</sub>	V <sub>DD</sub> Average Erase Current	V <sub>IN</sub> = V <sub>IH</sub> / V <sub>IL</sub> , I <sub>OUT</sub> = 0 mA	-	40	
I <sub>DDS1</sub>	V <sub>DD</sub> Standby Current (TTL)	$\overline{CE} = \overline{RESET} = V_{IH}$ or $\overline{RESET} = V_{IL}$	-	250	μA
I <sub>DDS2</sub>	V <sub>DD</sub> Standby Current (CMOS)	$\overline{CE} = \overline{RESET} = V_{DD} \pm 0.2 V$ or $\overline{RESET} = V_{SS} \pm 0.2 V$	-	5	
I <sub>ID</sub>	High Voltage Input Current	11.4 V ≤ V <sub>ID</sub> ≤ 12.6	-	200	
V <sub>LKO</sub>	Low V <sub>DD</sub> Lock-out Voltage	-	-	2.5	V

**AC TEST CONDITIONS**

PARAMETER	CONDITION
Input Pulse Level	2.4 V / 0.4 V
Input Pulse Rise and Fall Time (10% to 90%)	5 ns
Timing Measurement Reference Level (Input)	1.5 V / 1.5 V
Timing Measurement Reference Level (Output)	1.5 V / 1.5 V
Output Load	C <sub>L</sub> (100 pF) + 1 TTL Gate



**AC CHARACTERISTICS AND OPERATING CONDITIONS**

SYMBOL	PARAMETER	-85		-10		-12		UNIT
		Ta = -40 to 85 °C						
		V <sub>DD</sub> = 3.0 to 3.6 V		V <sub>DD</sub> = 2.7 to 3.6 V				
		MIN	MAX	MIN	MAX	MIN	MAX	
t <sub>RC</sub>	Read Cycle Time	85	-	100	-	120	-	ns
t <sub>ACC</sub>	Address Access Time	-	85	-	100	-	120	ns
t <sub>CE</sub>	$\overline{CE}$ Access Time	-	85	-	100	-	120	ns
t <sub>OE</sub>	$\overline{OE}$ Access Time	-	35	-	40	-	50	ns
t <sub>CEE</sub>	$\overline{CE}$ to Output Low-Z	0	-	0	-	0	-	ns
t <sub>OEE</sub>	$\overline{OE}$ to Output Low-Z	0	-	0	-	0	-	ns
t <sub>OEH</sub>	$\overline{OE}$ Hold Time (Read)	0	-	0	-	0	-	ns
t <sub>OH</sub>	Output Data Hold Time	0	-	0	-	0	-	ns
t <sub>DF1</sub>	$\overline{CE}$ to Output High-Z	-	30	-	30	-	30	ns
t <sub>DF2</sub>	$\overline{OE}$ to Output High-Z	-	30	-	30	-	30	ns
t <sub>CMD</sub>	Command Write Cycle Time	85	-	100	-	120	-	ns
t <sub>AS</sub>	Address Setup Time	0	-	0	-	0	-	ns
t <sub>AH</sub>	Address Hold Time	45	-	50	-	50	-	ns
t <sub>DS</sub>	Data Setup Time	45	-	50	-	60	-	ns
t <sub>DH</sub>	Data Hold Time	0	-	0	-	0	-	ns
t <sub>WELH</sub>	$\overline{WE}$ Low Level Hold Time ( $\overline{WE}$ Control)	45	-	50	-	50	-	ns
t <sub>WEHH</sub>	$\overline{WE}$ High Level Hold Time ( $\overline{WE}$ Control)	20	-	20	-	20	-	ns
t <sub>CES</sub>	$\overline{CE}$ Setup Time to $\overline{WE}$ Active ( $\overline{WE}$ Control)	0	-	0	-	0	-	ns
t <sub>CEH</sub>	$\overline{CE}$ Hold Time from $\overline{WE}$ High Level ( $\overline{WE}$ Control)	0	-	0	-	0	-	ns
t <sub>CELH</sub>	$\overline{CE}$ Low Level Hold Time ( $\overline{CE}$ Control)	45	-	50	-	50	-	ns
t <sub>CEHH</sub>	$\overline{CE}$ High Level Hold Time ( $\overline{CE}$ Control)	20	-	20	-	20	-	ns
t <sub>WES</sub>	$\overline{WE}$ Setup Time to $\overline{CE}$ Active ( $\overline{CE}$ Control)	0	-	0	-	0	-	ns
t <sub>WEH</sub>	$\overline{WE}$ Hold Time from High Level ( $\overline{CE}$ Control)	0	-	0	-	0	-	ns
t <sub>OES</sub>	$\overline{OE}$ Setup to $\overline{WE}$ Active	0	-	0	-	0	-	ns
t <sub>OEHP</sub>	$\overline{OE}$ Hold Time (Toggle/Data Polling)	10	-	10	-	10	-	ns
t <sub>OEHT</sub>	$\overline{OE}$ High Level Hold Time (Toggle)	20	-	20	-	20	-	ns
t <sub>PPW</sub>	Auto Program Time	16 *	3600	16 *	3600	16 *	3600	μs
t <sub>PCEW</sub>	Auto Chip Erase Time	50 *	-	50 *	-	50 *	-	s
t <sub>PBEW</sub>	Auto Block Erase Time	1.5 *	15	1.5 *	15	1.5 *	15	s
t <sub>VDS</sub>	V <sub>DD</sub> Setup Time	500	-	500	-	500	-	μs
t <sub>BUSY</sub>	Program/Erase Valid to RDY/ $\overline{BSY}$ Delay	35	-	40	-	50	-	ns
t <sub>RP</sub>	$\overline{RESET}$ Low Level Hold Time	500	-	500	-	500	-	ns
t <sub>READY</sub>	$\overline{RESET}$ Low Level to Read Mode	-	20	-	20	-	20	μs
t <sub>RB</sub>	RDY/ $\overline{BSY}$ Recovery Time	0	-	0	-	0	-	ns
t <sub>RH</sub>	$\overline{RESET}$ Recovery Time	500	-	500	-	500	-	ns
t <sub>CEBTS</sub>	$\overline{CE}$ Setup time BYTE Transition	5	-	5	-	5	-	ns
t <sub>BTD</sub>	BYTE to Output High-Z	-	30	-	30	-	30	ns
t <sub>VPT</sub>	V <sub>ID</sub> Transition Time	4	-	4	-	4	-	μs
t <sub>VPS</sub>	V <sub>ID</sub> Setup Time	4	-	4	-	4	-	μs
t <sub>VPH</sub>	$\overline{OE}$ Hold Time (Block Protect)	8	-	8	-	8	-	μs
t <sub>PP LH</sub>	$\overline{WE}$ Low Level Hold Time (Block Protect)	100	-	100	-	100	-	μs
t <sub>PAS</sub>	Protect Address Setup Time	0	-	0	-	0	-	ns
t <sub>PAH</sub>	Protect Address Hold Time	0	-	0	-	0	-	ns
t <sub>CESP</sub>	$\overline{CE}$ Setup Time (Block Protect)	4	-	4	-	4	-	μs
t <sub>CEHP</sub>	$\overline{CE}$ Hold Time (Block Protect)	8	-	8	-	8	-	μs
t <sub>SUS</sub>	Suspend Command to Suspend Mode	-	15	-	15	-	15	μs
t <sub>RES</sub>	Resume Command to Erase Mode	-	1	-	1	-	1	μs

\* : Typ.

## OPERATING MODES

### READ MODE

When the device is set to Read mode, it acts as an asynchronous ROM with an access time of 85/100/120 ns. The device is set to Read mode at power-on or when an Auto - Program / Erase operation completes. A software or hardware reset is necessary to return the device to Read mode when an Auto Program / Erase operation fails.

### STANDBY MODE

There are two methods of entering Standby mode: the first involves using both  $\overline{CE}$  and  $\overline{RESET}$  and the second using only  $\overline{RESET}$ .

The first method involves using  $\overline{CE}$  and  $\overline{RESET}$  for mode control. If  $V_{DD} \pm 0.2$  V (CMOS level) is applied to  $\overline{CE}$  and  $\overline{RESET}$  when the device is operating in Read mode, the current is reduced below 5  $\mu$ A. Similarly, if  $V_{IH}$  (TTL level) is applied to  $\overline{CE}$  and  $\overline{RESET}$ , the current is reduced below 250  $\mu$ A. When using  $\overline{CE}$  for control, make sure that the device is operating in Read mode; otherwise, it is not possible to enter Standby mode.

The second method involves using only  $\overline{RESET}$  for mode control. If  $V_{SS} \pm 0.2$  V (CMOS level) is applied to  $\overline{RESET}$  when the device is operating in Read mode, the current is reduced below 5  $\mu$ A. Similarly, if  $V_{IL}$  (TTL level) is applied to  $\overline{RESET}$ , the current is reduced below 250  $\mu$ A. The difference the control method using  $\overline{CE}$  described above, is that if  $V_{IL}$  is applied to  $\overline{RESET}$  when the device is operating in any mode other than Read mode, it enters Standby mode after stopping the operating which is currently being executed. This is a hardware reset and is described later.

In standby mode, DQ is put in high-impedance state.

### COMMAND WRITE

The TC58FVT160/B160 utilizes the JEDEC command control standard for a single power supply E<sup>2</sup>PROM. A command is executed by inputting an address and data into the Command register. The command is entered by a  $\overline{WE}$  Control Write ( $\overline{WE}$  pulse with  $\overline{CE} = V_{IL}$  and  $\overline{OE} = V_{IH}$ ) or a  $\overline{CE}$  Control Write ( $\overline{CE}$  pulse with  $\overline{WE} = V_{IL}$  and  $\overline{OE} = V_{IH}$ ). The address is latched on the falling edge of either  $\overline{WE}$  or  $\overline{CE}$ . The data is latched on the rising edge of either  $\overline{WE}$  or  $\overline{CE}$ . DQ0 to 7 are valid for data input and DQ8 to 15 are ignored.

A command is when the Reset command is input. The device then enters Read Mode. When an undefined command is input, the Command register is reset and the device enters Read mode.

### RESET (Software Reset)

The device does not enter Read mode automatically when a command such as Auto Program / Erase or ID Read is not correctly executed (for example, if Program or Erase fails). The Reset or Read Command is necessary to return the device to Read mode. The Reset and Read commands must also be used to reset the Command register.

### RESET (Hardware Reset)

A hardware reset is used for aborting Auto mode operations such as Auto Program/Erase and for resetting the operation mode. The device enters Read mode 20  $\mu$ s after a 500-ns Low level input pulse to the  $\overline{RESET}$  pin. Data may be corrupted if the device is reset during an Auto mode operation.

After a hardware reset the device enters Read mode when  $\overline{\text{RESET}} = V_{\text{IH}}$  and Standby mode when  $\overline{\text{RESET}} = V_{\text{IL}}$ . The DQ pins are High-Impedance when  $\overline{\text{RESET}} = V_{\text{IL}}$ . The Read operation sequence and input of any command are allowed after the device enters Read mode.

### ID READ MODE

The ID Read mode is used to establish the device type. The ID Read mode is set either from the Command mode by inputting a 90H command or from the EPROM mode by applying  $V_{\text{ID}}$  to the A9 pin.

When A0, A1 and A6 =  $V_{\text{IL}}$ , the data that is read is the manufacturer code (0098H). When A0 =  $V_{\text{IH}}$  and A1 and A6 =  $V_{\text{IL}}$ , the data that is read is the device code (TC58FVT160 : 00C2H / TC58FVB160 : 0043H). The access time for an ID Read is the same as that of a normal Read operation. DQ8 to 15 are in High-Impedance state in Byte mode.

### AUTO PROGRAM MODE

The TC58FVT160/B160 can be programmed in either byte or word units. The Auto Program mode is set using the Program command. The program address is latched on the falling edge of the  $\overline{\text{WE}}$  signal and data is latched on the rising edge of the fourth bus cycle. Auto programming starts on the rising edge of the  $\overline{\text{WE}}$  signal in the fourth bus cycle. The Program and Program Verify commands are automatically executed by the chip. The device status during programming is determined from the Hardware Sequence flag.

Programming of a protected block is ignored. The device enters Read mode 3  $\mu\text{s}$  after the rising edge of the  $\overline{\text{WE}}$  signal in the fourth bus cycle.

The device allows the programming of memory cells from 1 to 0. The programming of Memory cells from 0 to 1 will fail. A cell must be erased to turn it from 0 to 1.

If an Auto Program operation fails, the device remains in programming state and does not automatically return to Read mode. The device status can be determined from the setting of the Hardware Sequence flag. Either a Reset command or a hardware reset is necessary to return the device to Read mode after a failure.

If a programming operation fails, please do not try to use the block which contains the address to which data could not be programmed.

### Auto Chip Erase Mode

The Auto Chip Erase mode is set using the Chip Erase command. The Auto Chip Erase operation starts on the rising edge of  $\overline{\text{WE}}$  in the sixth bus cycle. All memory cells are automatically preprogrammed to 0, erased and verified as erased by the chip. The device status is determined from the Hardware Sequence flag.

Command inputs are ignored during an Auto Chip Erase. The hardware reset allows interruption of an Auto Chip Erase operation. The Auto Chip Erase operation does not complete correctly when interrupted. Hence a further Erase operation is necessary.

An attempt to erase a protected block is ignored. If all blocks are protected, the Auto Erase operation will not be executed and the device will enter Read mode 100  $\mu\text{s}$  after the rising edge of the  $\overline{\text{WE}}$  signal in the sixth bus cycle.

If an Auto Chip Erase operation fails, the device remains in, erasing state and does not return to Read mode. The device status is determined from the Hardware Sequence flag. Either a Reset command or a hardware reset is necessary to return the device to Read mode after a failure.

### Auto Block / Multi Block Erase Mode

The Auto Block and Multi Block Erase modes are set using the Block Erase command. The block address is latched on the falling edge of the  $\overline{WE}$  signal in the sixth bus cycle. The Block Erase starts as soon as the hold time has elapsed after the rising edge of the  $\overline{WE}$  signal. All memory cells in the selected block are automatically programmed to 0, erased and verified as erased by the chip. The Multi Block Erase operation allows erasing of multiple blocks. Any additional block addresses or Multi Block Erase commands must be input within the Erase Hold Time - that is, within 50  $\mu\text{s}$  of any  $\overline{WE}$  signal rising edge. The device status can be determined from the setting of the Hardware Sequence flag.

Commands (except Erase Suspend) are ignored during a Block/Multi Block Erase operation. The operation can be aborted by a hardware reset. The Auto Erase operation does not complete correctly when aborted, therefore, a further Erase operation is necessary.

An attempt to erase a protected block is ignored. If all the selected blocks are protected, the Auto Erase operation is not executed and the device returns to Read mode 100  $\mu\text{s}$  after the rising edge of the  $\overline{WE}$  signal in the last bus cycle.

If an Auto Erase operation fails, the device remains in erasing state and does not return to Read mode. The device status is determined from the Hardware Sequence flag. Either a Reset command or a hardware reset is necessary to return the device to Read mode after a failure.

### Erase Suspend / Resume Mode

The Erase Suspend mode is used to read data from a block not selected for erasing. The Erase Suspend command is allowed during a Block Erase operation or during the Block Erase Hold Time; it is ignored in other operation modes. A Block Erase operation is also suspended if the Suspend command is input during the Block Erase Hold Time. The device is reset if any command other than Suspend is input. The suspended device recognizes only Read and Resume commands.

The device enters Suspend mode 15  $\mu\text{s}$  after the Erase Suspend command is input. The device then enters a pseudo-Read Mode. Data can be read out from an unselected block but is invalid if the address is set to a block selected for erasing. The device status can be determined from the Hardware Sequence flag. DQ6 (the toggle bit) stops toggling and RDY/ $\overline{BSY}$  outputs 1 once the device is set to pseudo-Read mode. The host processor must track the current device mode since there is no way of telling whether the device is in pseudo-or ordinary Read mode. The device remains in pseudo-Read mode even if a Suspend command is input.

The device restarts the Block Erase operation after receiving a Resume command. The device returns to the status in which the Suspend command was input. The DQ6 output toggles and RDY/ $\overline{BSY}$  outputs a 0.

### BLOCK PROTECT

The TC58FVT160/B160 has a block protection feature to prevent programming and erasing of protected blocks. Block protection is enabled by either hardware protection (1) or a software command mode (2). The initial device is shipped with all blocks unprotected.

- (1) A blocks is protected when:  $A9 = \overline{OE} = V_{ID}$ ,  $\overline{CE} = V_{IL}$ ,  $A0 / A6 = V_{IL}$ ,  $A1 = V_{IH}$ ; the block address is set using A12 to A19. The block protect data is programmed within  $t_{PPLH}$  of the  $\overline{WE}$  signal going Low.
- (2) A block can also be protected using a software command. Block protection is executed by setting the  $\overline{WE}$  signal to Low for  $t_{PPLH}$  while  $\overline{CE} = V_{IL}$ . After the command input in the sixth bus cycle A12 to A19 = the block address. Block protection can be verified using the Verify Block Protect command.

### TEMPORARY BLOCK UNPROTECTION

The TC58FVT160/B160 has a temporary block unprotection feature which disables block protection for all protected blocks. Unprotection is enabled by applying  $V_{ID}$  to the  $\overline{RESET}$  pin. In this state any block can be programmed or erased. The device returns to the previous condition after  $V_{ID}$  is removed from the  $\overline{RESET}$  pin. That is, previously protected blocks are protected again.

### VERIFY BLOCK PROTECT

The Verify Block Protect command is used to check whether a block is protected or unprotected. Verify Block Protect is enabled either through hardware (1) or by a software command (2). In Word mode 0001H is output when the block is protected and 0000H is output when it is unprotected. DQ8 to 15 are High-Impedance in Byte mode.

- (1) Verify Block Protection is enabled when:  $A9 = V_{ID}$ ,  $A0$  and  $A6 = V_{IL}$  and  $A1 = V_{IH}$ .  
A12 to A19 = the block address.
- (2) Verify Block Protection can also be enabled using a software command.

### HARDWARE SEQUENCE FLAG

The TC58FVT160/B160 has a Hardware Sequence flag which allows the device status to be determined during Auto operation. The output data is read out with the same timing as Read mode at  $\overline{CE} = \overline{OE} = V_{IL}$ .  $\overline{RDY/BSY}$  outputs either High or Low.

The device re-enters the Read mode automatically after Auto operation has completed successfully. The device status is read out from the Hardware Sequence flag and the operation result is verified by comparing the read-out data to the original data.

#### DQ7 ( $\overline{DATA}$ Polling)

The device status can be determined using the data polling function during an Auto Program or Auto Erase operation.  $\overline{DATA}$  polling begins on the rising edge of  $\overline{WE}$  in the last bus cycle. In an Auto Program operation, DQ7 outputs inverted data during the programming operation and outputs real data after programming has finished. In an Auto Erase operation, DQ7 outputs 0 during the Erase operation and outputs 1 when the Erase operation has finished. If an Auto Program or Auto Erase operation fails, DQ7 simply outputs the data.

The latched address is reset after an operation has finished. The polling data is asynchronous with the  $\overline{OE}$  signal.

#### DQ6 (Toggle Bit)

The device status can be determined by the Toggle Bit function during an Auto Program or Auto Erase operation. The Toggle bit begins toggling on the rising edge of  $\overline{WE}$  in the last bus cycle. DQ6 alternately outputs a 0 or a 1 for each attempt ( $\overline{OE}$  access) while  $\overline{CE} = V_{IL}$  while the device is busy. When the internal operation has been completed, toggling stops and valid memory cell data can be read by subsequent reading. If the operation failed, the DQ6 output toggles.

DQ6 toggles for around 3  $\mu s$  when an attempt is made to execute an Auto Program operation on a protected block. It then stops toggling. DQ6 toggles for around 100  $\mu s$  when an attempt is made to execute an Auto Erase operation on a protected block. It then stops toggling. After toggling stops the device returns to Read mode.

#### DQ5 (Internal Time-out)

DQ5 outputs a 1 when the Internal Timer has timed out during a Program or Erase operation. This indicates that the operation has not completed within the allotted time.

An attempt to program 1 into a cell containing 0 will fail (see Auto Program mode). DQ5 outputs 1 in this case. Either a hardware reset or a software Reset command is required to put the device into Read mode.

### DQ3 (Block Erase Timer)

The Block Erase operation starts 50  $\mu$ s (Erase Hold Time) after the rising edge of  $\overline{WE}$  in the last command cycle. DQ3 outputs a 0 during the Block Erase Hold Time and a 1 when the Erase operation starts. Additional Block Erase commands can only be accepted during this Block Erase Hold Time. Each Block Erase command received within this hold time resets the timer, allowing additional blocks to be marked for erasing. DQ3 outputs a 1 if the Program or Erase operation fails.

### RDY/ $\overline{BSY}$ (READY/BUSY)

TC58FVT160/B160 has a RDY/ $\overline{BSY}$  signal to indicate the device status to the host processor. A 0 (Busy state) indicates that an Auto Program or Auto Erase operation is in progress. A 1 (Ready state) indicates that the operation has finished and that the device can accept a new command. The RDY/ $\overline{BSY}$  signal outputs a 0 when an operation has failed.

The RDY/ $\overline{BSY}$  signal outputs a 0 after the rising edge of  $\overline{WE}$  in the last command cycle.

During an Auto Block Erase operation, commands other than Erase Suspend are ignored. The RDY/ $\overline{BSY}$  signal outputs a 1 during an Erase Suspend operation. The output buffer for the RDY/ $\overline{BSY}$  pin is an open drain type circuit, allowing a wired-OR connection. A pull-up resistor needs to be inserted between  $V_{DD}$  and the RDY/ $\overline{BSY}$  pin.

### DATA PROTECTION

The TC58FVT160/B160 utilizes a JEDEC standard command sequence which protects data against accidental alteration due to noise.

### $V_{DD}$ Lock-out Voltage

The device is reset when  $V_{DD}$  is less than  $V_{LKO}$  to protect memory cell data against  $V_{DD}$  noise, and during power-up and power-down. An Auto Program or Erase operation stops when  $V_{DD}$  drops below  $V_{LKO}$ . An Erase Suspend operation is reset and an Erase operation stops if the device is in Suspend mode. An operation will not complete correctly if it is interrupted by  $V_{DD}$  Lock-out.

### $\overline{WE}$ Glitch Pulses

Glitches must be suppressed (to less than 5 ns) in order for operation to proceed smoothly.

### Protection at Power-on

A command is not recognized on the rising edge of  $\overline{WE}$  if  $V_{DD}$  rises from 0 V to the operating voltage while  $\overline{WE} = V_{IL}$ ,  $\overline{CE} = V_{IL}$  and  $\overline{OE} = V_{IH}$ . In this case the device is reset and enters Read mode.

**TIMING DIAGRAMS**

Read / ID Read Operation

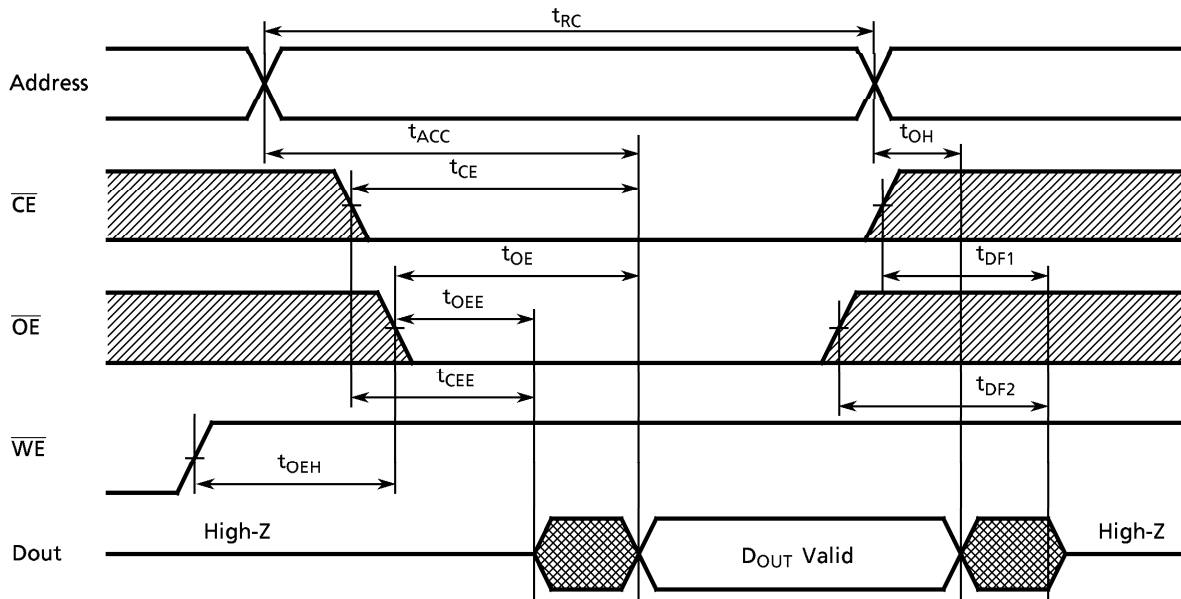

ID Read Operation (Hardware)

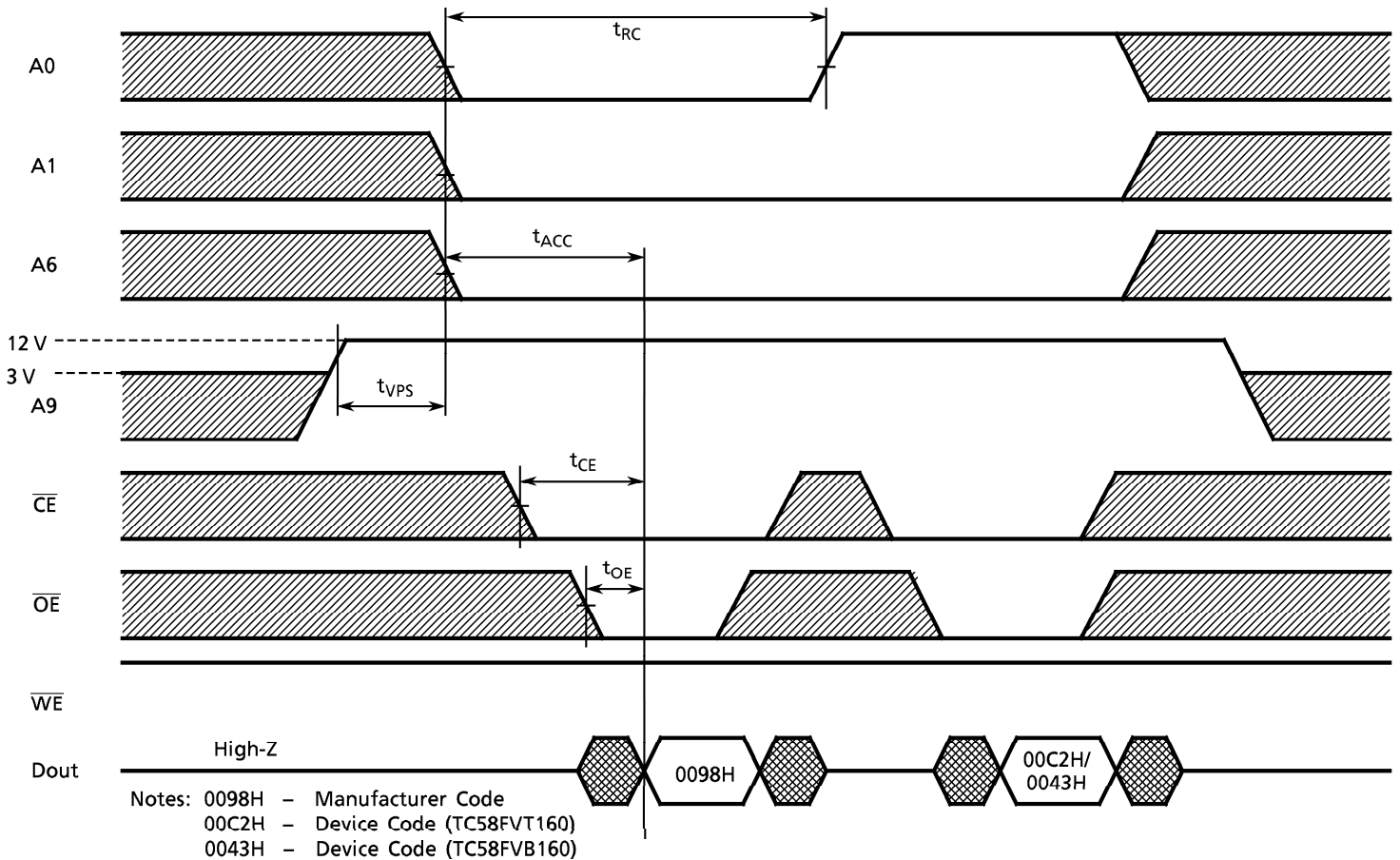



Auto Program Operation ( $\overline{CE}$  Control)

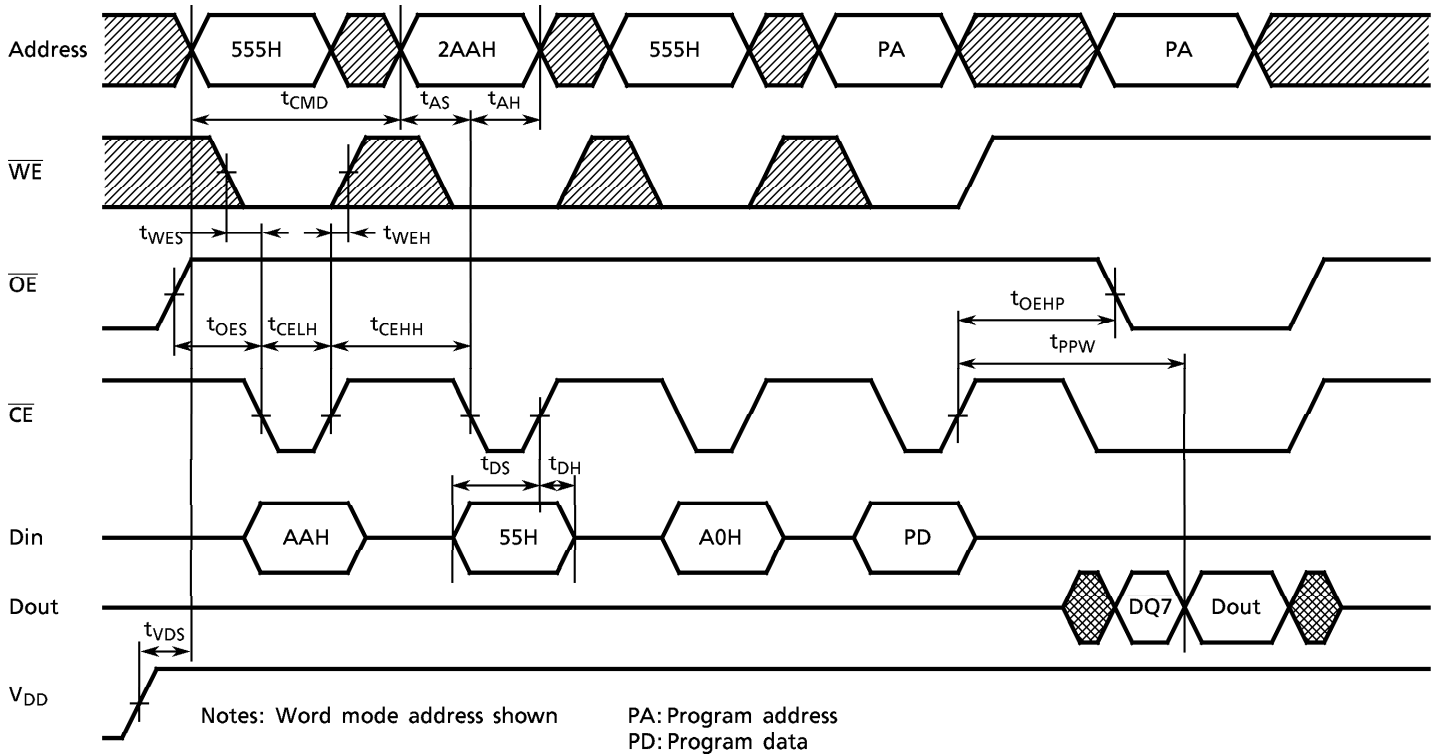

Auto Chip Erase / Auto Block Erase Operation ( $\overline{CE}$  Control)

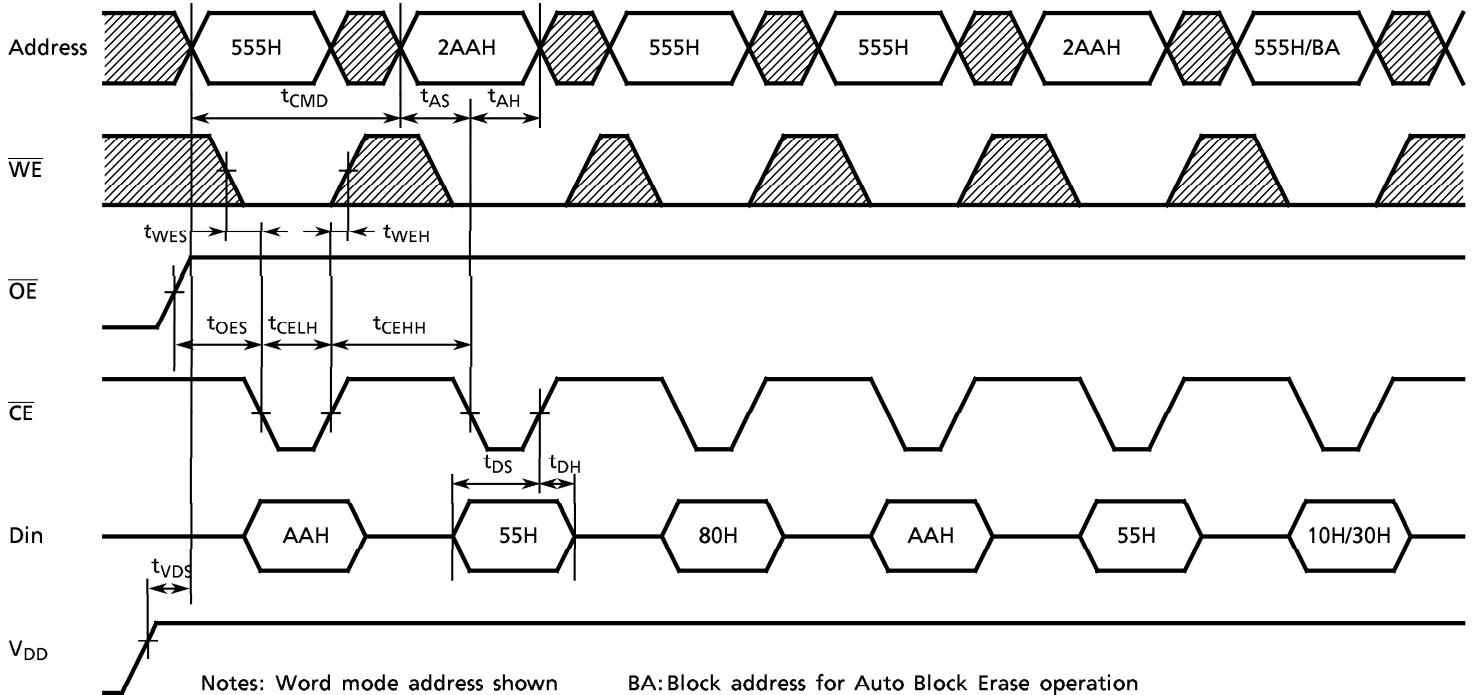

Auto Program Operation ( $\overline{WE}$  Control)

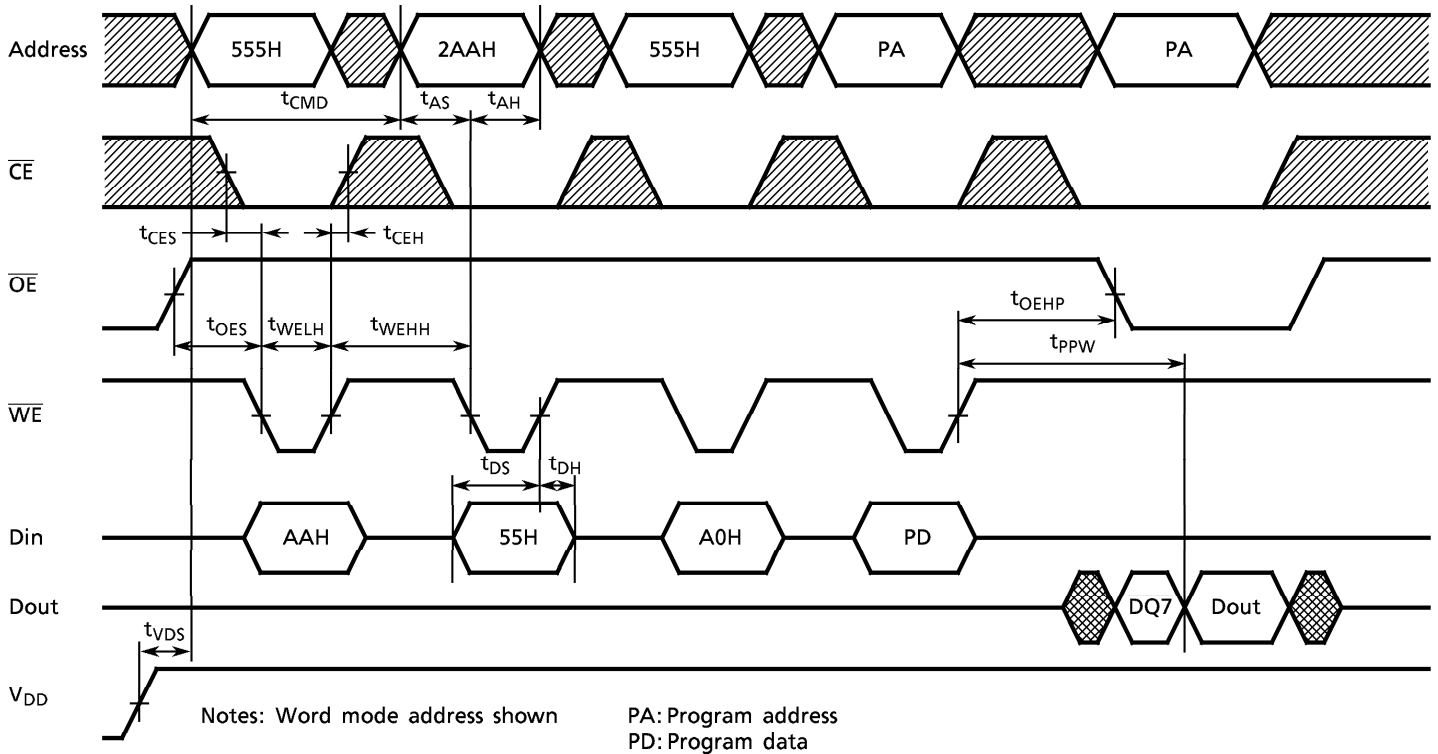

Auto Chip Erase / Auto Block Erase Operation ( $\overline{WE}$  Control)

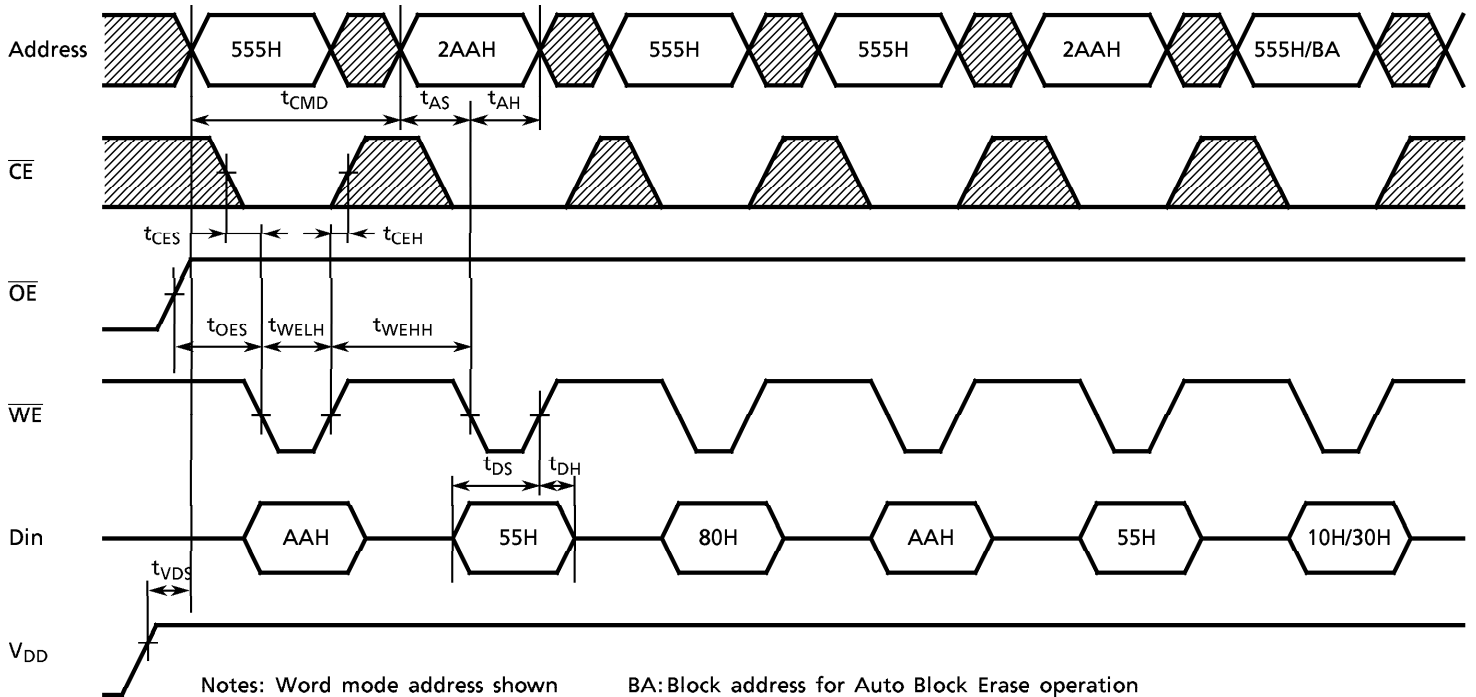

DATA Polling during Program/Erase Operation

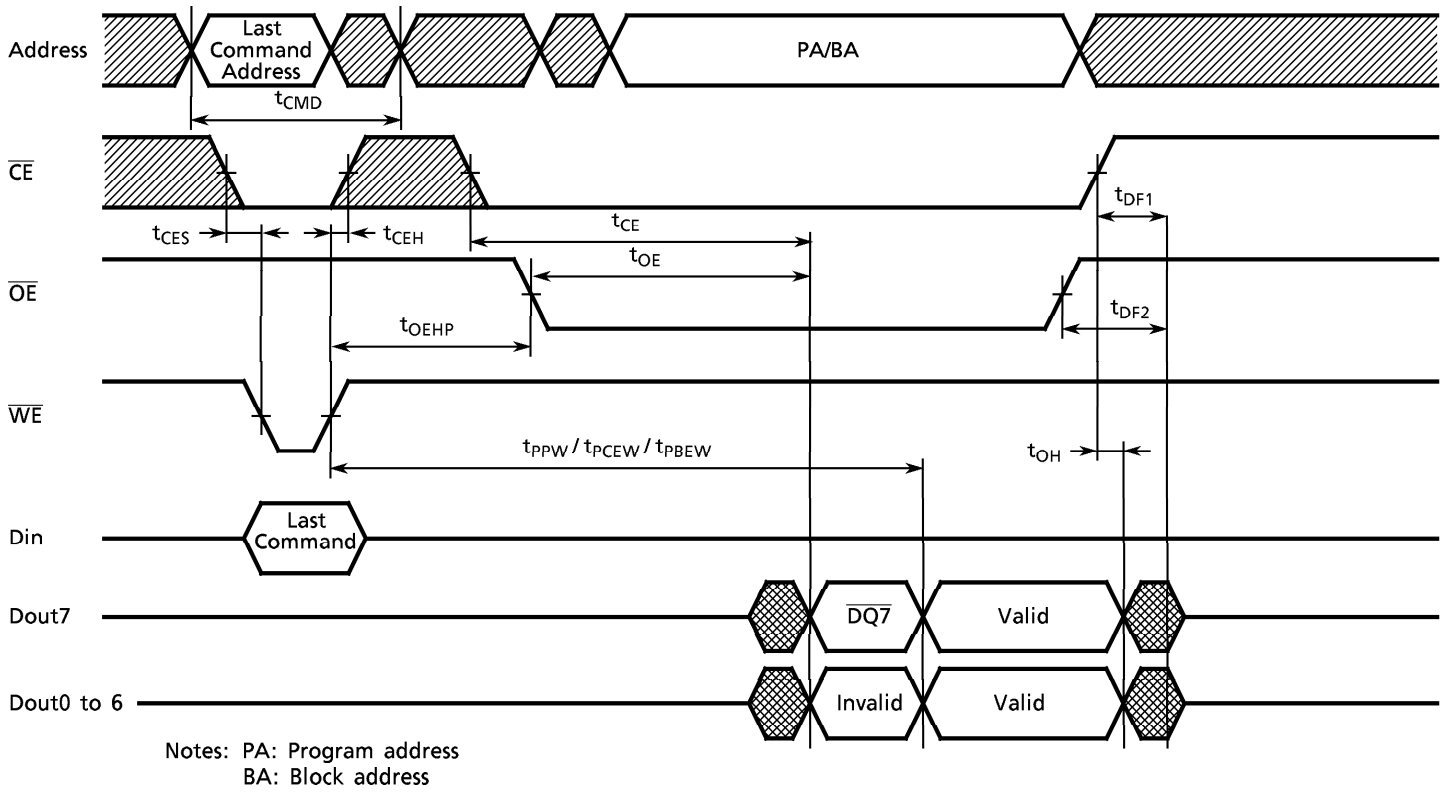

Toggle Bit during Program/Erase Operation

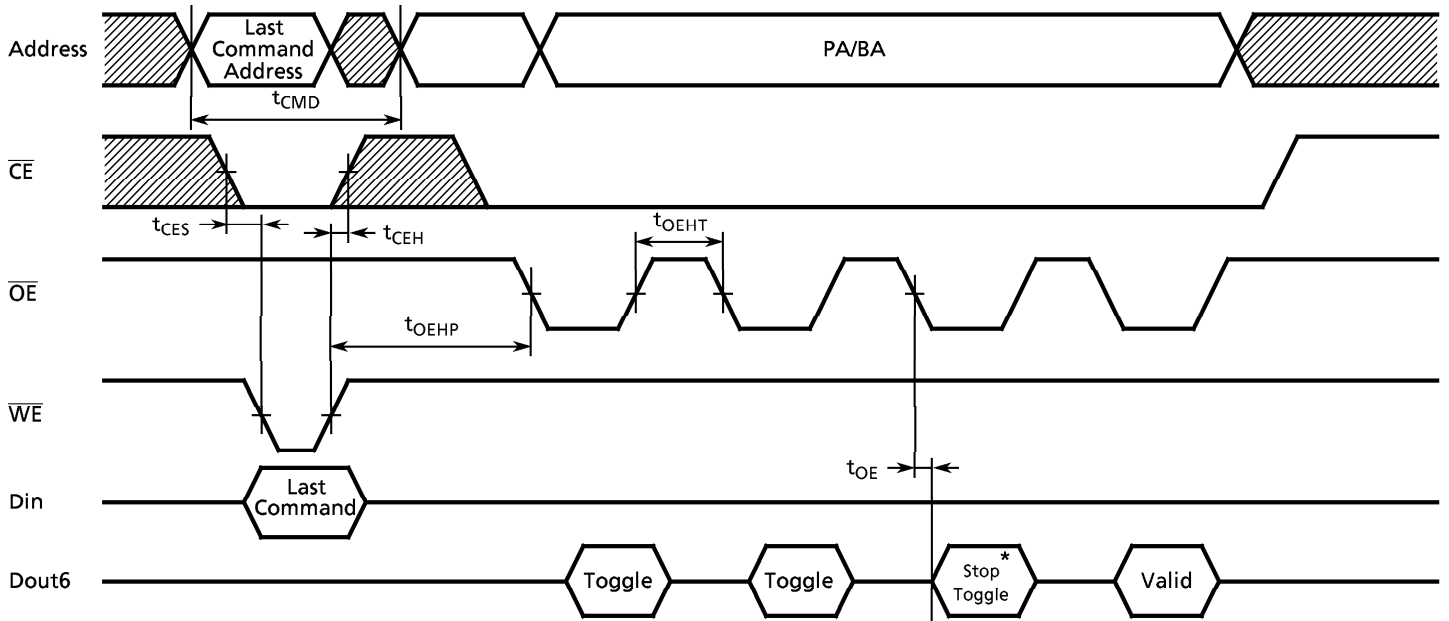

Erase Suspend Operation

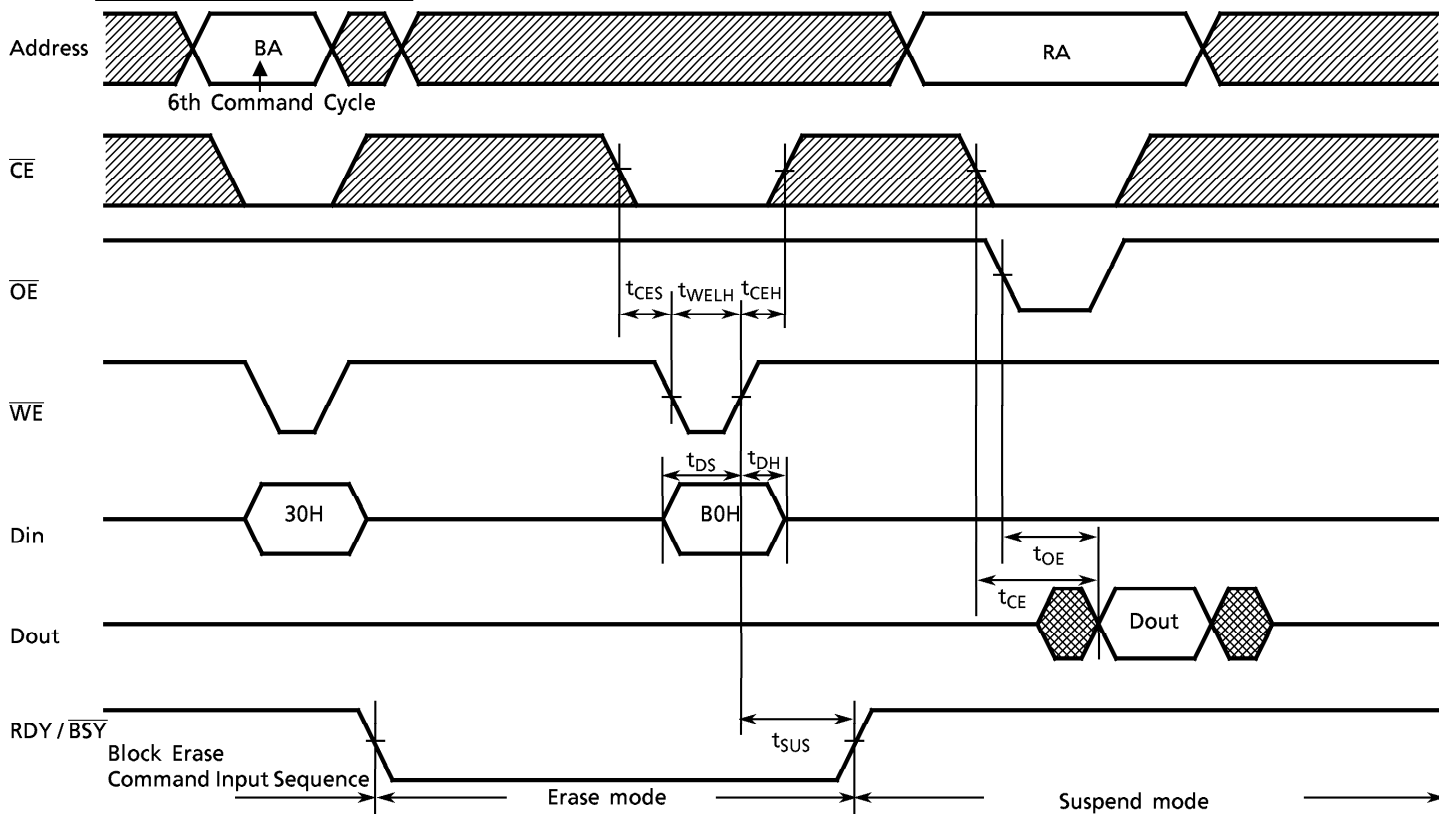

Notes : BA : Block address  
RA : Read address

Resume Operation

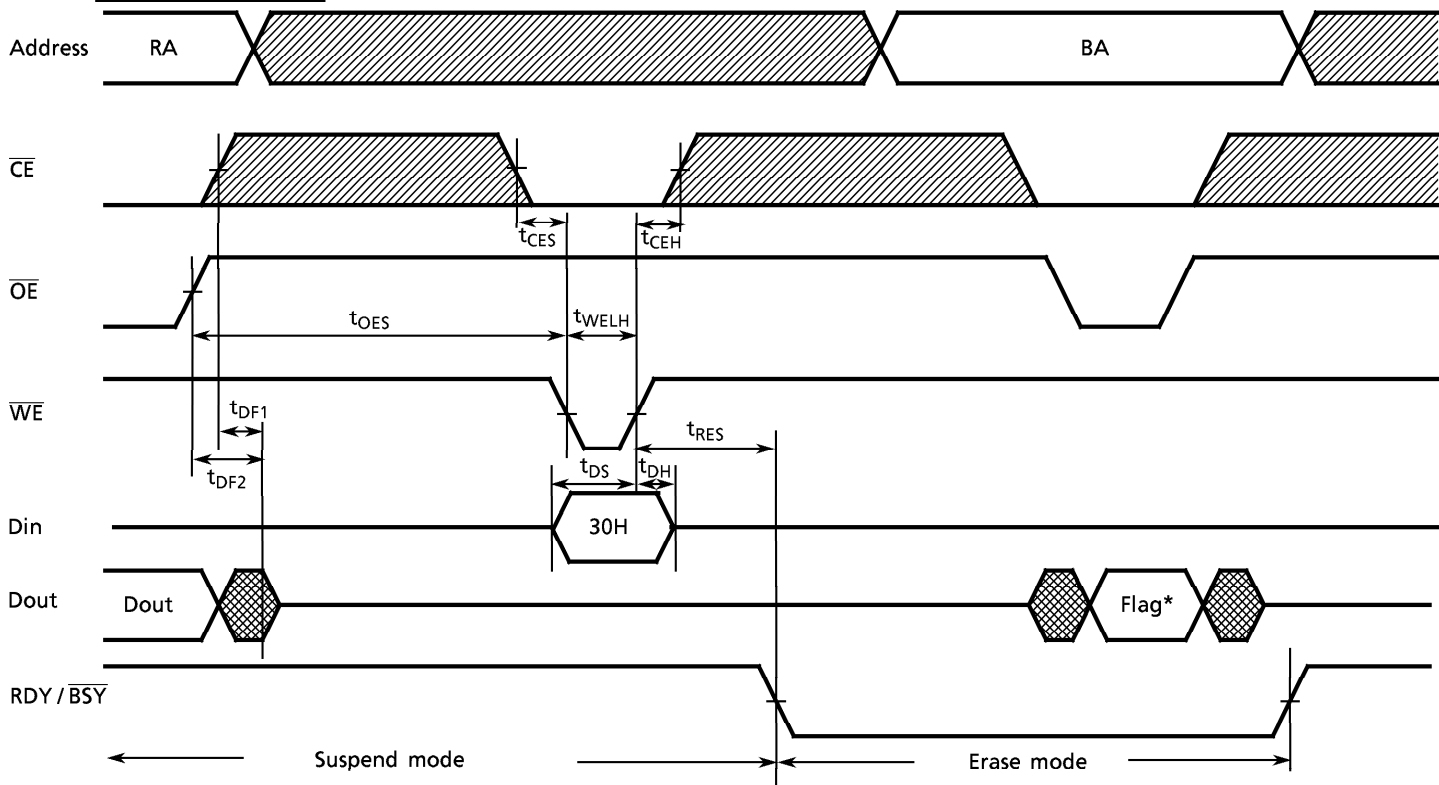

Notes : RA : Read address  
BA : Block address  
\* Flag : Hardware sequence flag

RDY/BSY during Auto Program/Erase Operation

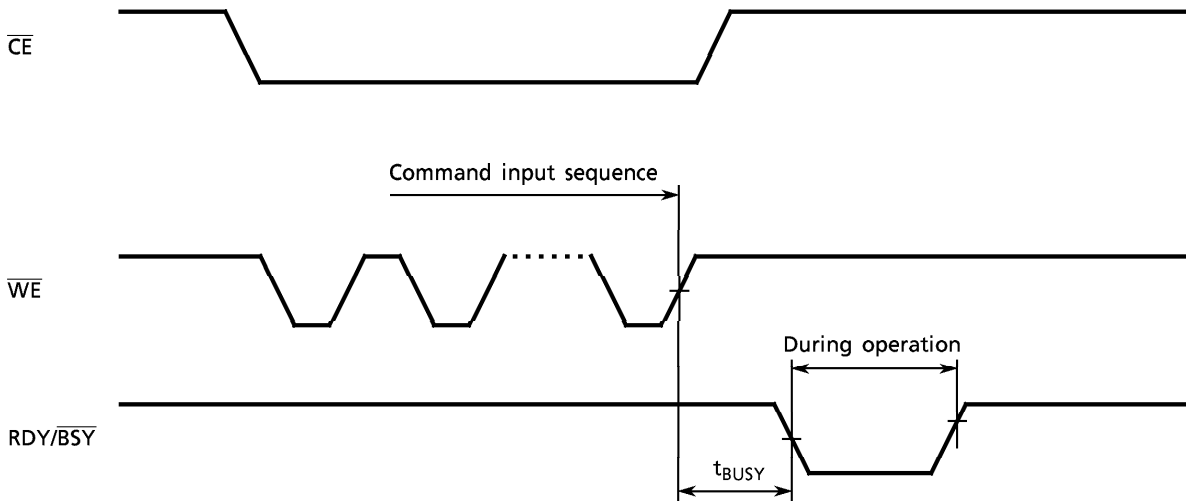

Hardware Reset Operation

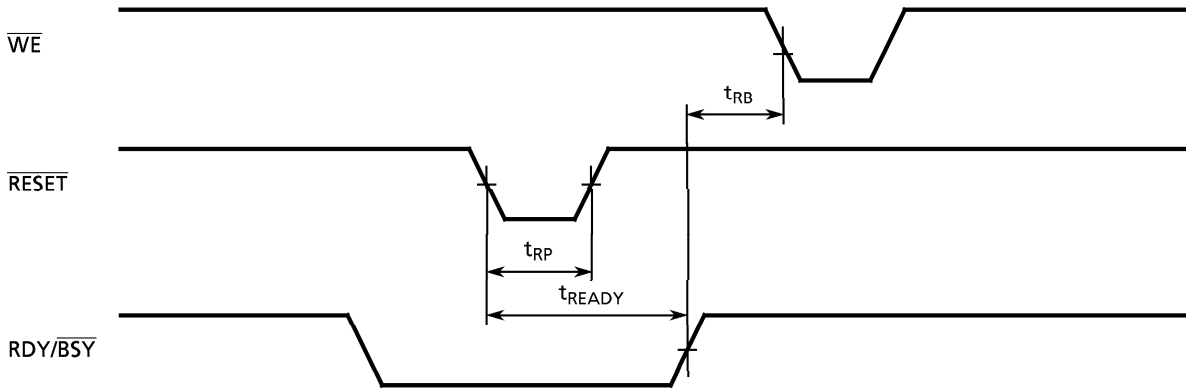

Read after RESET

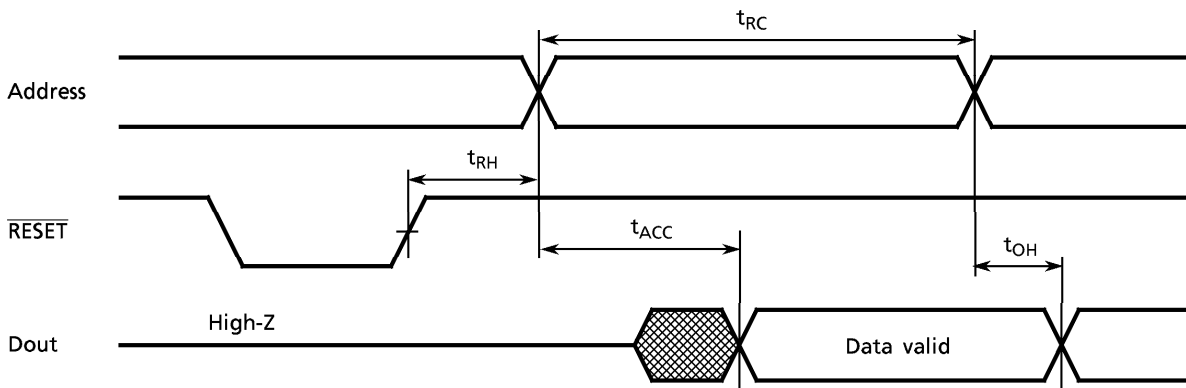

BYTE during Read Operation

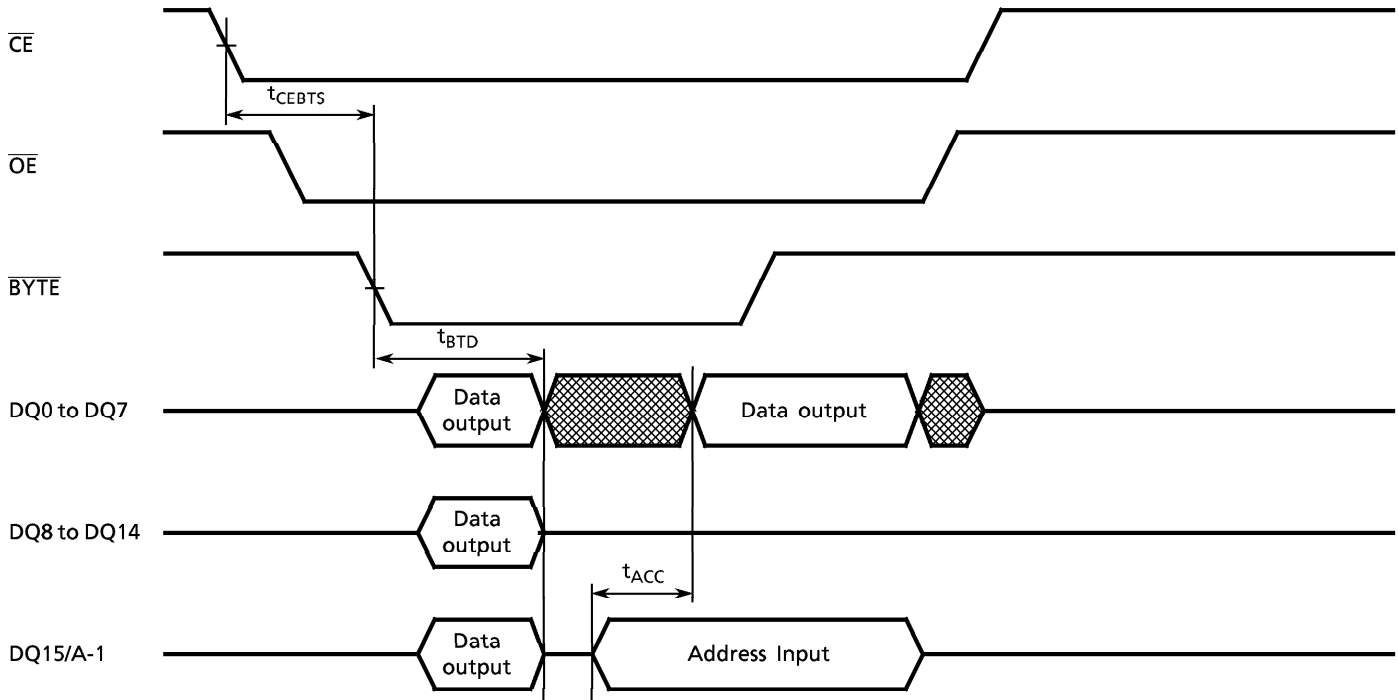

BYTE during Write Operation

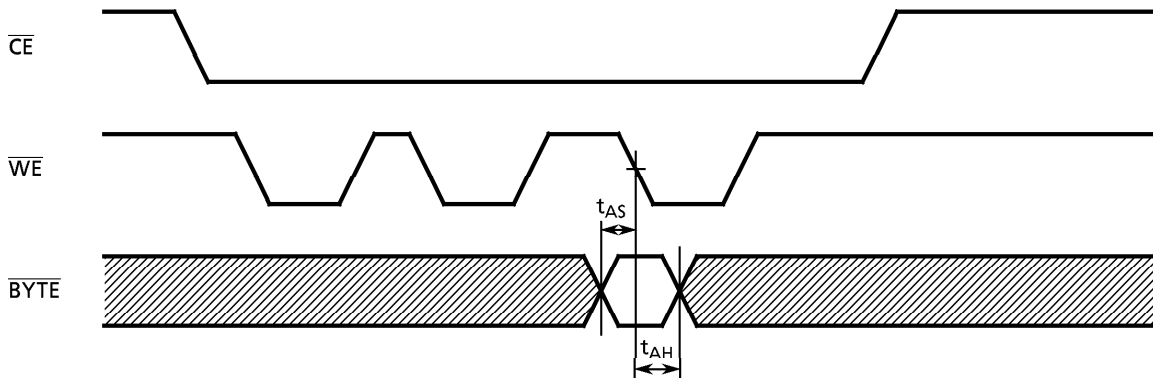

Block Protect Operation (Hardware)

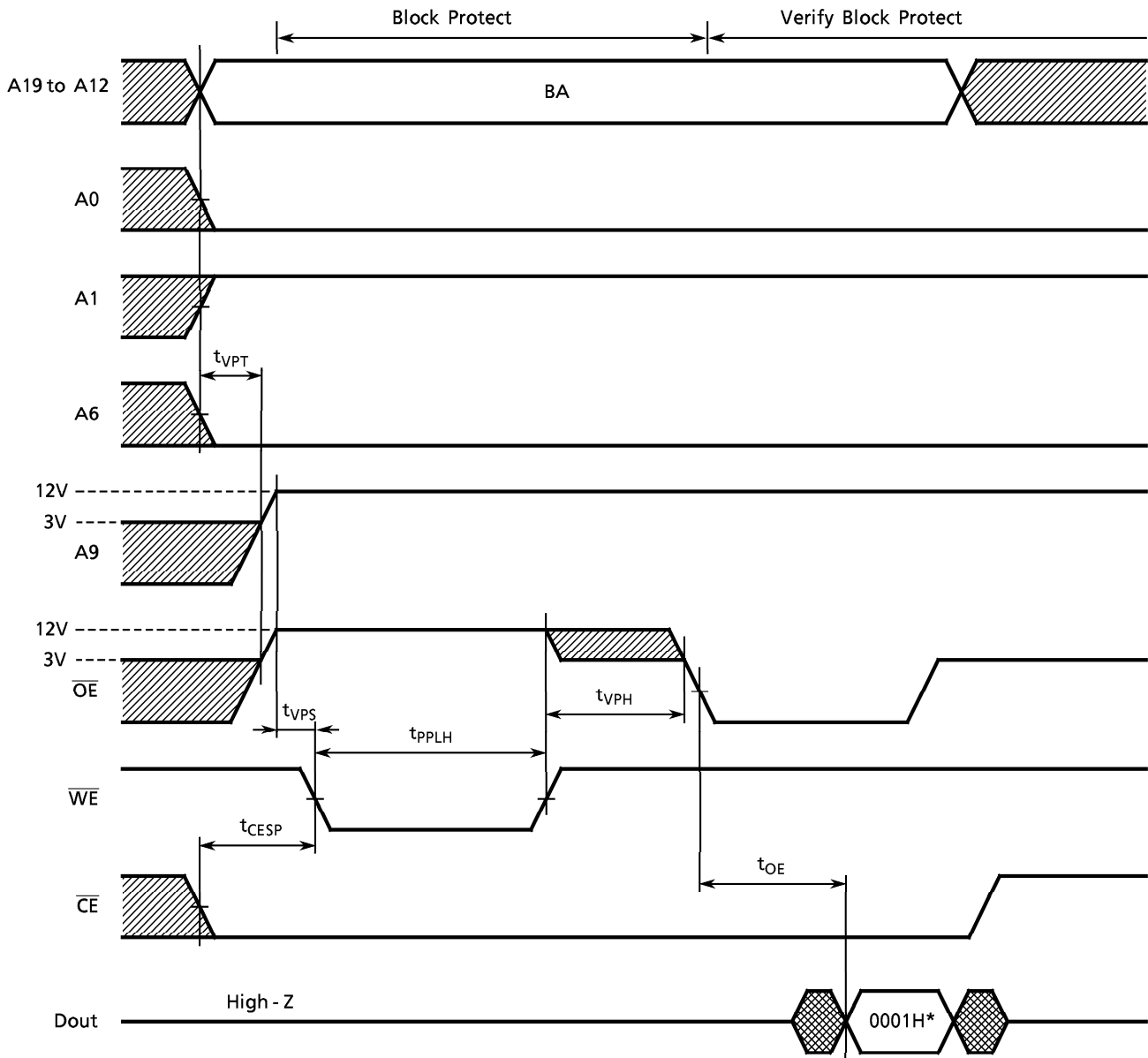

BA : Block address

\* : 0001H indicates that block is protected.

Block Protect (Software)

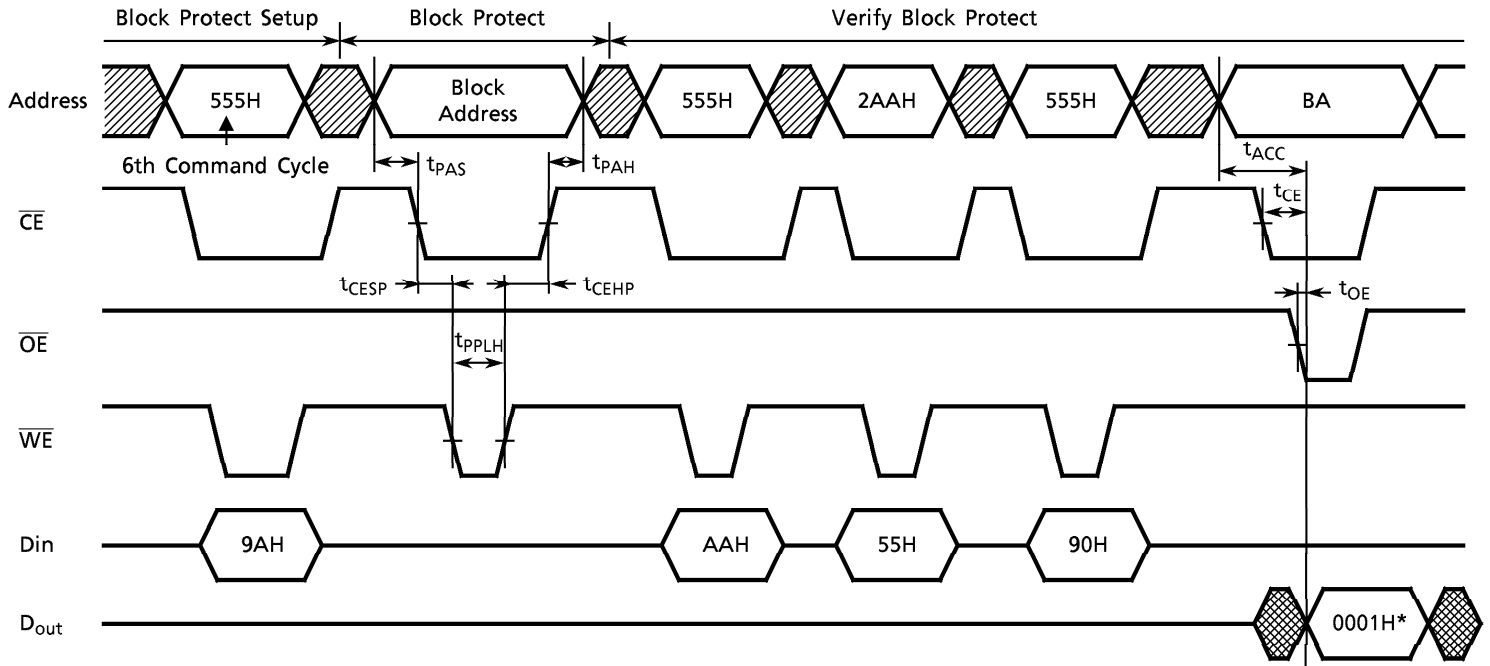

BA : Block address

\* : 0001H indicates that block is protected.



FLOWCHARTS

Auto Program

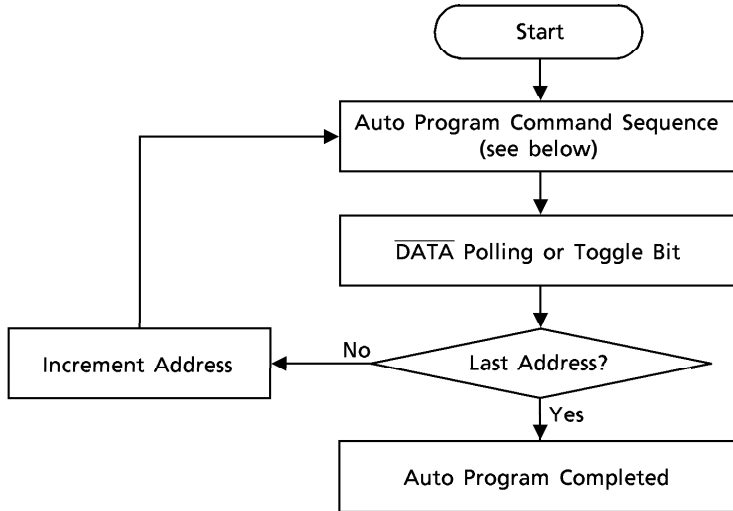

Auto Program Command Sequence (Address/Command)

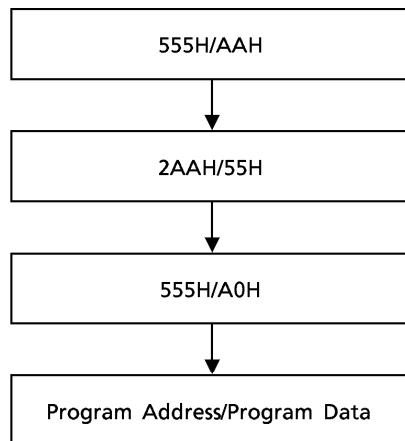

Note: Word mode command sequence is shown.

Auto Erase

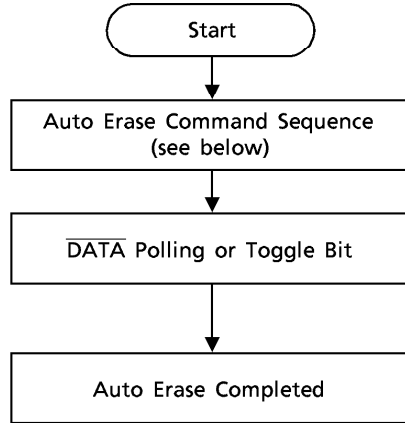

Auto Chip Erase Command Sequence  
(Address/Command)

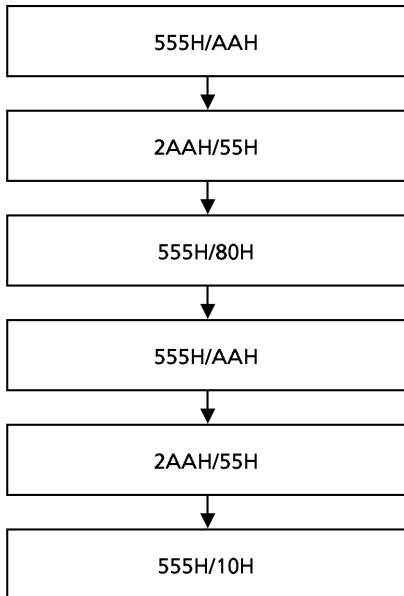

Auto Block/Multiple Block  
Erase Command Sequence (Address/Command)

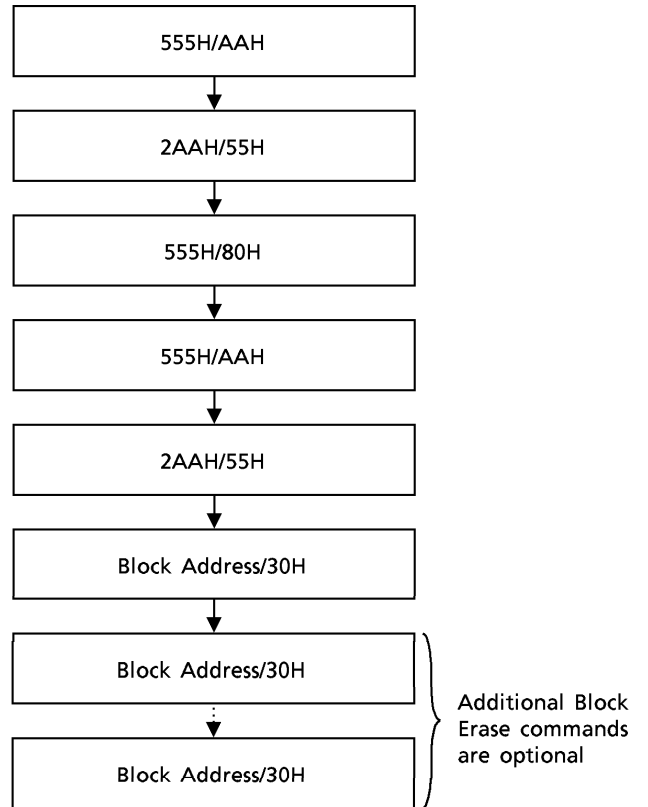

Note: Word mode command sequence is shown.

DQ7 DATA Polling

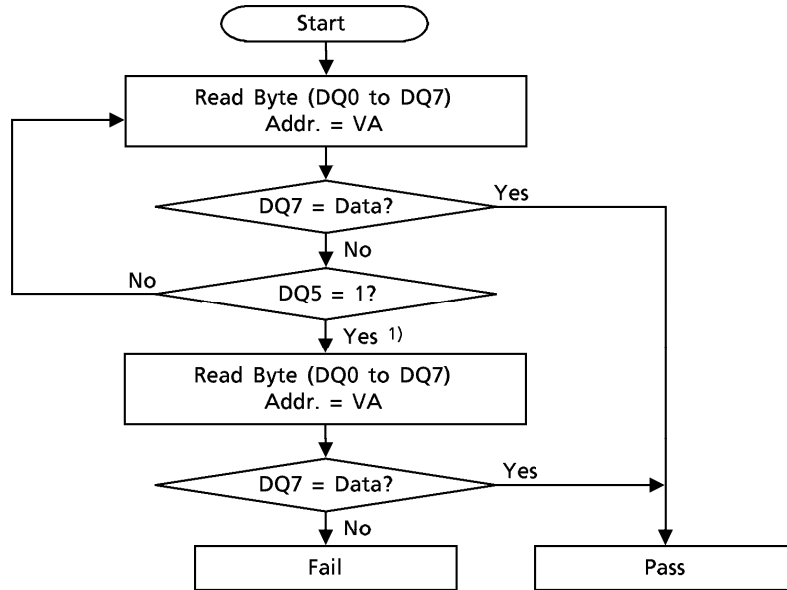

VA: Byte address for programming.  
Any of the addresses within the block being erased during a Block Erase operation.  
Don't care during a Chip Erase operation

Note: 1) DQ7 must be rechecked even if DQ5 = 1 because DQ7 may change at the same time as DQ5.

DQ6 Toggle Bit

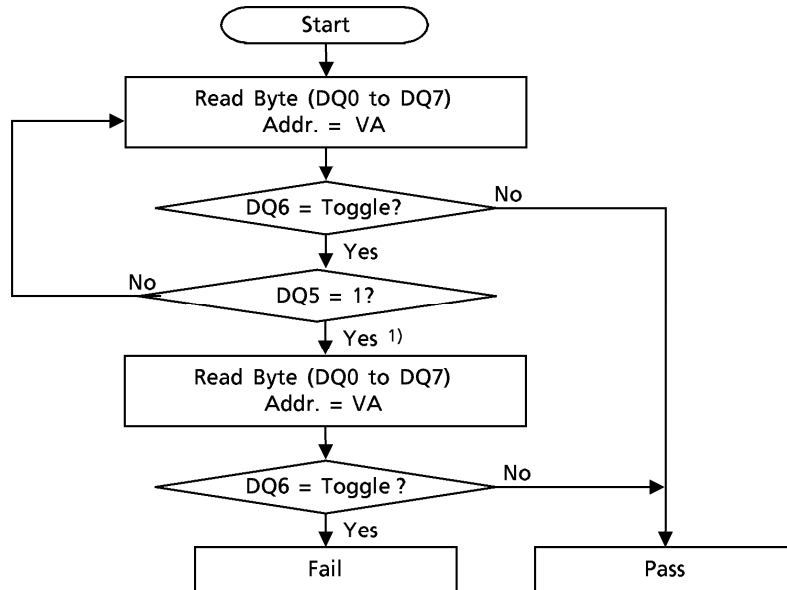

VA: Byte address for programming.  
Any of the addresses within the block being erased during a Block Erase operation.  
Don't care during a Chip Erase operation  
Any address not within the current block during an Erase Suspend operation

Note: 1) DQ6 must be rechecked even if DQ5 = 1 because DQ6 may stop toggling at the same time that DQ5 changes to 1.

Block Protect (Hardware)

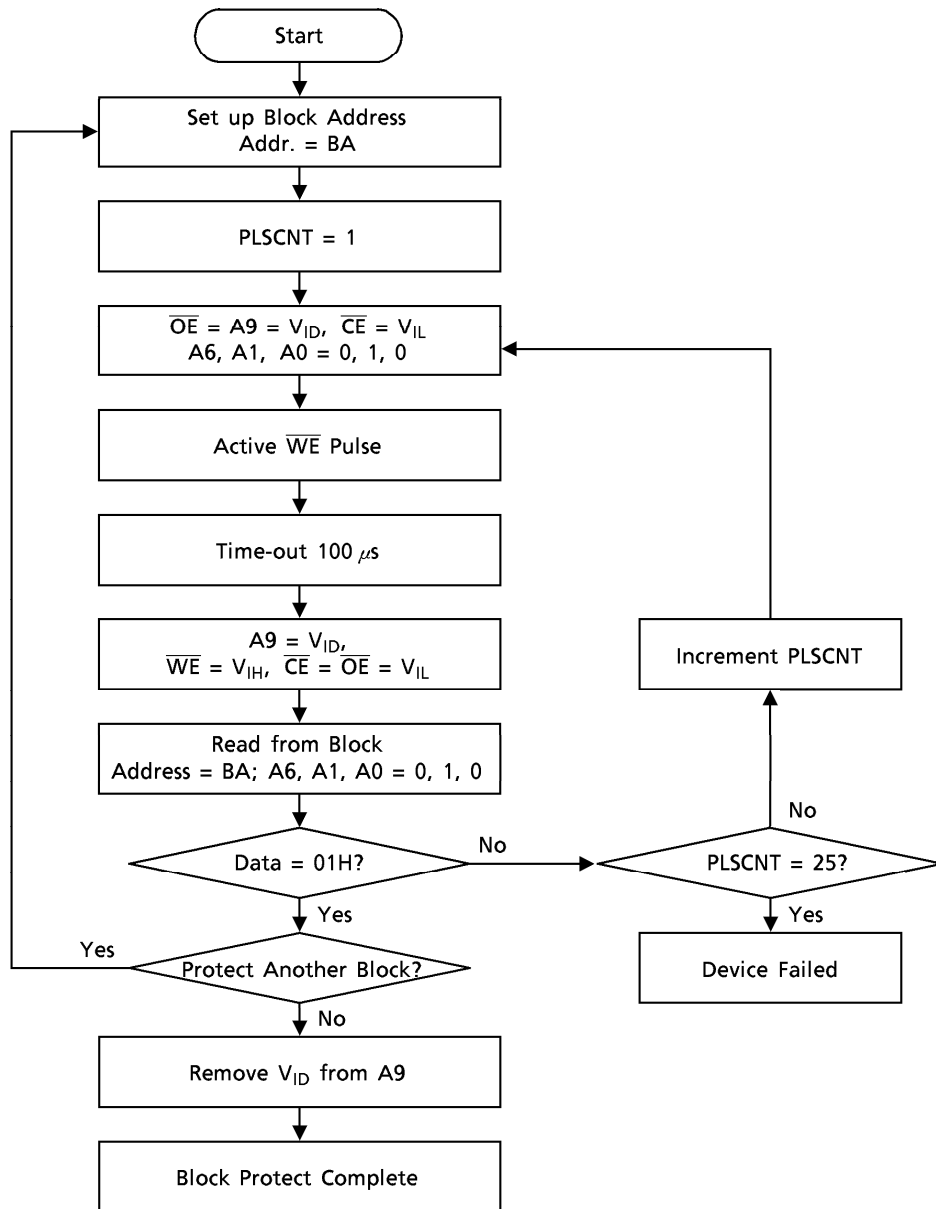

BA: Block address

Block Protect (Software)

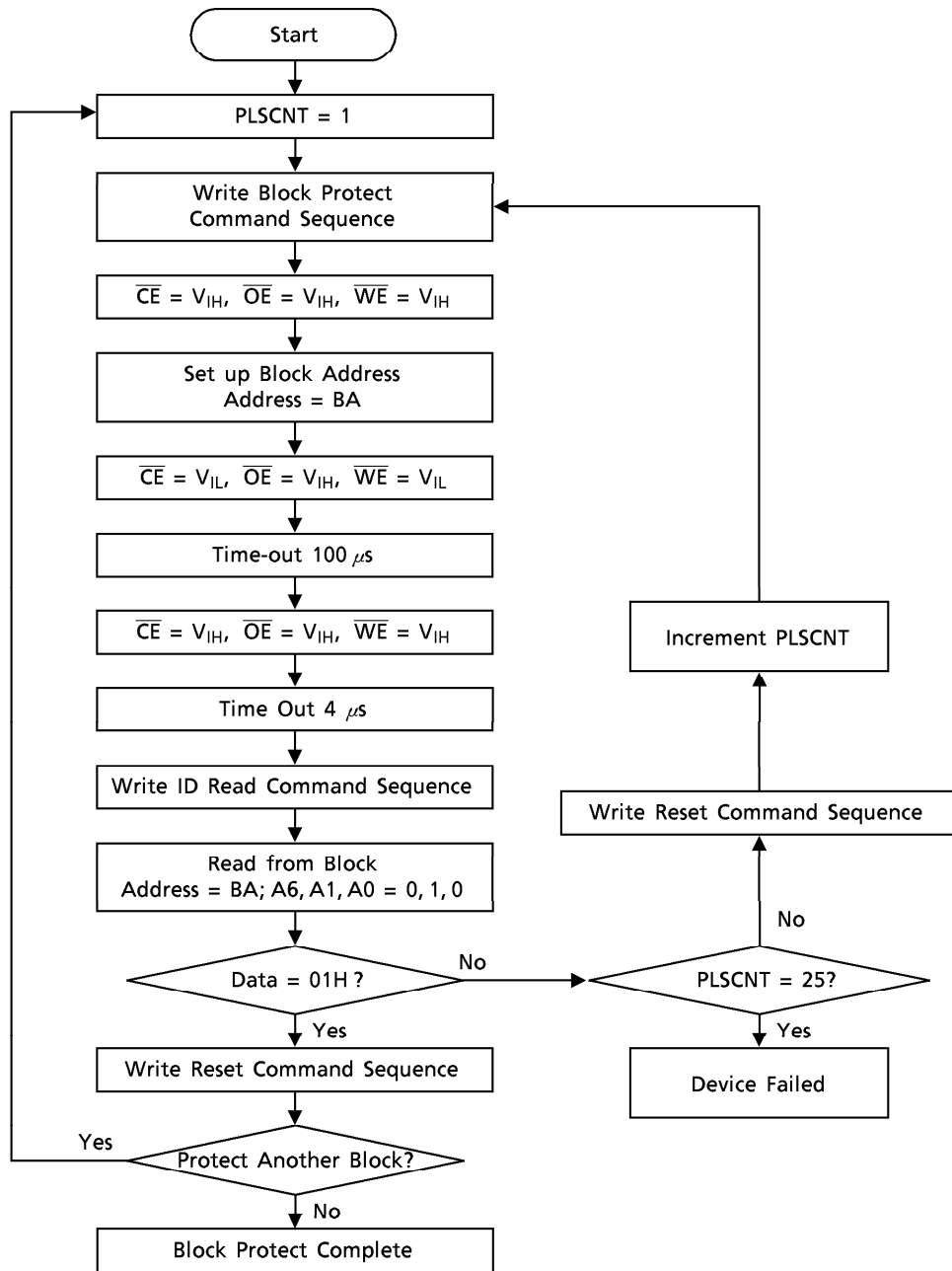

BA: Block Address

**PACKAGE DIMENSIONS**

- Plastic TSOP

TSOP I 48-P-1220-0.50

Unit: mm

