

1.24V ADJUSTABLE PRECISION SHUNT REGULATORS

Description

The GM432's are low-voltage three-terminal adjustable precision shunt regulators with specified thermal stability over their full temperature range. Output voltage can be set to any value from V_{ref} (1.24V) to 16V by using two external resistors. Their active output circuitry provides a very unique turn-on characteristic, making them excellent replacements for zener diodes in many applications such as onboard regulation and adjustable power supplies. In a wide range of home applications, these versatile darlings are ideal voltage references for 3.0V to 3.3V switching power supplies. With operational cathode current as low as 80 μ A, batteries keep on going. Whatever your application is, the GM432's offer the optimum combination of performance, reliability, and economy.

Features

- ◆ Low-voltage operation, down to 1.24V
- ◆ 0.5%, 1% or 2% reference voltage tolerance
- ◆ Adjustable output voltage, $V_O = V_{ref}$ to 16V
- ◆ Sink Current Capability 80 μ A to 100mA
- ◆ Low dynamic output impedance, 0.05 Ω typical
- ◆ Wide temperature range, 0° to +70°C
- ◆ Pin-to-pin replacement for TLV431, SC431L
- ◆ Available in SOT-23, SOT-25, SOT-89, TO-92 and SOP-8

Application

Switching power supplies
 Linear regulators
 Adjustable supplies
 Instrumentation

Battery-operated computers,
 PDA's portable devices
 Monitors, TV's, camcorders
 Computer disk drives

LOGIC SYMBOL



BLOCK DIAGRAM (POSITIVE LOGIC)

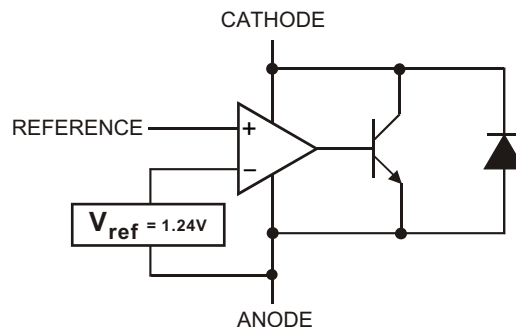

1.24V ADJUSTABLE PRECISION SHUNT REGULATORS

◆ MARKING INFORMATION & PIN CONFIGURATIONS (TOP VIEW)

SOT-25(SOT-23-5)

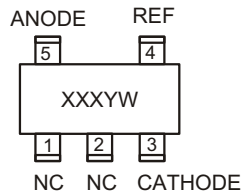

SOT-23

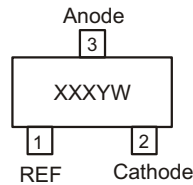

TO-92

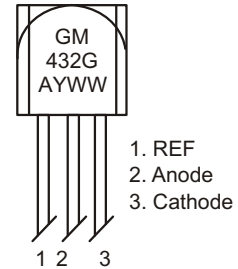

SOT-89

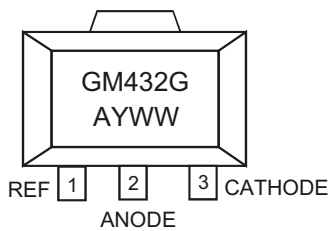

SOP-8

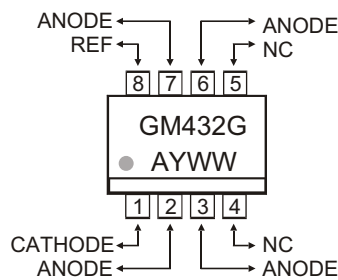

XXX = Marking Code
 G** = Grade
 A = Assembly Location
 Y = Year
 WW, W= Weekly

◆ ORDERING INFORMATION

Ordering Number	Precision	Device code	Grade	Package	Shipping
GM432AT92B	0.5%	MAA	A	TO-92	1,000 Units/ ESD Bag
GM432AT92RL	0.5%	MAA	A	TO-92	2,000 Units/ Ammo Pack(Tape)
GM432AST23R	0.5%	MAA		SOT-23	3,000 Units/Tape & Reel
GM432AST25R	0.5%	MAA		SOT-25	3,000 Units/Tape & Reel
GM432AS8R	0.5%	MAA		SOP-8	2,500 Units/Tape & Reel
GM432AST89R	0.5%	MAA		SOT-89	1,000 Units/ Tape & Reel
GM432BT92B	1%	MAB	B	TO-92	1,000 Units/ ESD Bag
GM432BT92RL	1%	MAB	B	TO-92	2,000 Units/ Ammo Pack(Tape)
GM432BST23R	1%	MAB		SOT-23	3,000 Units/Tape & Reel
GM432BST25R	1%	MAB		SOT-25	3,000 Units/Tape & Reel
GM432BS8R	1%	MAB		SOP-8	2,500 Units/Tape & Reel
GM432BST89R	1%	MAB		SOT-89	1,000 Units/ Tape & Reel
GM432CT92B	2%	MAC	C	TO-92	1,000 Units/ ESD Bag
GM432CT92RL	2%	MAC	C	TO-92	2,000 Units/ Ammo Pack(Tape)
GM432CST23R	2%	MAC		SOT-23	3,000 Units/Tape & Reel
GM432CST25R	2%	MAC		SOT-25	3,000 Units/Tape & Reel
GM432CS8R	2%	MAC		SOP-8	2,500 Units/Tape & Reel
GM432CST89R	2%	MAC		SOT-89	1,000 Units/ Tape & Reel

* For detail Ordering Number identification, please see last page.

**Grade A: indicates Precision of 0.5%, B: indicates Precision of 1%, C: indicates Precision of 2%

1.24V ADJUSTABLE PRECISION SHUNT REGULATORS

◆ ABSOLUTE MAXIMUM RATINGS (over free-air temperature range except as noted)

PARAMETER	SYMBOL	VALUE	UNIT
Cathode Voltage ⁽¹⁾	V_{KA}	20	V
Continuous cathode current	I_K	100	mA
Reference input current range	I_{ref}	3	mA
Power dissipation at $T_A = 25^\circ\text{C}$ SOT-23 SOP-8 TO-92	P_D	0.37 0.49 0.95	W
Package thermal impedance ^(2,3) SOT-23 SOT-25 TO-92 SOP-8	J_A	336 256 132 97	$^\circ\text{C/W}$
Operating ambient temperature range	T_A	0 to + 70	$^\circ\text{C}$
Lead temperature (soldering) 10 seconds	T_{LEAD}	260	$^\circ\text{C}$

These are stress ratings only. Functional operation of the device at these or any conditions beyond the "recommended operating conditions" is not implied. Exposure to absolute maximum rated conditions may affect device reliability.

NOTES:

- Voltage values are with respect to the anode except as noted.
- Maximum power dissipation is a function of $T_{J(max)}$, J_A and T_A . Maximum allowable power dissipation at any allowable ambient temperature is $P_D = (T_{J(max)} - T_A) / J_A$.
- Package thermal impedance is calculated per JESD 51.

◆ RECOMMENDED OPERATING CONDITIONS

PARAMETER	SYMBOL	MINIMUM	MAXIMUM	UNIT
Cathode Voltage	V_{KA}	V_{ref}	16	V
Cathode Current	I_K	80 μA	100	mA

1.24V ADJUSTABLE PRECISION SHUNT REGULATORS

◆ ELECTRICAL CHARACTERISTICS ($T_A = 25^\circ\text{C}$ unless otherwise noted)

GM432A (0.5%)

PARAMETER		CONDITION	MIN	TYP	MAX	UNIT
Reference input Voltage	V_{ref}	$V_{\text{KA}} = V_{\text{ref}}, I_{\text{K}} = 10 \text{ mA}, T_A = 25^\circ\text{C}^{(1)}$ $V_{\text{KA}} = V_{\text{ref}}, I_{\text{K}} = 10 \text{ mA}, T_A = 0 \text{ to } +70^\circ\text{C}^{(1)}$	1.234 1.222	1.240	1.246 1.258	V
V_{ref} temp deviation	V_{dev}	$V_{\text{KA}} = V_{\text{ref}}, I_{\text{K}} = 10 \text{ mA}^{(1)}$		10	25	mV
Ratio of change in V_{ref} to change in V_{KA}	$\frac{V_{\text{ref}}}{V_{\text{KA}}}$	$I_{\text{K}} = 10 \text{ mA}, V_{\text{KA}} = 16 \text{ V to } V_{\text{ref}}$	-2.7	-1.0		mV/V
Reference input current	I_{ref}	$I_{\text{K}} = 10 \text{ mA}, R1 = 10 \text{ K}, R2 = \infty^{(2)}$		0.15	0.5	A
Deviation of reference input voltage over full temperature range	$I_{\text{ref(dev)}}$	$I_{\text{K}} = 10 \text{ mA}, R1 = 10 \text{ K}, R2 = \infty^{(2)}$ $T_A = \text{full range}$		0.1	0.4	A
Minimum operating current	$I_{\text{K(min)}}$	$V_{\text{KA}} = V_{\text{ref}}^{(1)}$		20	80	A
Off-state cathode current	$I_{\text{K(off)}}$	$V_{\text{KA}} = 6 \text{ V}, V_{\text{ref}} = 0 \text{ V}^{(3)}$ $V_{\text{KA}} = 16 \text{ V}, V_{\text{ref}} = 0 \text{ V}^{(3)}$		0.125 0.135	0.150 0.150	A
Dynamic impedance	$ Z_{\text{KA}} $	$f \leq 1 \text{ kHz}, V_{\text{KA}} = V_{\text{ref}}, I_{\text{K}} = 100 \text{ A to } 100 \text{ mA}^{(1)}$		0.05	0.15	

GM432B (1.0%)

PARAMETER		CONDITION	MIN	TYP	MAX	UNIT
Reference input Voltage	V_{ref}	$V_{\text{KA}} = V_{\text{ref}}, I_{\text{K}} = 10 \text{ mA}, T_A = 25^\circ\text{C}^{(1)}$ $V_{\text{KA}} = V_{\text{ref}}, I_{\text{K}} = 10 \text{ mA}, T_A = 0 \text{ to } +70^\circ\text{C}^{(1)}$	1.228 1.215	1.240	1.252 1.258	V
V_{ref} temp deviation	V_{dev}	$V_{\text{KA}} = V_{\text{ref}}, I_{\text{K}} = 10 \text{ mA}^{(1)}$		10	25	mV
Ratio of change in V_{ref} to change in V_{KA}	$\frac{V_{\text{ref}}}{V_{\text{KA}}}$	$I_{\text{K}} = 10 \text{ mA}, V_{\text{KA}} = 16 \text{ V to } V_{\text{ref}}$	-2.7	-1.0		mV/V
Reference input current	I_{ref}	$I_{\text{K}} = 10 \text{ mA}, R1 = 10 \text{ K}, R2 = \infty^{(2)}$		0.15	0.5	A
Deviation of reference input voltage over full temperature range	$I_{\text{ref(dev)}}$	$I_{\text{K}} = 10 \text{ mA}, R1 = 10 \text{ K}, R2 = \infty^{(2)}$ $T_A = \text{full range}$		0.1	0.4	A
Minimum operating current	$I_{\text{K(min)}}$	$V_{\text{KA}} = V_{\text{ref}}^{(1)}$		20	80	A
Off-state cathode current	$I_{\text{K(off)}}$	$V_{\text{KA}} = 6 \text{ V}, V_{\text{ref}} = 0 \text{ V}^{(3)}$ $V_{\text{KA}} = 16 \text{ V}, V_{\text{ref}} = 0 \text{ V}^{(3)}$		0.125 0.135	0.150 0.150	A
Dynamic impedance	$ Z_{\text{KA}} $	$f \leq 1 \text{ kHz}, V_{\text{KA}} = V_{\text{ref}}, I_{\text{K}} = 100 \text{ A to } 100 \text{ mA}^{(1)}$		0.05	0.15	

NOTES:

- (1) See test circuit 1 on page 4.
 (2) See test circuit 2 on page 4.
 (3) See test circuit 3 on page 4.

1.24V ADJUSTABLE PRECISION SHUNT REGULATORS

◆ ELECTRICAL CHARACTERISTICS ($T_A = 25^\circ\text{C}$ unless otherwise noted)

GM432C (2.0%)

PARAMETER	CONDITION	MIN	TYP	MAX	UNIT
Reference input Voltage	$V_{KA} = V_{ref}$, $I_K = 10\text{ mA}$, $T_A = 25^\circ\text{C}^{(1)}$ $V_{KA} = V_{ref}$, $I_K = 10\text{ mA}$, $T_A = 0\text{ to }+70^\circ\text{C}^{(1)}$	1.215 1.200	1.240	1.265 1.280	V
V_{ref} temp deviation	$V_{KA} = V_{ref}$, $I_K = 10\text{ mA}^{(1)}$		10	35	mV
Ratio of change in V_{ref} to change in V_{KA}	$I_K = 10\text{ mA}$, $V_{KA} = 16\text{V to }V_{ref}$	-2.7	-1.0		mV/V
Reference input current	$I_K = 10\text{ mA}$, $R1 = 10\text{ K}$, $R2 = \infty^{(2)}$		0.15	0.5	A
Deviation of reference input voltage over full temperature range	$I_K = 10\text{ mA}$, $R1 = 10\text{ K}$, $R2 = \infty^{(2)}$ $T_A = \text{full range}$		0.1	0.4	A
Minimum operating current	$V_{KA} = V_{ref}^{(1)}$		20	80	A
Off-state cathode current	$V_{KA} = 6\text{V}$, $V_{ref} = 0\text{V}^{(3)}$ $V_{KA} = 16\text{V}$, $V_{ref} = 0\text{V}^{(3)}$		0.125 0.135	0.150 0.150	A
Dynamic impedance	$f \leq 1\text{ kHz}$, $V_{KA} = V_{ref}$, $I_K = 100\text{ A to }100\text{ mA}^{(1)}$		0.05	0.15	

NOTES:

- (1) See test circuit 1.
- (2) See test circuit 2.
- (3) See test circuit 3.

◆ TEST CIRCUITS

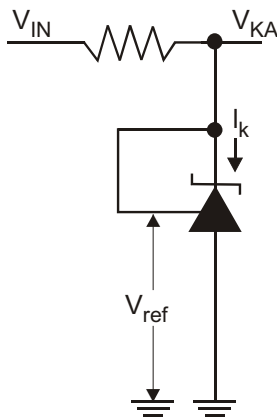

Test Circuit 1
 $V_{KA} = V_{ref}$

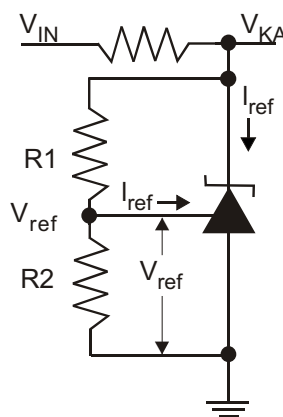

Test Circuit 2
 $V_{KA} > V_{ref}$

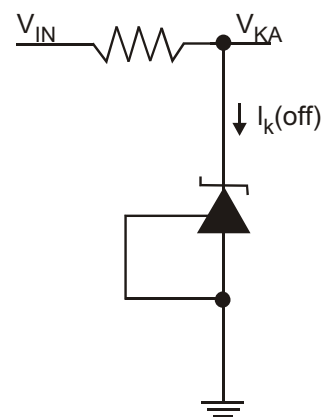

Test Circuit 3
Off-State

1.24V ADJUSTABLE PRECISION SHUNT REGULATORS

◆ TYPICAL APPLICATIONS

GM432A, GM432B

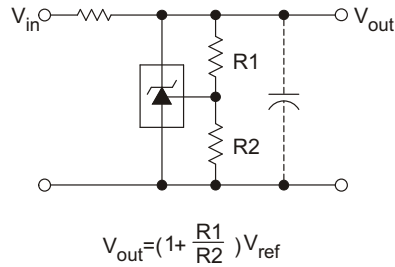

Figure 1. Shunt Regulator

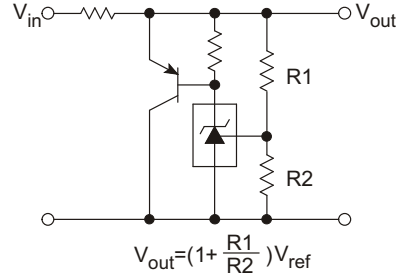

Figure 2. High Current Shunt Regulator

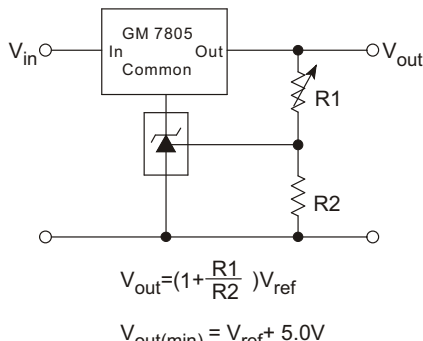

Figure 3. Output Control for a Three Terminal Fixed Regulator

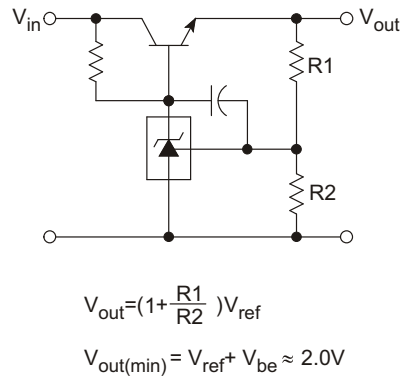

Figure 4. Series Pass Regulator

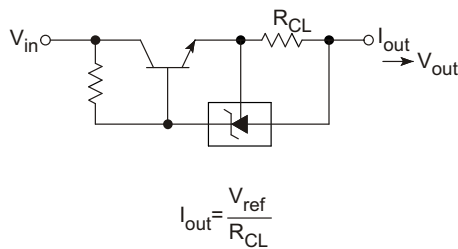

Figure 5. Constant Current Source

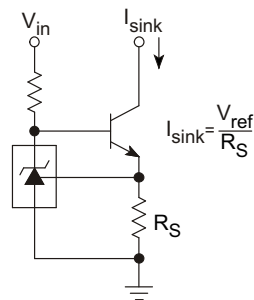

Figure 6. Constant Current Sink

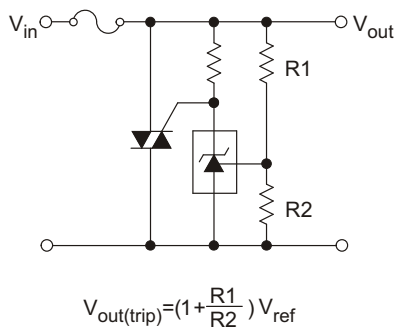

Figure 7. TRIAC Crowbar

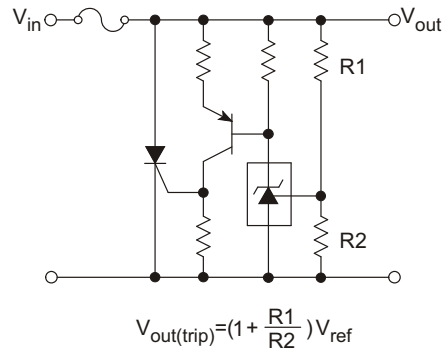
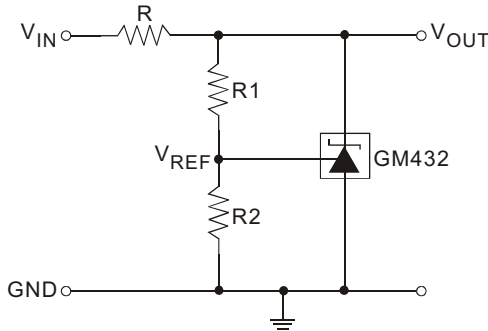

Figure 8. SRC Crowbar

1.24V ADJUSTABLE PRECISION SHUNT REGULATORS

◆ TYPICAL APPLICATION CIRCUIT



Notes:

1. Set V_{OUT} according to the following equation:

$$V_{OUT} = V_{REF} \left(1 + \frac{R1}{R2} \right) + I_{REF} R1$$

2. Choose the value for R as follows:

- ◆ The maximum limit for R should be such that the cathode current, I_K , is greater than the minimum operating current (80µA) at $V_{IN(MIN)}$ *
- ◆ The minimum limit for R should be such that the cathode current, I_K , does not exceed 100mA under all load conditions, and the instantaneous turn-on value for I_K does not exceed 150 mA. Both of the following conditions must be met:

$$R_{min} \geq \frac{V_{IN(max)}}{150mA} \quad (\text{to limit instantaneous turn-on } I_K)$$

$$R_{min} \geq \frac{V_{IN(max)} - V_{OUT}}{I_{OUT(min)} + 100mA} \quad (\text{to limit } I_K \text{ under normal operating conditions})$$

◆ Typical Performance Characteristics

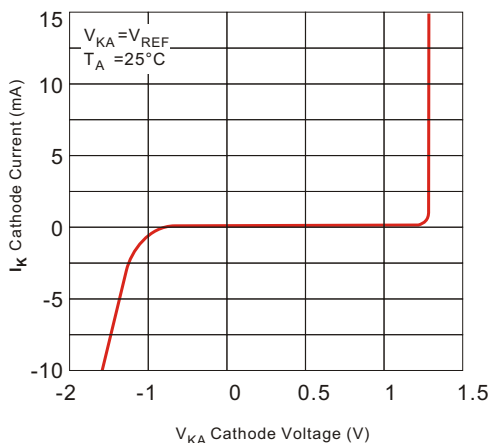

Figure 9. Cathode Current vs. Cathode Voltage

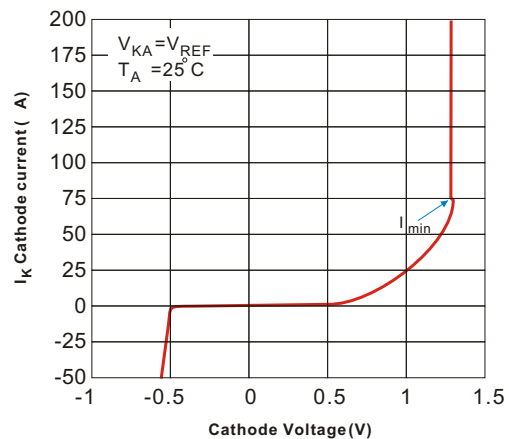

Figure 10. Cathode Current vs. Cathode Voltage

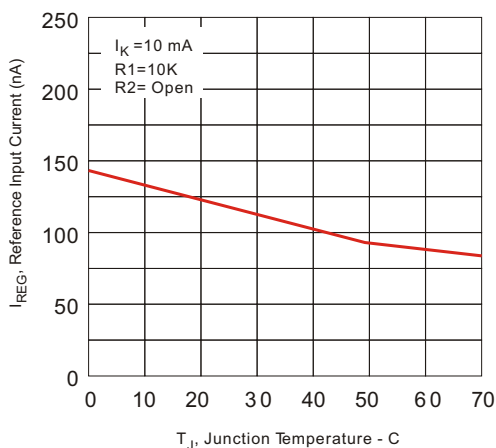

Figure 11. Ref. Voltage vs. Junction Temperature

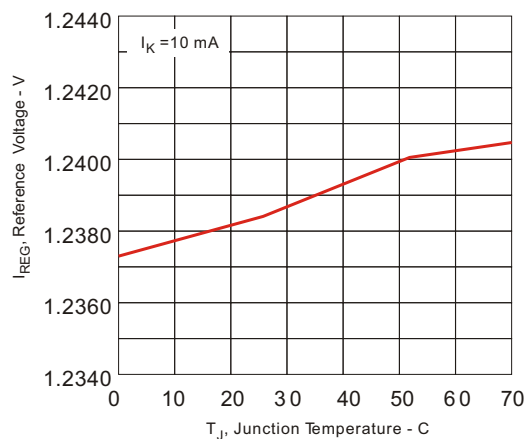
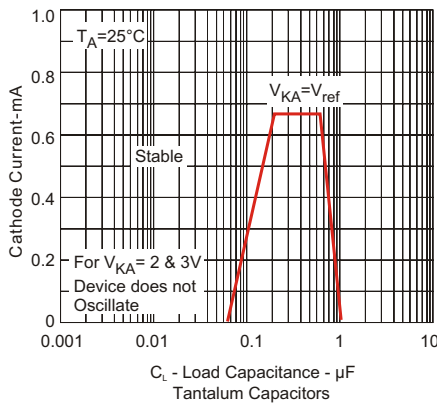
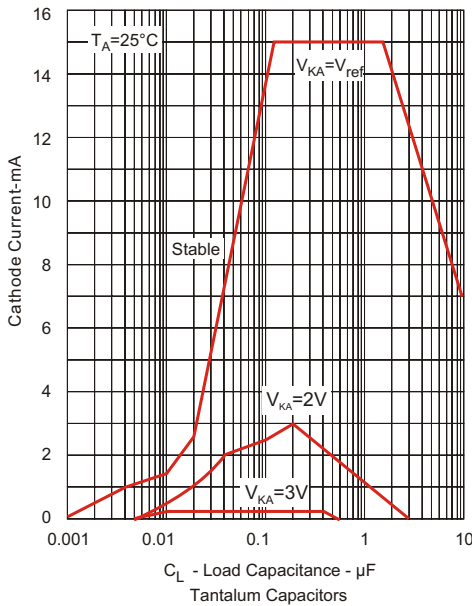

Figure 12. Ref. Input Current vs. Junction Temperature

◆ Stability Boundary Conditions



* Stability boundary condition test shows that tantalum capacitors are recommended to minimize the conditions that may cause the device to oscillate.

A Note About Stability

When using the GM432 as a shunt regulator, you can optimize stability by setting C_L either (1) no load capacitance across the GM432, decouple at the load; or (2) large capacitance across the GM432, optional decoupling at the load. The GM432 can become unstable with capacitances of approximately 10nF to 1μF when cathode currents are less than 3mA or so, with instability increasing as cathode current is reduced. So, while the GM432 is happily stable at, for example, cathode current of 10mA with a 0.1μF capacitor across it, it can oscillate transiently as the cathode current rises through the region of instability. To avoid this problem completely, simply eliminate the capacitor or select a very low or very high (e.g. 10μF) capacitor C_L . Since you will probably want local decoupling at the load, the best idea is to use no capacitance across the device. Just the resistance and capacitance of the PCB traces and vias will prevent local load decoupling from causing transient oscillation during start-up. If you place the GM432 right next to the load, with the load decoupling capacitor directly across it, you must use a capacitor of \leq nF or \leq 10μF.

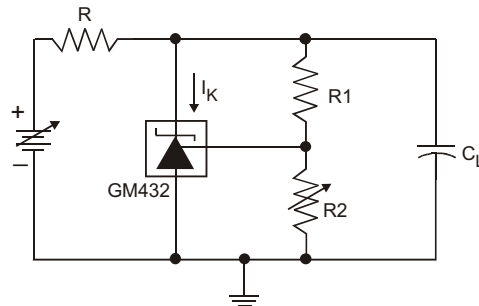

1.24V ADJUSTABLE PRECISION SHUNT REGULATORS

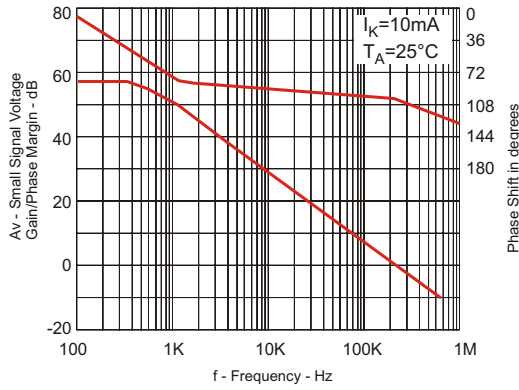

Figure 13. Small Signal Voltage Gain/ Phase Margin vs. Frequency

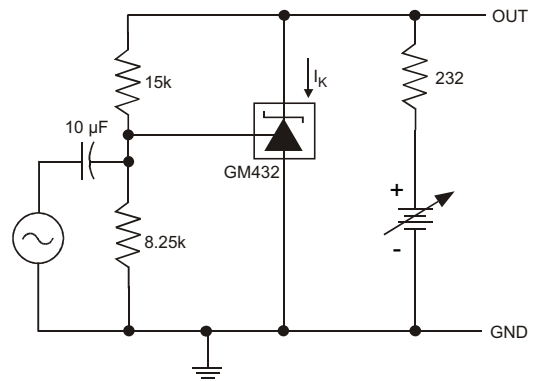
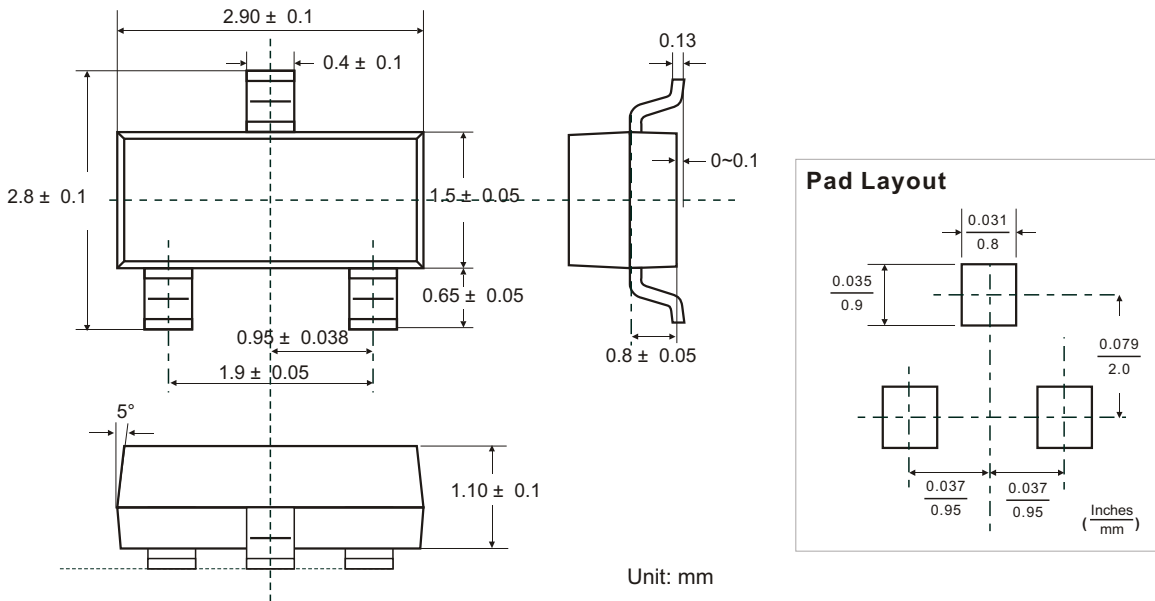

Figure 14. Test Circuit - Small - Signal Gain and Phase

◆ SOT-23 PACKAGE OUTLINE DIMENSIONS



1.24V ADJUSTABLE PRECISION SHUNT REGULATORS

◆ SOT-25(SOT-23-5) PACKAGE OUTLINE DIMENSIONS

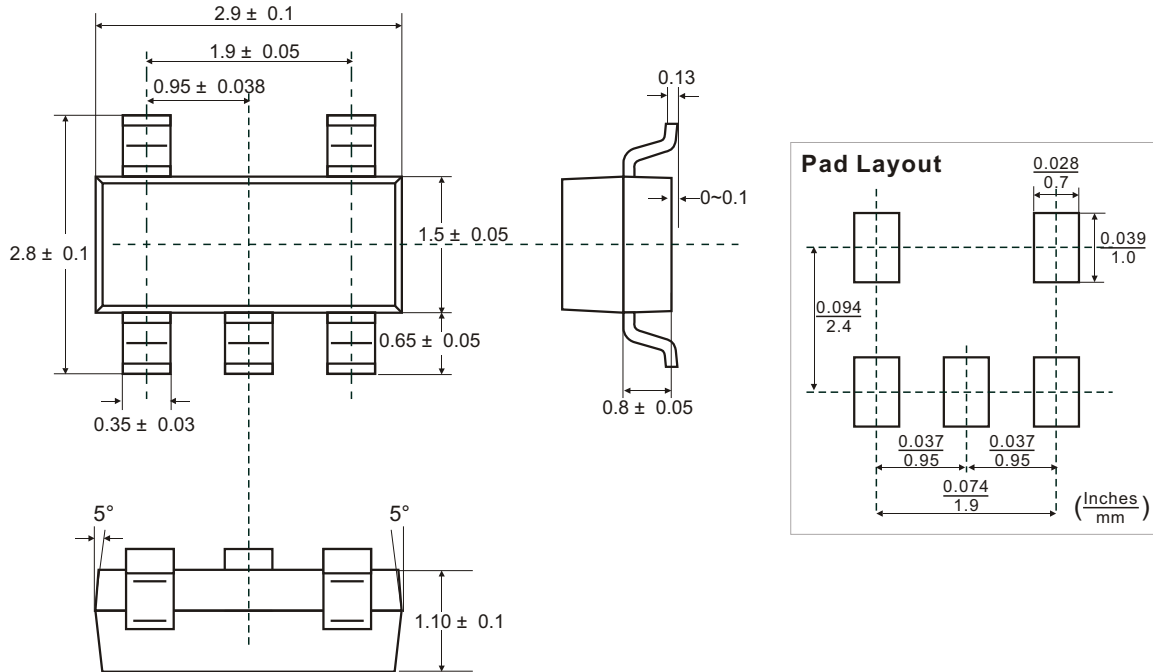

◆ SOP-8 PACKAGE OUTLINE DIMENSIONS

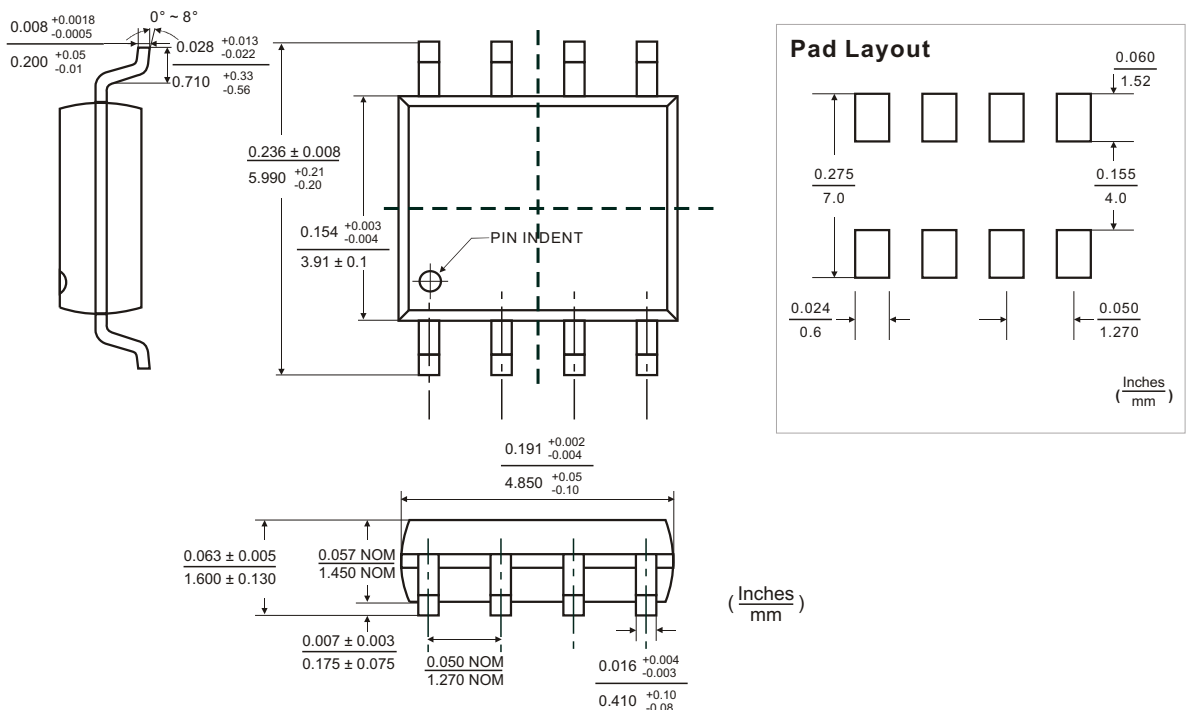

1.24V ADJUSTABLE PRECISION SHUNT REGULATORS

◆ SOT-89 PACKAGE OUTLINE DIMENSIONS

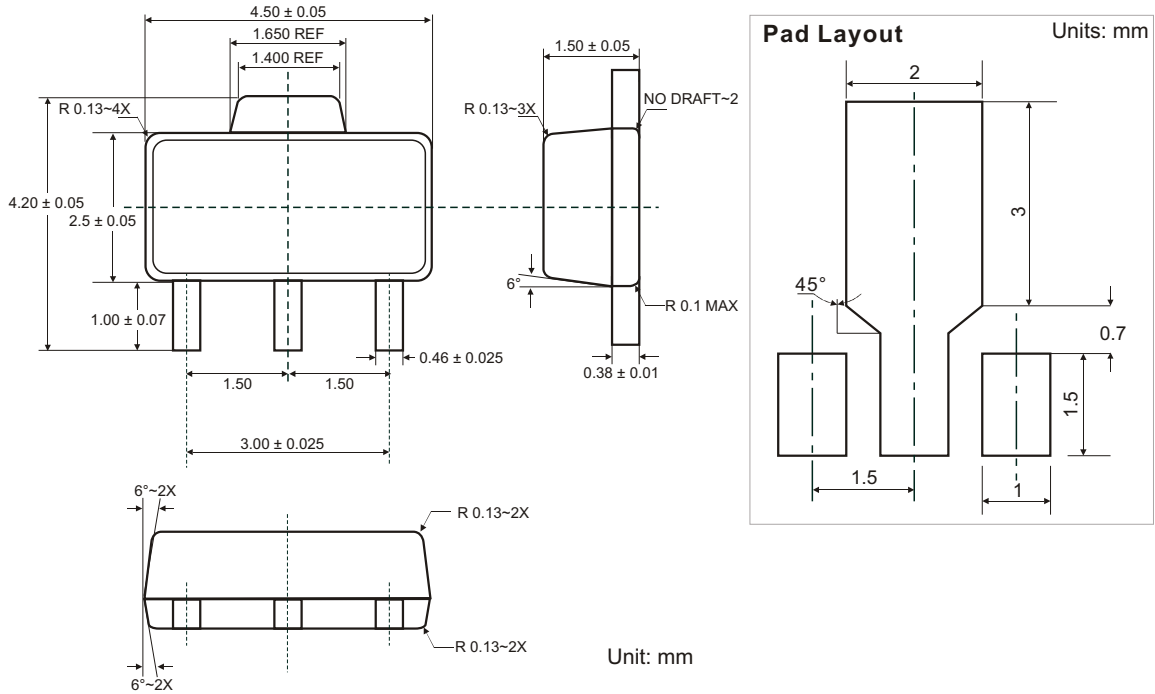

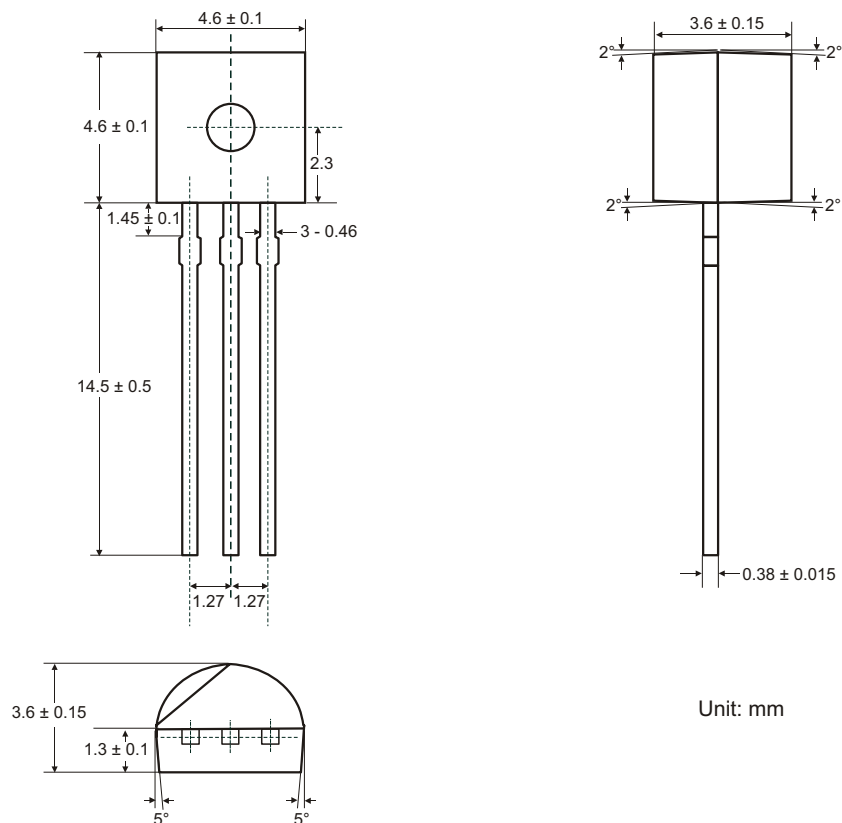

◆ TO-92 PACKAGE OUTLINE DIMENSIONS

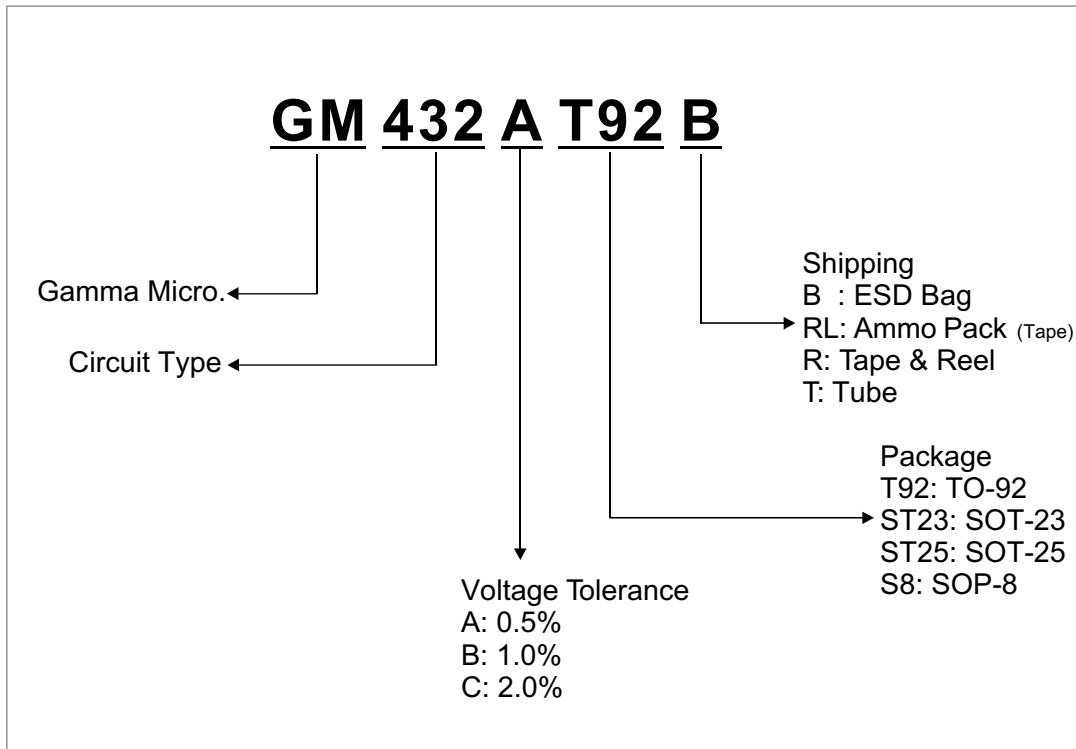

◆ ORDERING NUMBER



1.24V ADJUSTABLE PRECISION SHUNT REGULATORS

GAMMA Micro, , and  are registered trademarks of GAMMA MICROELECTRONICS INC. GAMMA reserves the right to make changes without further notice to any products herein. Information provided herein is alleged to be exact and consistent and this publication surpasses and replaces all information previously supplied.

GAMMA makes no warranty the suitability of its products for any particular purpose, nor does GAMMA assume any liability arising out of the application or use of any product or circuit, and specifically disclaims any and all liability including without limitation special, consequential or incidental damages. GAMMA products are not authorized for using as critical components in life support devices or systems without prior written approval from GAMMA MICROELECTRONICS INC.
