

UT54ACS151/UT54ACTS151

Radiation-Hardened

1 of 8 Data Selectors/Multiplexers

FEATURES

- 8-line to 1-line multiplexers can perform as Boolean function generators, parallel-to-serial converters, and data source selectors
- 1.2μ radiation-hardened CMOS
 - Latchup immune
- High speed
- Low power consumption
- Single 5 volt supply
- Available QML Q or V processes
- Flexible package
 - 16-pin DIP
 - 16-lead flatpack

DESCRIPTION

The UT54ACS151 and the UT54ACTS151 are data multiplexers that provide full binary decoding to select one of eight data sources. The strobe input, \bar{G} , must be at a low logic level to enable the inputs. A high level at the strobe terminal forces the \bar{Y} output high and the Y output low.

The devices are characterized over full military temperature range of -55°C to +125°C.

FUNCTION TABLE

INPUTS				OUTPUT	
SELECT			STROBE	Y	\bar{Y}
C	B	A	\bar{G}		
X	X	X	H	L	H
L	L	L	L	D0	$\bar{D0}$
L	L	H	L	D1	$\bar{D1}$
L	H	L	L	D2	$\bar{D2}$
L	H	H	L	D3	$\bar{D3}$
H	L	L	L	D4	$\bar{D4}$
H	L	H	L	D5	$\bar{D5}$
H	H	L	L	D6	$\bar{D6}$
H	H	H	L	D7	$\bar{D7}$

H= high level, L = low level, X = irrelevant
D0, D1... D7 = the level of the D respective input

PINOUTS

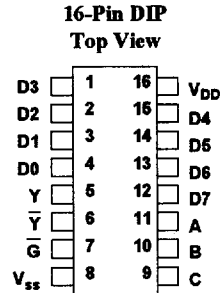

16-Lead Flatpack Top View

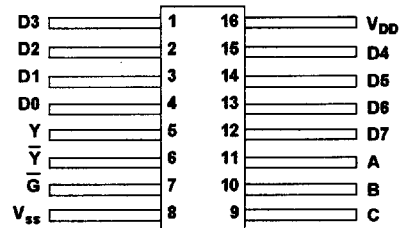

LOGIC SYMBOL

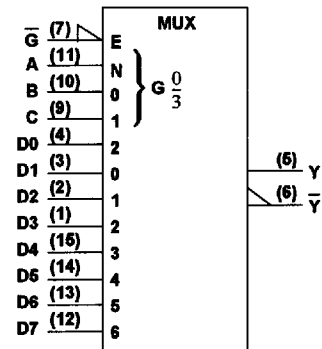

Note:

1. Logic symbol in accordance with ANSI/IEEE Std 91-1984 and IEC Publication 617-12.

LOGIC DIAGRAM

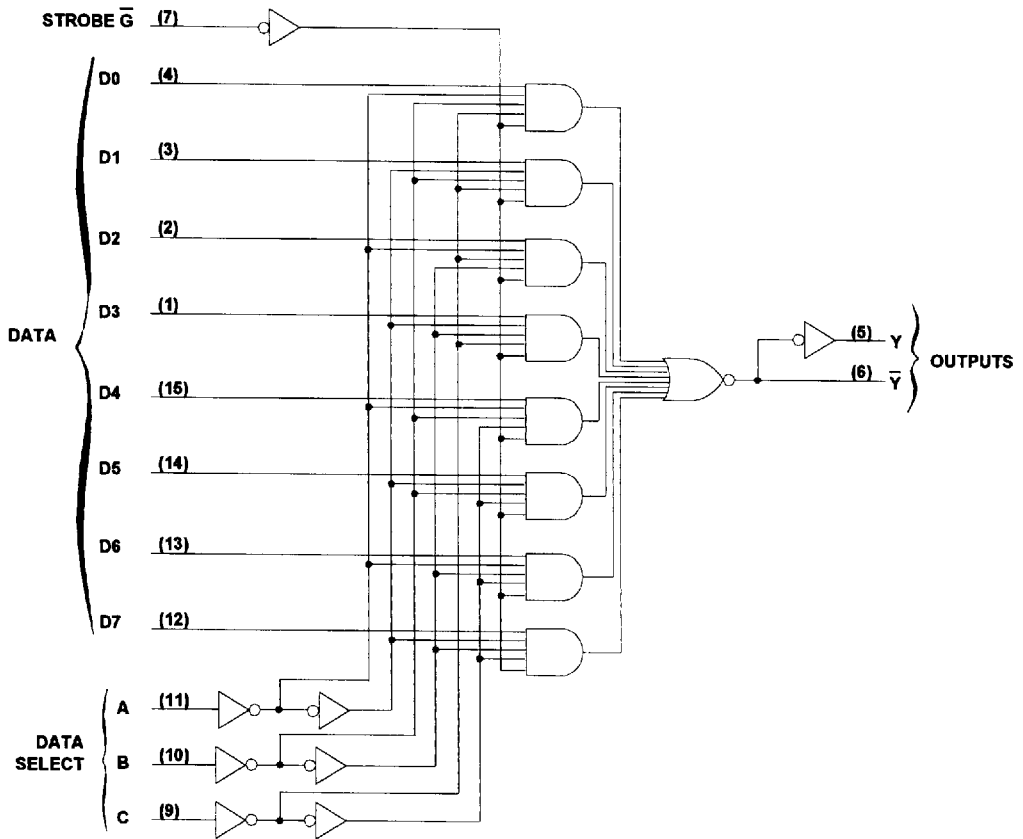

RADIATION HARDNESS SPECIFICATIONS ¹

PARAMETER	LIMIT	UNITS
Total Dose	1.0E6	rads(Si)
SEU Threshold ²	80	MeV-cm ² /mg
SEL Threshold	120	MeV-cm ² /mg
Neutron Fluence	1.0E14	n/cm ²

- Notes:**
 1. Logic will not latchup during radiation exposure within the limits defined in the table.
 2. Device storage elements are immune to SEU affects.

ABSOLUTE MAXIMUM RATINGS

SYMBOL	PARAMETER	LIMIT	UNITS
V _{DD}	Supply voltage	-0.3 to 7.0	V
V _{I/O}	Voltage any pin	-3 to V _{DD} +3	V
T _{STG}	Storage Temperature range	-65 to +150	°C
T _J	Maximum junction temperature	+175	°C
T _{LS}	Lead temperature (soldering 5 seconds)	+300	°C
Θ _{JC}	Thermal resistance junction to case	20	°C/W
I _I	DC input current	±10	mA
P _D	Maximum power dissipation	1	W

- Note:**
 1. Stresses outside the listed absolute maximum ratings may cause permanent damage to the device. This is a stress rating only, functional operation of the device at these or any other conditions beyond limits indicated in the operational sections is not recommended. Exposure to absolute maximum rating conditions for extended periods may affect device reliability.

RECOMMENDED OPERATING CONDITIONS

SYMBOL	PARAMETER	LIMIT	UNITS
V _{DD}	Supply voltage	4.5 to 5.5	V
V _{IN}	Input voltage any pin	0 to V _{DD}	V
T _C	Temperature range	-55 to + 125	°C

DC ELECTRICAL CHARACTERISTICS ⁷(V_{DD} = 5.0V ±10%; V_{SS} = 0V ⁶, -55°C < T_C < +125°C)

SYMBOL	PARAMETER	CONDITION	MIN	MAX	UNIT
V _{IL}	Low-level input voltage ¹ ACTS ACS			0.8 .3V _{DD}	V
V _{IH}	High-level input voltage ¹ ACTS ACS		.5V _{DD} .7V _{DD}		V
I _{IN}	Input leakage current ACTS/ACS	V _{IN} = V _{DD} or V _{SS}	-1	1	μA
V _{OL}	Low-level output voltage ³ ACTS ACS	I _{OL} = 8.0mA I _{OL} = 100μA		0.40 0.25	V
V _{OH}	High-level output voltage ³ ACTS ACS	I _{OH} = -8.0mA I _{OH} = -100μA	.7V _{DD} V _{DD} - 0.25		V
I _{OS}	Short-circuit output current ^{2,4} ACTS/ACS	V _O = V _{DD} and V _{SS}	-200	200	mA
I _{OL}	Output current ¹⁰ (Sink)	V _{IN} = V _{DD} or V _{SS} V _{OL} = 0.4V	8		mA
I _{OH}	Output current ¹⁰ (Source)	V _{IN} = V _{DD} or V _{SS} V _{OH} = V _{DD} - 0.4V	-8		mA
P _{total}	Power dissipation ^{2,8,9}	C _L = 50pF		2.3	mW/ MHz
I _{DDQ}	Quiescent Supply Current	V _{DD} = 5.5V		10	μA
ΔI _{DDQ}	Quiescent Supply Current Delta ACTS	For input under test V _{IN} = V _{DD} - 2.1V For all other inputs V _{IN} = V _{DD} or V _{SS} V _{DD} = 5.5V		1.6	mA
C _{IN}	Input capacitance ⁵	f = 1MHz @ 0V		15	pF
C _{OUT}	Output capacitance ⁵	f = 1MHz @ 0V		15	pF

UT54ACS151/UT54ACTS151

Notes:

1. Functional tests are conducted in accordance with MIL-STD-883 with the following input test conditions: $V_{IH} = V_{IH(min)} + 20\%$, -0% ; $V_{IL} = V_{IL(max)} + 0\%$, -50% , as specified herein, for TTL, CMOS, or Schmitt compatible inputs. Devices may be tested using any input voltage within the above specified range, but are guaranteed to $V_{IH(min)}$ and $V_{IL(max)}$.
2. Supplied as a design limit but not guaranteed or tested.
3. Per MIL-PRF-38535, for current density $\leq 5.0E5$ amps/cm², the maximum product of load capacitance (per output buffer) times frequency should not exceed 3,765 pF/MHz.
4. Not more than one output may be shorted at a time for maximum duration of one second.
5. Capacitance measured for initial qualification and when design changes may affect the value. Capacitance is measured between the designated terminal and V_{SS} at frequency of 1MHz and a signal amplitude of 50mV rms maximum.
6. Maximum allowable relative shift equals 50mV.
7. All specifications valid for radiation dose $\leq 1E6$ rads(Si).
8. Power does not include power contribution of any TTL output sink current.
9. Power dissipation specified per switching output.
10. This value is guaranteed based on characterization data, but not tested.

AC ELECTRICAL CHARACTERISTICS ²(V_{DD} = 5.0V ±10%; V_{SS} = 0V¹, -55°C < T_C < +125°C)

SYMBOL	PARAMETER	MINIMUM	MAXIMUM	UNIT
t _{PHL}	Input to Y	1	22	ns
t _{PLH}	Input to Y	1	23	ns
t _{PHL}	Input to \bar{Y}	1	25	ns
t _{PLH}	Input to \bar{Y}	1	19	ns
t _{PHL}	Select to Y	1	21	ns
t _{PLH}	Select to Y	1	22	ns
t _{PHL}	Select to \bar{Y}	1	24	ns
t _{PLH}	Select to \bar{Y}	1	21	ns
t _{PHL}	\bar{G} to Y	1	14	ns
t _{PLH}	\bar{G} to Y	1	11	ns
t _{PHL}	\bar{G} to \bar{Y}	1	14	ns
t _{PLH}	\bar{G} to \bar{Y}	1	10	ns

Notes:

1. Maximum allowable relative shift equals 50mV.
2. All specifications valid for radiation dose ≤ 1E6 rads(Si).

Flatpack Packages

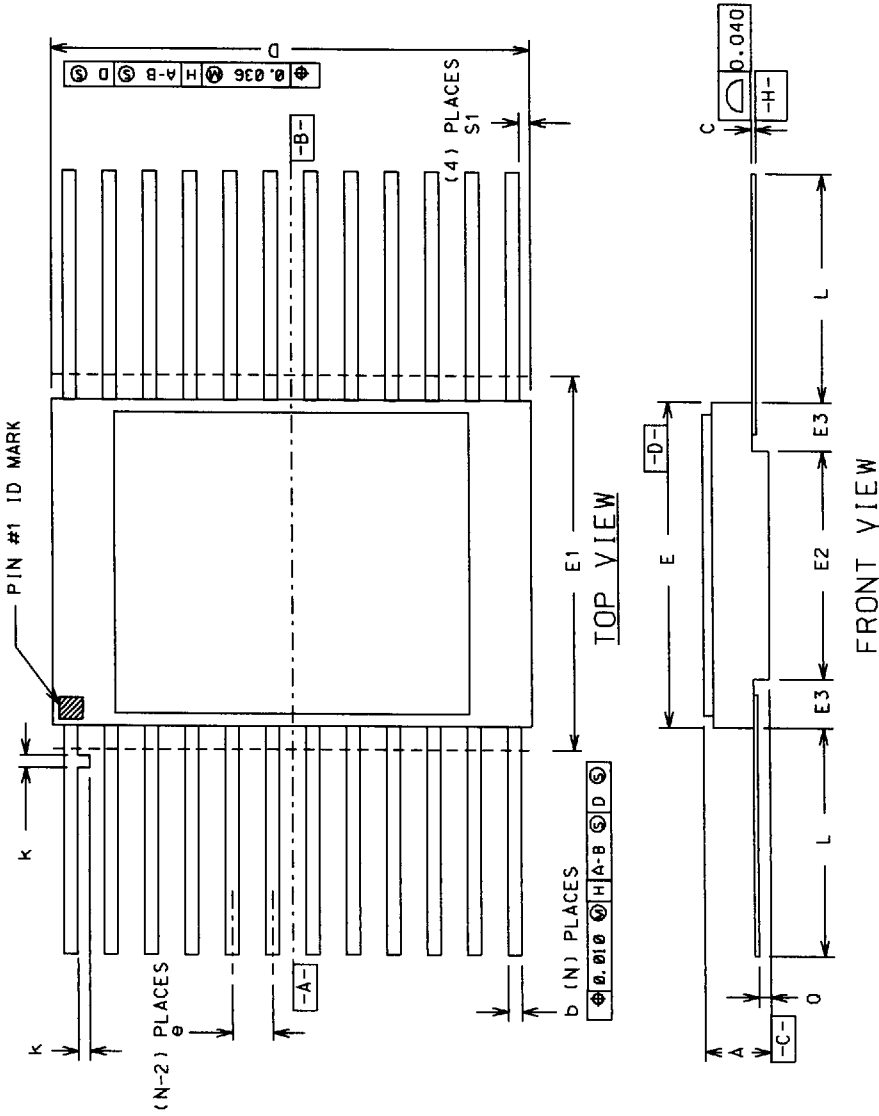

PKG CONF G	LEAD COUNT	MIL-STD 1835 DMG CONF B	DIMENSION SYMBOLS													
			A	b	c	D	E	E1	E2	E3	e	k	L	Q	S1	
-03	14	F-2A	0.115 0.045	0.022 0.015	0.009 0.004	0.390 ---	0.260 0.235	0.290 ---	0.130 ---	0.030 ---	0.050 BSC	0.015 0.008	0.370 0.270	0.045 0.026	---	0.005
-04	16	F-5A	0.115 0.045	0.022 0.015	0.009 0.004	0.440 ---	0.285 0.245	0.315 ---	0.130 ---	0.030 ---	0.050 BSC	0.015 0.008	0.370 0.250	0.045 0.026	---	0.005
-05	20	F-9A	0.115 0.045	0.022 0.015	0.009 0.004	0.540 ---	0.300 0.245	0.330 ---	0.130 ---	0.030 ---	0.050 BSC	0.015 0.008	0.370 0.250	0.045 0.026	---	0.000