

Advanced Information

- 1 048 576 words by 8-bit organization
- Fast access and cycle time
 - 60 ns access time
 - 110 ns cycle time (-60 version)
 - 70 ns access time
 - 130 ns cycle time (-70 version)
 - 80 ns access time
 - 150 ns cycle time (-80 version)
- Fast page mode capability with
 - 45 ns cycle time (-60/-70 version)
 - 50 ns cycle time (-80 version)
- Single + 5 V ($\pm 10\%$) supply
- Low power dissipation
 - max. 1200 mW active (-60 version)
 - max. 1100 mW active (-70 version)
 - max. 940 mW active (-80 version)
 - CMOS – 11 mW standby
 - TTL – 22 mW standby
- $\overline{\text{CAS}}$ -before- $\overline{\text{RAS}}$ refresh, $\overline{\text{RAS}}$ -only-refresh, Hidden refresh
- 2 decoupling capacitors mounted on substrate
- All inputs, outputs and clocks fully TTL compatible
- Single in-Line Memory Module socket version, with 15.24 mm height
- Pin configuration according to JEDEC standards
- Utilizes two 1Mx4-DRAMs in SOJ package
- 1024 refresh cycles / 16 ms

The HYM 22100S-60/-70/-80 is a 1 Mbyte RAM module organized as 1 048 576 words by 8-bit in a 30-pin single-in-line package comprising two HYB 514400BJ 1 M × 4 DRAMs in SOJ-packages mounted together with two 0.2 μF multilayer ceramic decoupling capacitors on a PC board.

The HYB 514400BJ is described in the data sheet and is fully electrical tested and processed according to Siemens standard quality procedure prior to module assembly. After assembly onto the board, a further set of electrical tests is performed.

The common I/O feature on the HYM 22100S-60/-70/-80 dictates the use of early write cycles.

Ordering Information

Type	Ordering Code	Package	Descriptions
HYM 22100S-60	on request	L-SIM-30-1	DRAM Module (access time 60 ns)
HYM 22100S-70	Q67100-Q649	L-SIM-30-1	DRAM Module (access time 70 ns)
HYM 22100S-80	Q67100-Q650	L-SIM-30-1	DRAM Module (access time 80 ns)

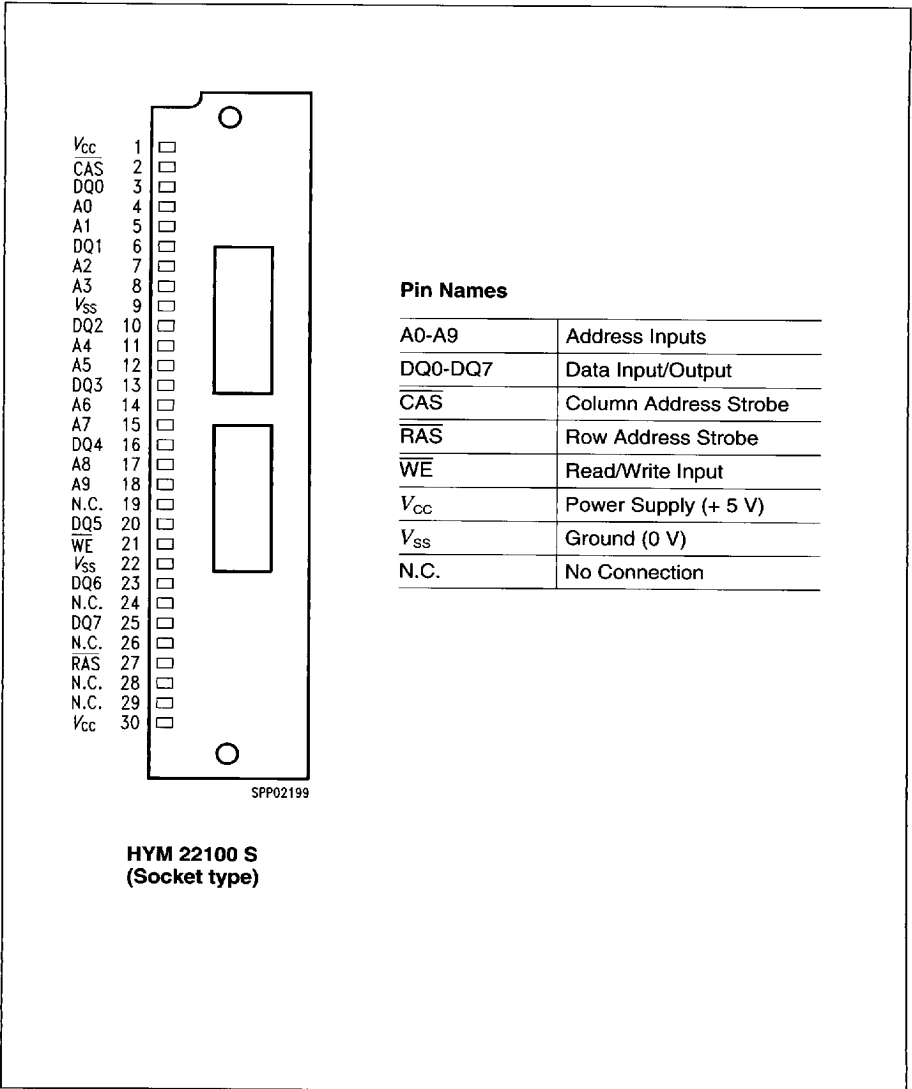

Pin Names

A0-A9	Address Inputs
DQ0-DQ7	Data Input/Output
CAS	Column Address Strobe
RAS	Row Address Strobe
WE	Read/Write Input
V _{CC}	Power Supply (+ 5 V)
V _{SS}	Ground (0 V)
N.C.	No Connection

Pin Configuration

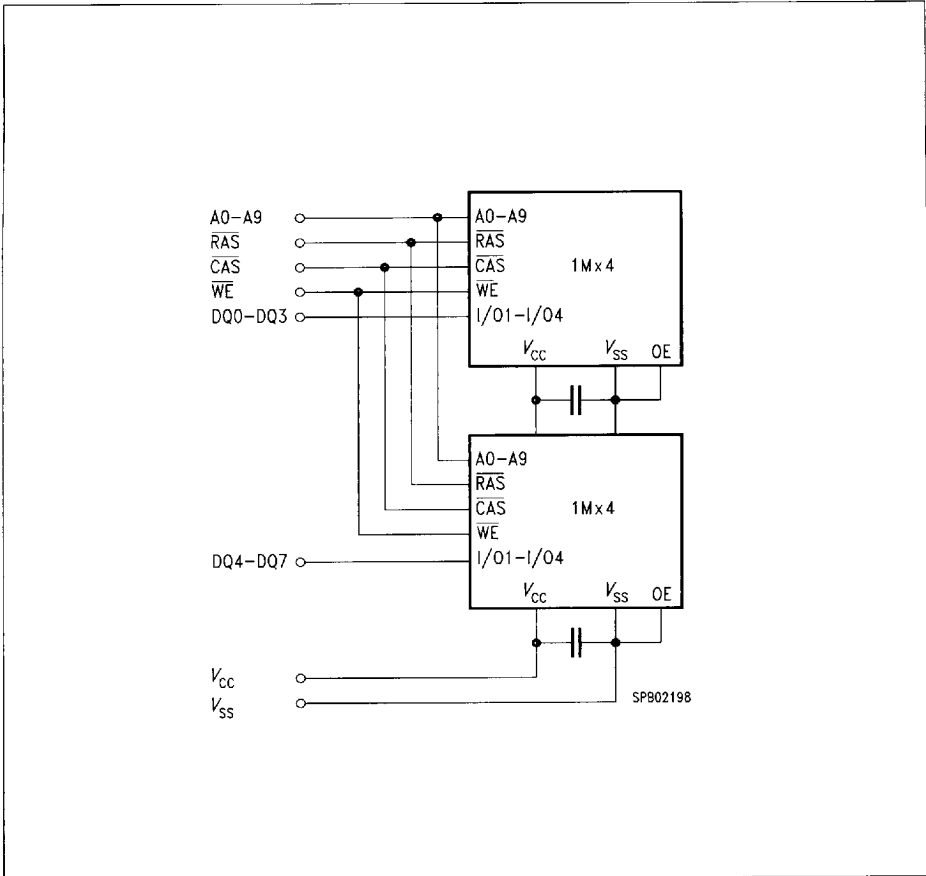

Block Diagram

Absolute Maximum Ratings

Operating temperature range	0 to + 70 °C
Storage temperature range.....	- 55 to + 125 °C
Soldering temperature	260 °C
Soldering time	10 s
Input/output voltage	- 1 to + 7 V
Power supply voltage.....	- 1 to + 7 V
Power dissipation.....	1.54 W
Data out current (short circuit)	50 mA

Note: Stresses above those listed under "Absolute Maximum Ratings" may cause permanent damage to the device. Exposure to absolute maximum rating conditions for extended periods may affect device reliability.

DC Characteristics ¹⁾

$T_A = 0$ to 70 °C; $V_{CC} = 5$ V \pm 10 %

Parameter	Symbol	Limit Values		Unit	Test Condition
		min.	max.		
Input high voltage	V_{IH}	2.4	6.5	V	—
Input low voltage	V_{IL}	- 1.0	0.8	V	—
Output high voltage ($I_{OUT} = - 5$ mA)	V_{OH}	2.4	—	V	—
Output low voltage ($I_{OUT} = 4.2$ mA)	V_{OL}	—	0.4	V	—
Input leakage current (0 V < V_{IN} < 6.5 V, all other pins = 0 V)	$I_{I(L)}$	- 10	10	μ A	—
Output leakage current (DO is disabled, 0 V < V_{OUT} < 5.5 V)	$I_{O(L)}$	- 10	10	μ A	—
Average V_{CC} supply current: HYM 22100S-60 HYM 22100S-70 HYM 22100S-80 (\overline{RAS} , \overline{CAS} , address cycling, $t_{RC} = t_{RC}$ min.)	I_{CC1}	—	220 200 170	mA mA mA	^{2) 3)}
Standby V_{CC} supply current ($\overline{RAS} = \overline{CAS} = V_{IH}$)	I_{CC2}	—	4	mA	—
Average V_{CC} supply current during \overline{RAS} only refresh cycles: HYM 22100S-60 HYM 22100S-70 HYM 22100S-80 (\overline{RAS} cycling, $\overline{CAS} = V_{IH}$, $t_{RC} = t_{RC}$ min.)	I_{CC3}	—	220 200 170	mA mA mA	²⁾

Notes see page 309.

DC Characteristics ¹⁾ (cont'd)

Parameter	Symbol	Limit Values		Unit	Test Condition
		min.	max.		
Average V_{CC} supply current during fast page mode: HYM 22100S-60 HYM 22100S-70 HYM 22100S-80 ($\overline{RAS} = V_{IL}$, \overline{CAS} , address cycling, $t_{PC} = t_{PC \text{ min.}}$)	I_{CC4}	— — —	140 120 100	mA mA mA	2), 3)
Standby V_{CC} supply current ($\overline{RAS} = \overline{CAS} = V_{CC} = -0.2 \text{ V}$)	I_{CC5}	—	2	mA	—
Average V_{CC} supply current during \overline{CAS} -before- \overline{RAS} refresh mode: HYM 22100S-60 HYM 22100S-70 HYM 22100S-80 (\overline{RAS} , \overline{CAS} cycling, $t_{RC} = t_{RC \text{ min.}}$)	I_{CC6}	— — —	220 200 170	mA mA mA	2)

Notes see page 309.

Capacitance

$T_A = 0 \text{ to } 70 \text{ }^\circ\text{C}$; $V_{CC} = 5 \text{ V} \pm 10 \%$; $f = 1 \text{ MHz}$

Parameter	Symbol	Limit Values		Unit
		min.	max.	
Input capacitance (A0 to A9, \overline{RAS} , \overline{CAS} , \overline{WE})	C_{I1}	—	30	pF
I/O capacitance (DQ0 to DQ7)	C_{I0}	—	15	pF

AC Characteristics ^{4) 5)}

$T_A = 0$ to 70 °C; $V_{CC} = 5$ V \pm 10 %; $t_T = 5$ ns

Parameter	Symbol	Limit Values						Unit
		-60		-70		-80		
		min.	max.	min.	max.	min.	max.	
Random read or write cycle time	t_{RC}	110	–	130	–	150	–	ns
Fast page mode cycle time	t_{PC}	45	–	45	–	50	–	ns
Access time from \overline{RAS} ^{6) 11) 12)}	t_{RAC}	–	60	–	70	–	80	ns
Access time from \overline{CAS} ^{6) 11)}	t_{CAC}	–	20	–	20	–	20	ns
Access time from column address ^{6) 12)}	t_{AA}	–	30	–	35	–	40	ns
Access time from \overline{CAS} precharge ⁶⁾	t_{CPA}	–	40	–	40	–	45	ns
\overline{CAS} to output in low-Z ⁶⁾	t_{CLZ}	0	–	0	–	0	–	ns
Output buffer turn-off delay ⁷⁾	t_{OFF}	0	20	0	20	0	20	ns
Transition time (rise and fall) ⁵⁾	t_T	3	50	3	50	3	50	ns
\overline{RAS} precharge time	t_{RP}	40	–	50	–	60	–	ns
\overline{RAS} pulse width	t_{RAS}	60	10000	70	10000	80	10000	ns
\overline{RAS} pulse width (fast page mode)	t_{RASP}	60	100000	70	100000	80	100000	ns
\overline{RAS} hold time	t_{RSH}	20	–	20	–	20	–	ns
\overline{CAS} hold time	t_{CSH}	60	–	70	–	80	–	ns
\overline{CAS} pulse width	t_{CAS}	20	10000	20	10000	20	10000	ns
\overline{RAS} to \overline{CAS} delay time ¹¹⁾	t_{RCD}	20	40	20	50	20	60	ns
\overline{RAS} to column address delay time ¹²⁾	t_{RAD}	15	30	15	35	15	40	ns
\overline{CAS} to \overline{RAS} precharge time	t_{CRP}	5	–	5	–	5	–	ns
\overline{CAS} precharge time (fast page mode)	t_{CP}	10	–	10	–	10	–	ns
Row address setup time	t_{ASR}	0	–	0	–	0	–	ns
Row address hold time	t_{RAH}	10	–	10	–	10	–	ns
Column address setup time	t_{ASC}	0	–	0	–	0	–	ns
Column address hold time	t_{CAH}	15	–	15	–	15	–	ns

Notes see page 309.

AC Characteristics ^{4) 5)} (cont'd)

$T_A = 0$ to 70 °C; $V_{CC} = 5$ V \pm 10 %; $t_r = 5$ ns

Parameter	Symbol	Limit Values						Unit
		-60		-70		-80		
		min.	max.	min.	max.	min.	max.	
Column address hold time ref. to RAS	t_{AR}	50	–	55	–	60	–	ns
Column address to RAS lead time	t_{RAL}	30	–	35	–	40	–	ns
Read command setup time	t_{RCS}	0	–	0	–	0	–	ns
Read command hold time ⁸⁾	t_{RCH}	0	–	0	–	0	–	ns
Read command hold time ref. to RAS ⁸⁾	t_{RRH}	0	–	0	–	0	–	ns
Write command hold time	t_{WCH}	10	–	15	–	15	–	ns
Write command hold time ref. to RAS	t_{WCR}	45	–	55	–	60	–	ns
Write command pulse width	t_{WP}	10	–	15	–	15	–	ns
Write command to RAS lead time	t_{RWL}	20	–	20	–	20	–	ns
Write command to CAS lead time	t_{CWL}	20	–	20	–	20	–	ns
Data setup time ⁹⁾	t_{DS}	0	–	0	–	0	–	ns
Data hold time ⁹⁾	t_{DH}	15	–	15	–	15	–	ns
Data hold time ref. to RAS	t_{DHR}	50	–	55	–	60	–	ns
Refresh period	t_{REF}	–	16	–	16	–	16	ms
Write command setup time ¹⁰⁾	t_{WCS}	0	–	0	–	0	–	ns
CAS setup time ¹³⁾	t_{CSR}	5	–	5	–	5	–	ns
CAS hold time ¹³⁾	t_{CHR}	15	–	15	–	15	–	ns
RAS to CAS precharge time	t_{RPC}	0	–	0	–	0	–	ns
CAS precharge time ¹³⁾	t_{CPN}	10	–	10	–	10	–	ns
Write to RAS precharge time ¹³⁾	t_{WRP}	10	–	10	–	10	–	ns
Write hold time ref. to RAS ¹³⁾	t_{WRH}	10	–	10	–	10	–	ns

Notes see page 309.

Waveforms see page 391.

Notes for pages 305 to 308:

- 1) All voltages are referenced to V_{SS} .
- 2) I_{CC1} , I_{CC3} , I_{CC4} and I_{CC6} depend on cycle rate.
- 3) I_{CC1} and I_{CC4} depend on output loading. Specified values are measured with the output open.
- 4) An initial pause of 200 μ s is required after power-up followed by 8 \overline{RAS} cycles out of which at least one cycle has to be a refresh cycle before proper device operation is achieved. In case of using internal refresh counter, a minimum of 8 CAS-before-RAS initialization cycles instead of 8 RAS cycles are required.
- 5) V_{IH} (min.) and V_{IL} (max.) are reference levels for measuring timing of input signals. Transition times are also measured between V_{IH} and V_{IL} .
- 6) Measured with a load equivalent of 2 TTL loads and 100 pF.
- 7) t_{OFF} (max.) defines the time at which the output achieves the open-circuit condition and is not referenced to output voltage levels.
- 8) Either t_{RCH} or t_{RRH} must be satisfied for a read cycle.
- 9) These parameters are referenced to the \overline{CAS} leading edge.
- 10) t_{WCS} is not a restrictive operating parameter. This is included in the datasheet as electrical characteristic only. If $t_{WCS} > t_{WCS}(\text{min.})$, the cycles is an early write cycle and data out pin will remain open circuit (high impedance).
- 11) Operation within the $t_{RCD}(\text{max.})$ limit insures that $t_{RAC}(\text{max.})$ can be met. $t_{RCD}(\text{max.})$ is specified as a reference point only. If t_{RCD} is greater than the specified $t_{RCD}(\text{max.})$ limit, then accesses time is controlled by t_{CAC} .
- 12) Operation within the $t_{RAD}(\text{max.})$ limit insures that $t_{RAC}(\text{max.})$ can be met. $t_{RAD}(\text{max.})$ is specified as a reference point only. If t_{RAD} is greater than the specified $t_{RAD}(\text{max.})$ limit, then accesses time is controlled by t_{AA} .
- 13) For \overline{CAS} -before- \overline{RAS} cycles only.