

Philips Components

Document No.	853-0656
ECN No.	99799
Date of Issue	June 14, 1990
Status	Product Specification
ECL Products	

10123 Bus Driver

Triple 4-3-3-Input Bus Driver

FEATURES

- Typical propagation delay: 3.0ns
- Typical supply current ($-I_{EE}$): 71mA

DESCRIPTION

The 10123 consists of three NOR Gates for use as Drivers. Each can drive a bus with characteristic impedance of not less than 25Ω , such as the case of a bus terminated at both ends in 50Ω . When the output is Low it presents a high impedance to the bus so that its characteristic impedance is not reduced. All unused inputs can be left open due to integrated pull-down resistors which avoid the need for a supply voltage.

ORDERING INFORMATION

DESCRIPTION	ORDER CODE
16-Pin Plastic DIP	10123N
16-Pin Ceramic DIP	10123F

PIN DESCRIPTION

PINS	DESCRIPTION
$D_0 - D_9$	Data Inputs
$\bar{Q}_0 - \bar{Q}_2$	Data Outputs

PIN CONFIGURATION

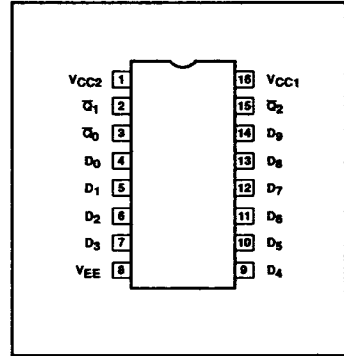

LOGIC DIAGRAM

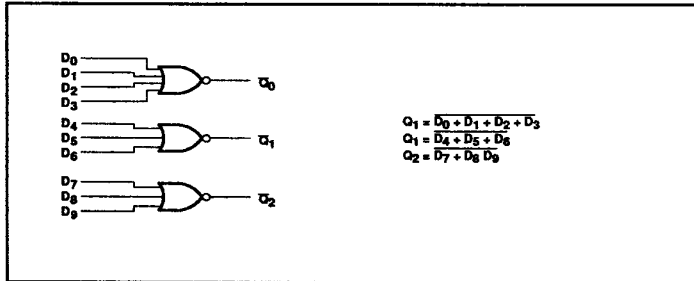

Bus Driver

10123

SIMPLIFIED SCHEMATIC

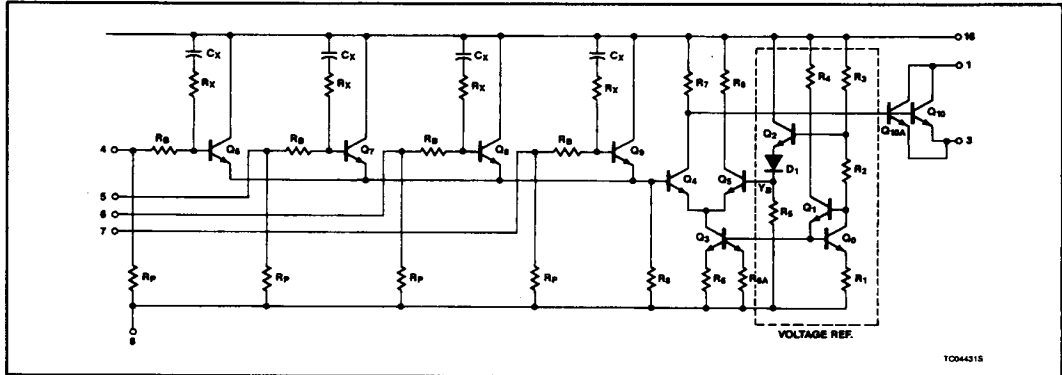

ABSOLUTE MAXIMUM RATINGS

SYMBOL	PARAMETER	LIMITS	UNIT	
V_{EE}	Supply voltage	-8.0	V	
V_{IN}	Input voltage (V_{IN} should never be more negative than V_{EE})	0 to V_{EE}	V	
I_O	Output source current (continuous)	-50	mA	
T_S	Storage temperature range	-55 to +150	°C	
T_J	Maximum junction temperature	Ceramic Package	+165	°C
		Plastic Package	+150	°C

NOTE:

Operation beyond the limits set forth in this table may impair the useful life of the device. Unless otherwise noted, these limits are specified over the operating ambient temperature range.

Bus Driver**10123****DC OPERATING CONDITIONS**

SYMBOL	PARAMETER	TEST CONDITIONS	LIMITS			UNIT
			MIN.	NOM.	MAX.	
V_{CC1}, V_{CC2}	Circuit ground		0	0	0	V
V_{EE}	Supply voltage (negative)			-5.2		V
V_{IH}	High level input voltage	$T_A = -30^\circ\text{C}$			-890	mV
		$T_A = +25^\circ\text{C}$			-810	mV
		$T_A = +85^\circ\text{C}$			-700	mV
V_{IHT}	High level input threshold voltage	$T_A = -30^\circ\text{C}$	-1205			mV
		$T_A = +25^\circ\text{C}$	-1105			mV
		$T_A = +85^\circ\text{C}$	-1035			mV
V_{ILT}	Low level input threshold voltage	$T_A = -30^\circ\text{C}$			-1500	mV
		$T_A = +25^\circ\text{C}$			-1475	mV
		$T_A = +85^\circ\text{C}$			-1440	mV
V_{IL}	Low level input voltage	$T_A = -30^\circ\text{C}$	-1890			mV
		$T_A = +25^\circ\text{C}$	-1850			mV
		$T_A = +85^\circ\text{C}$	-1825			mV
T_A	Operating ambient temperature range		-30	+25	+85	$^\circ\text{C}$

NOTE:When operating at other than the specified V_{EE} voltage (-5.2V), the DC and AC Electrical Characteristics will vary slightly from specified values.

Bus Driver

10123

DC ELECTRICAL CHARACTERISTICS $V_{CC1} = V_{CC2} = \text{ground}$, $V_{EE} = -5.2V \pm 0.010V$, $T_A = -30^\circ\text{C}$ to $+85^\circ\text{C}$ output loading with 25Ω to $-2.1V \pm 0.010V$ unless otherwise specified^{1,3}

SYMBOL	PARAMETER	TEST CONDITIONS ²	LIMITS			UNIT
			MIN.	TYP.	MAX.	
V_{OH}	High level output voltage	$T_A = -30^\circ\text{C}$	-1060		-890	mV
		$T_A = +25^\circ\text{C}$	-960		-810	mV
		$T_A = +85^\circ\text{C}$	-890		-700	mV
V_{OHT}	High level output threshold voltage	$T_A = -30^\circ\text{C}$	-1080			mV
		$T_A = +25^\circ\text{C}$	-980			mV
		$T_A = +85^\circ\text{C}$	-910			mV
V_{OLT}	Low level output threshold voltage	$T_A = -30^\circ\text{C}$			-2010	mV
		$T_A = +25^\circ\text{C}$			-2010	mV
		$T_A = +85^\circ\text{C}$			-2010	mV
V_{OL}	Low level output voltage	$T_A = -30^\circ\text{C}$	-2100		-2030	mV
		$T_A = +25^\circ\text{C}$	-2100		-2030	mV
		$T_A = +85^\circ\text{C}$	-2100		-2030	mV
I_{IH}	High level input current	$T_A = -30^\circ\text{C}$			350	μA
		$T_A = +25^\circ\text{C}$			220	μA
		$T_A = +85^\circ\text{C}$			220	μA
I_{IL}	Low level input current	$T_A = -30^\circ\text{C}$	0.5			μA
		$T_A = +25^\circ\text{C}$	0.5			μA
		$T_A = +85^\circ\text{C}$	0.3			μA
$-I_{EE}$	V_{EE} supply current	$T_A = -30^\circ\text{C}$			82	mA
		$T_A = +25^\circ\text{C}$		71	75	mA
		$T_A = +85^\circ\text{C}$			82	mA
$\frac{\Delta V_{OH}}{\Delta V_{EE}}$	High level output voltage compensation	$T_A = +25^\circ\text{C}$		0.016		V/V
$\frac{\Delta V_{OL}}{\Delta V_{EE}}$	Low level output voltage compensation			0.250		V/V
$\frac{\Delta V_{BB}}{\Delta V_{EE}}$	Reference bias voltage compensation			0.148		V/V

NOTES:

- The specified limits represent the worst case values for the parameter. Since these worst case values normally occur at the supply voltage and temperature extremes, additional noise immunity can be achieved by decreasing the allowable operating condition ranges.
- Conditions for testing shown in the tables are not necessarily worst case. For worst case testing guidelines, refer to DC Testing, Chapter 1, Section 3.
- The specified limits shown in the DC Electrical Characteristics table can be met only after thermal equilibrium has been established. Thermal equilibrium is established by applying power for at least 2 minutes, while maintaining transverse airflow of 2.5 meters/sec (500 linear feet/min) over the device, mounted either in a test socket or on a printed circuit board. Test voltage values are given in the DC Operating Conditions table.

Bus Driver

10123

AC ELECTRICAL CHARACTERISTICS $V_{CC1} = V_{CC2} = \text{ground}, V_{EE} = -5.2V \pm 0.010V$

SYMBOL	PARAMETER	TEST CONDITION	LIMITS						UNIT	
			$T_A = -30^\circ\text{C}$		$T_A = +25^\circ\text{C}$			$T_A = +85^\circ\text{C}$		
			MIN.	MAX.	MIN.	TYP.	MAX.	MIN.		MAX.
t_{PLH} t_{PHL}	Propagation delay D_n to \bar{Q}_n	Waveform 1	1.20	4.60	1.20	3.00	4.40	1.20	4.80	ns
t_{TLH} t_{THL}	Transition time 20% to 80%, 80% to 20%	Waveform 1	1.00	3.70	1.00	2.50	3.50	1.00	3.90	ns

NOTE:

For AC test setup information, see AC Testing, Chapter 2, Section 3.

AC WAVEFORMS

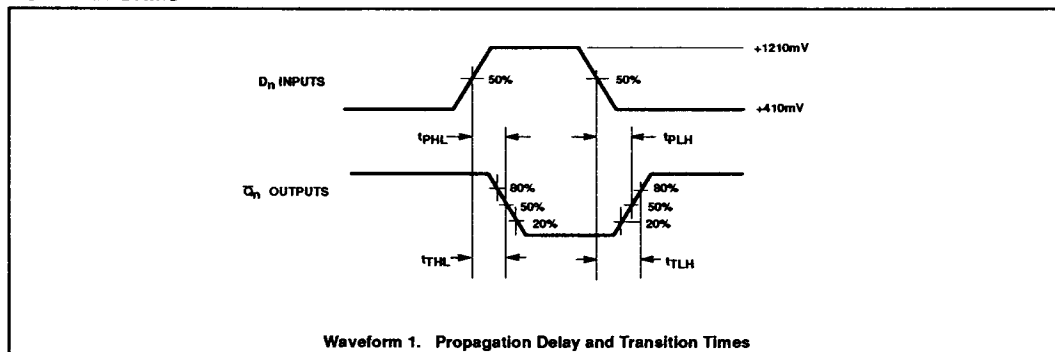

AC TEST CIRCUIT

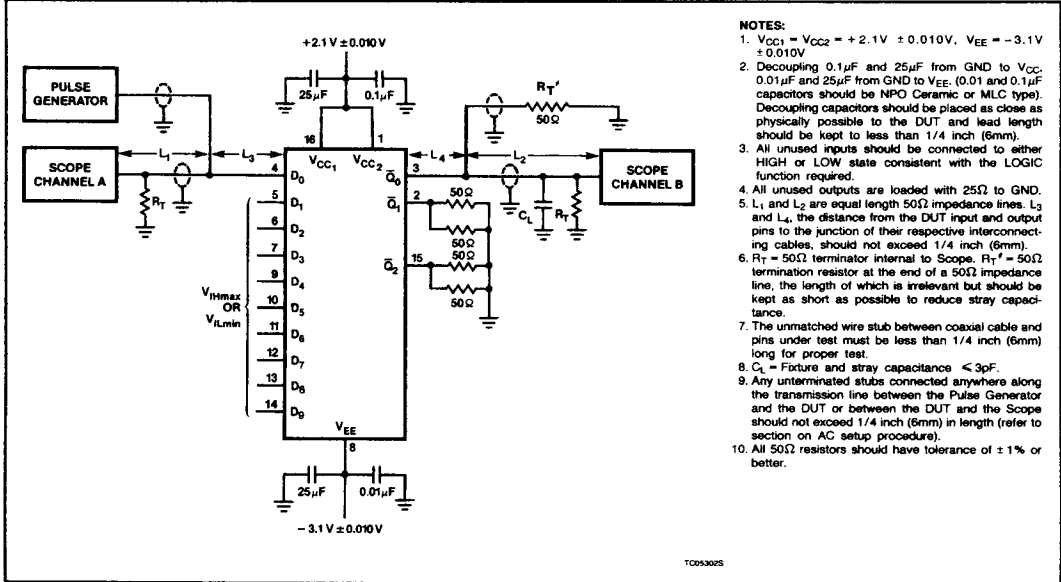

INPUT PULSE DEFINITION

