



New Release Specification

PRODUCT SPECIFICATION

General Description

The aTS20 is a precision CMOS temperature sensor that provides a cost-effective solution for space-constrained applications. The output voltage ramp of the aTS20 has a negative slope of $-11.77\text{mV}/^\circ\text{C}$. With a supply voltage of 2.4V to 6V, the aTS20 is accurate to $\pm 2^\circ\text{C}$ at 25°C , and to $\pm 3^\circ\text{C}$ over the range of -40°C to 125°C . Reducing the supply voltage to 2.4V does not change the negative and positive temperature extremes. As well, the aTS20 does not require external calibration. Calibration of each device is performed at the factory.

Features

- Extremely Low Power
- Precision Calibrated to $\pm 2^\circ\text{C}$ at 25°C
- Ultra Low Operating Current : $\leq 12\mu\text{A}$
- Temperature Range: -40°C to 125°C
- Linear Output Ramp: $-11.77\text{mV}/^\circ\text{C}$
- Output Ramp is Calibrated to Degrees Celsius
- Low Self Heating: 0.01°C typical in still air
- Uses a Single Positive Supply
- Operating Voltage Range: $+2.4\text{V}$ to $+6\text{V}$
- Non-linearity: $\leq 0.8^\circ\text{C}$

Applications

- Cellular Telephones
- Computers
- Battery Management
- FAX Machines/Printers/Copiers
- Portable Medical Instruments
- HVAC
- Power Supply Modules
- Disk Drives
- Appliances

Ordering Information

Part Number	Package	Temperature Range	Part Marking	How Supplied
aTS20F5	5-Pin SC-70	-40°C to $+125^\circ\text{C}$	Ayw	3000 units on T&R

y - year, w - week

Pin Configuration

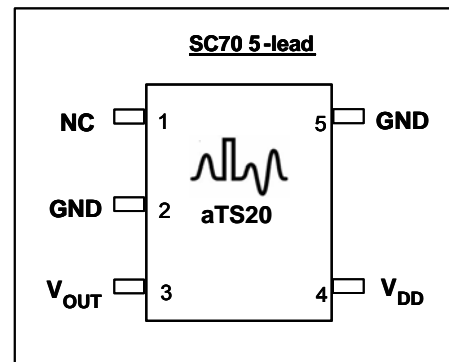

actual part marking below

Accuracy vs Temperature

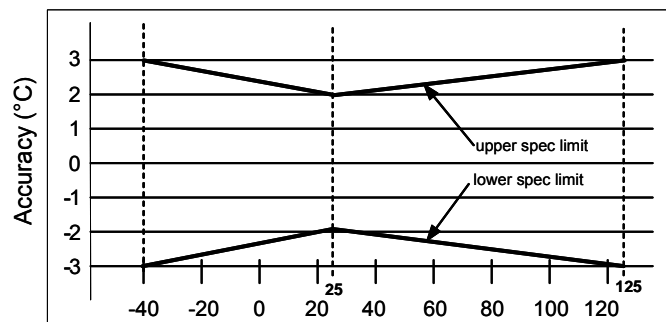

Absolute Maximum Ratings¹

Parameter		Rating
Supply Voltage		+7V
Output Voltage		$V_{DD} + 0.5V$
Continuous Current, any terminal		10mA
Storage Temperature Range		-60°C to +150°C
ESD ³	Human Body Model	2000V
	Machine Model	250V
Thermal Resistance - θ_{JA}		331°C/W
Lead Temp	Vapor Phase (60 sec)	260°C
	Infrared (15 sec)	220°C

Notes:

1. Absolute maximum ratings are limits beyond which operation may cause permanent damage to the device. These are stress ratings only; functional operation at or above these limits is not implied.
2. Human Body Model: 100pF capacitor discharged through a 1.5k Ω resistor into each pin. Machine Model: 200pF capacitor discharged directly into each pin.
3. These specifications are guaranteed only for the test conditions listed.

Recommended Operating Ratings

Symbol	Parameter	Min	Max	Units
V_{DD}	Supply Voltage	+2.4	+6	V
V_{OUT}	Output Voltage	0	V_{DD}	V
T_A	Operating Temperature Range	-40	+125	°C

Electrical Characteristics³

Limits apply for $-55^{\circ}C \leq T_A \leq +130^{\circ}C$ and $V_{DD} = +3.0V$ unless otherwise noted.

Parameter	Symbol	Conditions	Min	Typ	Max	Units
Accuracy ⁴		$T_A = +25^{\circ}C$	-2	± 1	+2	°C
		$T_A = -40^{\circ}C$ (T_{MIN})	-3	± 2	+3	°C
		$T_A = +125^{\circ}C$ (T_{MAX})	-3	± 2	+3	°C
Non-linearity ⁵				± 1		°C
Supply Current - Output floating	I_{DD}	$-40^{\circ}C \leq T_A \leq +125^{\circ}C$		9	12	μA
Output Sink Capability ^{6,7}	I_{OL}	$V_{DD} = +3V$		20		μA
Output Source Capability ^{6,7}	I_{OH}	$V_{DD} = +3V$		1		μA
Average Output Slope (Sensor Gain)	A_{OUT}			-11.77		mV/°C
Output Voltage	V_{OUT}	$T_A = 0^{\circ}C$		+1863.9		mV
Self Heating ⁸		SC-70-5		0.01043		°C

Notes:

4. Accuracy (expressed in °C) = Difference between calculated output voltage and measured output voltage. Calculated output voltage = -11.77mV/°C multiplied by device's case temperature at specified conditions of temperature, voltage and power supply plus an offset of 1863.9mV at 0°C.
5. Non-linearity is defined as the deviation of the output-voltage-versus-temperature curve from the best-fit straight line, over the device's rated temperature range.
6. Lowest output current should be targeted; higher currents result in more self-heating of the device.
7. Higher capacitive loads may be driven by the output in a static mode, but it may require a delay time before initial read at power up to allow charging of the capacitor.
8. Max Self Heating = $\theta_{JA} \times (V_{DD} \times I_{DD})$. Assumes a capacitive load.

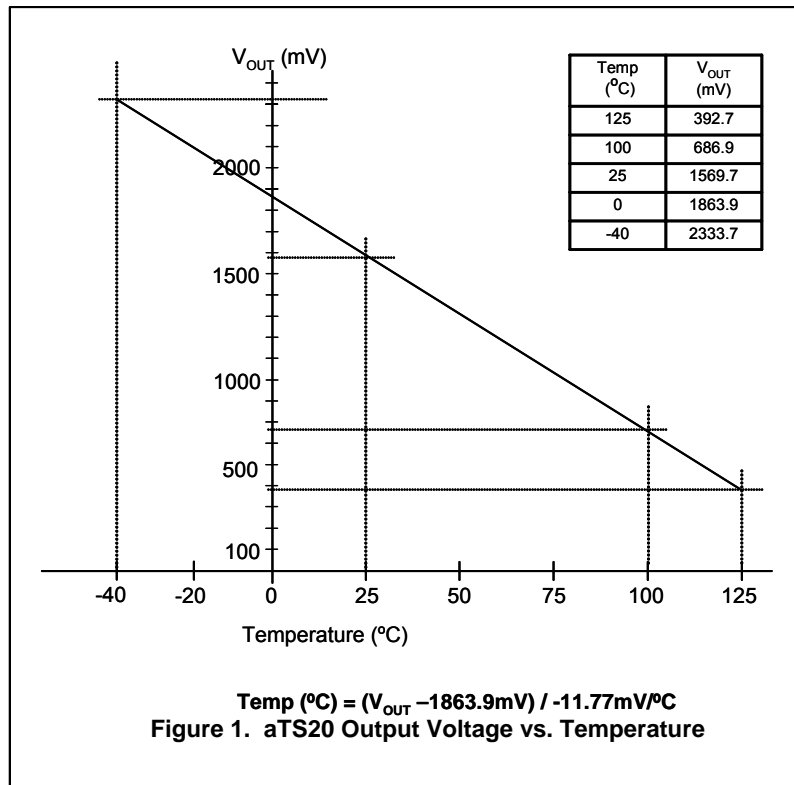

Mounting

The aTS20 can be easily mounted by gluing or cementing it to a surface. In this case, its temperature will be within about 0.01°C of the temperature of the surface it is attached to if the ambient air temperature is almost the same as the surface temperature. If the air temperature is much higher or lower than the surface temperature, the actual temperature of the aTS20 die will be at an intermediate temperature between the surface temperature and the air temperature.

To ensure good thermal conductivity, the backside of the aTS20 die is directly attached to the GND pin. The lands and traces to the aTS20 will, of course, be part of the printed circuit board, which is the object whose temperature is being measured. These printed circuit

board lands and traces will not cause the aTS20's temperature to deviate from the desired temperature.

Alternatively, the aTS20 can be mounted inside a sealed-end metal tube, and can then be dipped into a bath or screwed into a threaded hole in a tank. As with any IC, the aTS20 and accompanying wiring and circuits must be kept insulated and dry to avoid leakage and corrosion. This is especially true if the circuit may operate at cold temperatures where condensation can occur. Printed-circuit coatings and varnishes such as Humiseal and epoxy paint or dips can be used to ensure that moisture cannot corrode the aTS20 or its connections.

Performance Characteristics

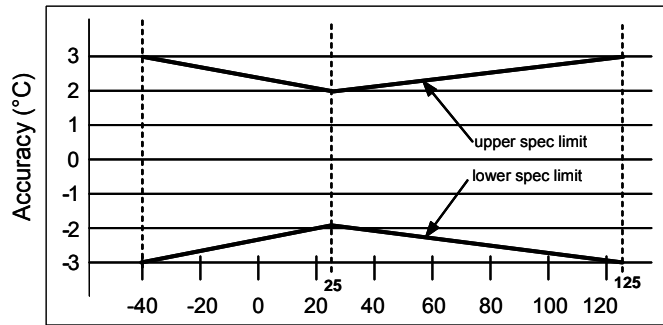

Figure 2. aTS20 Accuracy Range vs Temperature

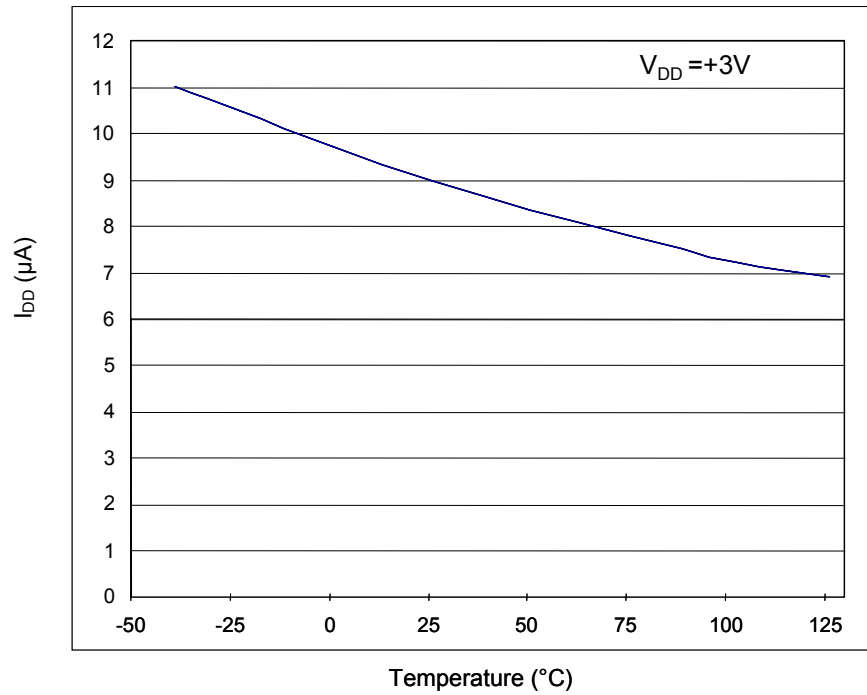
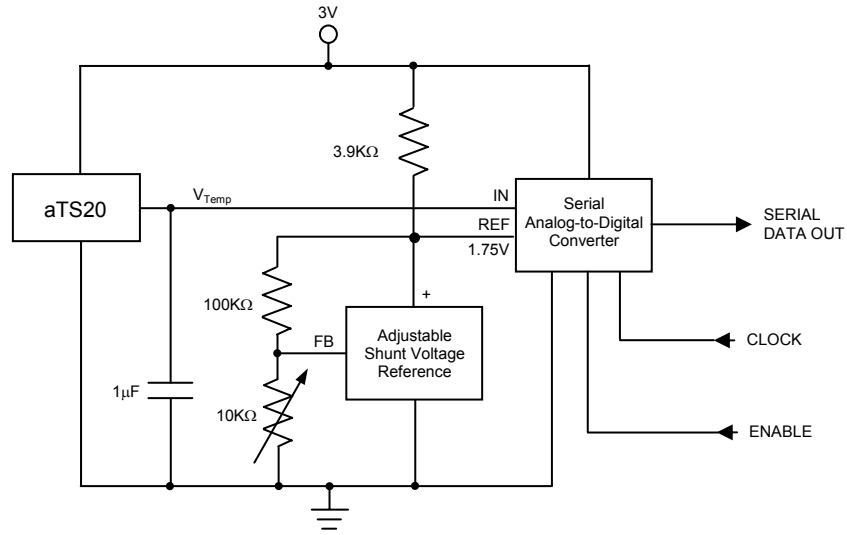

Figure 3. aTS Current vs Temperature

Typical Applications



Note: The full scale of the A-to-D Converter will typically be limited to +125°C simply by the number of bits available in the conversion. The aTS20 would still be capable of its full output swing.

Figure 4. Serial Output Temperature to Digital Converter

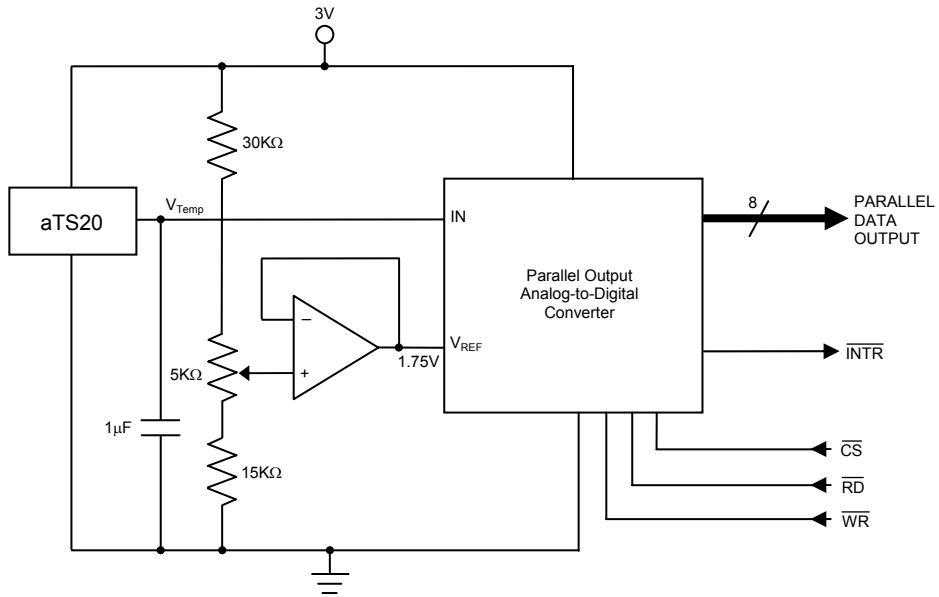
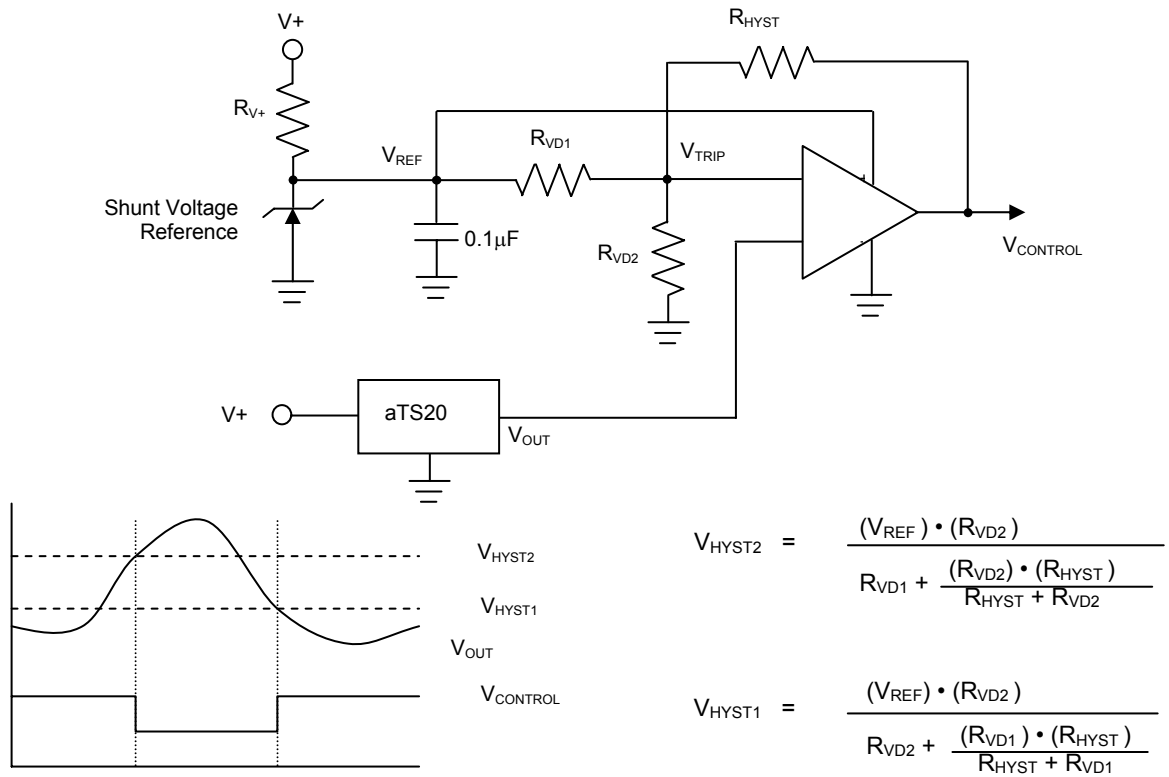
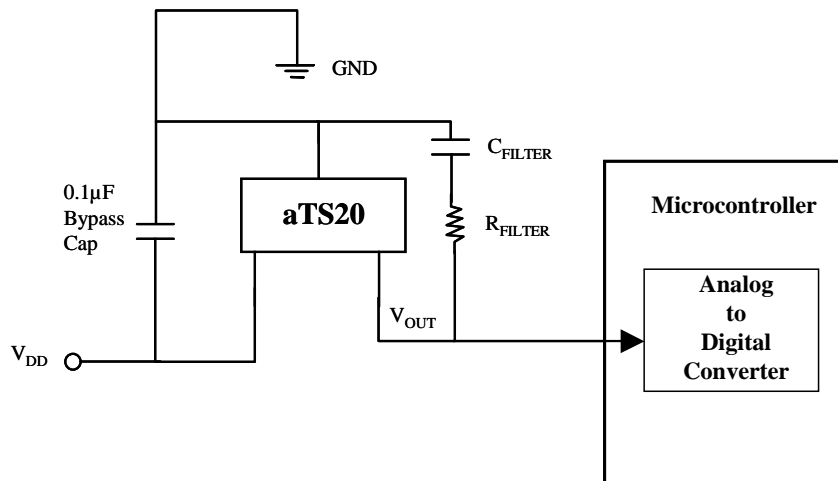

Figure 5. Parallel Output Temperature to Digital Converter (Full Scale = +125°C)

Typical Applications (cont'd)

Note: V_{REF} is set by the Shunt Voltage Reference. For $V_{CONTROL}$ high is an alarm state or control for activating cooling/fan.

Figure 6. Thermostat/Fan Controller

Figure 7. Digital Temperature output through a microcontroller

Loading

The aTS20 will handle sizable capacitive loads up to 300pF without any special considerations. In an extremely noisy environment it may be advisable to add some filtering to minimize noise in the output voltage. It is also recommended that a 0.1 μ F bypass capacitor be added between the supply voltage and ground. This is due to the instant current demand caused by switching CMOS transistors. Normally it is unadvisable to put a sufficiently large supply (particularly in portable electronics) to be able to handle the dynamic currents of CMOS transistors. It is a much simpler solution to use a bypass capacitor to sustain the supply voltage during this short demand period.

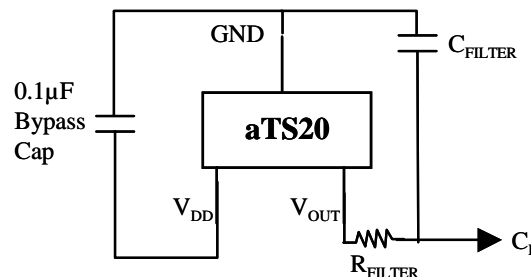
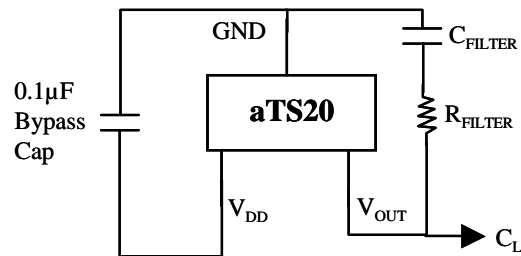
In environments that are particularly noisy it may be necessary to add a low-pass filter network to the output of the device. As shown in Figure 8, a 1 μ F capacitor in addition to the output impedance of the device and a 200 Ω series resistor for a low-pass filter that will pass the slow thermal time constant of the aTS20, while filtering the higher frequency noise. The response time of the aTS20 can be affected by this filter network, therefore values for $C_{\text{FILTER}} < 1500\text{pF}$ are recommended.



Resistor / Capacitor Combinations for Figure 8 Filter Network	
R _{FILTER}	C _{FILTER}
200 Ω	1 μ F
470 Ω	0.1 μ F
680 Ω	0.01 μ F
1000 Ω	1000 pF
10k Ω	100pF
100k Ω	10pF

Figure 8. aTS20 with Filter Network for Noisy Environments or for Capacitive Loads Greater than 300pF

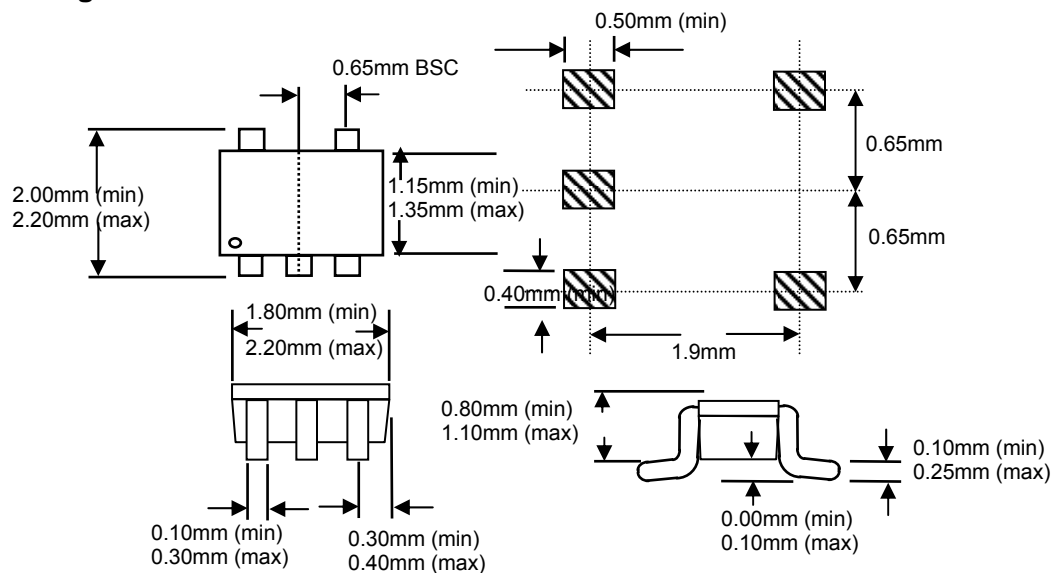
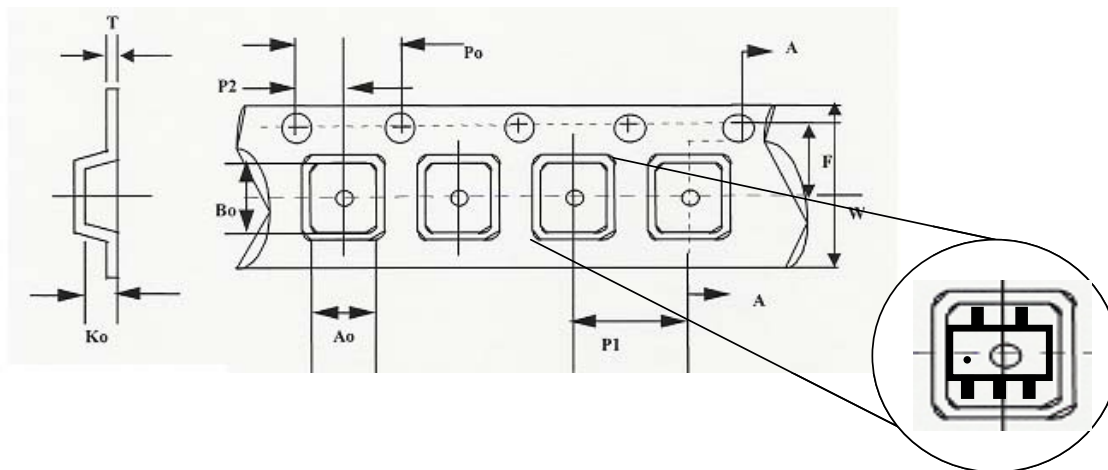
SC-70-5 Package Dimensions

Tape and Reel Data

W	8.1 ± 0.20 mm
A₀	2.25 ± 0.10 mm
B₀	2.70 ± 0.10 mm
K₀	1.20 ± 0.10 mm
P₀	4.00 ± 0.10 mm
P₁	4.00 ± 0.10 mm
P₂	2.00 ± 0.05 mm
T	0.30 ± 0.05 mm
F	3.50 ± 0.05 mm

Andigilog, Inc.
 8380 S. Kyrene Rd., Suite 101
 Tempe, Arizona 85284-2120
 Tel: (480) 940-6200
 Fax: (480) 940-4255

Data Sheet Classifications**Preliminary Specification**

This classification is shown on the heading of each page of a specification for products that are either under development (design and qualification), or in the formative planning stages. Andigilog reserves the right to change or discontinue these products without notice.

New Release Specification

This classification is shown on the heading of the first page only of a specification for products that are either under the later stages of development (characterization and qualification), or in the early weeks of release to production. Andigilog reserves the right to change the specification and information for these products without notice.

Fully Released Specification

Fully released datasheets do not contain any classification in the first page header. These documents contain specification on products that are in full production. Andigilog will not change any guaranteed limits without written notice to the customers. Obsolete datasheets that were written prior to January 1, 2001 without any header classification information should be considered as obsolete and non-active specifications, or in the best case as Preliminary Specifications.

Notes: