



MX28F160C3T/B

16M-BIT [1M x16] CMOS SINGLE VOLTAGE 3V ONLY FLASH MEMORY

FEATURES

- Bit Organization: 1,048,576 x 16
- Single power supply operation
 - VCC=VCCQ=2.7~3.6V for read, erase and program operation
 - VPP=12V for fast production programming
 - Operating temperature:-40° C~85° C
- Fast access time : 70/90/110ns
- Low power consumption
 - 9mA typical active read current, f=5MHz
 - 18mA typical program current (VPP=1.65~3.6V)
 - 21mA typical erase current (VPP=1.65~3.6V)
 - 7uA typical standby current under power saving mode
- Sector architecture
 - Sector structure : 4Kword x 2 (boot sectors), 4Kword x 6 (parameter sectors), 32Kword x 31 (main sectors)
 - Top/Bottom Boot
- Auto Erase and Auto Program
 - Automatically program and verify data at specified address
 - Auto sector erase at specified sector
- Automatic Suspend Enhance
 - Word write suspend to read
 - Sector erase suspend to word write
 - Sector erase suspend to read register report
- Automatic sector erase, word write and sector lock/unlock configuration
- Status Reply
 - Detection of program and erase operation completion.
 - Command User Interface (CUI)
 - Status Register (SR)
- Data Protection Performance
 - Include boot sectors and parameter and main sectors to be locked/unlocked
- 100,000 minimum erase/program cycles
- Common Flash Interface (CFI)
- 128-bit Protection Register
 - 64-bit Unique Device Identifier
 - 64-bit User-Programmable
- Latch-up protected to 100mA from -1V to VCC+1V
- Package type:
 - 48-pin TSOP (12mm x 20mm)
 - 48-ball CSP (8mm x 6mm)

GENERAL DESCRIPTION

The MX28F160C3T/B is a 16-mega bit Flash memory organized as 1M words of 16 bits. The 1M word of data is arranged in eight 4Kword boot and parameter sectors, and thirty-one 32K word main sectors which are individually erasable. MXIC's Flash memories offer the most cost-effective and reliable read/write non-volatile random access memory. The MX28F160C3T/B is packaged in 48-pin TSOP and 48-ball CSP. It is designed to be re-programmed and erased in system or in standard EPROM programmers.

The standard MX28F160C3T/B offers access time as

fast as 70ns, allowing operation of high-speed microprocessors without wait states.

MXIC's Flash memories augment EPROM functionality with in-circuit electrical erasure and programming. The MX28F160C3T/B uses a command register to manage this functionality. The command register allows for 100% TTL level control inputs and fixed power supply levels during erase and programming, while maintaining maximum EPROM compatibility.

MXIC Flash technology reliably stores memory contents even after 100,000 erase and program cycles. The MXIC cell is designed to optimize the erase and programming



mechanisms. In addition, the combination of advanced tunnel oxide processing and low internal electric fields for erase and program operations produces reliable cycling. The MX28F160C3T/B uses a 2.7V~3.6V VCC supply to perform the High Reliability Erase and auto Program/Erase algorithms.

The highest degree of latch-up protection is achieved with MXIC's proprietary non-epi process. Latch-up protection is proved for stresses up to 100 milliamps on address and data pin from -1V to VCC + 1V.

The dedicated VPP pin gives complete data protection when $VPP < VPPLK$.

A Command User Interface (CUI) serves as the interface between the system processor and internal operation of the device. A valid command sequence written to the CUI initiates device automation. An internal Write State Machine (WSM) automatically executes the algorithms and timings necessary for erase, word write and sector lock/unlock configuration operations.

A sector erase operation erases one of the device's 32K-word sectors typically within 1.0s, 4K-word sectors typically within 0.5s independent of other sectors. Each sector can be independently erased minimum 100,000 times. Sector erase suspend mode allows system software to suspend sector erase to read or write data from any other sector.

Writing memory data is performed in word increments of the device's 32K-word sectors typically within 0.8s and 4K-word sectors typically within 0.1s. Word program suspend mode enables the system to read data or execute code from any other memory array location.

MX28F160C3T/B features with individual sectors locking by using a combination of bits thirty-nine sector lock-bits and WP, to lock and unlock sectors.

The status register indicates when the WSM's sector erase, word program or lock configuration operation is done.

The access time is 70/90/110ns (tELQV) over the operating temperature range (-40°C to +85°C) and VCC supply voltage range of 2.7V~3.6V.

MX28F160C3T/B's power saving mode feature substan-

tially reduces active current when the device is in static mode (addresses not switching). In this mode, the typical ICCS current is 7uA (CMOS) at 3.0V VCC.

As \overline{CE} and \overline{RP} are at VCC, ICC CMOS standby mode is enabled. When \overline{RP} is at GND, the reset mode is enabled which minimize power consumption and provide data write protection.

A reset time (tPHQV) is required from \overline{RP} switching high until outputs are valid. Similarly, the device has a wake time (tPHEL) from \overline{RP} -high until writes to the CUI are recognized. With RP at GND, the WSM is reset and the status register is cleared.

BLOCK DIAGRAM

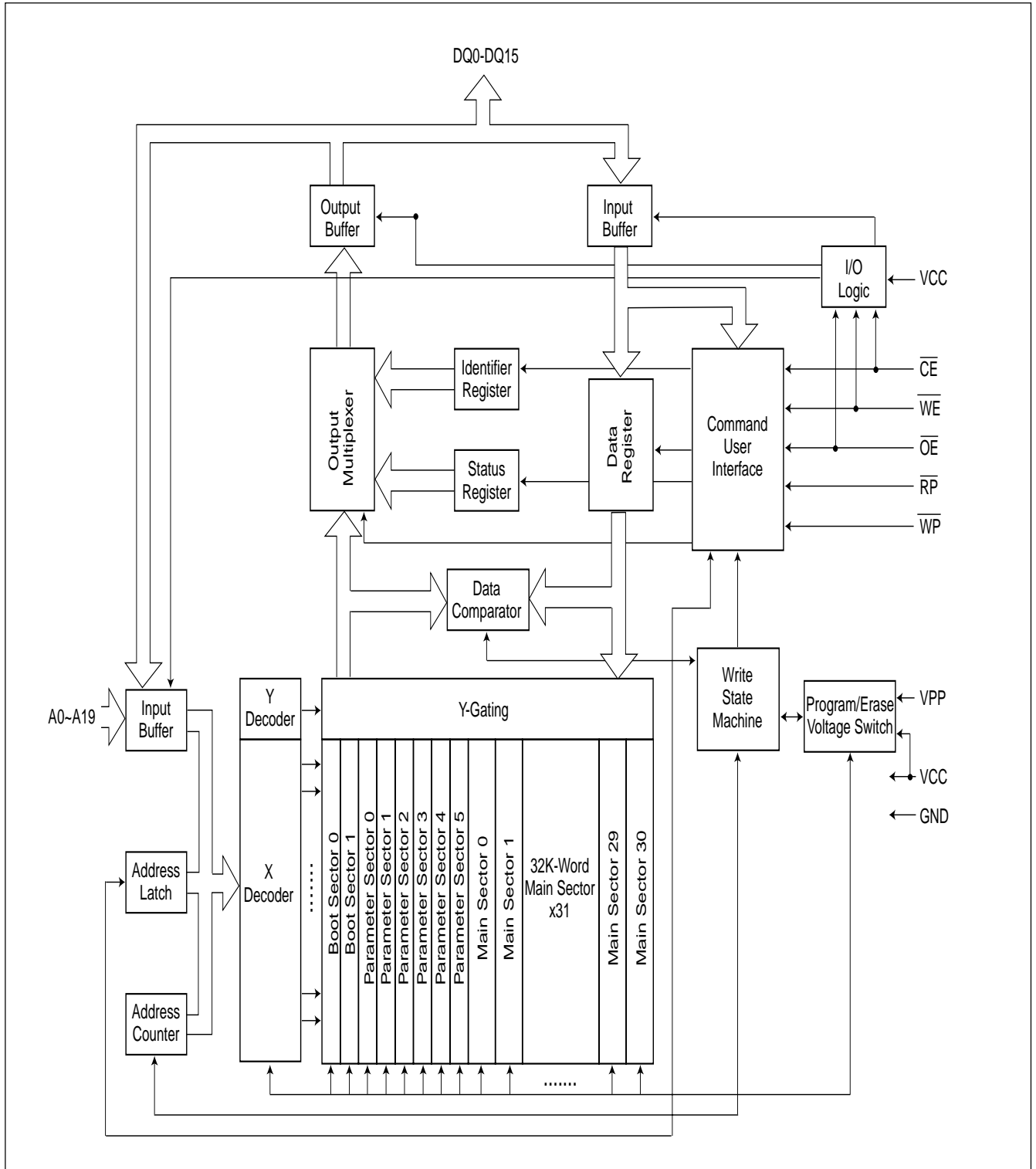

PIN CONFIGURATIONS

48 TSOP (Standard Type) (12mm x 20mm)



48 Ball CSP (8mm x 6mm) Top View, Ball Down for MX28F160C3T/BXA (Ball Pitch=0.75mm, Ball Width=0.35mm)

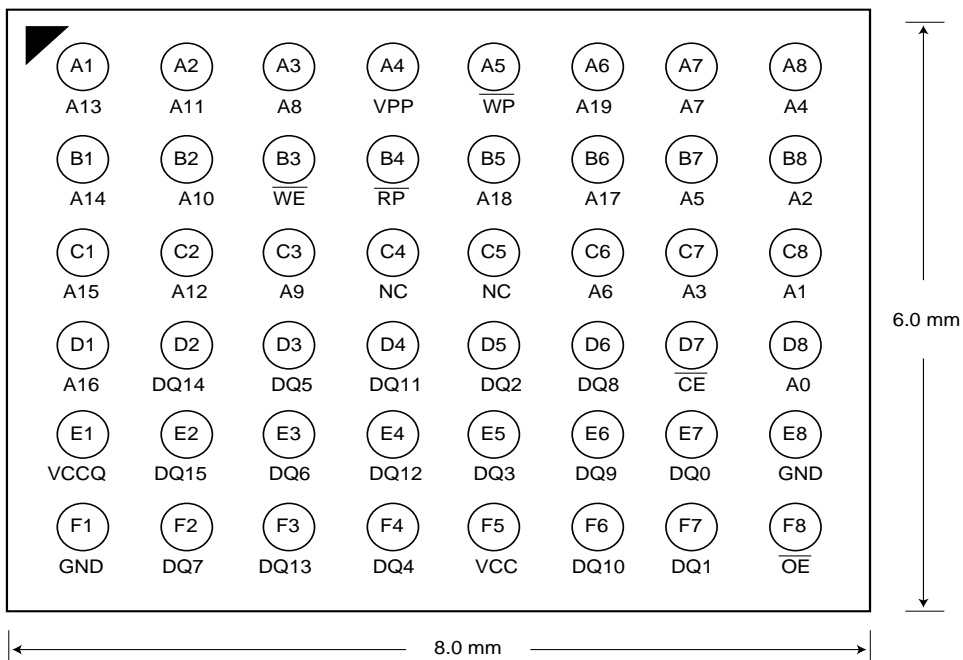

Table 1. Pin Description

Symbol	Type	Description and Function
A0-A19	input	Address inputs for memory address. Data pin float to high-impedance when the chip is deselected or outputs are disable. Addresses are internally latched during a write or erase cycle.
DQ0-DQ15	input/output	Data inputs/outputs: Inputs array data on the second \overline{CE} and \overline{WE} cycle during a program command. Data is internally latched. Outputs array and configuration data. The data pin float to tri-state when the chip is de-selected.
\overline{CE}	input	Chip Enable : Activates the device's control logic, input buffers, and sense amplifiers. \overline{CE} high de-selects the memory device and reduce power consumption to standby level. \overline{CE} is active low.
\overline{RP}	input	Reset/Deep Power Down: when $\overline{RP}=VIL$, the device is in reset/deep power down mode, which drives the outputs to High Z, resets the WSM and minimizes current level. When $\overline{RP}=VIH$, the device is normal operation. When \overline{RP} transitions from VIL to VIH, the device defaults to the read array mode.
\overline{WE}	input	Write Enable: to control write to CUI and array sector. $\overline{WE}=VIL$ becomes active. The data and addresses are latched on the rising edge of the second \overline{WE} pulse.
VPP	input/supply	Program/Erase Power Supply:(1.65V~3.6V or 11.4V~12.6V) Lower $VPP \leq VPPLK$, to protect any contents against Program and Erase Command. Set $VPP=VCC$ for in-system Read, Program and Erase Operation. Raise VPP to 12V \pm 5% for faster program and erase in a production environment.
\overline{OE}	input	Output enable: gates the device's outputs during a read cycle.
WP	input	Write Protect: When \overline{WP} is VIL, the sectors marked Lock Down can't be unlocked through software. When \overline{WP} is VIH, the lock down mechanism is disable and sectors previously locked down are now locked and can be unlocked and locked through software. After \overline{WP} goes low, any sectors previously marked lock down revert to that state.
VCC	supply	Device power supply: (2.7V~3.6V).
VCCQ	input	I/O Power Supply: supplies for input/output buffers. (VCCQ must be tied to VCC)
GND	supply	Ground voltage: all the GND pin shall not be connected.



SECTOR STRUCTURE (TOP)

Sector	Sector Size	Address Range (h)
Boot Sector 0	4K Word	FF000 ~ FFFFF
Boot Sector 1	4K Word	FE000 ~ FEFFF
Parameter Sector 0	4K Word	FD000 ~ FDFFF
Parameter Sector 1	4K Word	FC000 ~ FCFFF
Parameter Sector 2	4K Word	FB000 ~ FBFFF
Parameter Sector 3	4K Word	FA000 ~ FAFFF
Parameter Sector 4	4K Word	F9000 ~ F9FFF
Parameter Sector 5	4K Word	F8000 ~ F8FFF
Main Sector 0	32K Word	F0000 ~ F7FFF
Main Sector 1	32K Word	E8000 ~ EFFFF
Main Sector 2	32K Word	E0000 ~ E7FFF
Main Sector 3	32K Word	D8000 ~ DFFFF
Main Sector 4	32K Word	D0000 ~ D7FFF
Main Sector 5	32K Word	C8000 ~ CFFFF
Main Sector 6	32K Word	C0000 ~ C7FFF
Main Sector 7	32K Word	B8000 ~ BFFFF
Main Sector 8	32K Word	B0000 ~ B7FFF
Main Sector 9	32K Word	A8000 ~ AFFFF
Main Sector 10	32K Word	A0000 ~ A7FFF
Main Sector 11	32K Word	98000 ~ 9FFFF
Main Sector 12	32K Word	90000 ~ 97FFF
Main Sector 13	32K Word	88000 ~ 8FFFF
Main Sector 14	32K Word	80000 ~ 87FFF
Main Sector 15	32K Word	78000 ~ 7FFFF
Main Sector 16	32K Word	70000 ~ 77FFF
Main Sector 17	32K Word	68000 ~ 6FFFF
Main Sector 18	32K Word	60000 ~ 67FFF
Main Sector 19	32K Word	58000 ~ 5FFFF
Main Sector 20	32K Word	50000 ~ 57FFF
Main Sector 21	32K Word	48000 ~ 4FFFF
Main Sector 22	32K Word	40000 ~ 47FFF
Main Sector 23	32K Word	38000 ~ 3FFFF
Main Sector 24	32K Word	30000 ~ 37FFF
Main Sector 25	32K Word	28000 ~ 2FFFF
Main Sector 26	32K Word	20000 ~ 27FFF
Main Sector 27	32K Word	18000 ~ 1FFFF
Main Sector 28	32K Word	10000 ~ 17FFF
Main Sector 29	32K Word	08000 ~ 0FFFF
Main Sector 30	32K Word	00000 ~ 07FFF



SECTOR STRUCTURE (BOTTOM)

Sector	Sector Size	Address Range (h)
Boot Sector 0	4K Word	00000 ~ 00FFF
Boot Sector 1	4K Word	01000 ~ 01FFF
Parameter Sector 0	4K Word	02000 ~ 02FFF
Parameter Sector 1	4K Word	03000 ~ 03FFF
Parameter Sector 2	4K Word	04000 ~ 04FFF
Parameter Sector 3	4K Word	05000 ~ 05FFF
Parameter Sector 4	4K Word	06000 ~ 06FFF
Parameter Sector 5	4K Word	07000 ~ 07FFF
Main Sector 0	32K Word	08000 ~ 0FFFF
Main Sector 1	32K Word	10000 ~ 17FFF
Main Sector 2	32K Word	18000 ~ 1FFFF
Main Sector 3	32K Word	20000 ~ 27FFF
Main Sector 4	32K Word	28000 ~ 2FFFF
Main Sector 5	32K Word	30000 ~ 37FFF
Main Sector 6	32K Word	38000 ~ 3FFFF
Main Sector 7	32K Word	40000 ~ 47FFF
Main Sector 8	32K Word	48000 ~ 4FFFF
Main Sector 9	32K Word	50000 ~ 57FFF
Main Sector 10	32K Word	58000 ~ 5FFFF
Main Sector 11	32K Word	60000 ~ 67FFF
Main Sector 12	32K Word	68000 ~ 6FFFF
Main Sector 13	32K Word	70000 ~ 77FFF
Main Sector 14	32K Word	78000 ~ 7FFFF
Main Sector 15	32K Word	80000 ~ 87FFF
Main Sector 16	32K Word	88000 ~ 8FFFF
Main Sector 17	32K Word	90000 ~ 97FFF
Main Sector 18	32K Word	98000 ~ 9FFFF
Main Sector 19	32K Word	A0000 ~ A7FFF
Main Sector 20	32K Word	A8000 ~ AFFFF
Main Sector 21	32K Word	B0000 ~ B7FFF
Main Sector 22	32K Word	B8000 ~ BFFFF
Main Sector 23	32K Word	C0000 ~ C7FFF
Main Sector 24	32K Word	C8000 ~ CFFFF
Main Sector 25	32K Word	D0000 ~ D7FFF
Main Sector 26	32K Word	D8000 ~ DFFFF
Main Sector 27	32K Word	E0000 ~ E7FFF
Main Sector 28	32K Word	E8000 ~ EFFFF
Main Sector 29	32K Word	F0000 ~ F7FFF
Main Sector 30	32K Word	F8000 ~ FFFFF

2 PRINCIPLES OF OPERATION

The product includes an on-chip WSM to manage sector erase, word write and lock-bit configuration functions.

After initial device power-up or return from reset mode (see section on Bus Operations), the device defaults to read array mode. Manipulation of external memory control pins allow array read, standby and output disable operations.

Status register and identifier codes can be accessed through the CUI independent of the VPP voltage. All functions associated with altering memory contents - sector erase, word write, sector lock/unlock, status and identifier codes - are accessed via the CUI and verified through the status register.

Commands are written using standard microprocessor write timings. The CUI contents serve as input to the WSM, which controls the sector erase, word write and sector lock/unlock. The internal algorithms are regulated by the WSM, including pulse repetition, internal verification and margining of data. Addresses and data are internally latched during write cycles. Address is latched at falling edge of \overline{CE} and data latched at rising edge of \overline{WE} . Writing the appropriate command outputs array data, accesses the identifier codes or outputs status register data.

Interface software that initiates and polls progress of sector erase, word write and sector lock/unlock can be stored in any sector. This code is copied to and executed from system RAM during flash memory updates. After successful completion, reads are again possible via the Read Array command. Sector erase suspend allows system software to suspend a sector erase to read/write data from/to sectors other than that which is suspend. Word write suspend allows system software to suspend a word write to read data from any other flash memory array location.

With the mechanism of sector lock, memory contents cannot be altered due to noise or unwanted operation. When $\overline{RP} = V_{IH}$ and $V_{CC} < V_{LKO}$ (lockout voltage), any data write alteration can be failure. During read operation, if write VPP voltage is below V_{PPLK} , then hardware level data protection is achieved. With CUI's two-step command sequence sector erase, word write or sector lock/unlock, software level data protection is achieved also.

3 BUS OPERATION

The local CPU reads and writes flash memory in-system. All bus cycles to or from the flash memory conform to standard microprocessor bus cycles.

3.1 Read

Information can be read from any sector, configuration codes or status register independent of the VPP voltage. \overline{RP} can be at V_{IH} .

The first task is to write the appropriate read mode command (Read Array, Read Configuration, Read Query or Read Status Register) to the CUI. Upon initial device power-up or after exit from reset, the device automatically resets to read array mode. In order to read data, control pins set for \overline{CE} , \overline{OE} , \overline{WE} , \overline{RP} and \overline{WP} must be driven to active. \overline{CE} and \overline{OE} must be active to obtain data at the outputs. \overline{CE} is the device selection control. \overline{OE} is the data output (DQ0-DQ15) control and active drives the selected memory data onto the I/O bus, \overline{WE} must be V_{IH} , \overline{RP} must be V_{IH} , \overline{WP} must be at V_{IL} or V_{IH} .

3.2 Output Disable

With \overline{OE} at a logic-high level (V_{IH}), the device outputs are disabled. Output pins (DQ0-DQ15) are placed in a high-impedance state.

3.3 Standby

\overline{CE} at a logic-high level (V_{IH}) places the device in standby mode which substantially reduces device power consumption. DQ0~DQ15 outputs are placed in a high-impedance state independent of \overline{OE} . If deselected during sector erase, word write or sector lock/unlock, the device continues functioning, and consuming active power until the operation completes.

3.4 Reset

As $\overline{RP} = V_{IL}$, it initiates the reset mode. The device enters reset/deep power down mode. However, the data stored in the memory has to be sustained at least 100ns in the read mode before the device becomes deselected

and output high impedance state.

In read modes, \overline{RP} -low deselects the memory, places output drivers in a high-impedance state and turns off all internal circuits. RP must be held low for a minimum of 100ns. Time tPHQV is required after return from reset mode until initial memory access outputs are valid. After this wake-up interval tPHEL or tPHWL, normal operation is restored. The CUI is reset to read array mode and status register is set to 80H. Sector lock bit is set at lock status.

During sector erase, word write or sector lock/unlock modes, RP-low will abort the operation. Memory contents being altered are no longer valid; the data may be partially erased or written.

In addition, CUI will go into either array read mode or erase/write interrupted mode. When power is up and the device reset subsequently, it is necessary to read status register in order to assure the status of the device. Recognizing status register (SR.7~0) will assure if the device goes back to normal reset and enters array read mode.

3.5 Read Configuration Codes

The read configuration codes operation outputs the manufacturer code, device code, sector lock configuration codes, and the protection register. Using the manufacturer and device codes, the system CPU can automatically match the device with its proper algorithms. The sector lock codes identify locked and unlocked sectors.

3.6 Write

Writing commands to the CUI enable reading of device data and identifier codes. They also control inspection and clearing of the status register. When VCC=2.7V-3.6V and VPP within VPP1 or VPP2 range, the CUI additionally controls sector erase, word write and sector lock/unlock.

The Sector Erase command requires appropriate command data and an address within the sector to be erased. The Full Chip Erase command requires appropriate command data and an address within the device. The Word Write command requires the command and address of the location to be written. Set Sector lock/unlock com-

mands require the command and address within the device or sector within the device (Sector Lock) to be locked. The Clear Sector Lock-Bits command requires the command and address within the device.

The CUI does not occupy an addressable memory location. It is written when \overline{WE} and \overline{CE} are active (whichever goes high first). The address and data needed to execute a command are latched on the rising edge of \overline{WE} or \overline{CE} . Standard microprocessor write timings are used.

4 COMMAND DEFINITIONS

The flash memory has four read modes: read array, read configuration, read status, read query, and two write modes: program, erase. These read modes are accessible independent of the VPP voltage. But write modes are disabled during $VPP < VPPLK$. Placing VPP on VPP1/2 enables successful sector erase, word write and sector lock/unlock.

Device operations are selected by writing specific commands into the CUI. Table 3 defines these commands.

Table 2. Bus Operation

Mode	Notes	\overline{RP}	\overline{CE}	\overline{OE}	\overline{WE}	DQ0~DQ15
Read	1,2	VIH	VIL	VIL	VIH	DOUT
Output Disable	2	VIH	VIL	VIH	VIH	High Z
Standby	2	VIH	VIH	X	X	High Z
Reset	2	VIL	X	X	X	High Z
Write	2,3,4,5	VIH	VIL	VIH	VIL	DIN

Notes:

1. Refer to DC Characteristics for VPPLK, VPP1, VPP2 voltage.
2. X can be VIL or VIH for pin and addresses.
3. RP at $GND \pm 0.2$ to ensure the lowest power consumption.
4. Refer to Table 3 for valid DIN during a write operation.
5. To program or erase the lockable sectors holds \overline{WP} at VIH.



Table 3. Command Definition (1)

Command	Bus Cycles Required	Notes	First Bus Cycle			Second Bus Cycle		
			Operation (1)	Address (2)	Data (3)	Operation (1)	Address (2)	Data (3)
Read Array	1		Write	X	FFH			
Read Configuration	≥ 2	2,4	Write	X	90H	Read	IA	ID
Read Query	2	2,7	Write	X	98H	Read	QA	QD
Read Status Register	2	3	Write	X	70H	Read	X	SRD
Clear Status Register	1	3	Write	X	50H			
Sector Erase/Confirm	2		Write	X	20H	Write	SA	D0H
Word Write	2	2,5	Write	X	40H/10H	Write	WA	WD
Program/Erase Suspend	1		Write	X	B0H			
Program/Erase Resume	1		Write	X	D0H			
Sector Lock	2		Write	X	60H	Write	SA	01H
Sector Unlock	2	6	Write	X	60H	Write	SA	D0H
Lock-Down Sector	2		Write	X	60H	Write	SA	2FH
Protection Program	2		Write	X	C0H	Write	PA	PD

Notes:

1. Bus operation are defined in Table 2 and referred to AC Timing Waveform.
2. X=Any address within device.
 IA=ID-Code Address (refer to Table 4).
 ID=Data read from identifier code.
 SA=Sector Address within the sector being erased.
 WA=Address of memory location to be written.
 WD=Data to be written at location WA.
 PA=Program Address, PD=Program Data
 QA=Query Address, QD=Query Data.
3. Data is latched from the rising edge of WE or CE (whichever goes high first)
 SRD=Data read from status register, see Table 6 for description of the status register bits.
4. Following the Read Configuration codes command, read operation access manufacturer, device codes, sector lock/unlock codes, see chapter 4.2.
5. Either 40H or 10H command is recognized by the WSM as word write setup.
6. The sector unlock operation simultaneously clear all sector lock.
7. Read Query Command is read for CFI query information.

4.1 Read Array Command

Upon initial device power-up and after exit from reset mode, the device defaults to read array mode. This operation is also initiated by writing the Read Array command. The device remains enabled for reads until another command is written. Once the internal WSM has started a sector erase, word write or sector lock configuration the device will not recognize the Read Array command until the WSM completes its operation unless the WSM is suspended via a Sector Erase Suspend or Word Write Suspend command. If \overline{RP} =VIL device is in read Read Array command mode, this read operation no longer requires VPP. The Read Array command functions independently of the VPP voltage and \overline{RP} can be VIH.

4.2 Read Configuration Codes Command

The configuration code operation is initiated by writing the Read Configuration Codes command (90H). To return to read array mode, write the Read Array Command (FFH). Following the command write, read cycles from addresses shown in Table 4 retrieve the manufacturer, device, sector lock configuration codes and the protection register(see Table 4 for configuration code values). To terminate the operation, write another valid command. Like the Read Array command, the Read Configuration Codes command functions independently of the VPP voltage and \overline{RP} can be VIH. Following the Read Configuration Codes command, the information is shown:

Table 4: ID Code

Code	Address (A19-A0)	Data (DQ15-DQ0)
Manufacturer Code	00000H	00C2H
Device Code(Top/Bottom)	00001H	88C2/88C3H
Sector Lock Configuration	XX002H	Lock
- Sector is unlocked		DQ0=0
- Sector is locked		DQ0=1
- Sector is locked-down		DQ1=1
Protection Register Lock	80	PR-LK
Protection Register	81-88	PR

4.3 Read Status Register Command

CUI writes read status command (70H). The status register may be read to determine when a sector erase, word write or lock-bit configuration is complete and whether the operation completed successfully. (refer to table 6) It may be read at any time by writing the Read Status Register command. After writing this command, all subsequent read operations output data from the status register until another valid command is written. The status register contents are latched on the falling edge of \overline{CE} or \overline{OE} , whichever occurs last. \overline{CE} or \overline{OE} must toggle to VIH before further reads to update the status register latch. The Read Status Register command functions independently of the VPP voltage. \overline{RP} can be VIH.

4.4 Clear Status Register Command

Status register bits SR.5, SR.4, SR.3 or SR.1 are set to "1"s by the WSM and can only be reset by the Clear Status Register command (50H). These bits indicate various failure conditions (see Table 6). By allowing system software to reset these bits, several operations (such as cumulatively erasing multiple sectors or writing several words in sequence) may be performed. The status register may be polled to determine if an error occurred during the sequence.

To clear the status register, the Clear Status Register command (50H) is written on CUI. It functions independently of the applied VPP Voltage. \overline{RP} can be VIH. This command is not functional during sector erase or word write suspend modes.

4.5 Sector Erase Command

Erase is executed one sector at a time and initiated by a two-cycle command. A sector erase setup is first written (20H), followed by a sector erase confirm (D0H). This command sequence requires appropriate sequencing and an address within the sector to be erased. Sector pre-conditioning, erase, and verify are handled internally by the WSM. After the two-cycle sector erase sequence is written, the device automatically outputs status register data when read (see Figure 8). The CPU can detect sector erase completion by analyzing the output data of the status register bit SR.7.

When the sector erase is complete, status register bit SR.5 should be checked. If a sector erase error is detected, the status register should be cleared before system software attempts corrective actions. The CUI remains in read status register mode until a new command is issued.

This two-step command sequence of set-up followed by execution ensures that sector contents are not accidentally erased. An invalid sector Erase command sequence will result in both status register bits SR.4 and SR.5 being set to "1". Also, reliable sector erasure can only occur when 2.7V~3.6V and $VPP=VPP1/2$. In the absence of this high voltage, sector contents are protected against erasure. If sector erase is attempted while $VPP \leq VPPLK$ SR.3 and SR.5 will be set to "1". To successfully erase the boot sector, the corresponding sector lock-bit must be clear first. In parameter and sectors case, it must be cleared the corresponding sector lock-bit. If sector erase is attempted when the excepting above sector being locked conditions, SR.1 and SR.5 will be set to "1". Sector erase is not functional.

4.6 Word Write Command

Word write is executed by a two-cycle command sequence. Word write setup (standard 40H or alternate 10H) is written, followed by a second write that specifies the address and data. The WSM then takes over, controlling the word write and write verify algorithms internally. After the word write sequence is written, the device automatically outputs status register data when read (see Figure 6). The CPU can detect the completion of the word write event by analyzing the status register bit SR.7.

When word write is complete, status register bit SR.4

should be checked. If word write error is detected, the status register should be cleared. The internal WSM verify only detects errors for "1"s that do not successfully write to "0"s. The CUI remains in read status register mode until it receives another command.

Reliable word writes can only occur when $VCC=2.7V \sim 3.6V$ and $VPP=VPP1/2$. If VPP is not within acceptable limits, the WSM doesn't execute the program command. If word write is attempted while $VPP \leq VPPLK$, status register bits SR.3 and SR.4 will be set to "1". Successful word write requires for boot sector that WP is VIH the corresponding sector lock-bit be cleared. In parameter and main sectors case, it must be cleared the corresponding sector lock-bit. If word write is attempted when the excepting above sector being clocked conditions, SR.1 and SR.4 will be set to "1". Word write is not functional.

4.7 Sector Erase Suspend Command

The Sector Erase Suspend command (50H) allows sector-erase interruption to read or word write data in another sector of memory. Once the sector erase process starts, writing the Sector Erase Suspend command requests that the WSM suspend the sector erase sequence at a predetermined point in the algorithm. The device outputs status register data when read after the Sector Erase Suspend command is written. Polling status register bits SR.7 and SR.6 can determine when the sector erase operation has been suspended (both will be set to "1"). Specification tWHRH2/tEHRH2 defines the sector erase suspend latency.

When Sector Erase Suspend command is written to the CUI, if sector erase was finished, the device would be placed read array mode. Therefore, after Sector Erase Suspend command is written to the CUI, Read Status Register command (70H) has to be written to CUI, then status register bit SR.6 should be checked if/when the device is in suspend mode.

At this point, a Read Array command can be written to read data from sectors other than that which is suspended. A Word Write commands sequence can also be issued during erase suspend to program data in other sectors. Using the Word Write Suspend command (see Section 4.9), a word write operation can also be suspended. During a word write operation with sector erase suspended, status register bit SR.7 will return to "0".

However, SR.6 will remain "1" to indicate sector erase suspend status.

The only other valid commands while sector erase is suspended are Read Status Register, Read Configuration, Read Query, Program Setup, Program Resume, Sector Lock, Sector Unlock, Sector Lock-Down and sector erase Resume. After a Sector Erase Resume command is written to the flash memory, the WSM will continue the sector erase process. Status register bits SR.6 and SR.7 will automatically be cleared. After the Erase Resume command is written, the device automatically outputs status register data when read (see Figure 9). VPP must remain at VPP1/2 while sector erase is suspended. RP must also remain at VIH (the same RP level used for sector erase). Sector cannot resume until word write operations initiated during sector erase suspend has completed.

If the time between writing the Sector Erase Resume command and writing the Sector Erase Suspend command is shorter than 15ms and both commands are written repeatedly, a longer time is required than standard sector erase until the completion of the operation.

4.8 Word Write Suspend Command

The Word Write Suspend command allows word write interruption to read data in other flash memory locations. Once the word write process starts, writing the Word Write Suspend command requests that the WSM suspend the Word write sequence at a predetermined point in the algorithm. The device continues to output status register data when read after the Word Write Suspend command is written. Polling status register bits SR.7 and SR.2 can determine when the word write operation has been suspended (both will be set to "1"). Specification t_{WHRH1}/t_{EHRH1} defines the word write suspend latency.

When Word Write Suspend command write to the CUI, if word write was finished, the device places read array mode. Therefore, after Word Write Suspend command write to the CUI, Read Status Register command (70H) has to be written to CUI, then status register bit SR.2 should be checked for if/when the device is in suspend mode.

At this point, a Read Array command can be written to read data from locations other than that which is suspended. The only other valid commands while word write

is suspended are Read Status Register Read Configuration, Read Query and Word Write Resume. After Word Write Resume command is written to the flash memory, the WSM will continue the Word write process. Status register bits SR.2 and SR.7 will automatically be cleared. After the Word Write Resume command is written, the device automatically outputs status register data when read (see Figure 7). VPP must remain at VPP1/2 while in word write suspend mode. RP must also remain at VIH (the same RP level used for word write).

If the time between writing the Word Write Resume command and writing the Word Write Suspend command is short and both commands are written repeatedly, a longer time is required than standard word write until the completion of the operation.

4.9 Sector Lock/Unlock /Lockdown Command

4.9.1 Sector Locked State

The default status of all sectors upon power-up or reset is locked. Any attempt on program or erase operations will result in an error on bit SR.1 of a locked sector. The status of a locked sector can be changed to unlocked or lock-down using software commands. An unlocked sector can be locked by writing the sector lock command sequence, 60H followed by 01H.

4.9.2 Sector Unlocked State

An unlocked sector can be programmed or erased. All unlocked sector return to the locked state when the device is either reset or powered down. The status of an unlocked sector can be changed to locked or locked-down using software commands. A locked sector can be unlocked by writing unlock command sequence, 60H followed by D0H.

4.9.3 Sector Locked-Down State

Sectors which are locked-down are protected from program and erase operation; however, the protection status of these sectors cannot be changed using software commands alone. Any sector locked or unlocked can be locked-down by writing the lock-down command sequence, 60H followed by 2FH. When the device is reset or powered down, the locked-down sectors will revert to the locked state.

The status of \overline{WP} will determine the function of sector lock-down and is summarized as followed:

\overline{WP}	Sector Lock-down Description
$\overline{WP}=0$	- sectors are protected from program, erase, and lock status changes
$\overline{WP}=1$	- the sector lock-down function is disabled - an individual lock-down sector can be unlocked and relocked via software command. Once \overline{WP} goes low, sectors that previously locked-down returns to lock-down state regardless of any changes when \overline{WP} was high.

In addition, sector lock-down is cleared only when the device is reset or powered down.

4.9.4 Read Sector Lock Status

The lock status of every sector can be read through Read Configuration mode. To enter this mode, first command write 90H to the device. The subsequent reads at sector address +00002 will output the lock status of this sector. The lock status can be read from the lowest two output pins DQ0 and DQ1. DQ0, DQ0 indicates the sector lock/unlock status and set by the lock command and cleared by the unlock command. When entering lock-down, the lock status is automatically set. DQ1 indicates lock-down status and is set by the lock-down command. It cannot be further cleared by software, only by device reset or power-down.

Sector Lock Configuration Table

Lock Status	Data
Sector is unlocked	DQ0=0
Sector is locked	DQ0=1
Sector is locked-down	DQ1=1

4.9.5 Sector Locking while Erase Suspend

The sector lock status can be performed during an erase suspend by using standard locking command sequences to unlock, lock, or lock-down a sector.

In order to change sector locking during an erase operation, the write erase suspend command (B0H) is placed first; then check the status register until it is shown that the actual erase operation has been suspended. Subsequent writing the desired lock command sequence to a sector and the lock status will be changed. When completing any desired lock, read or program operation, resume the erase operation with the Erase Resume Command (D0H).

If a sector is locked or locked-down during the same

sector is being placed in erase suspend, the locking status bits will be changed immediately, but when the erase is resumed, the erase operation will complete.

Locking operation cannot be performed during a program suspend.

4.9.6 Status Register Error Checking

The operation of locking system for this device can be used the term "state (X,Y,Z)" to specify locking status, where X=value of \overline{WP} , Y=bit DQ1 of the sector lock status register, and Z=bit DQ0 of the sector lock status register. DQ0 indicates if a sector is locked (1) or unlocked (0). DQ1 indicates if a sector has been locked-down(1) or not (0).

Table 5. Sector Locking State Transitions

Current State (X, Y, Z)=				Erase/Prog. Operation if Enable ?	Lock Command Input Result (Next State) (X, Y, Z)=		
\overline{WP}	DQ1	DQ0	Name		Lock	Unlock	Lock-Down
0	0	0	Unlocked	Yes	(001)	Unchanged	(011)
0	0	1	Locked (default)	No	Unchanged	(000)	(011)
0	1	1	Locked-Down	No	Unchanged	Unchanged	Unchanged
1	0	0	Unlocked	Yes	(101)	Unchanged	(111)
1	0	1	Locked	No	Unchanged	(100)	(111)
1	1	0	Lock-Down Disabled	Yes	(111)	Unchanged	(111)
1	1	1	Lock-Down Disabled	No	Unchanged	(110)	Unchanged

Note:

At power-up or device reset, all sectors default to locked state (001) (if $\overline{WP}=0$). Holding $\overline{WP}=0$ is the recommended default.

Table 6. Status Register Definition

WSMS	SESS	ES	PS	VPPS	PSS	SLS	R
7	6	5	4	3	2	1	0

- SR.7 = WRITE STATE MACHINE STATUS (WSMS)
 1 = Ready
 0 = Busy
- SR.6 = SECTOR ERASE SUSPEND STATUS (SESS)
 1 = Sector ERASE Suspended
 0 = Sector Erase in Progress/Completed
- SR.5 = ERASE STATUS (ES)
 1 = Error in Programming
 0 = Successful Sector Erase or Clear Sector Lock-Bits
- SR.4 = PROGRAM STATUS (PS)
 1 = Error in Programming
 0 = Successful Programming
- SR.3 = VPP STATUS (VPPS)
 1 = VPP Low Detect, Operation Abort
 0 = VPP OK
- SR.2 = PROGRAM SUSPEND STATUS (PSS)
 1 = Program Suspended
 0 = Program in Progress/Completed
- SR.1 = SECTOR LOCK STATUS (SLS)
 1 = Program/Erase attempted on a locked sector; operation aborted
 0 = No operation to locked sectors
- SR.0 = RESERVED FOR FUTURE ENHANCEMENTS (R)
- NOTES:**
 Check WSM bit first to determine word program or sector Erase completion, before checking Program or Erase Status bits.
- When Sector Erase Suspend is issued, WSM halts execution and sets both WSMS and SESS bits to "1". SESS bit remains set to "1" until an Sector Erase Resume command is issued.
- When this bit (SR.5) is set to "1", it means WSM is unable to verify successful sector erasure.
- When this bit is set to "1", WSM has attempted but failed to program a word.
- The WSM interrogates VPP level only after the Program or Erase command sequences have been entered and informs the system if VPP has not been switched on. SR.3 bit is not guaranteed to report accurate feedback between VPPLK and VPP1 min.
- When program suspend is issued, WSM halts the execution and sets both WSMS and PSS bits to "1". SR.2 remains set to "1" until a Program Resume command is issued.
- If a program or erase operation is attempted to one of the locked sectors, this bit is set by the WSM. The operation specified is aborted and the device is returned to read status mode.
- SR. 0 is reserved for future use and should be masked out when polling the status register.

5. 128-Bit Protection Register

The 128 bits of protection register are divided into two 64-bit segments. One of the segments is programmed at MXIC side with unique 64-bit number; where changes are forbidden. The other segment is left empty for customer to program. Once the customer segment is programmed, it can be locked to prevent further reprogramming.

5.1 Protection Register Read & Programming

The protection register is read in the configuration read mode, which follows the stated Command Bus Definitions.

The device is switched to this read mode by writing the Read Configuration command (90H). Once in this mode,

read cycles from addresses shown in Table 7 will retrieve the specified information. To return to read array mode, write the Read Array Command (FFH).

Two-cycle Protection Program Command is used to program protection register bits. The 64-bit number is programmed 16 bits at a time. First, write C0H Protection Program Setup command. The next write to the device will latch in address and data and program the specified location. The allowable address are also shown in Table 7. Refer to Figure 11 for the Protection Register Programming Flowchart.

Any attempt to address Protection Program command onto undefined protection register address space will result in a Status Register error (SR.4 set to "1"). In addition, attempting to program to a previously locked protection register segment will result in a status register error (SR.4=1, SR.1=1).

Table 7. Word-Wide Protection Register Addressing

Word	User	A7	A6	A5	A4	A3	A2	A1	A0
Lock	Both	1	0	0	0	0	0	0	0
0	Factory	1	0	0	0	0	0	0	1
1	Factory	1	0	0	0	0	0	1	0
2	Factory	1	0	0	0	0	0	1	1
3	Factory	1	0	0	0	0	1	0	0
4	Customer	1	0	0	0	0	1	0	1
5	Customer	1	0	0	0	0	1	1	0
6	Customer	1	0	0	0	0	1	1	1
7	Customer	1	0	0	0	1	0	0	0

- Notes: 1. Set address bit A19-A15=1 for TOP Boot device.
 2. Set address bit A19-A15=0 for Bottom Boot device.
 3. The address not specified in above are don't care.

5.2 Protection Register Locking

The user-programmable segment of the protection register is lockable by programming Bit 1 of the PR-Lock location to 0. Bit 0 of this location is programmed to 0 at MXIC to protect the unique device number. This bit is set using the protection program command to program "FFFD" to PR-LOCK location. After these bits have been programmed, no further changes can be made to the value stored in the protection register. Protection Program command to a locked section will result in a status register error (Program Error bit SR.4 and Lock Error bit SR.1 will be set to 1). Protection register lockout state is not reversible.

Table 8. Protection Register Memory Map

Protection Register Bit Address	Purpose
88H~85H	4 words User Program Register
84H~81H	4 words Factory Program Register
80H(Bit0 & Bit1)	Protection Register Lock



6 ELECTRICAL SPECIFICATIONS

6.1 ABSOLUTE MAXIMUM RATINGS

Operating Temperature

During Read, Sector Erase, Word

Write -40°C to +85°C

Storage Temperature -65°C to +125°C

Voltage on Any Pin (except VCC and

VPP) with respect to GND -0.5 V to +3.7V⁽¹⁾

VPP Supply Voltage (for Sector Erase and Word Write)

with respect to GND -0.5V to +13.5V^(1,2,4)

VCC and VCCQ Supply Voltage

with respect to GND. -0.2V to +3.6V⁽¹⁾

Output Short Circuit Voltage 100mA⁽³⁾

WARNING: Stressing the device beyond the "Absolute

Maximum Ratings" may cause permanent damage. These are stress ratings only. Operation beyond the "Operating Conditions" is not recommended and extended exposure beyond the "Operation Conditions" may affect device reliability.

1. Minimum DC voltage is -0.5V on input/output pins. During transitions, this level may undershoot to -2.0V for periods <20ns. Maximum DC voltage on input/output pins to VCC+0.5V which during transition; may overshoot to VCC+2.0V for periods <20ns.
2. Maximum DC voltage on VPP may overshoot to +14.0V for periods <20ns.
3. Output shorted for no more than one second. No more than one output shorted at a time.
4. VPP voltage is normally 1.65V~3.6V. Connection to supply of 11.4V~12.6V can only be done for 1000 cycles on the main sectors and 2500 cycles on the parameter sectors during program/erase. VPP may be connected to 12V for a total of 80 hours maximum.

6.2 Operating Conditions (Temperature and VCC Operating Conditions)

Symbol	Parameter	Min.	Max.	Unit	Notes
TA	Operating Temperature	-40	+85	°C	
VCC1	VCC Supply Voltage	2.7	3.6	V	1
VCCQ	I/O Supply Voltage	2.7	3.6	V	1
VPP1	Supply Voltage	1.65	3.6	V	1
VPP2	Supply Voltage	11.4	12.6	V	1,2
Cycling	Sector Erase Cycling	100,000			2

NOTE:

- 1.VCC and VCCQ must share the same supply when they are in the VCC1 range.
- 2.Applying VPP=11.4~12.6V during a program/erase can only be done for a maximum of 1000 cycles on the main sectors and 2500 cycles on the parameter sectors. VPP may be connected to 12V for a total of 80 hours maximum.

6.2.1 Capacitance ⁽¹⁾ (TA=+25°C, f=1MHz)

Symbol	Parameter	Typ.	Max.	Unit	Test Condition
CIN	Input Capacitance	6	8	pF	VIN=0.0V
COUT	Output Capacitance	10	12	pF	VOU=0.0V

NOTE:

- 1.Sampled, not 100% tested.

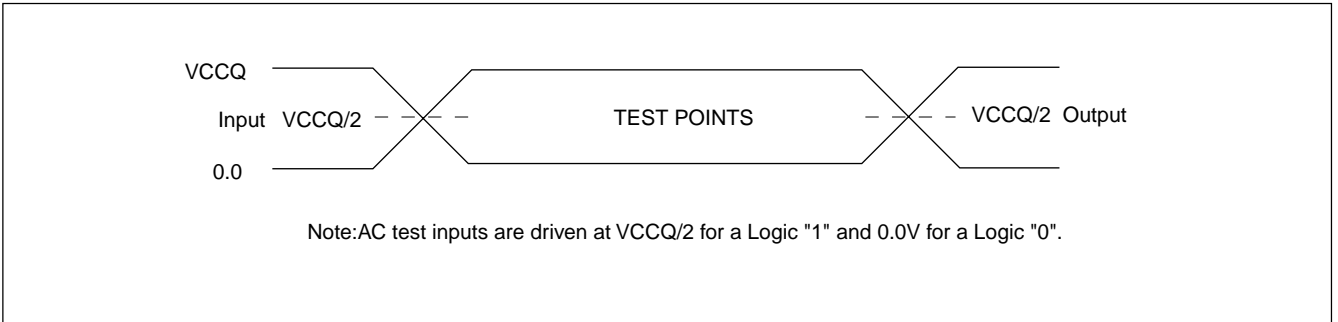
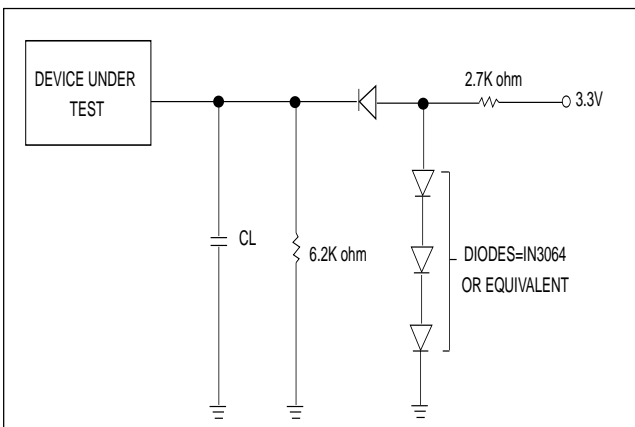
6.2.2 AC Input/Output Test Conditions

Figure 1. Transient Input/Output Reference Waveform
Figure 2. SWITCHING TEST CIRCUITS

TEST SPECIFICATIONS

Test Condition	70	90	110	Unit
Output Load	1 TTL gate			
Output Load Capacitance, CL (including jig capacitance)	30	100	100	pF
Input Rise and Fall Times	5			ns
Input Pulse Levels	0.0-3.0			V
Input timing measurement reference levels	1.5			V
Output timing measurement reference levels	1.5			V



6.2.3 AC Characteristic -- Read Only Operation (1)

Sym.	Parameter	Notes	-70		-90		-110		Unit
			Min.	Max.	Min.	Max.	Min.	Max.	
tAVAV	Read Cycle Time		70		90		110	ns	
tAVQV	Address to Output Delay			70		90		110	ns
tELQV	\overline{CE} to Output Delay	2		70		90		110	ns
tGLQV	\overline{OE} to Output Delay	2		20		30		30	ns
tPHQV	\overline{RP} to Output Delay			150		150		150	ns
tELQX	\overline{CE} to Output in Low Z	3	0		0		0		ns
tGLQX	\overline{OE} to Output in Low Z	3	0		0		0		ns
tEHQZ	\overline{CE} to Output in High Z	3		20		20		20	ns
tGHQZ	\overline{OE} to Output in High Z	3		20		20		20	ns
tOH	Output Hold from Address, \overline{CE} , or \overline{OE} Change, Whichever Occurs First	3	0		0		0		ns

Notes:

- 1. See AC Waveform: Read Operations at Figure 3.
- 2. \overline{OE} may be delayed up to tELQV-tGLQV after the falling edge of \overline{CE} without impact on tELQV.
- 3. Sampled, but not 100% tested.
- 4. See test Configuration.

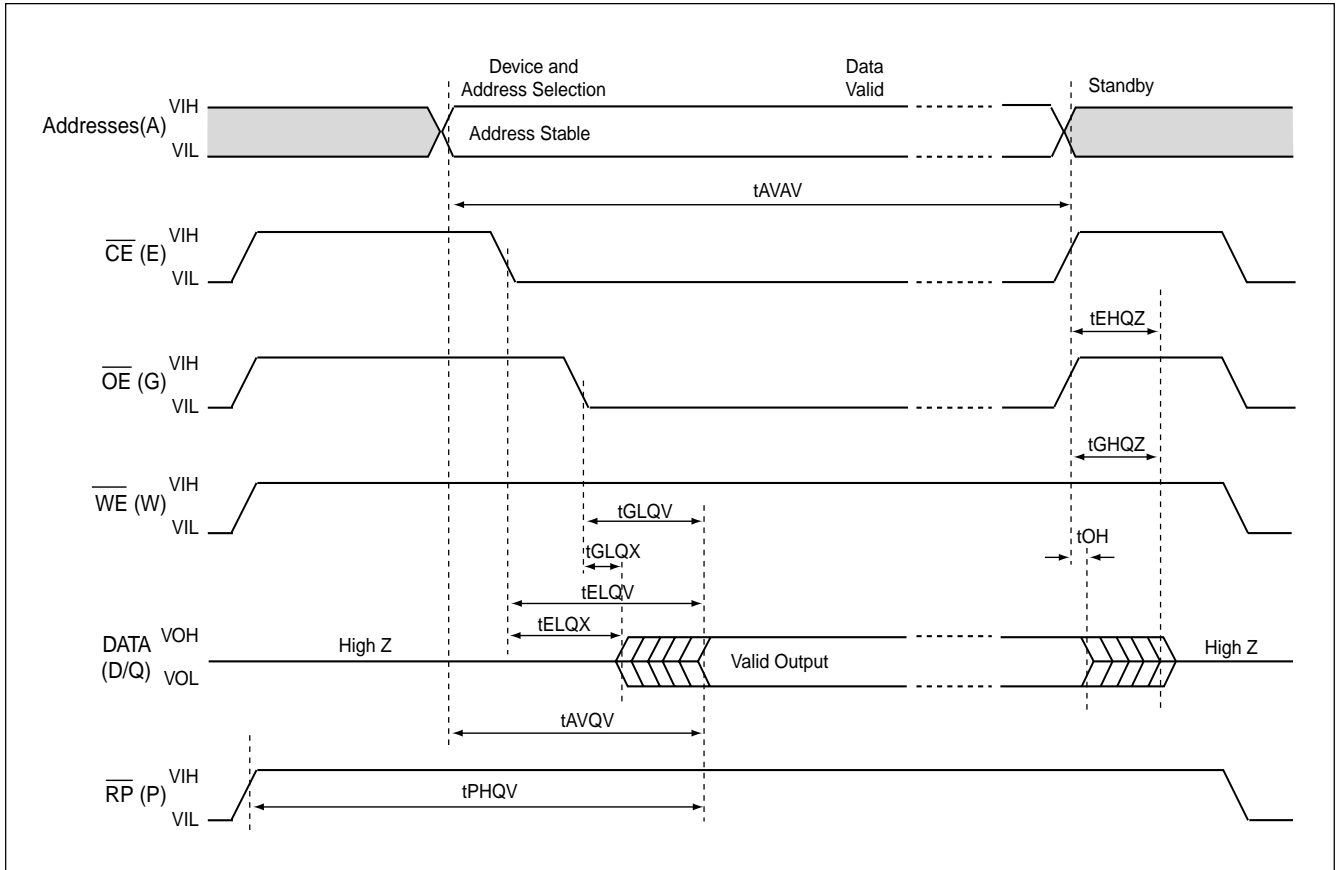
Figure 3. READ-ONLY OPERATION AC WAVEFORM

**6.2.5 AC Characteristic -- Write Operation**

Sym.	Parameter	Note	-70	-90	-110	Unit
			Min.	Min.	Min.	
tPHWL/tPHEL	RP High Recovery to $\overline{WE}(\overline{CE})$ Going Low		150	150	150	ns
tELWL/tWLEL	$\overline{CE}(\overline{WE})$ Setup to $\overline{WE}(\overline{CE})$ Going Low		0	0	0	ns
tWLWH/tELEH	$\overline{WE}(\overline{CE})$ Pulse Width	4	45	60	70	ns
tDVWH/tDVEH	Data Setup to $\overline{WE}(\overline{CE})$ Going High	2	40	50	60	ns
tAVWH/tAVEH	Address Setup to $\overline{WE}(\overline{CE})$ Going High	2	50	60	70	ns
tWHEH/tEHWL	$\overline{CE}(\overline{WE})$ Hold Time from $\overline{WE}(\overline{CE})$ High		0	0	0	ns
tWHDX/tEHDX	Data Hold Time from $\overline{WE}(\overline{CE})$ High	2	0	0	0	ns
tWHAX/tEHAX	Address Hold Time from $\overline{WE}(\overline{CE})$ High	2	0	0	0	ns
tWHWL/tEHEL	$\overline{WE}(\overline{CE})$ Pulse Width High	4	25	30	30	ns
tVPWH/tVPEH	VPP Setup to $\overline{WE}(\overline{CE})$ Going High	3	200	200	200	ns
tQVVL	VPP Hold from Valid SRD	3	0	0	0	ns
tBHWL/tBHEH	\overline{WP} Setup to $\overline{WE}(\overline{CE})$ Going High	3	0	0	0	ns
tQVBL	\overline{WP} Hold from Valid SRD	3	0	0	0	ns
tWHGL	\overline{WE} High to \overline{OE} Going Low	3	30	30	30	ns

Notes:

1. Write timing characteristics during erase suspend are the same as during write-only operations.
2. Refer to Table 5 for valid AIN or DIN.
3. Sampled, not 100% tested.
4. Write pulse width (tWP) is defined from \overline{CE} or \overline{WE} going low (whichever goes low last) to \overline{CE} or \overline{WE} going high (whichever goes high first). Hence, $tWP=tWLWH=tELEH=tWLEH=tELWH$. Similarly, Write pulse width high (tWPH) is defined from \overline{CE} or \overline{WE} going high (whichever goes high first) to \overline{CE} or \overline{WE} going low (whichever goes low first). Hence, $tWPH=tWHWL=tEHEL=tWHEL=tEHWL$.
5. See Test Configuration.

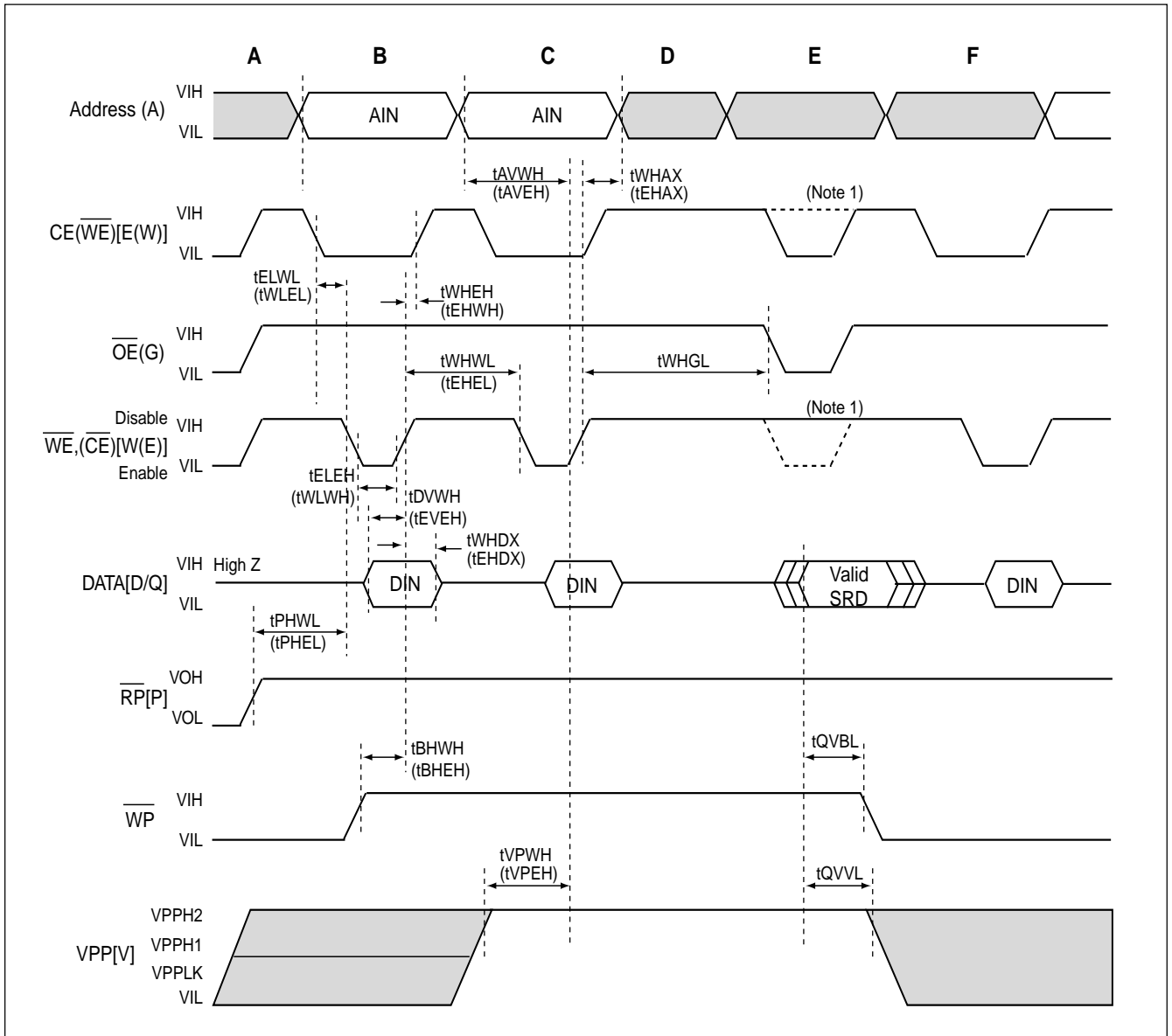
Figure 4. WRITE AND ERASE OPERATION AC WAVEFORM

Notes:

1. CE must be toggled low when reading Status Register Data. WE must be inactive (high) when reading Status Register Data.
- A. VCC Power-Up and Standby.
- B. Write Program or Erase Setup Command.
- C. Write Valid Address and Data (for Program) or Erase Confirm Command.
- D. Automated Program or Erase Delay.
- E. Read Status Register Data (SRD): reflects completed program/erase operation.
- F. Write Read Array Command.



6.2.5 Erase and Program Timing (1)

Symbol	Parameter	Vpp Note	1.65V-3.6V		11.4V-12.6V		Unit
			Typ(1)	Max	Typ(1)	Max	
tBWPB	4-KW Parameter Sector Word Program Time	2,3	0.10	0.30	0.03	0.12	s
tBWMB	32-KW Main Sector Word Program Time	2,3	0.8	2.4	0.24	1	s
tWHQV1/ tEHQV1	Word Program Time	2,3	12	200	8	185	us
tWHQV2/ tEHQV2	4-KW Parameter Sector Erase Time	2,3	0.5	4	0.4	4.0	s
tWHQV3/ tEHQV3	32-KW Main Sector Erase Time	2,3	1	5	0.6	5	s
tWHRH1/ tEHRH1	Program Suspend Latency	3	15	20	15	20	us
tWHRH2/ tEHRH2	Erase Suspend Latency	3	15	20	15	20	us

Notes:

- 1. Typical values measured at TA=+25° C and nominal voltage.
- 2. Excludes external system-level overhead.
- 3. Sampled, but not 100% tested.

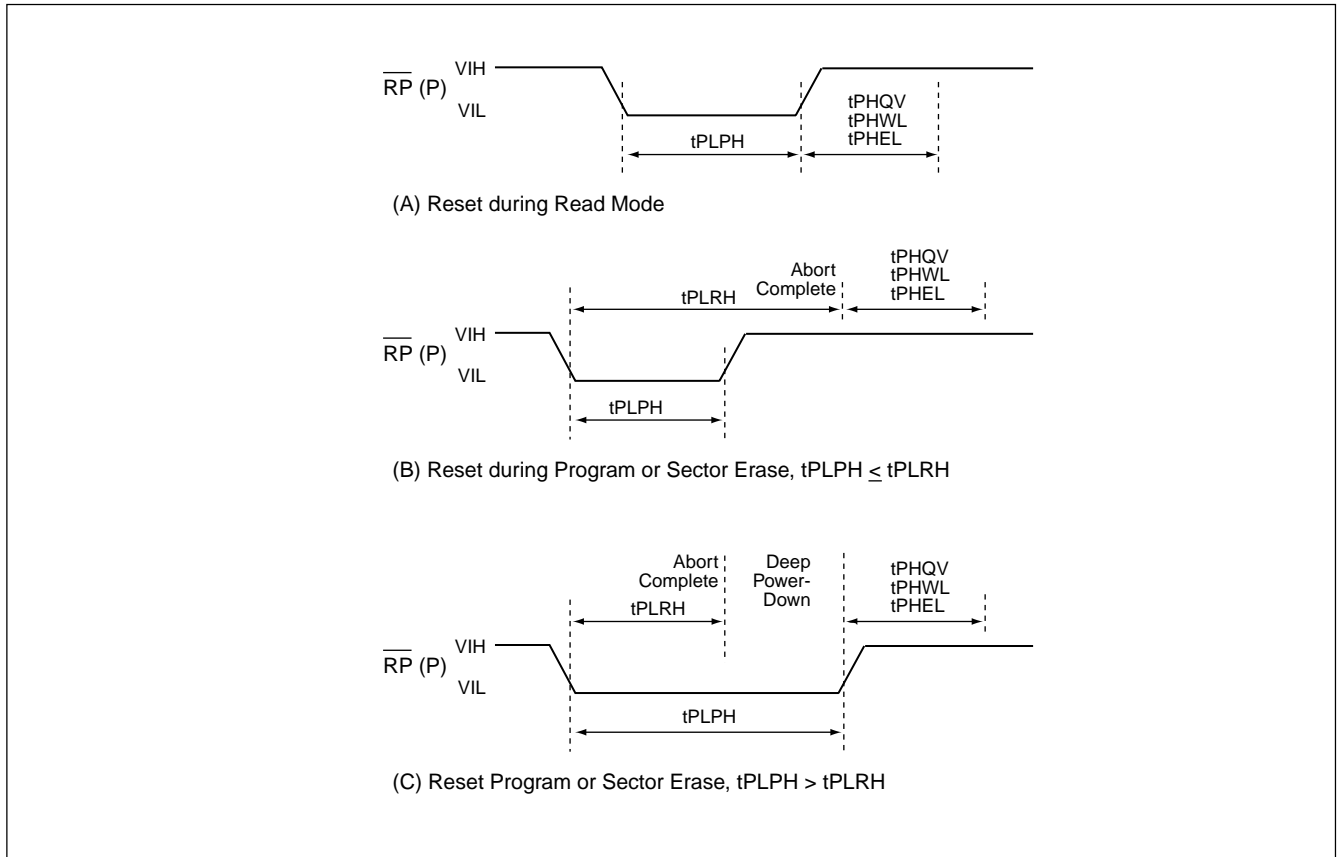
Figure 5. RESET WAVEFORM

AC Characteristic -- Under Reset Operation

Sym.	Parameter	VCC=2.7V~3.6V		Unit	Notes
		Min.	Max.		
tPLPH	\overline{RP} Low to Reset during Read (If \overline{RP} is tied to VCC, this specification is not applicable)	100		ns	1,3
tPLRH1	\overline{RP} Low to Reset during Sector Erase		22	us	1,4
tPLRH2	\overline{RP} Low to Reset during Program		12	us	1,4

Notes:

1. See Section 3.4 for a full description of these conditions.
2. If tPLPH is < 100ns the device may still reset but this is not guaranteed.
3. If \overline{RP} is asserted while a sector erase or word program operation is not executing, the reset will complete within 100ns.
4. Sampled, but not 100% tested.

6.2.6 DC Characteristics

Sym.	Parameter	VCC	2.7V-3.6V		Unit	Test Conditions
		VCCQ	2.7V-3.6V			
		Note	Typ.	Max.		
ILI	Input Load Current	1,2		± 1	µA	VCC=VCC Max. ; VCCQ=VCCQ Max. VIN=VCCQ or GND
ILO	Output Leakage Current	1,2	0.2	± 10	µA	VCC=VCC Max. ; VCCQ=VCCQ Max. VIN=VCCQ or GND
ICCS	VCC Standby Current	1	7	15	µA	VCC=VCC Max. ; $\overline{CE}=\overline{RP}=VCCQ$ or during Program/Erase Suspend $\overline{WP}=VCCQ$ or GND
ICCD	VCC Power-Down Current	1,2	7	15	µA	VCC=VCC Max ; VCCQ=VCCQ Max VIN=VCCQ or GND $\overline{RP}=GND\pm 0.2V$
ICCR	VCC Read Current	1,2,3	9	18	mA	VCC=VCC Max ; VCCQ=VCCQ Max $\overline{OE}=VIH, \overline{CE}=VIL, f=5MHz, IO_{OUT}=0mA$ Inputs=VIL or VIH
IPPD	VPP Deep Power-Down Current	1	0.2	5	µA	$\overline{RP}=GND\pm 0.2V$ $VPP \leq VCC$
IPPR	VPP Read Current	1,4	2	±15	µA	$VPP \leq VCC$
			50	200	µA	$VPP > VCC$
ICCW+ IPPW	VCC+VPP Program Current	1,4	18	55	mA	$VPP=VPP1$, Program in Progress
			10	30	mA	$VPP=VPP2(12V)$, Program in Progress
ICCE+ IPPE	VCC+VPP Erase Current	1,4	21	45	mA	$VPP=VPP1$, Erase in Progress
			16	45	mA	$VPP=VPP2(12V)$, Erase in Progress
ICCES or ICCWS	VCC Program or Erase Suspend Current	1,4	7	15	µA	$\overline{CE}=VCC$, Program or Erase Suspend in Progress
VIL	Input Low Voltage		-0.4	$VCC*0.22V$	V	
VIH	Input High Voltage		2.0	$VCCQ+0.3V$	V	
VOL	Output Low Voltage		-0.1	0.1	V	VCC=VCC Min, VCC=VCCQ Min $IOL=100\mu A$
VOH	Output High Voltage		VCCQ -0.1V		V	VCC=VCC Min, VCC=VCCQ Min $IOH=-100\mu A$
VPPLK	VPP Lock-Out Voltage	6		1.0	V	Complete Write Protection
VPP1	VPP during Program/	6	1.65	3.6	V	
VPP2	Erase Operations	6	11.4	12.6	V	
VLKO	VCC Prog/Erase Lock Voltage		1.5		V	
VLKO2	VCCQ Prog/Erase Lock Voltage		1.2		V	



Notes:

1. All currents are in RMS unless otherwise noted. Typical values at nominal VCC, TA=+25° C.
2. The test conditions VCC Max, VCCQ Max, VCC Min, and VCCQ Min refer to the maximum or minimum VCC or VCCQ voltage listed at the top of each column.
3. Power Savings (Mode) reduces ICCR to approximately standby levels in static operation (CMOS inputs).
4. Sampled, but not 100% tested.
5. ICCES and ICCWS are specified with device de-selected. If device is read while in erase suspend, current draw is sum of ICCES and ICCR. If the device is read while in program suspend, current draw is the sum of ICCWS and ICCR.
6. Erase and Program are inhibited when $VPP < VPPLK$.

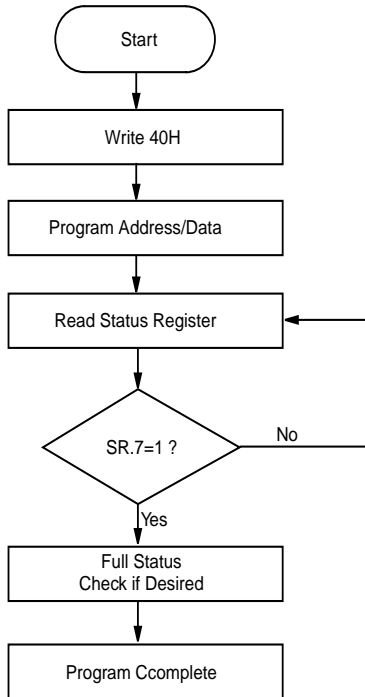
Figure 6. Automated Word Programming Flowchart

Bus Operation	Command	Comments
Write	Program Setup	Data=40H
Write	Program	Data=Data to Program Addr=Location to Program
Read		Status Register Data Toggle CE or OE to Update Status Register Data
Standby		Check SR.7 1=WSM Ready 0=WSM Busy
Repeat for subsequent programming operations. SR full status check can be done after each program or after a sequence of program operations. Write FFH after the last program operation to reset device to read array mode.		

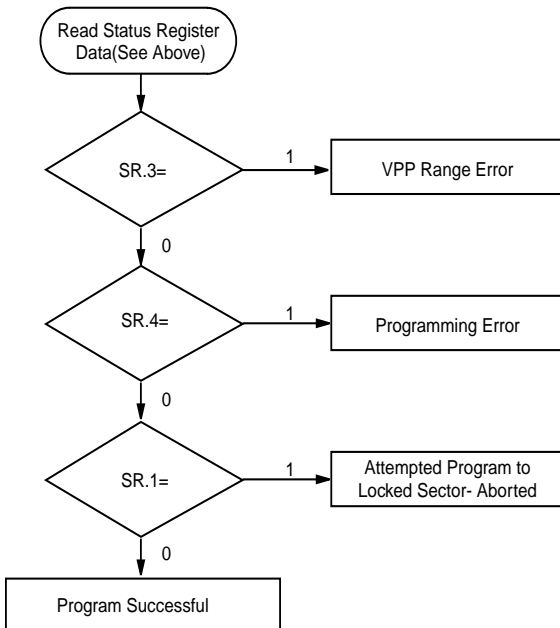
FULL STATUS CHECK PROCEDURE

Bus Operation	Command	Comments
Standby		Check SR.3 1=VPP Low Detect
Standby		Check SR.4 1=VPP Program Error
Standby		Check SR.1 1=Attempted Program to Locked Sector-Program Aborted
SR.3 MUST be cleared, if set during a program attempt, before further attempts are allowed by the Write State Machine. SR.4, SR.3, and SR.1 are only cleared by the Clear Status Register Command, in cases where multiple bytes are programmed before full status is checked. If an error is detected, clear the status register before attempting retry or other error recovery.		

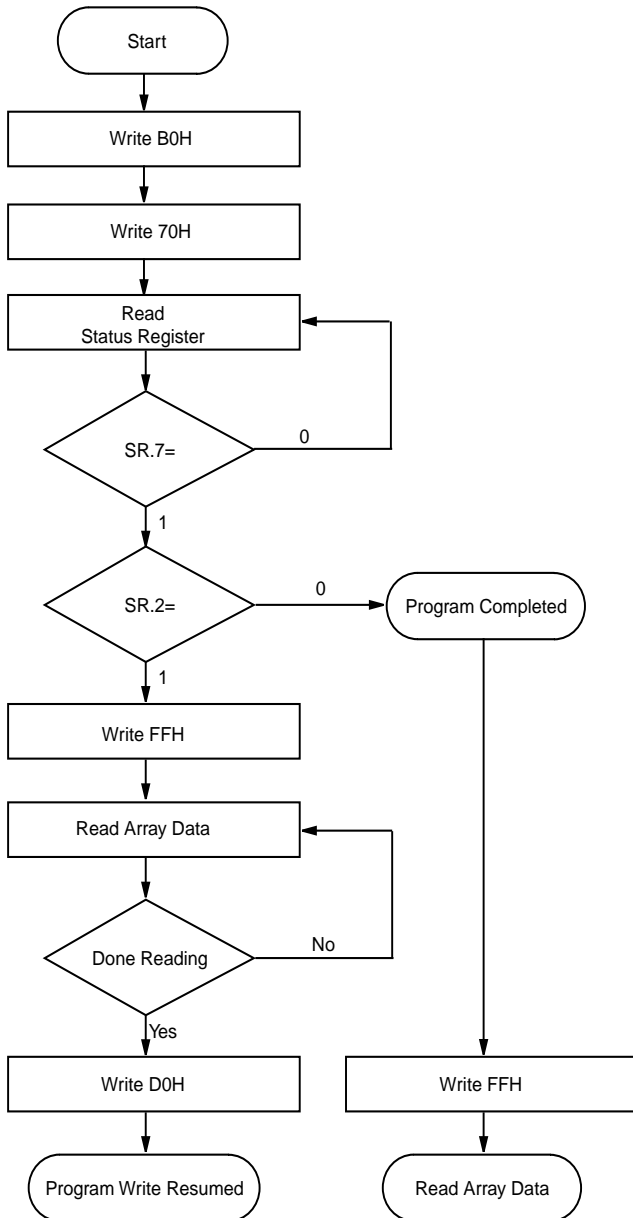
Figure 7. Program Suspend/Resume Flowchart

Bus Operation	Command	Comments
Write	Program Suspend	Data=B0H Addr=X
Write	Read Status	Data=70H Addr=X
Read		Status Register Data Toggle CE or OE to Update Status Register Data Addr=X
Standby		Check SR.7 1=WSM Ready 0=WSM Busy
Stanby		Check SR.2 1=Program Suspended 0=Program Completed
Write	Read Array	Data=FFH Addr=X
Read		Read array data from sector other than the one being programmed.
Write	Program Resume	Data=D0H Addr=X

Figure 8. Automated Sector Erase Flowchart

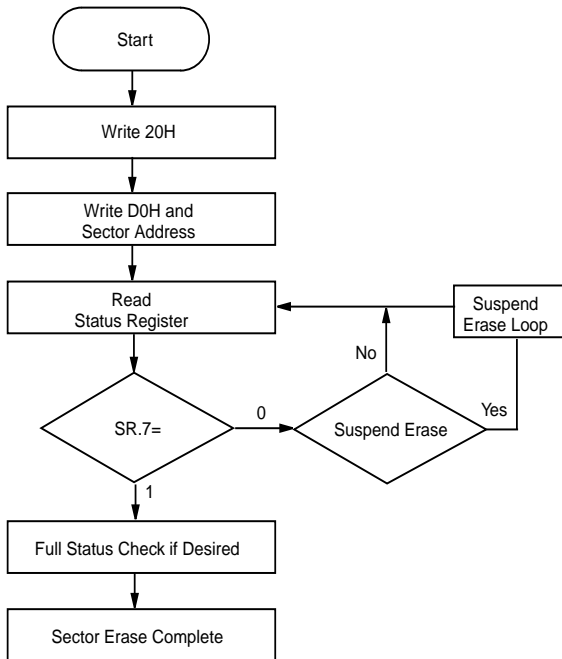

Bus Operation	Command	Comments
Write	Erase Setup	Data=20H Addr=Within Sector to Be Erased
Write	Erase Confirm	Data=D0H Addr=Within Sector to Be Erased
Read		Status Register Data Toggle \overline{CE} or \overline{OE} to Update Status Register Data
Standby		Check SR.7 1=WSM Ready 0=WSM Busy
Repeat for subsequent sector erasures. Full status check can be done after each sector erase or after a sequence of sector erasures. Write FFH after the last write operation to reset device to read array mode.		

FULL STATUS CHECK PROCEDURE

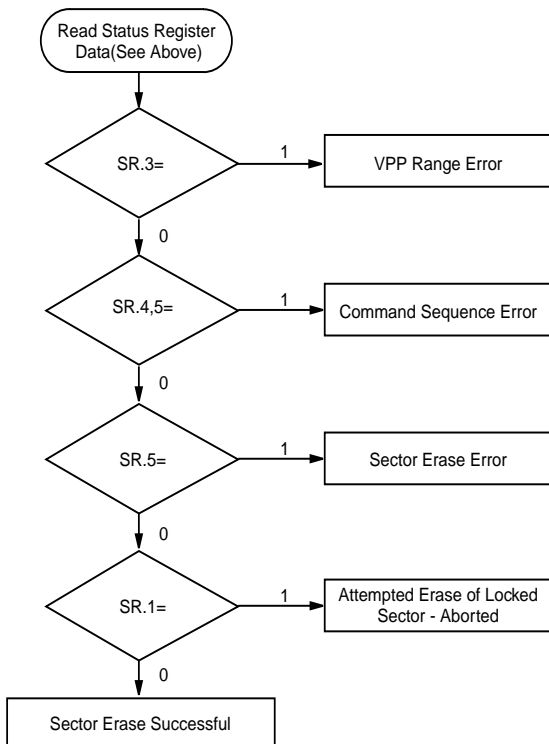

Bus Operation	Command	Comments
Standby		Check SR.3 1=VPP Low Detect
Standby		Check SR.4, 5 Both 1=Command Sequence Error
Standby		Check SR.5 1=Sector Erase Error
Standby		Check SR.1 1=Attempted Erase of Locked Sector- Erase Aborted
SR.1 and SR.3 MUST be cleared, if set during an erase attempt, before further attempts are allowed by the Write State Machine. SR.1,3,4,5 are only cleared by the Clear Status Register Command, in cases where multiple bytes are erased before full status is checked. If an error is detected, clear the status register before attempting retry or other error recovery.		

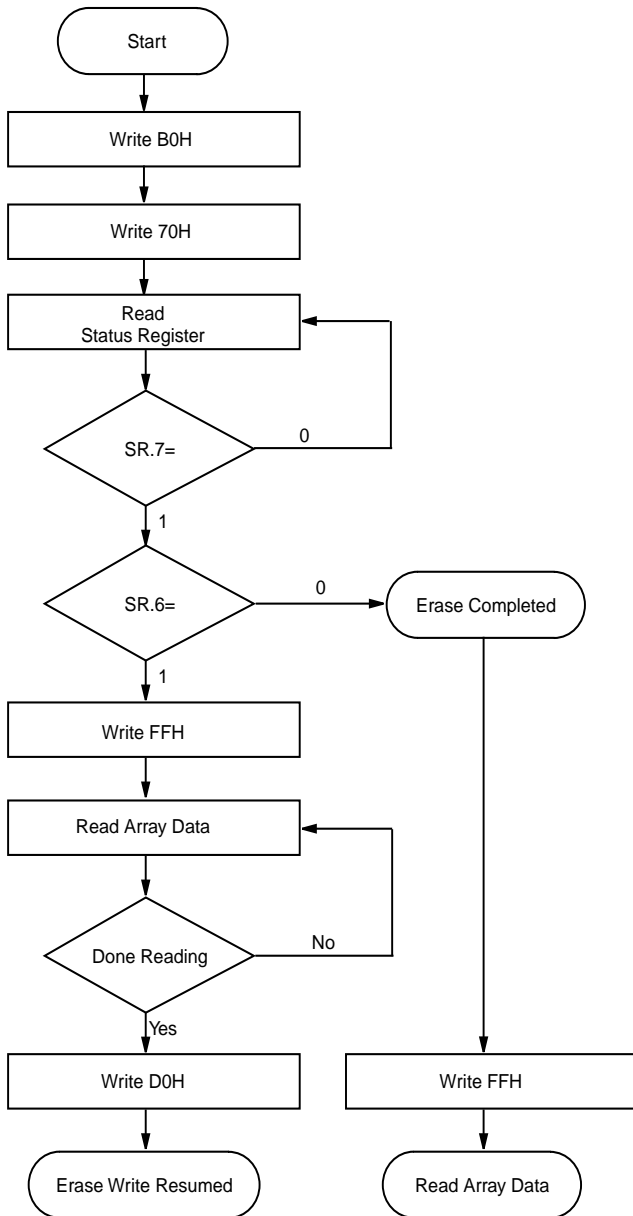
Figure 9. Erase Suspend/Resume Flowchart

Bus Operation	Command	Comments
Write	Erase Suspend	Data=B0H Addr=X
Write	Read Status	Data=70H Addr=X
Read		Status Register Data Toggle CE or OE to Update Status Register Data Addr=X
Standby		Check SR.7 1=WSM Ready 0=WSM Busy
Stanby		Check SR.6 1=Erase Suspended 0=Erase Completed
Write	Read Array	Data=FFH Addr=X
Read		Read array data from sector other than the one being erased.
Write	Erase Resume	Data=D0H Addr=X

Figure 10. Locking Operations Flowchart

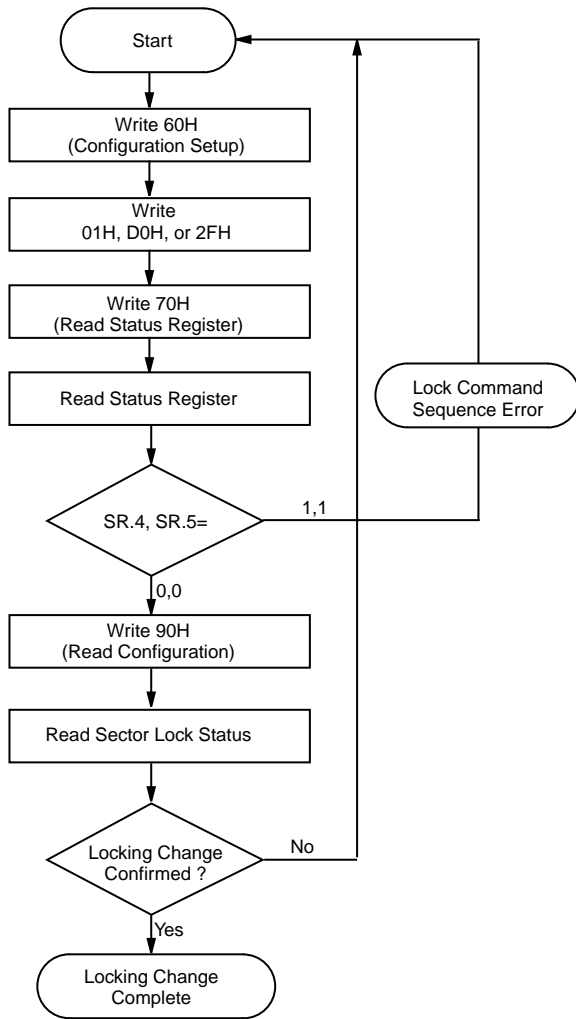

Bus Operation	Command	Comments
Write	Config. Setup	Data=60H Addr=X
Write	Lock, unlock or Lockdown	Data=01H (Sector Lock) D0H(Sector Unlock) 2FH(Sector Lockdown) Addr=Within sector to lock
Write (Optional)	Read Status Register	Data=70H Addr=X
Read (Optional)		Status Register Register Addr=X
Standby (Optional)		Check Status Register 80H=no error 30H=Lock Command Sequence Error
Write (Optional)	Read Configuration	Data=90H Addr=X
Read (Optional)	Sector Lock Status	Sector Lock Status Data Addr=Second addr of sector
Standby		Confirm Locking Change on DQ1, DQ0 (See Sector Locking State Table for valid combinations.)

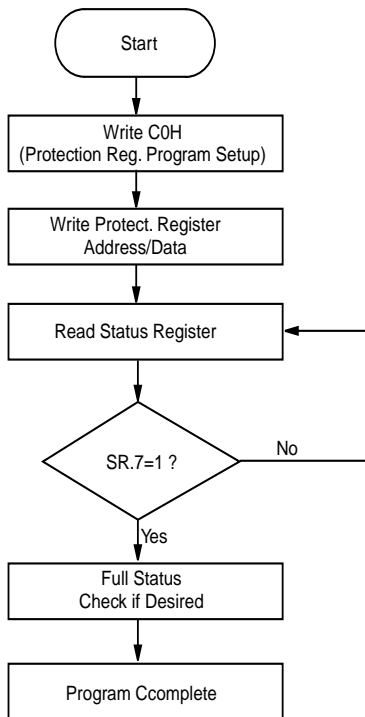
Figure 11. Protection Register Programming Flowchart

Bus Operation	Command	Comments
Write	Protection Program Setup	Data=C0H
Write	Protection Program	Data=Data to Program Addr=Location to Program
Read		Status Register Data Toggle CE or OE to Update Status Register Data
Standby		Check SR.7 1=WSM Ready 0=WSM Busy

Protection Program operations can only be addressed within the protection register address space. Addresses outside the defined space will return an error. Repeat for subsequent programming operations. SR Full Status Check can be done after each program or after a sequence of program operations. Write FFH after the last operation to reset device to read array mode.

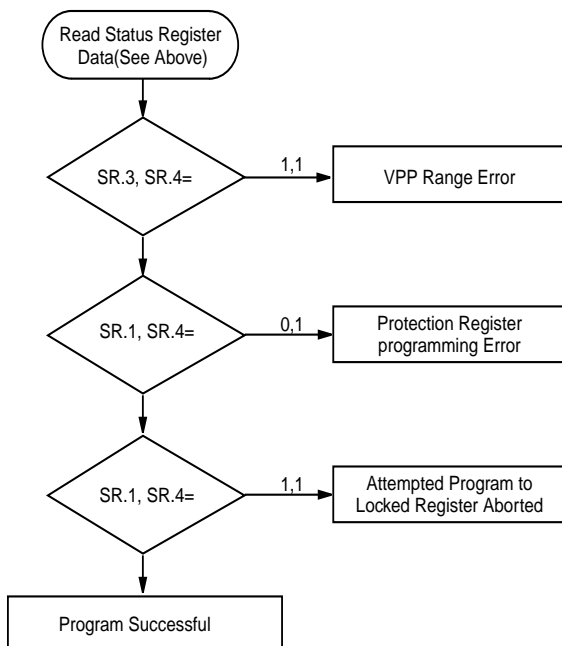
FULL STATUS CHECK PROCEDURE

Bus Operation	Command	Comments
Standby		SR.1, SR.3, SR.4 0 1 1 VPP Low
Standby		0 0 1 Prot. Reg. Prog. Error
Stanby		1 0 1 Register Locked: Aborted

SR.3 MUST be cleared, if set during a program attempt, before further attempts are allowed by the Write State Machine. SR.1,3,4 are only cleared by the Clear Status Register Command, in cases of multiple protection register program operations before full status is checked. If an error is detected, clear the status register before attempting retry or other error recovery.



7 VPP Program and Erase Voltage

MX28F160C3T/B product provides in-system programming and erase in the 1.65V~3.6V of VPP range. In addition, VPP pin on 12V provides fast production programming.

7.1 VPP Fast manufacturing Programming

When VPP is between 1.65V and 3.6V, all program and erase current is drawn through the VCC pin. If VPP is driven by a logic signal, $V_{IH}=1.65V$. That is, VPP must remain above 1.65V to perform in-system flash update/modifications. When VPP is connected to a 12V power supply, the device draws program and erase current directly from the VPP pin.

7.2 Protection Under $VPP < VPPLK$

VPP can off additional hardware write protection. The VPP programming voltage can be kept low for the absolute hardware protection of all sector in the flash device. As VPP is below VPPLK, any program or erase operation will result in a error, prompting the corresponding status register bit (SR.3) to be set.



8. QUERY COMMAND AND COMMON FLASH

INTERFACE (CFI) MODE

MX28F160C3T/B is capable of operating in the CFI mode. This mode allows the host system to determine the manufacturer of the device such as operating parameters and configuration. Two commands are required in CFI mode. Query command of CFI mode is placed first, then the Reset command exits CFI mode. These are described in Table 3.

The single cycle Query command is valid only when the device is in the Read mode, including Erase Suspend, Program Suspend, Standby mode, and Read ID mode; however, it is ignored otherwise.

The Reset command exits from the CFI mode to the Read mode, or Erase Suspend mode, Program Suspend or read ID mode. The command is valid only when the device is in the CFI mode.

Table 9-1. CFI mode: Identification Data Values

(All values in these tables are in hexadecimal)

Description	Address h	Data h
Query-unique ASCII string "QRY"	10	0051
	11	0052
	12	0059
Primary vendor command set and control interface ID code	13	0003
	14	0000
Address for primary algorithm extended query table	15	0035
	16	0000
Alternate vendor command set and control interface ID code (none)	17	0000
	18	0000
Address for secondary algorithm extended query table (none)	19	0000
	1A	0000

Table 9-2. CFI Mode: System Interface Data Values

Description	Address h	Data h
VCC supply, minimum (2.7V)	1B	0027
VCC supply, maximum (3.6V)	1C	0036
VPP supply, minimum (11.4V)	1D	00B4
VPP supply, maximum (12.6V)	1E	00C6
Typical timeout for single word write (2 ^N us)	1F	0005
Typical timeout for maximum size buffer write (2 ^N us)	20	0000
Typical timeout for individual sector erase (2 ^N ms)	21	000A
Typical timeout for full chip erase (2 ^N ms) (not supported)	22	0000
Maximum timeout for single word write times (2 ^N X Typ)	23	0004
Maximum timeout for maximum size buffer write times (2 ^N X Typ)	24	0000
Maximum timeout for individual sector erase times (2 ^N X Typ)	25	0003
Maximum timeout for full chip erase times (not supported)	26	0000



Table 9-3. CFI Mode: Device Geometry Data Values

Description	Address h	Data h
Device size (2 ⁿ bytes)	27	0015
Flash device interface code (asynchronous x16)	28	0001
	29	0000
Maximum number of bytes in write buffer=2 ⁿ (not supported)	2A	0000
	2B	0000
Number of erase sector regions within device (one or more continuous same-size erase sectors at one sector region)	2C	0002
		T B
Erase Sector Region 1 information	2D	1E 07
[2E,2D] = number of same-size sectors in region 1-1	2E	00 00
[30, 2F] = region erase sector size in multiples of 256-bytes	2F	00 20
	30	01 00
		T B
Erase Sector Region 2 information	31	07 1E
[32,31] = number of same-size sectors in region 2-1	32	00 00
[34,33] = region erase sector size in multiples of 256-bytes	33	20 00
	34	00 01



Table 9-4. CFI Mode: Primary Vendor-Specific Extended Query Data Values

Description	Address h	Data h
Query-unique ASCII string "PRI"	35	0050
	36	0052
	37	0049
Major version number, ASCII	38	0031
Minor version number, ASCII	39	0030
Optional Feature & Command Support	3A	66
bit 0 Chip Erase Supported (1=yes, 0=no)	3B	00
bit 1 Suspend Erase Supported (1=yes, 0=no)	3C	00
bit 2 Suspend Program Supported (1=yes, 0=no)	3D	00
bit 3 Lock/Unlock Supported (1=yes, 0=no)		
bit 4 Queued Erase Supported (1=yes, 0=no)		
bit 5 Instant individual sector locking supported (1=yes, 0=no)		
bit 6 Protection bits supported (1=yes, 0=no)		
bit 7 Page mode read supported (1=yes, 0=no)		
bit 8 Synchronous read support (1=yes, 0=no)		
bits 9-31 reserved for future use; undefined bits are "0"		
Supported functions after suspend	3E	01
bit 0 Program supported after erase suspend (1=yes, 0=no)		
bit 1-7 Reserved for other supported options; undefined bits are "0"		
Sector Lock Status	3F	03
Define which bits in the sector status Register section of the Query are implemented.	40	00
bit 0 sector Lock Status Register Lock/Unlock bit (bit 0) active; (1=yes, 0=no)		
bit 1 sector Lock Status Register Lock-Down bit (bit 1) active; (1=yes, 0=no)		
Bits 2-15 reserved for future use. Undefined bits are "0".		
VCC Logic Supply Optimum Program/Erase Voltage (highest performance)	41	33
bits 7-4 BCD value in volts		
bits 3-0 BCD value in 100mV		
VPP Supply Optimum Program/Erase Voltage	42	C0
bits 7-4 HEX value in volts		
bits 3-0 BCD value in 100mV		



ORDER INFORMATION

PART NO.	ACCESS TIME	OPERATING	STANDBY	PACKAGE
	(ns)	Read Current MAX.(mA)	Current MAX.(uA)	
MX28F160C3TTC-70	70	18	15	48 Pin TSOP
MX28F160C3BTC-70	70	18	15	48 Pin TSOP
MX28F160C3TTC-90	90	18	15	48 Pin TSOP
MX28F160C3BTC-90	90	18	15	48 Pin TSOP
MX28F160C3TTC-11	110	18	15	48 Pin TSOP
MX28F160C3BTC-11	110	18	15	48 Pin TSOP
MX28F160C3TTI-70	70	18	15	48 Pin TSOP
MX28F160C3BTI-70	70	18	15	48 Pin TSOP
MX28F160C3TTI-90	90	18	15	48 Pin TSOP
MX28F160C3BTI-90	90	18	15	48 Pin TSOP
MX28F160C3TTI-11	110	18	15	48 Pin TSOP
MX28F160C3BTI-11	110	18	15	48 Pin TSOP
MX28F160C3TXAC-70	70	18	15	48 Ball CSP
MX28F160C3BXAC-70	70	18	15	48 Ball CSP
MX28F160C3TXAC-90	90	18	15	48 Ball CSP
MX28F160C3BXAC-90	90	18	15	48 Ball CSP
MX28F160C3TXAC-11	110	18	15	48 Ball CSP
MX28F160C3BXAC-11	110	18	15	48 Ball CSP
MX28F160C3TXAI-70	70	18	15	48 Ball CSP
MX28F160C3BXAI-70	70	18	15	48 Ball CSP
MX28F160C3TXAI-90	90	18	15	48 Ball CSP
MX28F160C3BXAI-90	90	18	15	48 Ball CSP
MX28F160C3TXAI-11	110	18	15	48 Ball CSP
MX28F160C3BXAI-11	110	18	15	48 Ball CSP
MX28F160C3TTC-70G	70	18	15	48 Pin TSOP
MX28F160C3BTC-70G	70	18	15	48 Pin TSOP
MX28F160C3TTC-90G	90	18	15	48 Pin TSOP
MX28F160C3BTC-90G	90	18	15	48 Pin TSOP
MX28F160C3TTC-11G	110	18	15	48 Pin TSOP
MX28F160C3BTC-11G	110	18	15	48 Pin TSOP
MX28F160C3TTI-70G	70	18	15	48 Pin TSOP
MX28F160C3BTI-70G	70	18	15	48 Pin TSOP
MX28F160C3TTI-90G	90	18	15	48 Pin TSOP
MX28F160C3BTI-90G	90	18	15	48 Pin TSOP



MX28F160C3T/B

PART NO.	ACCESS TIME	OPERATING	STANDBY	PACKAGE
	(ns)	Read Current MAX.(mA)	Current MAX.(uA)	
MX28F160C3TTI-11G	110	18	15	48 Pin TSOP
MX28F160C3BTI-11G	110	18	15	48 Pin TSOP
MX28F160C3TXAC-70G	70	18	15	48 Ball CSP
MX28F160C3BXAC-70G	70	18	15	48 Ball CSP
MX28F160C3TXAC-90G	90	18	15	48 Ball CSP
MX28F160C3BXAC-90G	90	18	15	48 Ball CSP
MX28F160C3TXAC-11G	110	18	15	48 Ball CSP
MX28F160C3BXAC-11G	110	18	15	48 Ball CSP
MX28F160C3TXAI-70G	70	18	15	48 Ball CSP
MX28F160C3BXAI-70G	70	18	15	48 Ball CSP
MX28F160C3TXAI-90G	90	18	15	48 Ball CSP
MX28F160C3BXAI-90G	90	18	15	48 Ball CSP
MX28F160C3TXAI-11G	110	18	15	48 Ball CSP
MX28F160C3BXAI-11G	110	18	15	48 Ball CSP

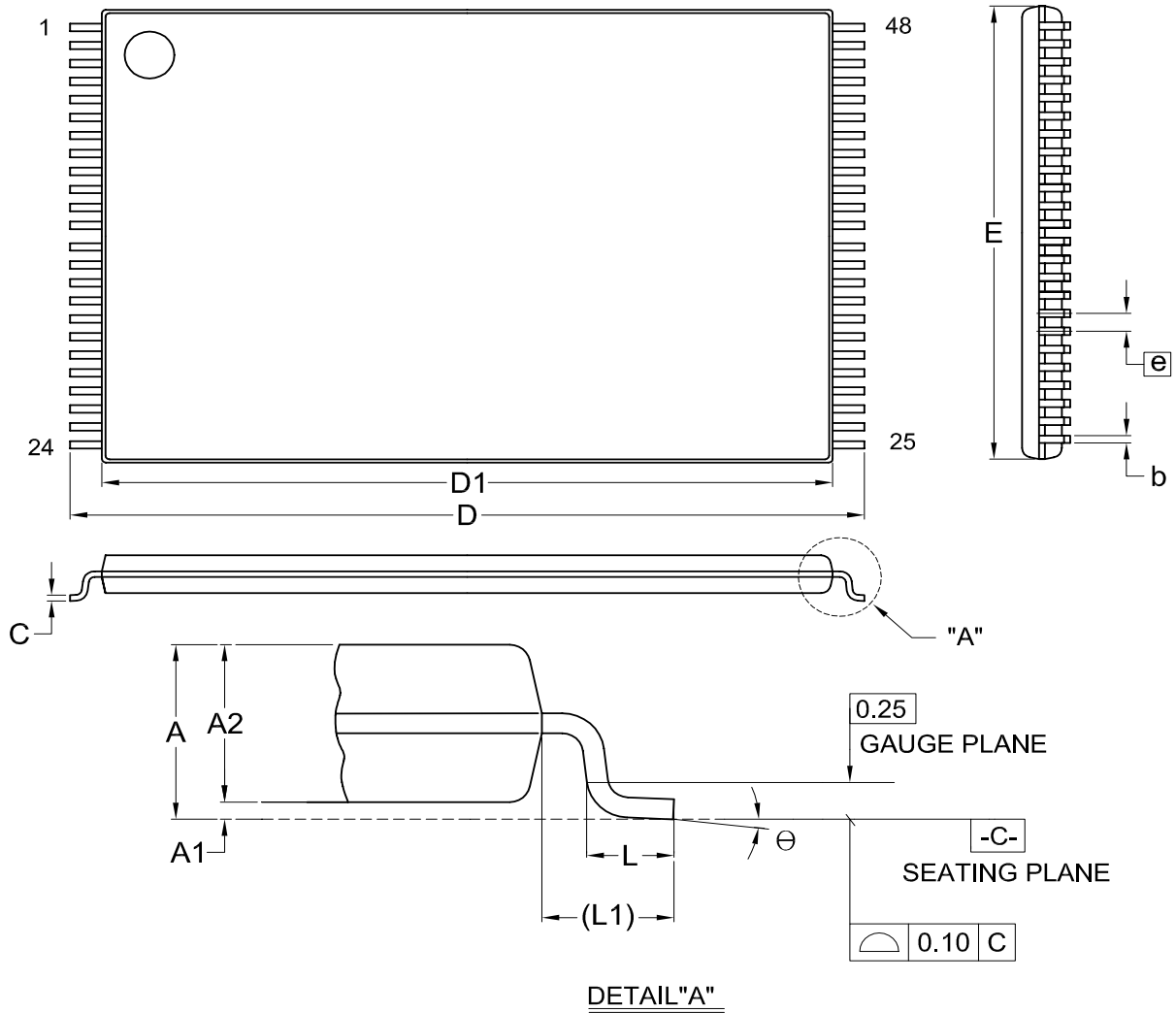
PACKAGE INFORMATION
Title: Package Outline for TSOP(I) 48L (12X20mm)NORMAL FORM

Dimensions (inch dimensions are derived from the original mm dimensions)

SYMBOL		A	A1	A2	b	C	D	D1	E	e	L	L1	θ
mm	Min.	---	0.05	0.95	0.17	0.10	19.80	18.30	11.90		0.50	0.70	0
	Nom.	---	0.10	1.00	0.20	0.13	20.00	18.40	12.00	0.50	0.60	0.80	5
	Max.	1.20	0.15	1.05	0.27	0.21	20.20	18.50	12.10		0.70	0.90	8
Inch	Min.	---	0.002	0.037	0.007	0.004	0.780	0.720	0.469		0.020	0.028	0
	Nom.	---	0.004	0.039	0.008	0.005	0.787	0.724	0.472	0.020	0.024	0.031	5
	Max.	0.047	0.006	0.041	0.011	0.008	0.795	0.728	0.476		0.028	0.035	8

DWG.NO.	REVISION	REFERENCE			ISSUE DATE
		JEDEC	EIAJ		
6110-1607	7	MO-142			12-01-'03

Title: Package Outline for CSP 48BALL(8X6X1.2MM,BALL PITCH 0.75MM,BALL DIAMETER 0.35MM)

TOP VIEW

BOTTOM VIEW

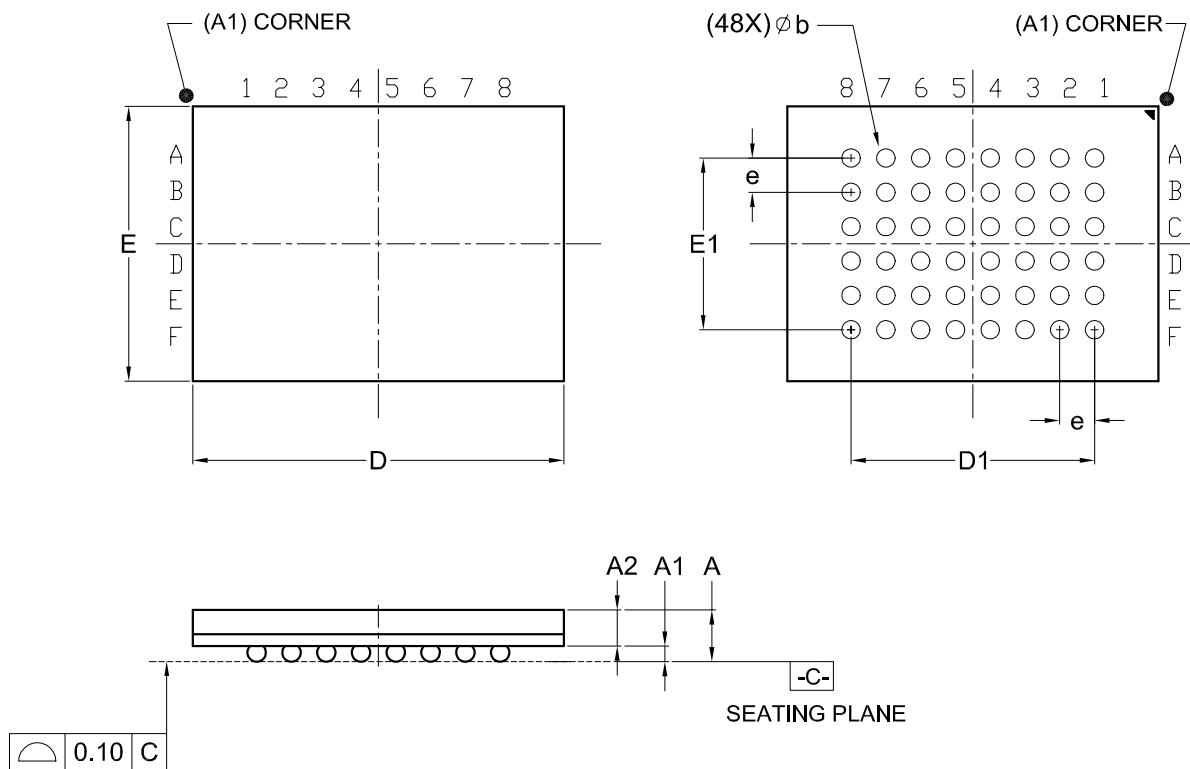

Dimensions (inch dimensions are derived from the original mm dimensions)

SYMBOL		A	A1	A2	b	D	D1	E	E1	e
mm	Min.	---	0.22	0.65	0.30	7.90		5.90		
	Nom.	---	0.27	---	0.35	8.00	5.25	6.00	3.75	0.75
	Max.	1.20	0.32	---	0.40	8.10		6.10		
Inch	Min.	---	0.009	0.026	0.012	0.311		0.232		
	Nom.	---	0.011	---	0.014	0.315	0.207	0.236	0.148	0.030
	Max.	0.047	0.013	---	0.016	0.319		0.240		

DWG.NO.	REVISION	REFERENCE			ISSUE DATE
		JEDEC	EIAJ		
6110-4208	4	MO-207			12-15-'05



REVISION HISTORY

Revision No.	Description	Page	Date
1.0	1. To modify "Advanced Information" to "Preliminary"	P1	NOV/27/2002
	1. To modify Package Information	P41,42	
1.1	1. To added address definition notes for Top/Bottom boot device of Protection Register Section	P18	MAY/05/2003
1.2	1. Removed "Preliminary" wording	P1	MAR/17/2004



MX28F160C3T/B

MACRONIX INTERNATIONAL Co., Ltd.

HEADQUARTERS:

TEL:+886-3-578-6688

FAX:+886-3-563-2888

EUROPE OFFICE:

TEL:+32-2-456-8020

FAX:+32-2-456-8021

JAPAN OFFICE:

TEL:+81-44-246-9100

FAX:+81-44-246-9105

SINGAPORE OFFICE:

TEL:+65-348-8385

FAX:+65-348-8096

TAIPEI OFFICE:

TEL:+886-2-2509-3300

FAX:+886-2-2509-2200

MACRONIX AMERICA, INC.

TEL:+1-408-453-8088

FAX:+1-408-453-8488

CHICAGO OFFICE:

TEL:+1-847-963-1900

FAX:+1-847-963-1909

[http : //www.macronix.com](http://www.macronix.com)