

## GHz PLL with I<sup>2</sup>C Bus and Four Chip Addresses

**MGP 3006X**

**Bipolar IC**

### Features

- 1-chip system for MPU-control (I<sup>2</sup>C Bus)
- 4 programmable chip addresses
- Short pull-in time for quick channel switch-over and optimized loop stability
- 2 high-current band switch outputs (20 mA)
- Software-compatible with SDA 3202 series
- Oxis III technology

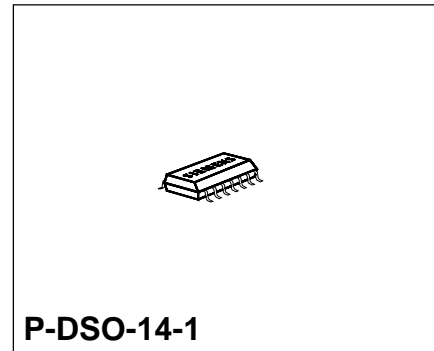

Type	Ordering Code	Package
MGP 3006X	Q67000-H5114	P-DSO-14-1 (SMD)
MGP 3006X	Q67006-H5114	P-DSO-14-1 Tape & Reel (SMD)

Combined with a VCO (tuner), the **MGP 3006X** device, with four hard-switched chip addresses, forms a digitally programmable phase-locked loop for use in television sets with PLL-frequency synthesis tuning. The PLL permits precise crystal-controlled setting of the frequency of the tuner oscillator between 16 and 1300 MHz in increments of 62.5 kHz, and, with a 2.4-GHz prescaler 1/2, in the TV-SAT band in increments of 125 kHz. The tuning process is controlled by a microprocessor via an I<sup>2</sup>C Bus. The I<sup>2</sup>C Bus noise immunity has been improved by a factor of 10 compared to the SDA 3202-2, and the new crystal oscillator generates a sinusoidal signal, suppressing the higher-order harmonics, which reduces the moiré noise considerably.

## Circuit Description

### Tuning Section

- UHF/VHF** The tuner signal is capacitively coupled at the UHF/VHF-input and subsequently amplified.
- REF** The reference input REF should be decoupled to ground using a capacitor of low series inductance. The signal passes through an asynchronous divider with a fixed ratio of  $P = 8$ , an adjustable divider with ratio  $N = 256$  through 32767, and is then compared in a digital frequency/phase detector to a reference frequency  $f_{REF} = 7.8125$  kHz.
- Q1, Q2** This frequency is derived from a balanced, low-impedance 4-MHz crystal oscillator (pin Q1, Q2) by dividing its output signal by  $Q = 512$ .  
The phase detector has two outputs UP and DOWN that drive the two current sources I+ and I- of a charge pump. If the negative edge of the divided VCO-signal appears prior to the negative edge of the reference signal, the I+ current source pulses for the duration of the phase difference. In the reverse case the I- current source pulses.
- PD, UD** If the two signals are in phase, the charge pump output (PD) goes into the high-impedance state (PLL is locked). An active low-pass filter integrates the current pulses to generate the tuning voltage for the VCO (internal amplifier, external output transistor at UD and external RC-circuitry). The charge pump output is also switched into the high-impedance state when the control bit T0 = 1. Here it should be noted, however, that the tuning voltage can alter over a long period in the high-impedance state as a result of self-discharge in the peripheral circuitry. UD may be switched off by the control bit OS to allow external adjustments.  
By means of a control bit 5I the pump current can be switched between two values by software. This programmability permits alteration of the control response of the PLL in the locked-in state. In this way different VCO-gains in the different TV-bands can be compensated, for example.
- P1, P2** The software-switched outputs P1, P2 can be used for direct band selection (20 mA current output).
- P7** P7 is a general-purpose open-collector output. The test bit T1 = 1 switches the test signal Cy (divided input signal) to P7.
- CAU** Four different chip addresses can be set by appropriate connection of pin CAU.

## I<sup>2</sup>C Bus Interface

Data are exchanged between the processor and the PLL on the I<sup>2</sup>C Bus.

**SCL, SDA** The clock is generated by the processor (input SCL), while pin SDA works as an input or output depending on the direction of the data (open collector; external pull-up resistor). Both inputs have hysteresis and a low-pass characteristic, which enhances the noise immunity of the I<sup>2</sup>C Bus.

The data from the processor pass through an I<sup>2</sup>C Bus control. Depending on their function the data are subsequently stored in registers. If the bus is free, both lines will be in the marking state (SDA, SCL are high). Each telegram begins with the start condition and ends with the stop condition. Start condition: SDA goes low, while SCL remains high. Stop condition: SDA goes high while SCL remains high. All further information transfer takes place during SCL = low, and the data is forwarded to the control logic on the positive clock edge.

The table “bit allocation” should be referred to in the following paragraph.

All telegrams are transmitted byte-by-byte, followed by a ninth clock pulse, during which the control logic returns the SDA-line to low (acknowledge condition). The first byte is comprised of seven address bits. These are used by the processor to select the PLL from several peripheral components (chip select). The eighth bit is always low.

In the data portion of the telegram the first bit of the first or third data byte determines whether a divider ratio or control information is to follow. In each case the second byte of the same data type or a stop condition has to follow the first byte.

**V<sub>s</sub>, GND** When the supply voltage is applied a power-on reset circuit prevents the PLL from setting the SDA-line to low, which would block the bus.

## Circuit Description (cont'd)

### Bit Allocation

	MSB	A = Acknowledge							
Address byte	1	1	0	0	0	MA1	MA0	0	A
Prog. divider Byte 1	0	n14	n13	n12	n11	n10	n9	n8	A
Prog. divider Byte 2	n7	n6	n5	n4	n3	n2	n1	n0	A
Control info. Byte 1	1	5I	T1	T0	1	1	1	OS	A
Control info. Byte 2	P7	X	X	X	X	P2	P1	X	A

### Divider Ratio

$$N = 16384 \times n_{14} + 8192 \times n_{13} + 4096 \times n_{12} + 2048 \times n_{11} + 1024 \times n_{10} + 512 \times n_9 + 256 \times n_8 + 128 \times n_7 + 64 \times n_6 + 32 \times n_5 + 16 \times n_4 + 8 \times n_3 + 4 \times n_2 + 2 \times n_1 + n_0$$

### Band Selection

P1, P2, P7 = 1                      Open-collector output is active.

### Pump Current Programming

5I = 1                                  High current

### UD Disable

OS = 1                                  UD is disabled.

### Test Mode

T1, T0 = 0, 0                      Normal operation  
 T1 = 1                                  P7 = carry Cy of programmable divider  
 T0 = 1                                  Tristate: charge pump output PD is in high-impedance state.

## Chip Address Switching

MA1	MA0	Voltage at CAU
0	0	(0 ... 0.1) $V_S$
0	1	open-circuit
1	0	(0.4 ... 0.6) $V_S$
1	1	(0.9 ... 1) $V_S$

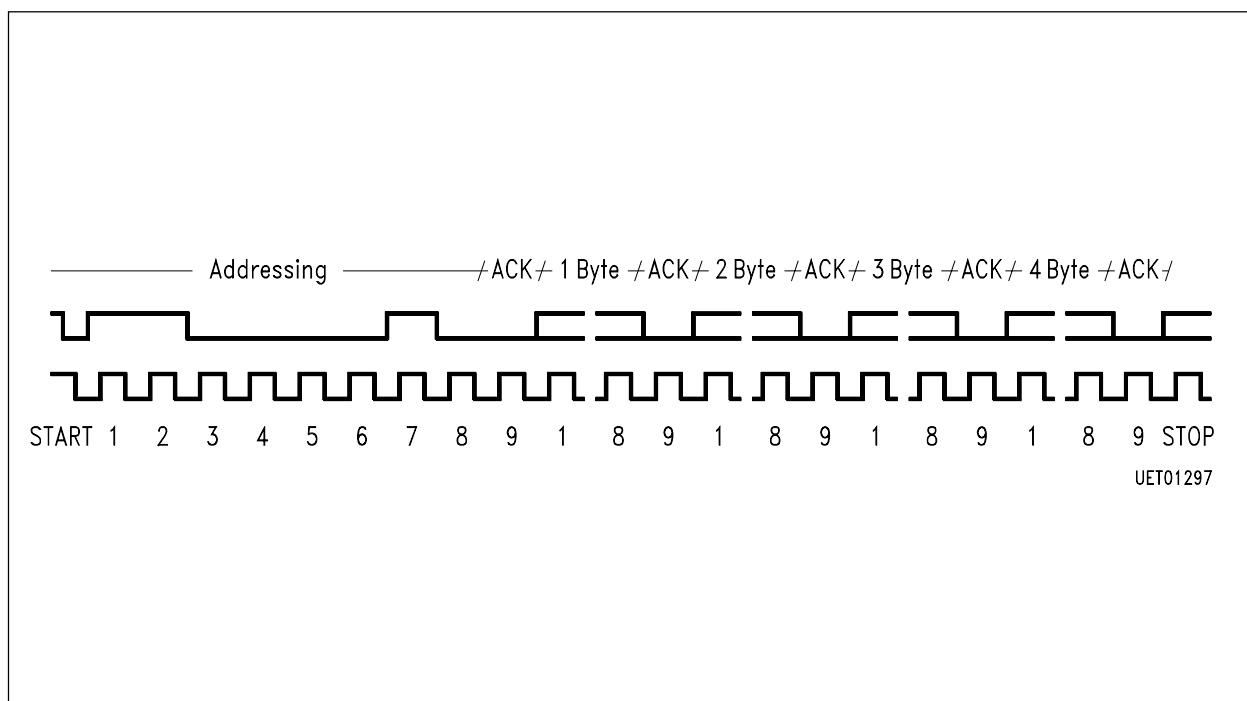

## Telegram Examples

Start-Addr-DR1-DR2-CW1-CW2-Stop  
 Start-Addr-CW1-CW2-DR1-DR2-Stop  
 Start-Addr-DR1-DR2-CW1-Stop  
 Start-Addr-CW1-CW2-DR1-Stop  
 Start-Addr-DR1-DR2-Stop  
 Start-Addr-CW1-CW2-Stop  
 Start-Addr-DR1-Stop  
 Start-Addr-CW1-Stop

Start = start condition  
 Addr = address  
 DR1 = divider ratio 1st byte  
 DR2 = divider ratio 2nd byte  
 CW1 = control word 1st Byte  
 CW2 = control word 2nd Byte  
 Stop = stop condition

Pin Configuration  
(top view)

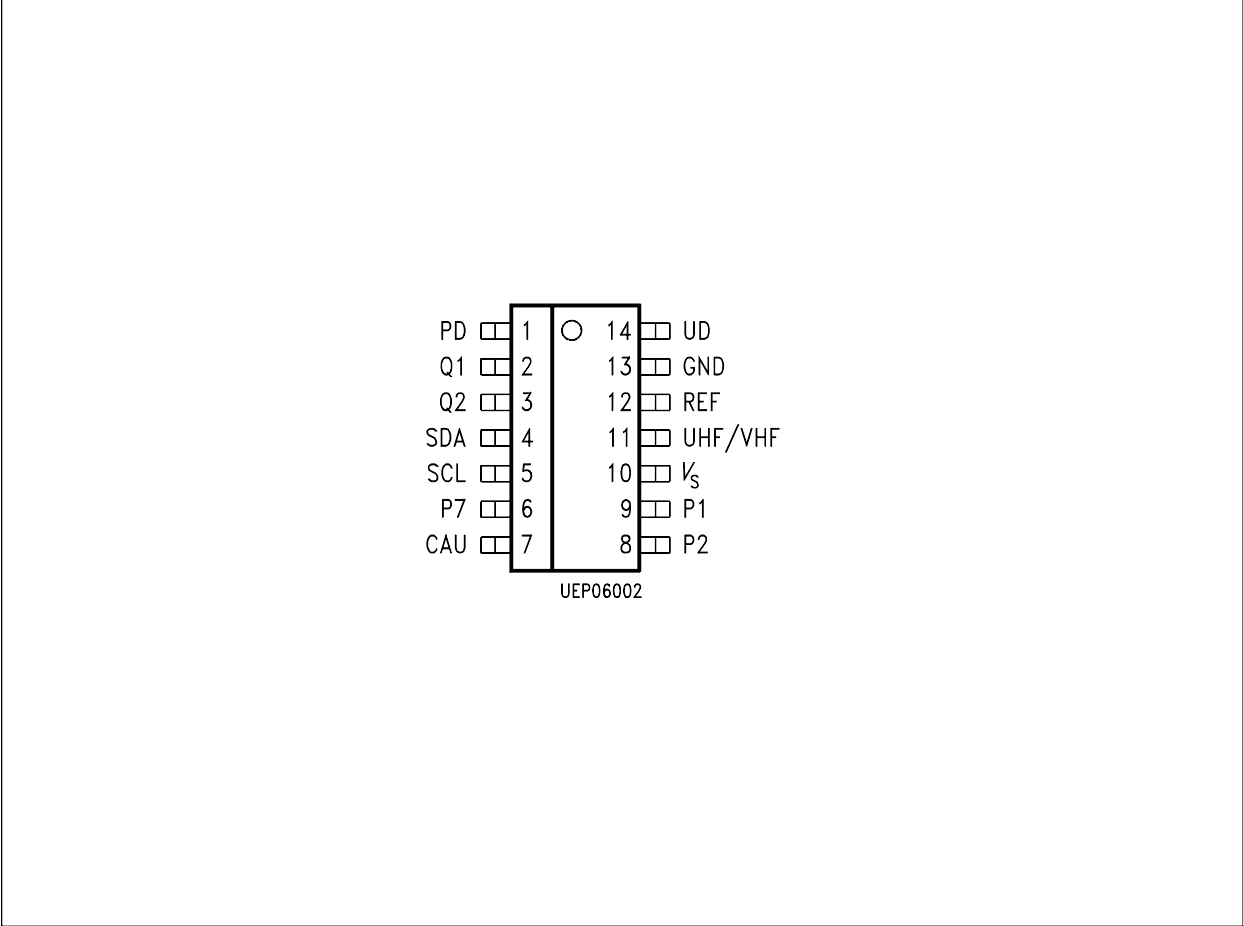

---

**Pin Definitions and Functions**

<b>Pin No.</b>	<b>Symbol</b>	<b>Function</b>
1	PD	Input active filter/charge pump output
2	Q1	Quartz crystal
3	Q2	Quartz crystal
4	SDA	Data input/output for I <sup>2</sup> C Bus
5	SCL	Clock input for I <sup>2</sup> C Bus
6	P7	Port output (open collector)
7	CAU	Address switch input
8	P2	Port output (open collector)
9	P1	Port output (open collector)
10	V <sub>s</sub>	Supply voltage
11	UHF/VHF	Signal input
12	REF	Amplifier reference input
13	GND	Ground
14	UD	Output active filter

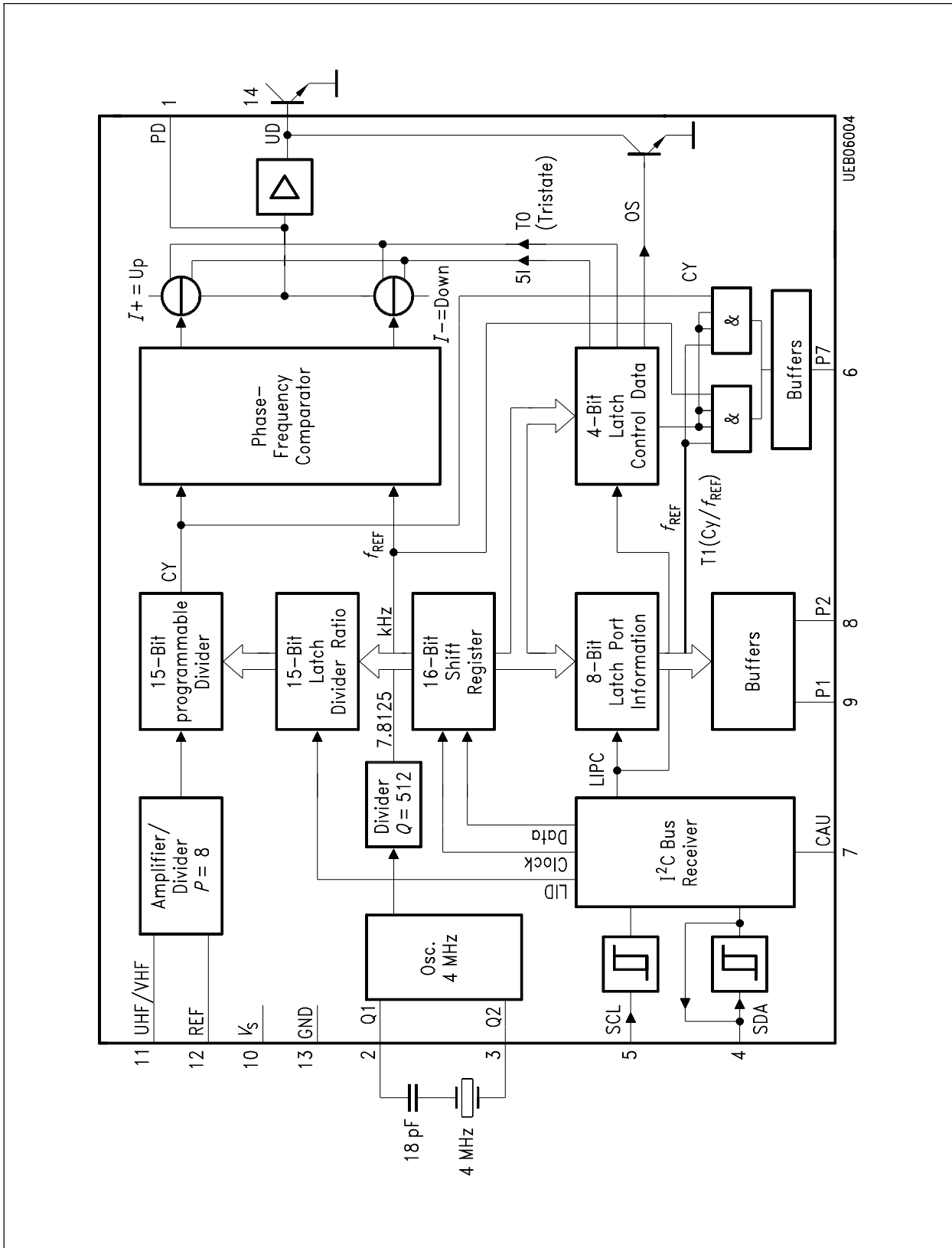

Block Diagram

## Absolute Maximum Ratings

$T_A = -20$  to  $80$  °C

Parameter	Symbol	Limit Values		Unit	Remarks
		min.	max.		
Supply voltage	$V_S$	-0.3	6	V	
Output PD	$V_1$	-0.3	$V_S$	V	
Crystal oscillator pins Q1, Q2	$V_2$	-0.3	$V_S$	V	
Bus input/output SDA	$V_4$	-0.3	6	V	
Bus input SCL	$V_5$	-0.3	6	V	
Port outputs P1, P2, P7	$V_6$	-0.3	16	V	
Chip address switch CAU	$V_7$	-0.3	$V_S$	V	
Signal input UHF/VHF	$V_{11}$	-0.3	0.3	V	for $V_S = 0$ V
Reference input REF	$V_{12}$	-0.3	0.3	V	for $V_S = 0$ V
Output active filter UD	$V_{14}$	-0.3	$V_S$	V	
Bus output SDA	$I_{4L}$	-1	5	mA	open collector
Port outputs P7	$I_{6L}$	-1	7	mA	open collector
Port outputs P1, P2	$I_{8L}$	-1	20	mA	open collector
Total port output current	$\Sigma I_L$		25	mA	
Junction temperature	$T_j$		125	°C	
Storage temperature	$T_{stg}$	-40	125	°C	
Thermal resistance (junction to ambient)	$R_{th JA}$		125	K/W	

## Absolute Maximum Ratings (cont'd)

$T_A = -20$  to  $80$  °C

Parameter	Symbol	Limit Values		Unit	Remarks
		min.	max.		

## Operating Range

Supply voltage	$V_S$	4.5	5.5	V	
Ambient temperature	$T_A$	-20	80	°C	
Input frequency	$f_{11}$	16	1300	MHz	(at 25 °C)
Crystal frequency	$f_2$		4	MHz	
Programmable divider factor	$N$	256	32767		

## AC/DC Characteristics

$T_A = -20$  to  $80$  °C;  $V_S = 4.5$  to  $5.5$  V

Parameter	Symbol	Limit Values			Unit	Test Condition	Test Circuit
		min.	typ.	max.			
Supply current	$I_S$		37	55	mA	$V_S = 5$ V	1
Crystal oscillator frequency	$f_2$	3.99975	4.000	4.00025	MHz	series capacitance 18 pF, $f_Q = 4$ MHz	1
Oscillator amplitude (voltage across crystal)			2.6 <sup>1)</sup>		V <sub>pp</sub>		
Margin from 1st (fundamental) to 2nd and 3rd harmonics			20 <sup>1)</sup>		dB		

## Signal Input UHF/VHF

Sensitivity	$a_{11}$	-27/10		3/315	dBm <sup>2)</sup>	$f_{11} = 70 \dots 500$ MHz	2
	$a_{11}$	-27/10		3/315	dBm <sup>2)</sup>	$f_{11} = 1000$ MHz	2
	$a_{11}$	-20/22		3/315	dBm <sup>2)</sup>	$f_{11} = 1100$ MHz	2

Notes see page 11.

**AC/DC Characteristics (cont'd)** $T_A = -20$  to  $80$  °C;  $V_S = 4.5$  to  $5.5$  V

Parameter	Symbol	Limit Values			Unit	Test Condition	Test Circuit
		min.	typ.	max.			

**Port Output P7 (switch with open collector)<sup>3)</sup>**

H-input current	$I_{6H}$			10	$\mu\text{A}$	$V_{6H} = 13.5$ V	4
L-output voltage	$V_{6L}$			0.5	V	$I_{6L} = 1.7$ mA	4

**Port Outputs P1, P2 (switch with open collector)<sup>3)</sup>**

H-input current	$I_{8H}$			10	$\mu\text{A}$	$V_{8H} = 13.5$ V	3
L-output voltage	$V_{8L}$			0.5	V	$I_{8L} = 20$ mA	3

**Phase-Detector Output PD ( $V_S = 5$  V)**

Pump current	$I_{1H}$	$\pm 90$	$\pm 220$	$\pm 300$	$\mu\text{A}$	5I = high; $V_1 = 2$ V	5
Pump current	$I_{1H}$	$\pm 22$	$\pm 50$	$\pm 75$	$\mu\text{A}$	5I = low; $V_1 = 2$ V	5
Tristate current	$I_{1Z}$	-5	0	5	nA	T1 = 1; $V_1 = 2$ V	5
Output voltage	$V_{1L}$	1.0		2.5	V	locked	5

**Active Filter Output UD (Test mode T0 = 1; PD = tristate)**

Output current	$-I_{14}$	500			$\mu\text{A}$	$V_{14} = 0.8$ V; $I_{1H} = 90$ $\mu\text{A}$	5
Output voltage	$V_{14}$			100	mV	$V_{1L} = 0$ V	5
Output voltage	$V_{14}$			500	mV	OS = 1;	5

**Chip Address Switch CAU**

Input current	$I_{7H}$			50	$\mu\text{A}$	$V_{7H} = 5$ V	7
Input current	$-I_{7H}$			50	$\mu\text{A}$	$V_{7H} = 5$ V	7

1) Design note only: no 100 % final inspection.

2) mVrms into  $50$   $\Omega$ .

3) The sum of the currents in ports P1, P2, P7 may not exceed 25 mA.

**AC/DC Characteristics (cont'd)** $T_A = -20$  to  $80$  °C;  $V_S = 4.5$  to  $5.5$  V; refer to test circuit 6

Parameter	Symbol	Limit Values			Unit	Test Condition
		min.	typ.	max.		

**Bus Inputs SCL, SDA**

H-input voltage	$V_{4IH}$	3		5.5	V	
L-input voltage	$V_{4IL}$			1.5	V	
H-input current	$I_{4IH}$			10	$\mu$ A	$V_{4IH} = V_S$
L-input current	$-I_{4IL}$			20	$\mu$ A	$V_{4IL} = 0$ V

**Bus Output SDA (open collector)**

H-output current	$I_{4OH}$			10	$\mu$ A	$V_{4OH} = 5.5$ V
L-output voltage	$V_{4OL}$			0.4	V	$I_{4OL} = 3$ mA

**Edges SCL, SDA**

Rise time	$t_R$			1	$\mu$ s	
Fall time	$t_F$			0.3	$\mu$ s	

**Shift Clock SCL**

Frequency	$f_S$	0		100	kHz	
H-pulse width	$t_{5H}$	4			$\mu$ s	
L-pulse width	$t_{5L}$	4.7			$\mu$ s	

**Start**

Set-up time	$t_{SUSTA}$	4.7			$\mu$ s	
Hold time	$t_{HDSTA}$	4			$\mu$ s	

**Stop**

Set-up time	$t_{SUSTO}$	4.7			$\mu$ s	
Bus free	$t_{BUF}$	4.7			$\mu$ s	

**AC/DC Characteristics (cont'd)**

$T_A = -20$  to  $80$  °C;  $V_S = 4.5$  to  $5.5$  V; refer to test circuit 6

Parameter	Symbol	Limit Values			Unit	Test Condition
		min.	typ.	max.		

**Data Transfer**

Set-up time	$t_{SUDAT}$	0.25			$\mu$ s	
Hold time	$t_{HDDAT}$	0			$\mu$ s	
Input hysteresis SCL, SDA <sup>1)</sup>			300		mV	
Low-pass cutoff frequency SCL, SDA <sup>1)</sup>			500		kHz	

1) Design note only: no 100 % final inspection.

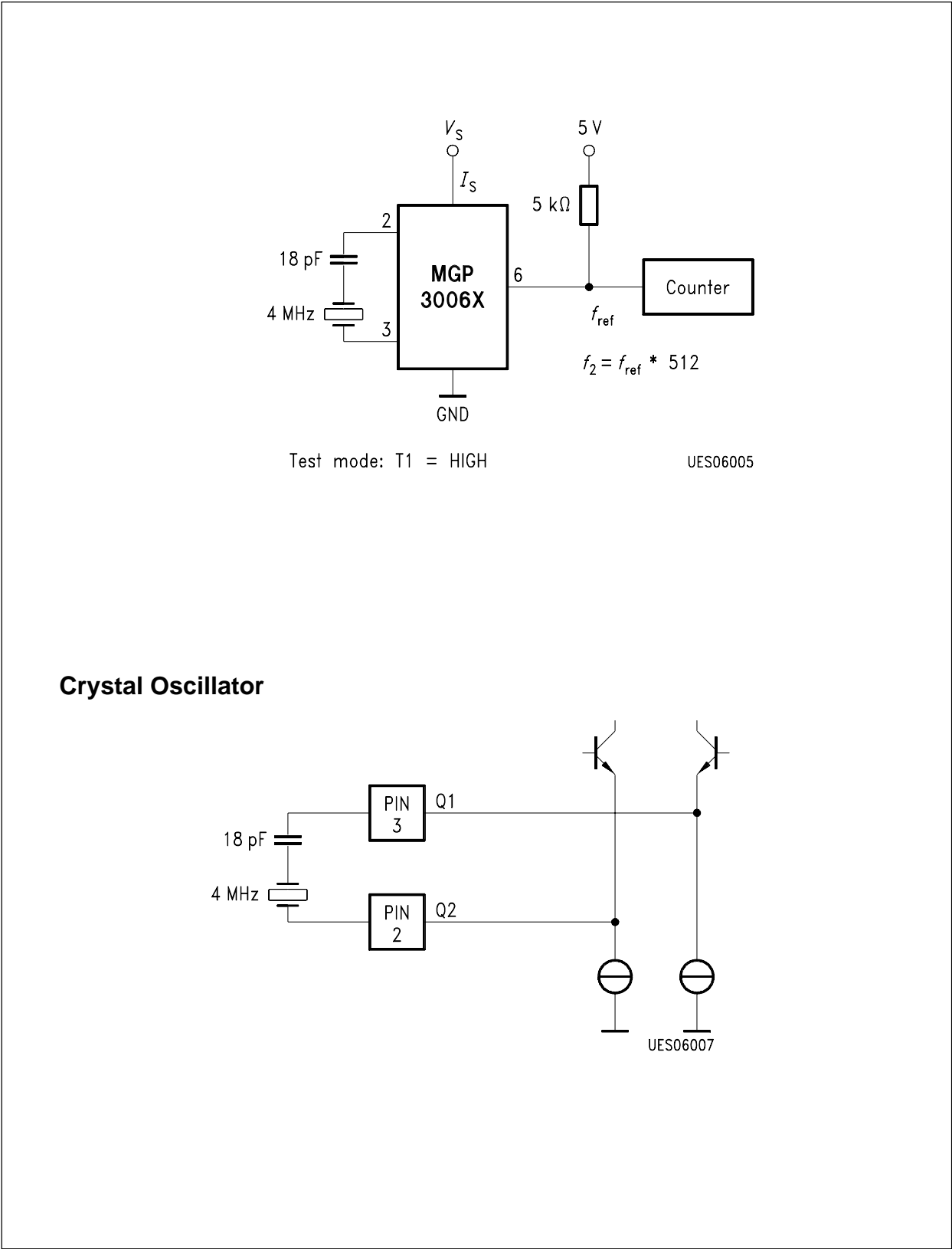

**Crystal Oscillator**

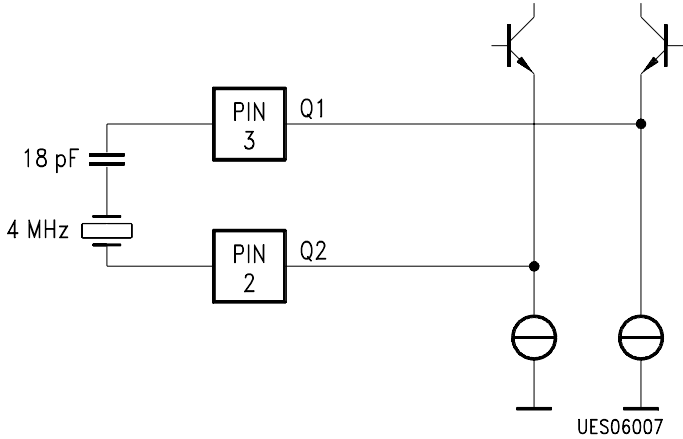

**Test Circuit 1**

**Calibration of Signal Generator**

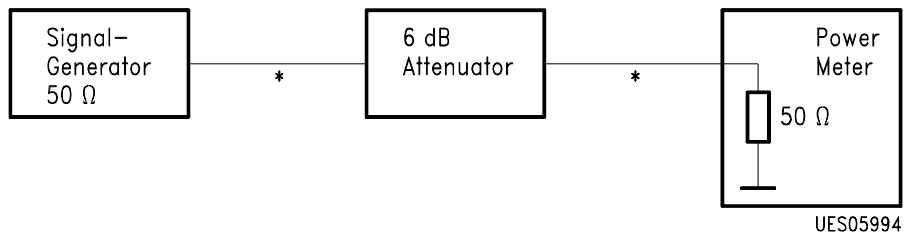

**Measurement of Input Sensitivity**

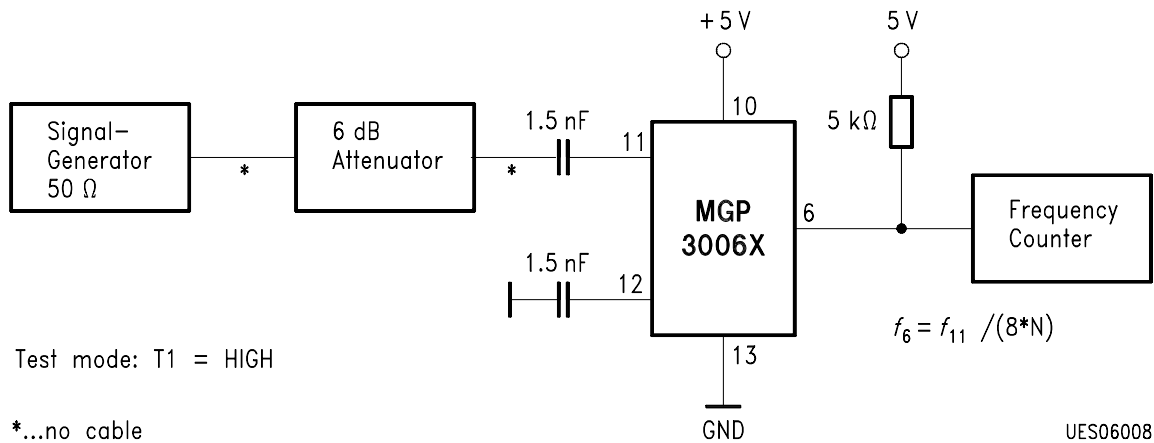

**Test Circuit 2**

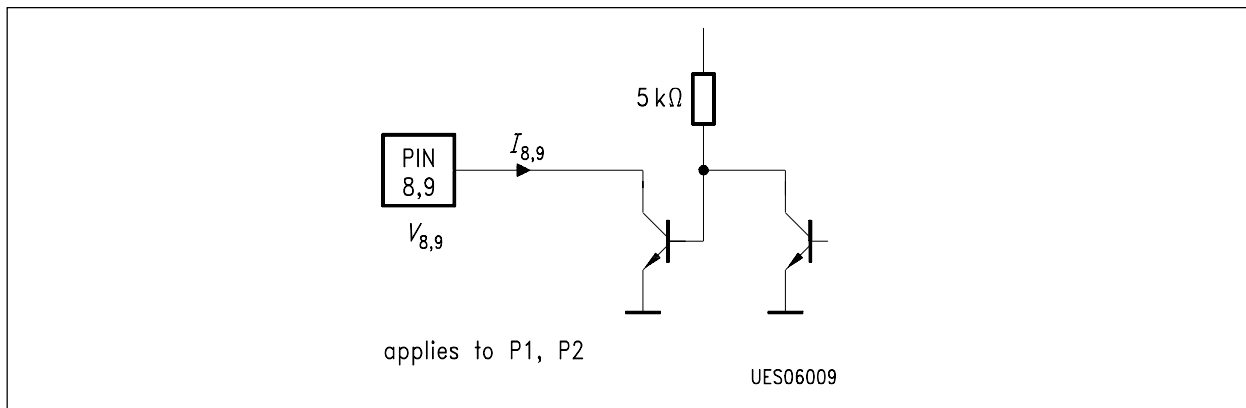

Test Circuit 3

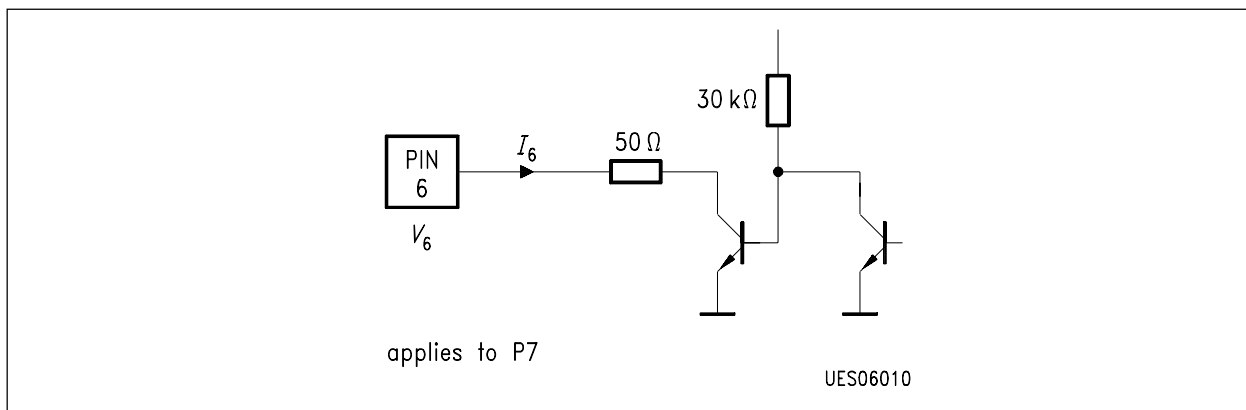

Test Circuit 4

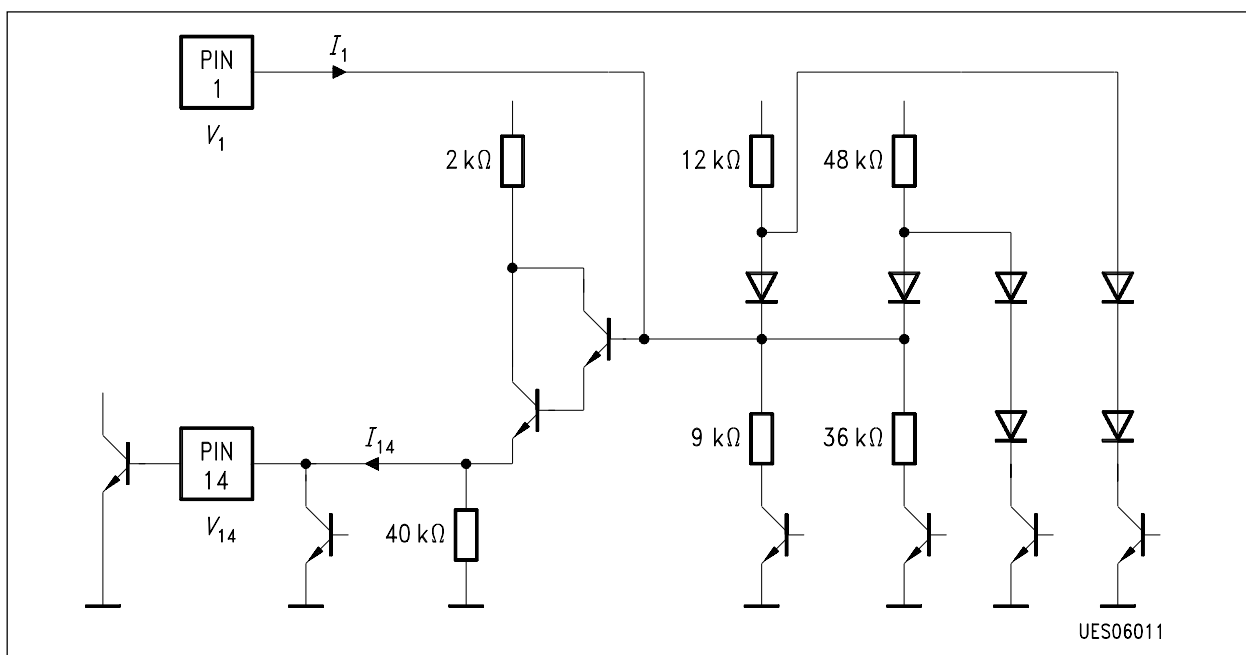

Test Circuit 5

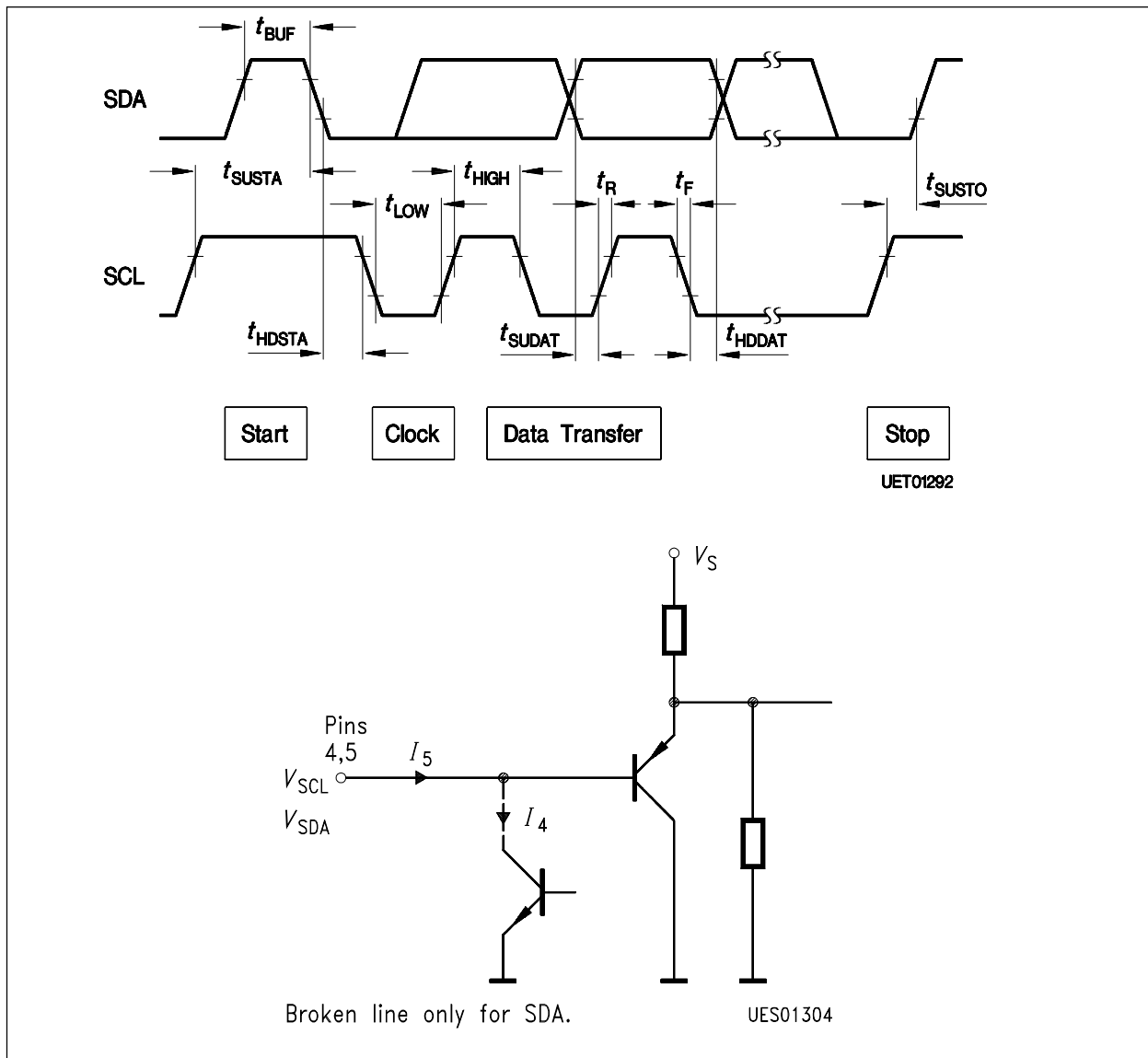

**Test Circuit 6**

**I<sup>2</sup>C Bus Timing Diagram**

Set-up time (start)	$t_{SUSTA}$
Hold time (start)	$t_{HDSTA}$
H-pulse width (clock)	$t_{HIGH}$
L-pulse width (clock)	$t_{LOW}$
Set-up time (data transfer)	$t_{SUDAT}$
Hold time (data transfer)	$t_{HDDAT}$
Set-up time (stop)	$t_{SUSTO}$
Bus free time	$t_{BUF}$
Fall time	$t_F$
Rise time	$t_R$

All times related to 10 % and 90 % values.

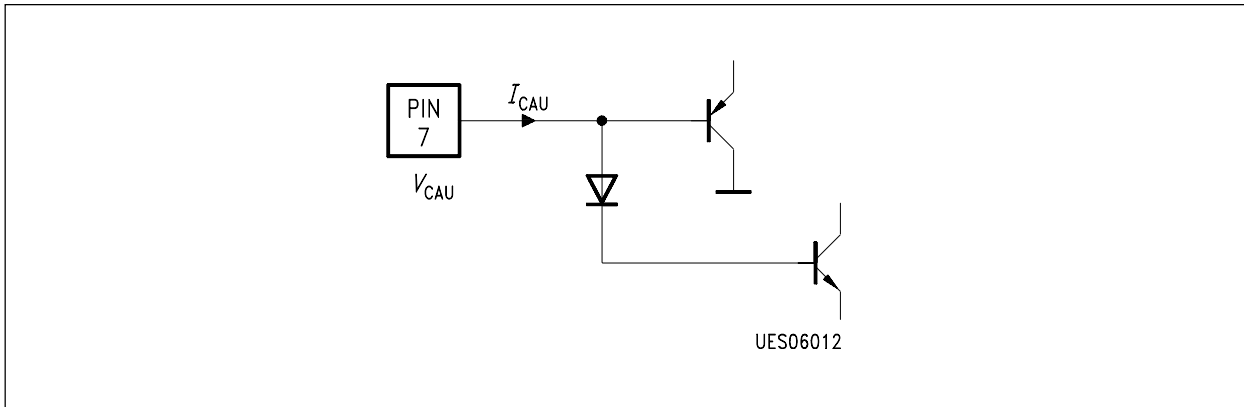

**Test Circuit 7**

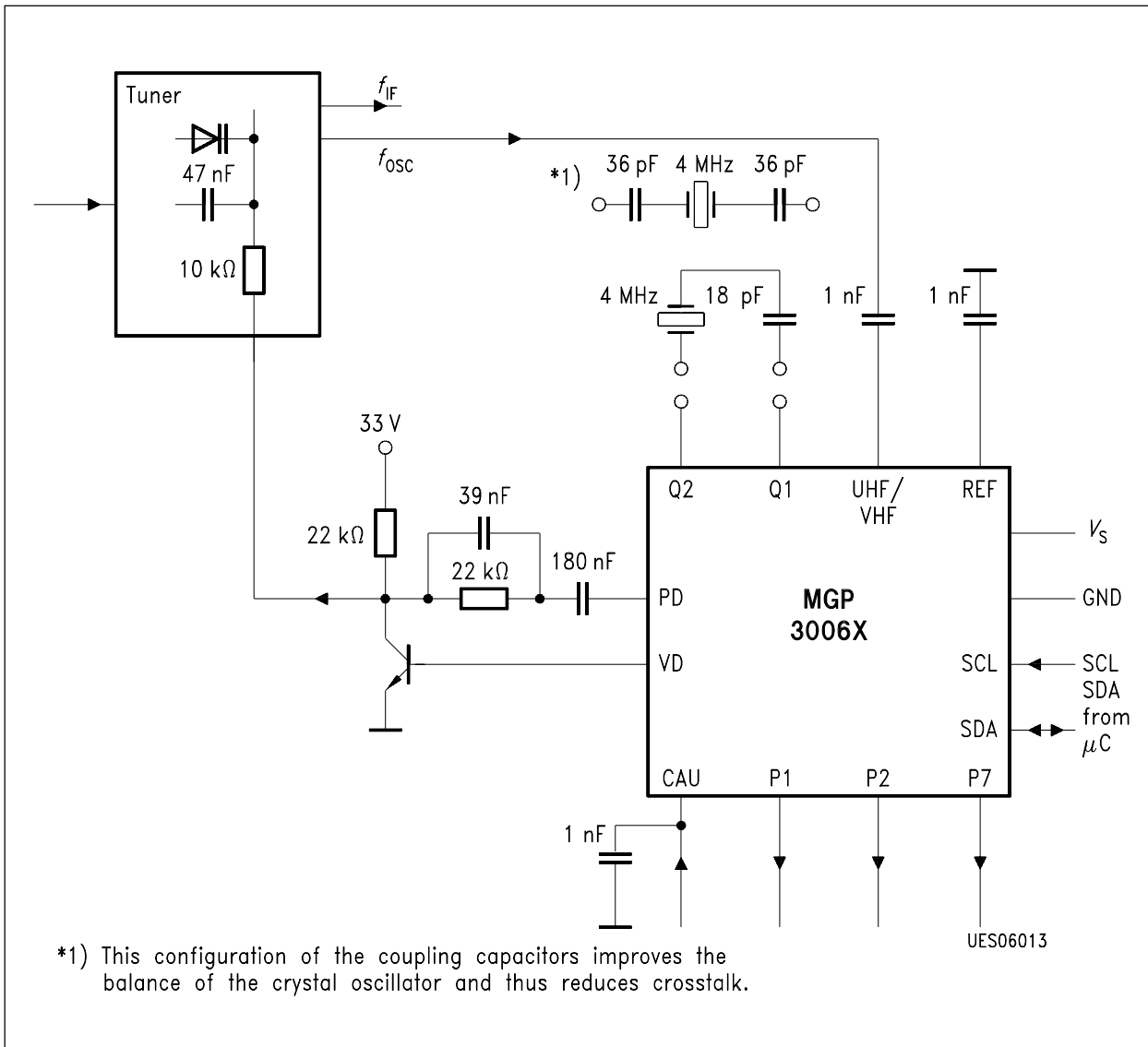

**Application Circuit**

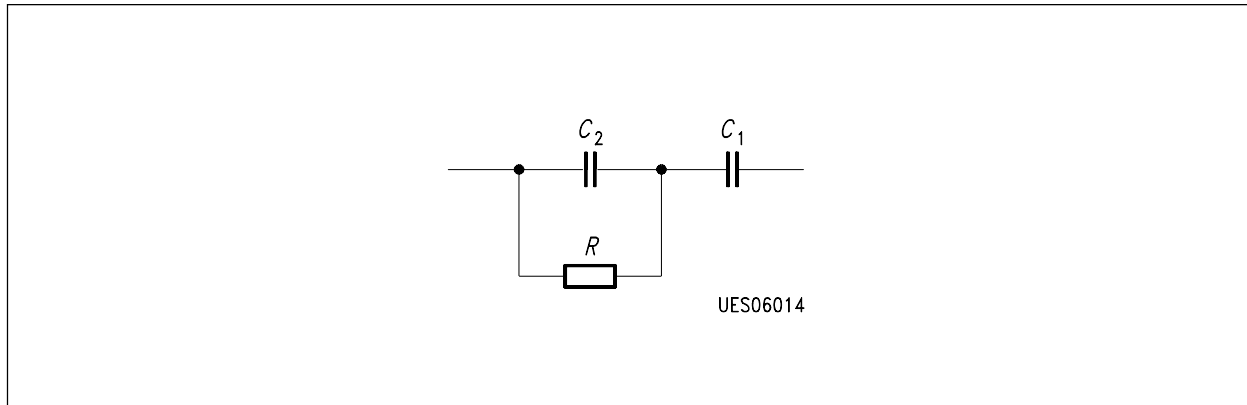

## Loop Filter

### Loop Filter Calculation

Loop bandwidth:  $\omega_R = \sqrt{[(I_P \times K_{VCO}) / (C_1 \times P \times N)]}$

Attenuation:  $a = 0.5 \times \omega_R \times R \times C_1$

$P$  = prescaler division ratio

$N$  = programmable division ratio

$I_P$  = charge pump current

$K_{VCO}$  = tuner slope

$R, C_1$  = loop filter

Example for channel 47:

$P = 8, N = 11520, I_P = 50 \mu\text{A}, K_{VCO} = 18.7 \text{ MHz/V}, R = 22 \text{ k}\Omega, C_1 = 180 \text{ nF},$   
 $\omega_R = 237 \text{ Hz}, f_R = 38 \text{ Hz}, a = 0.47$

**Note:** The high-impedance port outputs and CAU can be decoupled from external noise with a capacitor of 1 nF.

It is important to keep to the I<sup>2</sup>C Bus specification concerning maximum capacitance and impedance.

Diagrams

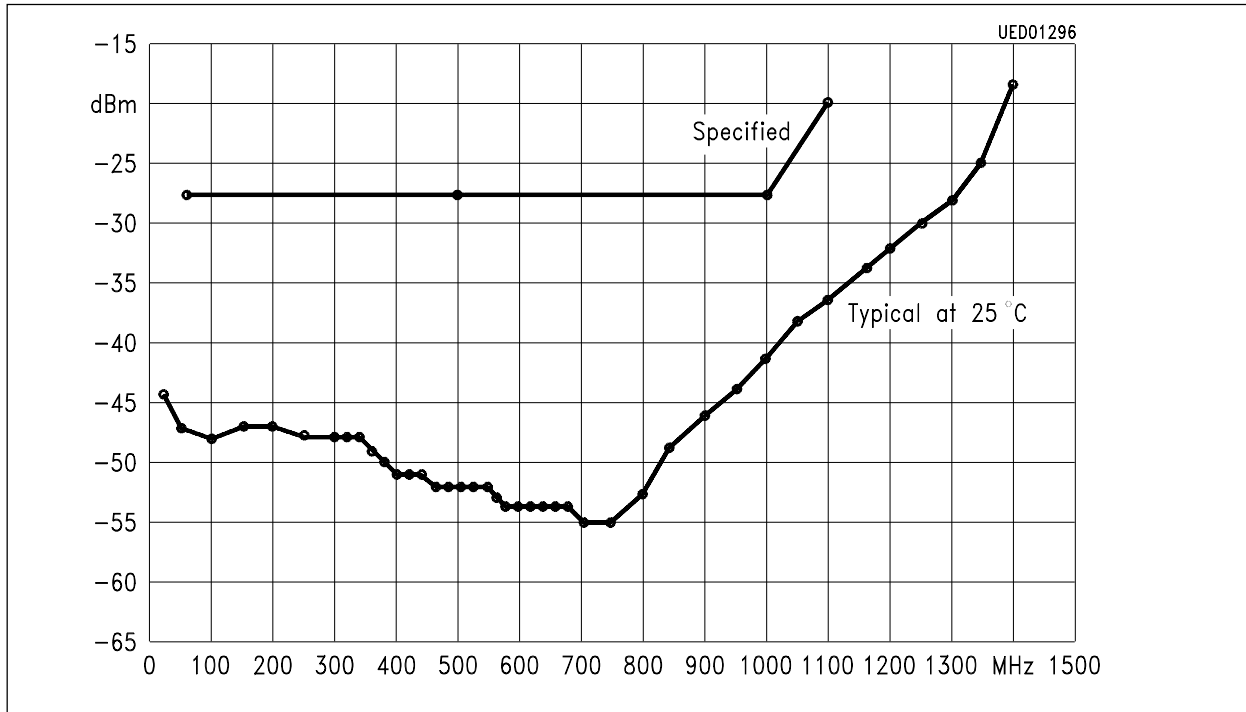

Sensitivity at UHF/VHF-Input

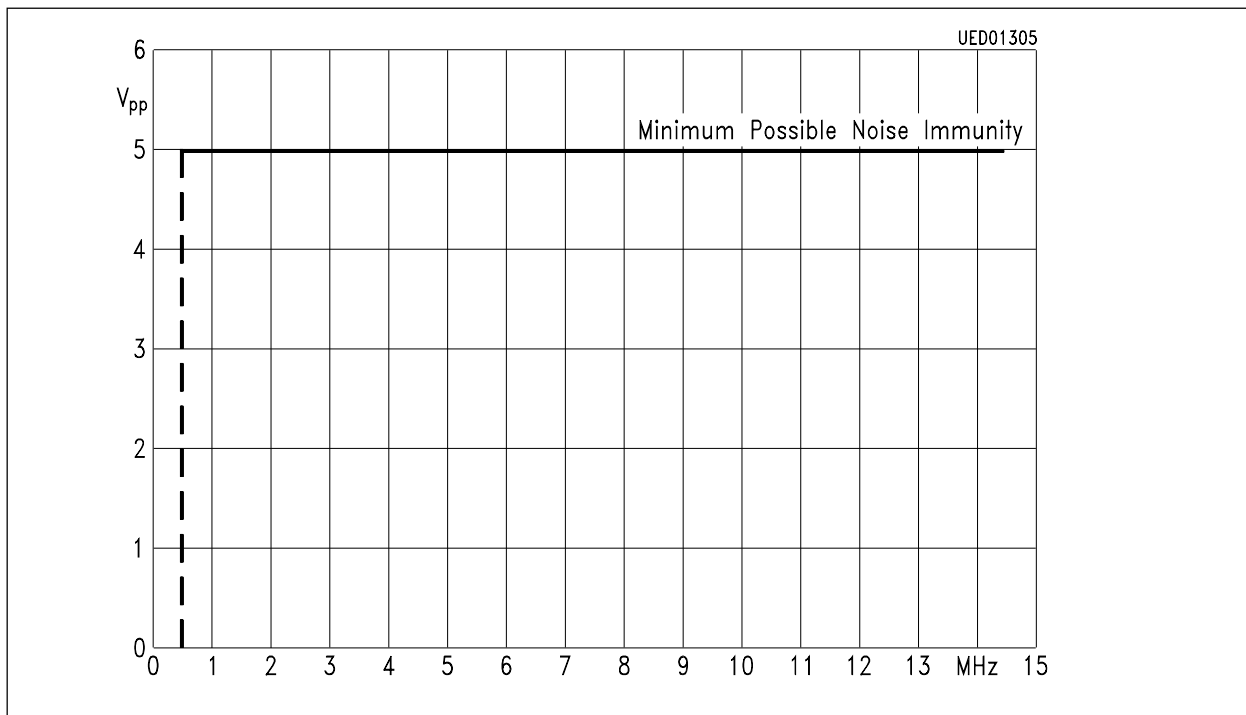

I<sup>2</sup>C Bus Noise Immunity

Sinusoidal noise pulses are applied via a coupling capacitance of 33 pF to the SCL- and SDA-inputs.

**Plastic Package, P-DSO-14-1 (SMD)**  
 (Plastic Dual Small Outline)

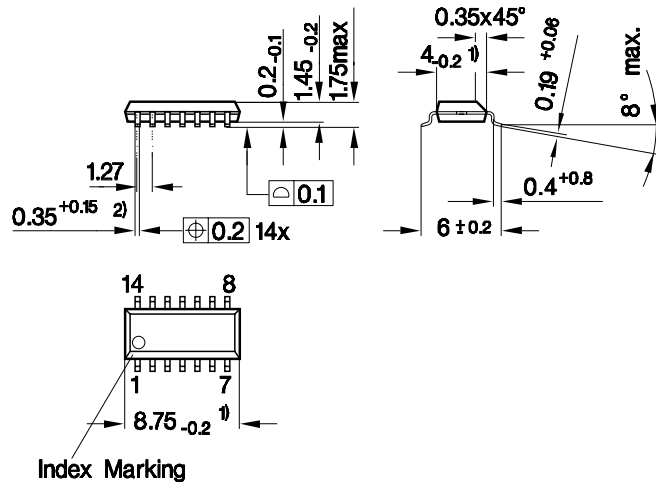

- 1) Does not include plastic or metal protrusion of 0.15 max. per side
- 2) Does not include dambar protrusion of 0.05 max. per side

GPS05093

**Sorts of Packing**

Package outlines for tubes, trays etc. are contained in our Data Book "Package Information"

SMD = Surface Mounted Device

Dimensions in mm