

FEATURES

Compatible with Microsoft PC 97 Logo Requirements
 Supports Applications Written for Windows[®] 95,
 Windows 3.1, Windows NT, SoundBlaster[®] Pro,
 AdLib[®]/OPL3[®]

Stereo Audio 16-Bit $\Sigma\Delta$ Codec
 MPC Level-3 Mixer
 ISA Plug and Play Compatible
 16-Bit Address Decode
 Dual Type F FIFO DMA Support
 MPU-401 Compatible MIDI Port
 Supports Wavetable Synthesizers

Integrated Enhanced Digital Game Port
 Integrated OPL3 Compatible Music Synthesizer
 Software & Hardware Volume Control
 Full-Duplex Capture and Playback Operation at
 Different Sample Rates
 1 Hz Resolution Programmable Sample Rates from
 5.7 kHz to 55.2 kHz
 ACPI Power Management Modes
 Operation from +5 V Supply
 Built-In 24 mA Bus Drivers
 100-Lead PQFP Package

PRODUCT OVERVIEW

The AD1817A SoundPort[®] Controller is a single chip Plug and Play multimedia audio subsystem for concurrently processing

FUNCTIONAL BLOCK DIAGRAM

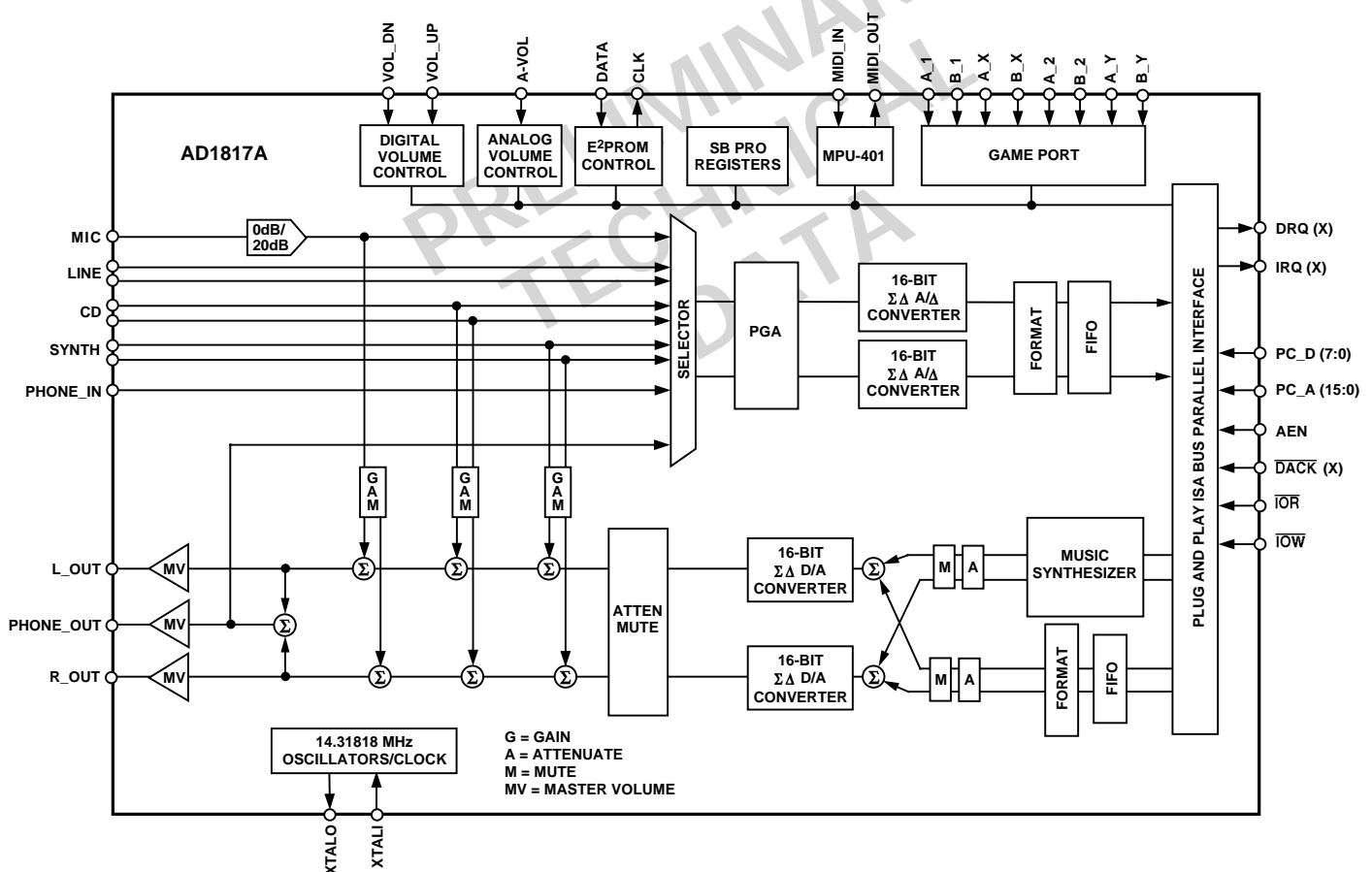

*SoundPort is a registered trademark of Analog Devices, Inc.
 All trademarks are the property of their respective holders.

REV. 0

Information furnished by Analog Devices is believed to be accurate and reliable. However, no responsibility is assumed by Analog Devices for its use, nor for any infringements of patents or other rights of third parties which may result from its use. No license is granted by implication or otherwise under any patent or patent rights of Analog Devices.

One Technology Way, P.O. Box 9106, Norwood, MA 02062-9106, U.S.A.
 Tel: 617/329-4700 World Wide Web Site: <http://www.analog.com>
 Fax: 617/326-8703 © Analog Devices, Inc., 1997

AD1817A

multiple digital streams of 16-bit stereo audio in personal computers. The AD1817A maintains full legacy compatibility with applications written for SoundBlaster Pro and AdLib, while servicing Microsoft PC 97 application requirements. The AD1817A includes an internal OPL3 compatible music synthesizer, an MPU-401 UART and a joystick interface with a

built-in timer. The AD1817A on-chip Plug and Play routine provides configuration services for all integrated logical devices. Using an external E²PROM allows the AD1817A to decode up to three additional external user-defined logical devices such as modem and CD-ROM.

TABLE OF CONTENTS

FEATURES	1	Figures	
PRODUCT OVERVIEW	1	Functional Block Diagram	1
SPECIFICATIONS	3	Figure 1. PIO Read Cycle	6
PIN CONFIGURATION	9	Figure 2. PIO Write Cycle	6
PIN FUNCTION DESCRIPTION	10	Figure 3. DMA Read Cycle	7
HOST INTERFACE	14	Figure 4. DMA Write Cycle	7
REFERENCES	15	Figure 5. Codec Transfers	7
ISA INTERFACE	16	Figure 6. Reset Pulse Width	7
AD1817A Chip Registers	16	Figure 7. Codec Transfers	22
AD1817A Plug and Play Device Configuration Registers ..	16	Figure 8. Typical Application Circuit	42
Sound System Direct Registers	18	Figure 9. AD1817A Frequency Response Plots	43
Sound System Indirect Registers	24	Tables	
SB Pro; Adlib Registers	33	Table I. Chip Register Diagram	16
MIDI and MPU-401 Registers	33	Table II. Logical Devices and Compatible Plug and Play Device Drivers	17
Game Port Register	34	Table III. Logical Device Configuration	17
APPENDIX A.		Table IV. Sound System Direct Registers	18
PLUG AND PLAY INTERNAL ROM	35	Table V. Codec Transfers	22
PLUG AND PLAY KEY and "ALTERNATE KEY" SEQUENCES	36	Table VI. Indirect Register Map and Reset/Default States ..	25
USING AN EEPROM WITH THE AD1817A	37	Table VII. Sound System Indirect Registers	26
AD1817A FLAG BYTES	37	Table VIII. SoundBlaster Pro ISA Bus Registers	33
USING THE AD1817A WITHOUT AN EEPROM	39	Table IX. AdLib ISA Bus Registers	33
PIN MUXING IN THE AD1817A	39	Table X. MIDI ISA Bus Registers	33
PROGRAMMING EXTERNAL EEPROMS	41	Table XI. Game Port ISA Bus Registers	34
REFERENCE DESIGNS AND DEVICE DRIVERS	41	Table XIII. AD1817A Pin Muxing	39
OUTLINE DIMENSIONS	44		

SPECIFICATIONS

STANDARD TEST CONDITIONS UNLESS OTHERWISE NOTED

Temperature	25	°C
Digital Supply (V_{DD})	5.0	V
Analog Supply (V_{CC})	5.0	V
Sample Rate (F_S)	48	kHz
Input Signal Frequency	1008	Hz
Audio Output Passband	20 Hz to 20 kHz	
V_{IH}	5.0	V
V_{IL}	0	V

DAC Test Conditions

0 dB Attenuation
 Input Full Scale
 16-Bit Linear Mode
 100 k Ω Output Load
 Mute Off
 Measured at Line Output

ADC Test Conditions

0 dB Gain
 Input -3 dB Relative to Full Scale
 Line Input Selected
 16-Bit Linear Mode

ANALOG INPUT

Parameter	Min	Typ	Max	Units
Full-Scale Input Voltage (RMS Values Assume Sine Wave Input) PHONE_IN, LINE, SYNTH, CD		1		V rms
		2.83		V p-p
MIC with +20 dB Gain (MGE = 1)		0.1		V rms
		0.283		V p-p
MIC with 0 dB Gain (MGE = 0)		1		V rms
		2.83		V p-p
Input Impedance*		17		k Ω
Input Capacitance*		15		pF

PROGRAMMABLE GAIN AMPLIFIER—ADC

Parameter	Min	Typ	Max	Units
Step Size (0 dB to 22.5 dB) (All Steps Tested)		1.5		dB
PGA Gain Range Span		22.5		dB

CD, SYNTH, MICROPHONE, INPUT ANALOG GAIN/ATTENUATORS/MUTE

Parameter	Min	Typ	Max	Units
CD, SYNTH, MIC				
Step Size: (All Steps Tested) +12 dB to -34.5 dB		1.5		dB
Input Gain/Attenuation Range		46.5		dB
PHONE_IN				
Step Size 0 dB to -45 dB: (All Steps Tested)		3.0		dB
Input Gain/Attenuation Range		45		dB

AD1817A

DIGITAL DECIMATION AND INTERPOLATION FILTERS*

Parameter	Min	Typ	Max	Units
Audio Passband	0		$0.4 \times F_S$	Hz
Audio Passband Ripple			± 0.09	dB
Audio Transition Band	$0.4 \times F_S$		$0.6 \times F_S$	Hz
Audio Stopband	$0.6 \times F_S$		∞	Hz
Audio Stopband Rejection	82			dB
Audio Group Delay			$12/F_S$	sec
Group Delay Variation Over Passband			0.0	μ s

ANALOG-TO-DIGITAL CONVERTERS

Parameter	Min	Typ	Max	Units
Resolution		16		Bits
Signal-to-Noise Ratio (SNR) (A-Weighted, Referenced to Full Scale)		-82	-80	dB
Total Harmonic Distortion (THD) (Referenced to Full Scale)		0.011	0.015	%
			-79	dB
Audio Dynamic Range (-60 dB Input THD+N Referenced to Full Scale, A-Weighted)	79	82		dB
Audio THD+N (Referenced to Full-Scale)			0.019	%
			-76	dB
Signal-to-Intermodulation Distortion* (CCIF Method)		82	-74.5	dB
ADC Crosstalk*				
Line Inputs (Input L, Ground R, Read R; Input R, Ground L, Read L)			-95	dB
Line to MIC (Input LINE, Ground and Select MIC, Read ADC)			-95	dB
Line to SYNTH			-95	dB
Line to CD			-95	dB
Gain Error (Full-Scale Span Relative to Nominal Input Voltage)			± 10	%
Interchannel Gain Mismatch (Difference of Gain Errors)			± 1	dB
ADC Offset Error	-22		+15	mV

DIGITAL-TO-ANALOG CONVERTERS

Parameter	Min	Typ	Max	Units
Resolution		16		Bits
Signal-to-Noise Ratio (SNR) (A-Weighted)		-83	-79	dB
Total Harmonic Distortion (THD)		0.006	0.009	%
			-85	dB
Audio Dynamic Range (-60 dB Input THD+N Referenced to Full Scale, A-Weighted)	79	82		dB
Audio THD+N (Referenced to Full Scale)		0.013	0.017	%
			-78	dB
Signal-to-Intermodulation Distortion* (CCIF Method)		95		dB
Gain Error (Full-Scale Span Relative to Nominal Input Voltage)			± 10	%
Interchannel Gain Mismatch (Difference of Gain Errors)			± 0.5	dB
DAC Crosstalk* (Input L, Zero R, Measure R_OUT; Input R, Zero L, Measure L_OUT)			-80	dB
Total Out-of-Band Energy (Measured from $0.6 \times F_S$ to 100 kHz at L_OUT and R_OUT)*			-45	dB
Audible Out-of-Band Energy (Measured from $0.6 \times F_S$ to 20 kHz at L_OUT and R_OUT)*			-75	dB

MASTER VOLUME ATTENUATORS (L_OUT AND R_OUT, PHONE_OUT)

Parameter	Min	Typ	Max	Units
Master Volume Step Size (0 dB to -43.5 dB)		1.5		dB
Master Volume Step Size (-43.5 dB to -46.5 dB)		1.5		dB
Master Volume Output Attenuation Range Span		46.5		dB
Mute Attenuation of 0 dB Fundamental*	80			dB

DIGITAL MIX ATTENUATORS*

Parameter	Min	Typ	Max	Units
Step Size: Music, ISA		1.505		dB
Digital Mix Attenuation Range Span		94.8		dB

ANALOG OUTPUT

Parameter	Min	Typ	Max	Units
Full-Scale Output Voltage (at L_OUT, R_OUT, PHONE_OUT)		2.8		V p-p
Output Impedance*			570	Ω
External Load Impedance*	10			k Ω
Output Capacitance*		15		pF
External Load Capacitance			100	pF
V _{REFX} *	2.10	2.25	2.40	V
V _{REFX} Current Drive*		100		μ A
V _{REFX} Output Impedance*		6.5		k Ω
Mute Click (Muted Analog Mixers), Muted Output Minus Unmuted Output at 0 dB		\pm 5		mV

SYSTEM SPECIFICATIONS*

Parameter	Min	Typ	Max	Units
System Frequency Response Ripple (Line In to Line Out)			1.0	dB
Differential Nonlinearity			\pm 1	LSB
Phase Linearity Deviation			5	Degrees

STATIC DIGITAL SPECIFICATIONS

Parameter	Min	Typ	Max	Units
High Level Input Voltage (V _{IH})	2			V
XTALI	2.4			V
Low Level Input Voltage (V _{IL})			0.8	V
High Level Output Voltage (V _{OH}), I _{OH} = 8 mA [†]	2.4			V
Low Level Output Voltage (V _{OL}), I _{OL} = 8 mA			0.4	V
Input Leakage Current	-10		+10	μ A
Output Leakage Current	-10		+10	μ A

POWER SUPPLY

Parameter	Min	Typ	Max	Units
Power Supply Range—Analog	4.75		5.25	V
Power Supply Range—Digital	4.75		5.25	V
Power Supply Current			221	mA
Power Dissipation			1105	mW
Analog Supply Current			51	mA
Digital Supply Current			170	mA
ACPI Power-Down Modes				
D0 Analog Supply Current		47		mA
D0 Digital Supply Current		120		mA
D1 Analog Supply Current		20		mA
D1 Digital Supply Current		20		mA
D2 Analog Supply Current		10		mA
D2 Digital Supply Current		18		mA
D3 Analog Supply Current		0		mA
D3 Digital Supply Current		6		mA
Digital Power Supply Current—Power-Down			24	mA
Analog Power Supply Current—RESET			0.2	mA
Digital Power Supply Current—RESET			10	mA
Power Supply Rejection (100 mV p-p Signal @ 1 kHz)* (At Both Analog and Digital Supply Pins, Both ADCs and DACs)		40		dB

AD1817A

CLOCK SPECIFICATIONS*

Parameter	Min	Typ	Max	Units
Input Clock Frequency		14.31818		MHz
Recommended Clock Duty Cycle	25	50	75	%
Power-Up Initialization Time			500	ms

TIMING PARAMETERS (Guaranteed Over Operating Temperature Range)

Parameter	Symbol	Min	Typ	Max	Units
$\overline{IOW}/\overline{IOR}$ Strobe Width	t_{STW}	100			ns
$\overline{IOW}/\overline{IOR}$ Rising to $\overline{IOW}/\overline{IOR}$ Falling	t_{BWDN}	80			ns
Write Data Setup to \overline{IOW} Rising	t_{WDSU}	10			ns
\overline{IOW} Falling to Valid Read Data	t_{RDDV}			40	ns
AEN Setup to $\overline{IOW}/\overline{IOR}$ Falling	t_{AESU}	10			ns
AEN Hold from $\overline{IOW}/\overline{IOR}$ Rising	t_{AEHD}	0			ns
Adr Setup to $\overline{IOW}/\overline{IOR}$ Falling	t_{ADSU}	10			ns
Adr Hold from $\overline{IOW}/\overline{IOR}$ Rising	t_{ADHD}	0			ns
\overline{DACK} Rising to $\overline{IOW}/\overline{IOR}$ Falling	t_{DKSU}	20			ns
Data Hold from \overline{IOR} Rising	t_{DHD1}			2	ns
Data Hold from \overline{IOW} Rising	t_{DHD2}	15			ns
\overline{DRQ} Hold from $\overline{IOW}/\overline{IOR}$ Falling	t_{DRHD}			25	ns
\overline{DACK} Hold from $\overline{IOW}/\overline{IOR}$ Rising	t_{DKHD}	10			ns
Data [SDI] Input Setup Time to SCLK*	t_S	15			ns
Data [SDI] Input Hold Time from SCLK*	t_H	10			ns
Frame Sync [SDFS] HI Pulse Width*	t_{FSW}		80		ns
Clock [SCLK] to Frame Sync [SDFS] Propagation Delay*	t_{PD}			15	ns
Clock [SCLK] to Output Data [SDO] Valid*	t_{DV}			15	ns
RESET Pulse Width	t_{RPWL}	100			ns
BCLK HI Pulse Width	t_{DBH}	25			ns
BCLK LO Pulse Width	t_{DBL}	25			ns
BCLK Period	t_{DBP}	50			ns
LRCLK Setup	t_{DLS}	5			ns
SDATA Setup	t_{DDS}	5			ns
SDATA Hold	t_{DDH}	5			ns

NOTES

*Guaranteed, not tested.

†(All ISA pins MIDI_OUT IOL = 24 mA. Refer to pin description for individual output drive levels.

Specifications subject to change without notice.

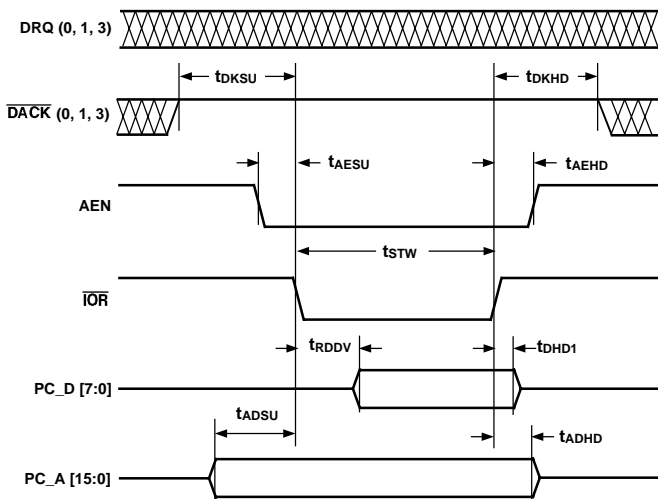

Figure 1. PIO Read Cycle

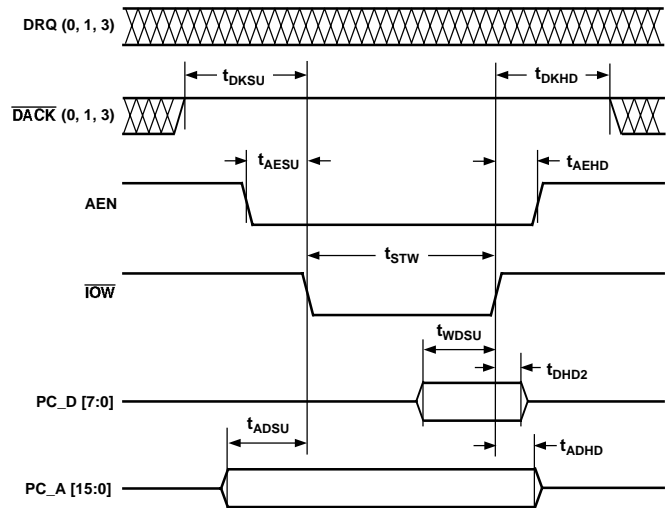

Figure 2. PIO Write Cycle

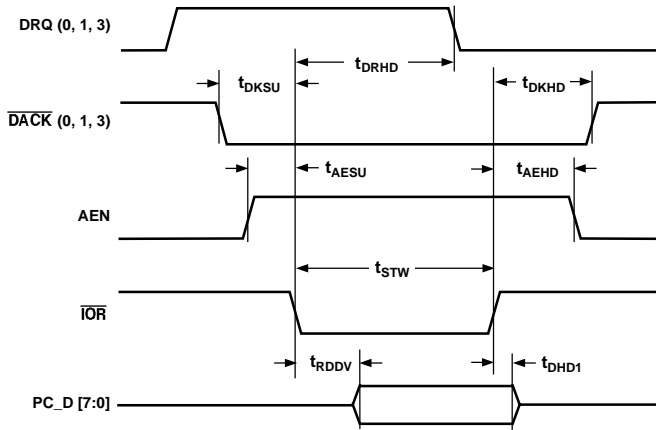

Figure 3. DMA Read Cycle

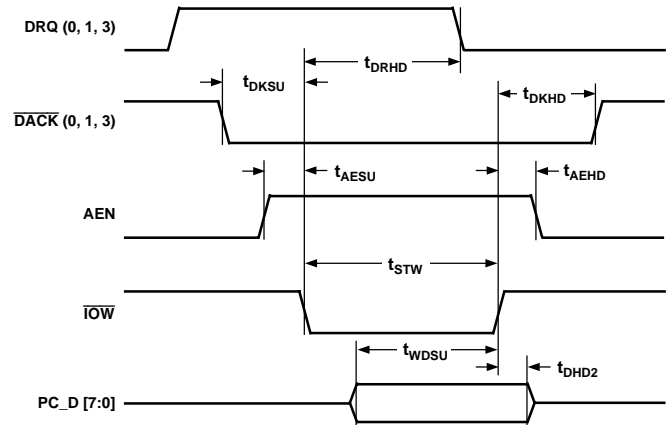

Figure 5. DMA Write Cycle

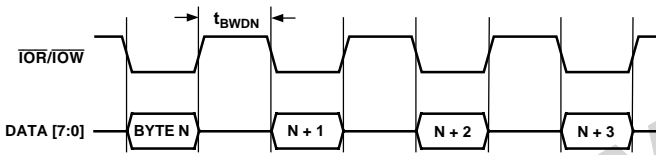

Figure 4. Codec Transfers

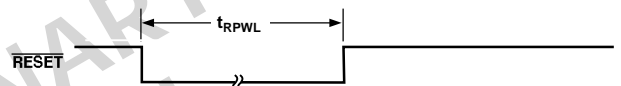

Figure 6. Reset Pulse Width

PRELIMINARY
TECHNICAL
DATA

AD1817A

ABSOLUTE MAXIMUM RATINGS*

Parameter	Min	Max	Units
Power Supplies			
Digital (V_{DD})	-0.3	6.0	V
Analog (V_{CC})	-0.3	6.0	V
Input Current (Except Supply Pins)		± 10.0	mA
Analog Input Voltage (Signal Pins)	-0.3	$V_{CC} + 0.3$	V
Digital Input Voltage (Signal Pins)	-0.3	$V_{DD} + 0.3$	V
Ambient Temperature (Operating)	0	+70	$^{\circ}\text{C}$
Storage Temperature	-65	+150	$^{\circ}\text{C}$

*Stresses greater than those listed under Absolute Maximum Ratings may cause permanent damage to the device. This is a stress rating only; functional operation of the device at these or any other conditions above those indicated in the operational section of this specification is not implied. Exposure to absolute maximum rating conditions for extended periods may affect device reliability.

ENVIRONMENTAL CONDITIONS

Ambient Temperature Rating:

$$T_{\text{AMB}} = T_{\text{CASE}} - (\text{PD} \times \theta_{\text{CA}})$$

T_{CASE} = Case Temperature in $^{\circ}\text{C}$

PD = Power Dissipation in W

θ_{CA} = Thermal Resistance (Case-to-Ambient)

θ_{JA} = Thermal Resistance (Junction-to-Ambient)

θ_{JC} = Thermal Resistance (Junction-to-Case)

Package	θ_{JA}	θ_{JC}	θ_{CA}
PQFP	77 $^{\circ}\text{C}/\text{W}$	7 $^{\circ}\text{C}/\text{W}$	70 $^{\circ}\text{C}/\text{W}$

ORDERING GUIDE

Model	Temperature Range	Package Description	Package Option*
AD1817AJS	0 $^{\circ}\text{C}$ to +70 $^{\circ}\text{C}$	100-Lead PQFP	S-100

*S = Plastic Quad Flatpack.

CAUTION

ESD (electrostatic discharge) sensitive device. Electrostatic charges as high as 4000 V readily accumulate on the human body and test equipment and can discharge without detection. Although the AD1817A features proprietary ESD protection circuitry, permanent damage may occur on devices subjected to high energy electrostatic discharges. Therefore, proper ESD precautions are recommended to avoid performance degradation or loss of functionality.

The AD1817A latchup immunity has been demonstrated at $\geq +100$ mA/ -80 mA on all pins when tested to Industry Standard/JEDEC methods.



AD1817A

PIN FUNCTION DESCRIPTIONS

Analog Signals

Pin Name	PQFP	I/O	Description
MIC	44	I	Microphone Input. The MIC input may be either line-level or -20 dB from line-level (the difference being made up through a software controlled 20 dB gain block). The mono MIC input may be sent to the left and right channel of the ADC for conversion, or gained/attenuated from +12 dB to -34.5 dB in 1.5 dB steps and then summed with left and right line OUT before the Master Volume stage.
L_LINE	42	I	Left Line-Level Input. The left line-level input may be: sent to the left channel of the ADC; gained/attenuated from +12 dB to -34.5 dB in 1.5 dB steps and then summed with left line OUT.
R_LINE	41	I	Right Line-Level Input. The right line-level input may be: sent to the right channel of the ADC; gained/attenuated from +12 dB to -34.5 dB in 1.5 dB steps and then summed with right line OUT.
L_SYNTH	46	I	Left Synthesizer Input. The left MIDI upgrade line-level input may be: sent to the left channel of the ADC; gained/attenuated from +12 dB to -34.5 dB in 1.5 dB steps and then summed with left line OUT.
R_SYNTH	45	I	Right Synthesizer Input. The right MIDI upgrade line-level input may be: sent to the right channel of the ADC; gained/attenuated from +12 dB to -34.5 dB in 1.5 dB steps and then summed with right line OUT.
L_CD	48	I	Left CD Line-Level Input. The left CD line-level input may be: sent to the left channel of the ADC; gained/attenuated from +12 dB to -34.5 dB in 1.5 dB steps and then summed with left line OUT.
R_CD	47	I	Right CD Line-Level Input. The right CD line-level input may be: sent to the right channel of the ADC; gained/attenuated from +12 dB to -34.5 dB in 1.5 dB steps and then summed with right line OUT.
L_OUT	30	O	Left Output. Left channel line-level post-mixed output. The final stage passes through the Master Volume block and may be attenuated 0 dB to -45 dB in 1.5 dB steps.
R_OUT	29	O	Right Output. Right channel line-level post-mixed output. The final stage passes through the Master Volume block and may be attenuated 0 dB to -45 dB in 1.5 dB steps.
PHONE_IN	43	I	Phone Input. Line-level input from a DAA/modem chipset.
PHONE_OUT	28	O	Phone Output. Line-level output from a DAA/modem chipset.

Parallel Interface (All Outputs are 24 mA Drivers)

Pin Name	PQFP	I/O	Description
PC_D[7:0]	85–88, 91–94	I/O	Bidirectional ISA Bus PC Data, 24 mA drive. Connects the AD1817A to the low byte data on the bus.
IRQ(x)*	75–81, 83	O	Host Interrupt Request, 24 mA drive. IRQ (3)/IRQ (9), IRQ(5), IRQ(7), IRQ(9)/IRQ (14), IRQ(10)/IRQ(4), IRQ(11)/IRQ (9)/IRQ (4), IRQ(12)/IRQ(13), IRQ(15)/IRQ (11). Active HI signals indicating a pending interrupt.
DRQ(x)	72–74	O	DMA Request, 24 mA drive. DRQ(0), DRQ(1), DRQ(3). Active HI signals indicating a request for DMA bus operation.
PC_A[15:0]	4–19	I	ISA Bus PC Address. Connects the AD1817A to the ISA bus address lines.
AEN	20	I	Address Enable. Low signal indicates a PIO transfer.
$\overline{\text{DACK}}$ (x)	59–61	I	DMA Acknowledge. DACK(0), DACK(1), DACK(3). Active LO signal indicating that a DMA operation can begin.
$\overline{\text{IOR}}$	22	I	I/O Read. Active LO signal indicates a read operation.
$\overline{\text{IOW}}$	21	I	I/O Write. Active HI signal indicates a write operation.
RESET	25	I	Reset. Active HI.

Game Port

Pin Name	PQFP	I/O	Description
A_1	50	I	Game Port A, Button #1.
A_2	49	I	Game Port A, Button #2.
A_X	54	I	Game Port A, X-Axis.
A_Y	53	I	Game Port A, Y-Axis.
B_1	52	I	Game Port B, Button #1.
B_2	51	I	Game Port B, Button #2.
B_X	56	I	Game Port B, X-Axis.
B_Y	55	I	Game Port B, Y-Axis.

MIDI Interface Signal (24 mA Drivers)

Pin Name	PQFP	I/O	Description
MIDI_IN	66	I	RXD MIDI Input. This pin is typically connected to Pin 15 of the game port connector.
MIDI_OUT	67	O	TXD MIDI Output. This pin is typically connected to Pin 12 of the game port connector.

AD1817A

Miscellaneous Analog Pins

Pin Name	PQFP	I/O	Description
V _{REF_X}	36	O	Voltage Reference. Nominal 2.25 volt reference available for dc-coupling and level-shifting. V _{REF_X} should not be used to sink or source signal current.
V _{REF}	35	I	Voltage Reference Filter. Voltage reference filter point for external bypassing only.
L_FILT	38	I	Left Channel Filter. Requires a 1.0 μF to analog ground for proper operation.
R_FILT	37	I	Right Channel Filter. Requires a 1.0 μF to analog ground for proper operation.
L_AAFILT	40	I	Left Channel Antialias Filter. This pin requires a 270 pF NPO capacitor to analog ground for proper operation.
R_AAFILT	39	I	Right Channel Antialias Filter. This pin requires a 270 pF NPO capacitor to analog ground for proper operation.

Crystal Pin

Pin Name	PQFP	I/O	Description
XTALO	64	O	14.31818 MHz Crystal Output. If no Crystal is present leave XTALO unconnected.
XTALI	63	I	14.31818 MHz Clock. When using a crystal as a clock source, the crystal should be connected between the XTALI and XTALO pins. Clock input may be driven into XTALI in place of a crystal. When using an external clock, V _{IH} must be 2.4 V rather than the V _{IH} of 2.0 V specified for all other digital inputs.

External Logical Devices

Pin Name	PQFP	I/O	Description
LD_IRQ*	100	I	Logical Device IRQ.
LD_DACK*	99	O	Logical Device DACK.
LD_DRQ*	98	I	Logical Device DRQ.
LD_SEL*	97	O	Logical Device Select.
MDM_SEL*	83	O	Modem Chip Set Select.
MDM_IRQ*	82	I	Modem Chip Set IRQ.
LD_SEL1*	69	O	Logical Device (1) Select.
PNPRST*	68	O	Plug and Play Reset.

Hardware Volume Pins

Pin Name	PQFP	I/O	Description
$\overline{\text{VOL_DN}}^*$	2, 99, 100	I	Master Volume Down. Modifies output level on pins L_OUT and R_OUT. Contains a 10 k Ω internal pull-up resistor. When asserted LO, decreases Master Volume by 1.5 dB/sec. Must be asserted at least 25 ms to be recognized. When asserted simultaneously with VOL_UP, output is muted. Output level modification reflected in indirect register 0 \times 29.
$\overline{\text{VOL_UP}}^*$	1, 98	I	Master Volume Up. Modifies output level on pins L_OUT and R_OUT. Contains a 10 k Ω internal pull-up resistor. When asserted LO, increases Master Volume by 1.5 dB/sec. Must be asserted at least 25 ms to be recognized. When asserted simultaneously with VOL_UP, output is muted. Output level modification reflected in indirect register 0 \times 29.
A_VOL	31	I	Analog Volume Control Input.

Control Pins

Pin Name	PQFP	I/O	Description
XCTL0*	68	O	External Control 0. The state of this pin (TTL HI or LO) is reflected in codec indexed register. This pin is an open drain driver.
XCTL1*	69	O	External Control 1. The state of this pin (TTL HI or LO) is reflected in codec indexed register. Open drain, 8 mA active 0.5 mA pull-up resistor.
RING*	69	I	Ring Indicator. Used to accept the ring indicator flag from the DAA.

Power Supplies

Pin Name	PQFP	I/O	Description
V _{CC}	33	I	Analog Supply Voltage (+5 V).
G _{NDA}	34	I	Analog Ground.
V _{DD}	23, 62, 71, 89, 95	I	Digital Supply Voltage (+5 V).
G _{ND}	3*, 24, 65, 70, 84, 90, 96, 99*, 100*	I	Digital Ground.
NC	26, 27, 32		No Connect.

Optional EEPROM Pins

Pin Name	PQFP	I/O	Description
EE_CLK	58	O	EEPROM Clock.
EE_DATA	57	I	EEPROM Data.

*The position of this pin location/function is dependent on the EEPROM data.

AD1817A

HOST INTERFACE

The AD1817A contains all necessary ISA bus interface logic on chip. This logic includes address decoding for all onboard resources, control and signal interpretation, DMA selection and control logic, IRQ selection and control logic, and all interface configuration logic.

The AD1817A supports a Type “F” DMA request/grant architecture for transferring data with the ISA bus through the 8-bit interface. The AD1817A also supports DACK preemption. Programmed I/O (PIO) mode is also supported for control register accesses and for applications lacking DMA control. The AD1817A includes dual DMA count registers for full-duplex operation enabling simultaneous capture and playback on separate DMA channels.

Codec Functional Description

The AD1817A’s full-duplex stereo codec supports business audio and multimedia applications. The codec includes stereo audio converters, complete on-chip filtering, MPC Level-2 and Level-3 compliant analog mixing, programmable gain and attenuation, a variable sample rate converter, extensive digital mixing and FIFOs buffering the Plug and Play ISA bus interface.

Analog Inputs

The codec contains a stereo pair of $\Sigma\Delta$ analog-to-digital converters (ADC). Inputs to the ADC can be selected from the following analog signals: mono (PHONE_IN), mono microphone (MIC), stereo line (LINE), external stereo synthesizer (SYNTH), stereo CD ROM (CD), and post-mixed stereo or mono line output (OUT).

Analog Mixing

MIC, SYNTH and CD can be mixed in the analog domain with the stereo line OUT from the $\Sigma\Delta$ digital-to-analog converters (DAC). Each channel of the stereo analog inputs can be independently gained or attenuated from +12 dB to -34.5 dB in 1.5 dB steps. The summing path for the mono inputs (MIC, and PHONE_IN to line OUT) duplicates mono channel data on both the left and right line OUT, which can also be gained or attenuated from +12 dB to -34.5 dB in 1.5 dB steps for MIC. The left and right mono summing signals are always identical being gained or attenuated equally.

Analog-to-Digital Datapath

The selector sends left and right channel information to the programmable gain amplifier (PGA). The PGA following the selector allows independent gain for each channel entering the ADC from 0 dB to 22.5 dB in 1.5 dB steps.

For supporting time correlated I/O echo cancellation, the ADC is capable of sampling microphone data on the left channel and the mono summation of left and right OUT on the right channel.

The codec can operate in either a global stereo mode or a global mono mode with left channel inputs appearing at both channels of the 16-bit $\Sigma\Delta$ converters. Data can be sampled at the programmed sampling frequency (from 4 kHz to 55.2 kHz with 1 Hz resolution).

Digital Mixing and Sample Rates

The audio ADC sample rate and the audio DAC sample rates are completely independent. The AD1817A includes a variable sample rate converter that lets the codec instantaneously change and process sample rates from 4 kHz to 55.2 kHz with a resolution of 1 Hz. The in-band integrated noise and distortion artifacts introduced by rate conversions are below -90 dB.

Up to four channels of digital data can be summed together and presented to the stereo DAC for conversion. Each digital channel pair can contain information encoded at a different sample rate.

Digital-to-Analog Datapath

The internally generated music synthesizer data, and PCM data received from the ISA interface, passes through an attenuation mute stage. The attenuator allows independent control over each digital channel, which can be attenuated from 0 dB to -94.5 dB in 1.5 dB steps before being summed together and passed to the DAC, or the channel may be muted entirely.

Analog Outputs

The analog output of the DAC can be summed with any of the analog input signals. The summed analog signal enters the Master Volume stage where each channel L_OUT, R_OUT and PHONE_OUT may be attenuated from 0 dB to -46.5 dB in 1.5 dB steps or muted.

Digital Data Types

The codec can process 16-bit twos-complement PCM linear digital data, 8-bit unsigned magnitude PCM linear data and 8-bit μ -law or A-law companded digital data as specified in the control registers. The AD1817A also supports ADPCM encoded in the Creative SoundBlaster ADPCM formats.

ACPI Power-Down Modes

The AD1817A complies with the four device power states defined in the ACPI Audio Device Class Specification. The device power states support the On Now Architecture, which works in conjunction with future operating systems from Microsoft.

In the D0 state, the AD1817A is fully running. D1 powers down the digital codec converters, and the OPL3-compatible music synthesizer, lowering power consumption. The D2 state powers down the analog and digital codec converters, and the OPL3-compatible music synthesizer. The D2 state keeps the analog mixer alive. D3 places the AD1817A into the lowest power state in which all device context is lost.

Host-Based Echo Cancellation Support

The AD1817A supports time correlated I/O data format by presenting MIC data on the left channel of the ADC and the mono summation of left and right OUT on the right channel. The ADC sample rates are independent of the DAC sample rate allowing the AD1817A to support ADC time correlated I/O data at 8 kHz and DAC data at any other sample rate in the range of 4 kHz to 55.2 kHz simultaneously.

Telephony Support

The AD1817A contains a PHONE_IN input and a PHONE_OUT output. These pins are supplied so the AD1817A may be connected to a modem chip set, a telephone handset or down-line phone.

WSS and SoundBlaster Compatibility

Windows Sound System software audio compatibility is built into the AD1817A.

SoundBlaster emulation is provided through the SoundBlaster register set and the internal music synthesizer. SoundBlaster Pro version 2.01 functions are supported, including record and Creative SoundBlaster ADPCM.

Virtually all applications developed for SoundBlaster, Windows Sound System, AdLib and MIDI MPU-401 platforms run on the AD1817A SoundPort® Controller. Follow the same development process for the controller as you would for these other devices.

The AD1817A contains SoundBlaster (compatible) and Sound System logical devices. You may find the following related development kits useful when developing AD1817A applications.

Developer Kit for SoundBlaster Series, 2nd ed. © 1993, Creative Labs, Inc., 1901 McCarthy Blvd., Milpitas, CA 95035
Microsoft Windows Sound System Driver Development Kit (CD), Version 2.0, © 1993, Microsoft Corp., One Microsoft Way, Redmond, WA 98052

The following reference texts can serve as additional sources of information on developing applications that run on the AD1817A.

S. De Furia & J. Scacciaferro, *The MIDI Implementation Book*, (© 1986, Third Earth, Pompton Lake)
 C. Petzold, *Programming Windows: the Microsoft guide to writing applications for Windows 3.1*, 3rd. ed., (© 1992, Microsoft Press, Redmond)
 K. Pohlmann, *Principles of Digital Audio*, (© 1989, Sams, Indianapolis)
 A. Stolz, *The SoundBlaster Book*, (© 1993, Abacus, Grand Rapids)
 J. Strawn, *Digital Audio Engineering. An Anthology*, (© 1985, Kaufmann, Los Altos)
 Yamamoto, *MIDI Guidebook*, 4th. ed., (© 1987, 1989, Roland Corp.)

Multimedia PC Capabilities

The AD1817A is MPC-2 and MPC-3 compliant. This compliance is achieved through the AD1817A's flexible mixer and the embedded chip resources.

Music Synthesis

The AD1817A includes an embedded music synthesizer that emulates industry standard OPL3 FM synthesizer chips and delivers 20 voice polyphony. The internal synthesizer generates digital music data at 22.05 kHz and is summed into the DACs digital data stream prior to conversion. To sum synthesizer data with the ADC output, the ADC must be programmed for a 22.05 kHz sample rate.



The synthesizer is a hardware implementation of Eusynth-1+ code that was developed by Euphonics, a research and development company that specializes in audio processing and electronic music synthesis.

MIDI

The primary interface for communicating MIDI data to and from the host PC is the compatible MPU-401 interface that operates in UART mode. The MPU-401 interface has two built-in FIFOs: a 64 byte receive FIFO and a 16 byte transmit FIFO.

Game Port

An IBM-compatible game port interface is provided on chip. The game port supports up to two joysticks via a 15-pin D-sub connector. Joystick registers supporting the Microsoft

Direct Input standard are included as part of the register map. The AD1817A may be programmed to automatically sample the game port and save the value in the Joystick Position Data Register. When enabled, this feature saves up to 10% CPU MIPS by off-loading the host from constantly polling the joystick port.

Volume Control

The registers that control the Master Volume output stage are accessible through the parallel port. Master Volume output can also be controlled through a 2-pin hardware interface. One pin is used to increase the gain, the other pin attenuates the output and both pins together entirely mute the output. Once muted, any further activity of these pins will unmute the AD1817A's output. The AD1817A also contains an analog input for connecting to PCs with front panel potentiometers used to control the volume. The digital volume control, analog volume control and the software volume control may all be used in the same system.

Plug and Play Configuration

The AD1817A is fully Plug and Play configurable. For motherboard applications, the built-in Plug and Play protocol can be disabled with a software key providing a back door for the BIOS to configure the AD1817A's logical devices. For information on the Plug and Play mode configuration process, see the *Plug and Play ISA Specification Version 1.0a (May 5, 1994)*. All the AD1817A's logical devices comply with Plug and Play resource definitions described in the specification.

The AD1817A may alternatively be configured using an optional Plug and Play Resource ROM. When the EEPROM is present, some additional AD1817A muxed-pin features become available. For example, pins that control an external modem logical device are muxed with the DSP serial port. Some of these pin option combinations are mutually exclusive (see Appendix A for more information).

REFERENCES

The AD1817A also complies with the following related specifications; they can be used as an additional reference to AD1817A operations beyond the material in this data sheet.

Plug and Play ISA Specification, Version 1.0a, © 1993, 1994, Intel Corp. & Microsoft Corp., One Microsoft Way, Redmond, WA 98052

Multimedia PC Level 2 Specification, © 1993, Multimedia PC Marketing Council, 1730 M St. NW, Suite 707, Washington, DC 20036

MIDI 1.0 Detailed Specification & Standard MIDI Files 1.0, © 1994, MIDI Manufacturers Association, PO Box 3173 La Habra, CA 90632-3173

Recommendation G.711-Pulse Code Modulation (PCM) Of Voice Frequencies (μ-Law & A-Law Companding), The International Telegraph and Telephone Consultative Committee IX Plenary Assembly Blue Book, Volume III - Fascicle III.4, General Aspects Of Digital Transmission Systems; Terminal Equipment's, Recommendations G.700 - G.795, (Geneva, 1988), ISBN 92-61-03341-5

IMA Digital Audio Doc-Pac (IMA-ADPCM), © 1992, Interactive Multimedia Association, 48 Maryland Avenue, Suite 202, Annapolis, MD 21401-8011

AD1817A

ISA INTERFACE

AD1817A Chip Registers

Table I, Chip Register Diagram, details the AD1817A direct register set available from the ISA Bus. Prior to any accesses by the host, the PC I/O addressable ports must be configured using the Plug and Play Resources.

Table I. Chip Register Diagram

Register Type-Register Name	Register PC I/O Address
<i>Plug and Play</i> ADDRESS WRITE_DATA READ_DATA	0x279 0xA79 Relocatable in Range 0x203 – 0x3FF
<i>Sound System Codec</i> CODEC REGISTERS	0x(SS Base+0 – SS Base+15) Relocatable in Range 0x100 – 0x3FF See Table V
<i>SoundBlaster Pro</i> Music0: Address (w), Status (r) Music0: Data (w) Music1: Address (w) Music1: Data (w) Mixer Address (w) Mixer Data (w) Reset (w) Music0: Address (w) Music0: Data (w) Input Data (r) Status (r), Output Data (w) Status (r) Music0: Address (w), Status (r) Music0: Data (w) Music1: Address (w) Music1: Data (w)	0x(SB Base) Relocatable in Range 0x010 – 0x3F0 0x(SB Base+1) 0x(SB Base+2) 0x(SB Base+3) 0x(SB Base+4) 0x(SB Base+5) 0x(SB Base+6 or 7) 0x(SB Base+8) 0x(SB Base+9) 0x(SB Base+A or +B) 0x(SB Base+C or +D) 0x(SB Base+E or +F) 0x(AdLib Base) Relocatable in Range 0x100 – 0x3F8 0x(AdLib Base+1) 0x(AdLib Base+2) 0x(AdLib Base+3)
<i>MIDI MPU-401</i> MIDI Data (r/w) MIDI Status (r), Command (w)	0x(MIDI Base) Relocatable in Range 0x100 – 0x3F8 0x(MIDI Base+1)
<i>Game Port</i> Game Port I/O	0x(Game Base +0 to Game Base +7) Relocatable in Range 0x100 – 0x3F8

AD1817A Plug and Play Device Configuration Registers

The AD1817A may be configured according to the Intel/Microsoft Plug and Play Specification using the internal ROM. Alternatively, the PnP configuration sequence may be bypassed using the “Alternate Key Sequence” described in Appendix A.

The operating system configures/reconfigures AD1817A Plug and Play Logical Devices after system boot. There are no “boot-devices” among the Plug and Play Logical Devices in the AD1817A. Non-Plug and Play BIOS systems configure the AD1817A’s Logical Devices after boot using drivers. Depending on BIOS implementations, Plug and Play BIOS systems may configure the AD1817A’s Logical Devices before POST or after Boot. See the *Plug and Play ISA Specification Version 1.0a* for more information on configuration control. To complete this configuration, the system reads resource data from the AD1817A’s on-chip resource ROM and from any other Plug and Play cards in the system, and then arbitrates the configuration of system resources with a heuristic algorithm. The algorithm maximizes the number of *active* devices and the *acceptability* of their configurations.

The system considers all Plug and Play logical device resource data at the same time and makes a conflict-free assignment of resources to the devices. If the system cannot assign a conflict-free resource to a device, the system does not configure or activate the device. All configured devices are activated.

The system’s Plug and Play support selects all necessary drivers, starts them and maintains a list of system resources allocated to each logical device. As an option, system resources can be reassigned at runtime with a Plug and Play Resource Manager. The custom setup created using the manager can be saved and used automatically on subsequent system boots.

Plug and Play Device IDs (embedded in the logical device's resource data) provide the system with the information required to find and load the correct device drivers. One custom driver, the AD1817A Sound System driver from Analog Devices, is required for correct operation. In the other cases (MIDI, Game Port), the system can use generic drivers. Table II lists the AD1817A's Logical Devices and compatible Plug and Play device drivers.

Table II. Logical Devices and Compatible Plug and Play Device Drivers

Logical Device Number	Emulated Device	Compatible (Device ID)	Device ID
0	Sound System	—	ADS7180
1	MIDI MPU401 Compatible	PNPB006	ADS7181
2	Game/Joystick Port	PNPB02F	ADS7182

The configuration process for the logical devices on the AD1817A is described in the *Plug and Play ISA Specification Version 1.0a (May 5, 1994)*. The specification describes how to transfer the logical devices from their start-up *Wait For Key* state to the *Config* state and how to assign I/O ranges, interrupt channels and DMA channels. See Appendix A for an example setup program and specific Plug and Play resource data.

Table III describes in detail the I/O Port Address Descriptors, DMA Channels, Interrupts for the functions required for the AD1817A Logical Device groups.

Table III. Logical Device Configuration

LDN	PnP Function	Description
0	I/O Port Address Descriptor (0x60-0x61)	The SoundBlaster Pro address range is from 0x100 to 0x3F0. The typical address is 0x220. The range is 16-bytes long and must be aligned to a 16-byte memory boundary.
0	I/O Port Address Descriptor (0x62-0x63)	The AdLib address range is from 0x100 to 0x3F8. The typical address is 0x388. The range is 4-bytes long and must be aligned to an 8-byte memory boundary.
0	I/O Port Address Descriptor (0x64-0x65)	The Codec address range is from 0x100 to 0x3F8. The range is 16-bytes long and must be aligned to a 16-byte memory boundary.
0	Interrupt Request Level Select (0x70-0x71)	This IRQ is shared between the SB Pro device and the Codec. These devices require one of the following IRQ channels: 5, 7, 9, 11, 12 or 15. Typically, the IRQ is set to 5 or 7 for this device.
0	DMA Playback Channel Select (0x74)	This 8-bit channel is shared between the SB Pro device and the Codec for playback. These devices require one of the following DMA channels: 0, 1, 3. Typically, DMA channel 1 is set.
0	DMA Capture Channel Select (0x75)	This the DMA channel used for capturing Codec data. The Codec operates in single-channel mode if a separate DMA channel for capture and playback is not assigned. The following DMA channels may be programmed: 0, 1, 3. DMA Channel 4 indicates single-channel mode.
1	I/O Port Address Descriptor (0x60-0x61)	The MPU-401 compatible device address range is 0x100 to 0x3FE. Typical configurations use 0x330. The range is 2-bytes long and must be aligned to a 2-byte memory boundary.
1	Interrupt Request Level Select (0x70-0x71)	The MIDI device requires one of the following IRQ channels: 5, 7, 9, 11, 12 or 15.
2	I/O Port Address Descriptor (0x60-0x61)	The Game Port address range is from 0x100 to 0x3F8. The typical address is 0x200. The range is 8-bytes long and must be aligned to an 8-byte memory boundary.

NOTE

DMA channel 4 indicates single-channel mode.

AD1817A

Sound System Direct Registers

The AD1817A has a set of 16 programmable Sound System Direct Registers and 36 Indirect Registers. This section describes all the AD1817A registers and gives their address, name and initialization state/reset value. Following each register table is a list (in ascending order) of the full register name, its usage and its type: (RO) Read Only, (WO) Write Only, (STKY) Sticky, (RW) Read Write and Reserved (res). Table IV is a map of the AD1817A direct registers.

Table IV. Sound System Direct Registers

Direct Address	Bit 7	Bit 6	Bit 5	Bit 4	Bit 3	Bit 2	Bit 1	Bit 0
SSBASE + 0	CRDY	VBL	INADR[5:0]					
SSBASE + 1	PI	CI	TI	VI	RES	RI	RES	SI
SSBASE + 2	Indirect SS Data [7:0]							
SSBASE + 3	Indirect SS Data [15:8]							
SSBASE + 4	RES		PUR	COR	ORR [1:0]		ORL [1:0]	
SSBASE + 5	PFH	PDR	PLR	PUL	CFH	CDR	CLR	CUL
SSBASE + 6	PIO Playback/Capture [7:0]							
SSBASE + 7	RESERVED							
SSBASE + 8	TRD	DAZ	PFMT [1:0]		PC/L	PST	PIO	PEN
SSBASE + 9	RES		CFMT [1:0]		PC/L	CST	CIO	CEN
SSBASE + 10	RES				ADPN	DPDN	SUSP	RD_MODE
SSBASE + 11	RESERVED							
SSBASE + 12	RESERVED							
SSBASE + 13	RESERVED							
SSBASE + 14	RESERVED							
SSBASE + 15	RESERVED							

[Base+0] Chip Status/Indirect Address

7	6	5	4	3	2	1	0	
CRDY	VBL	INADR[5:0]						RESET = [0x00]

INADR [5:0] (RW) Indirect Address for Sound System (SS). These bits are used to access the Indirect Registers shown in Table VIII. All registers data must be written in pairs, low byte followed by high byte, by loading the Indirect SS Data Registers, (Base +2) and (Base +3).

VBL Volume Button Location. When using an EEPROM to configure the PnP state of the AD1817A, this bit determines whether PQFP Pins 1 and 2 are used for VOL_UP and VOL_DN .
 0 No Function
 1 VOL_UP and VOL_DN

CRDY (RO) AD1817A Ready. The AD1817A asserts this bit when AD1817A can accept data.
 0 AD1817A not ready
 1 AD1817A ready

[Base+1] Interrupt Status

7	6	5	4	3	2	1	0	
PI	CI	TI	VI	RES	RI	RES	SI	RESET = [0x00]

SI (RO) SoundBlaster generated Interrupt.

0 No interrupt
 1 SoundBlaster interrupt pending

RI (RW) Ring Interrupt (Sticky, Write "0" to Clear).

0 No interrupt
 1 An interrupt is pending due to a Hardware Ring pin being asserted

VI (RW) Volume Interrupt (Sticky, Write "0" to Clear).

0 No interrupt
 1 An interrupt is pending due to Hardware Volume Button being pressed

TI (RW) Timer Interrupt. This bit indicates there is an interrupt pending from the timer count registers. (Sticky, Write "0" to Clear).

0 No interrupt
 1 Interrupt is pending from the timer count register

- CI (RW) Capture Interrupt. This bit indicates that there is an interrupt pending from the capture DMA count register. (Sticky, Write “0” to Clear).
 0 No interrupt
 1 Interrupt is pending from the capture DMA count register
- PI (RW) Playback Interrupt. This bit indicates that there is an interrupt pending from the playback DMA count register. (Sticky, Write “0” to Clear).
 0 No interrupt
 1 Interrupt is pending from the playback DMA count register

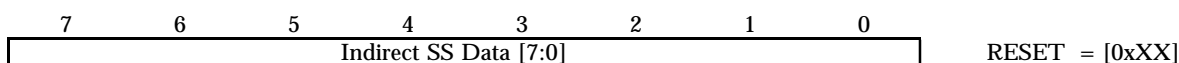
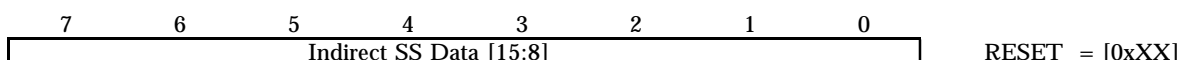
[Base+2] Indirect SS Data Low Byte**[Base+3] Indirect SS Data High Byte**

Indirect SS Data [15:0] Indirect Sound System Data. Data in this register is written to the Sound System Indirect Register specified by the address contained in INDAR [5:0], Sound System Direct Register [Base +0]. Data is written when the Indirect SS Data High Byte value is loaded.

[Base+4] PIO Debug

All bits in this register are sticky until any write that clears all bits to 0.

- ORL/ORR (RO) [1:0] Overrange Left/Right detect. These bits record the largest output magnitude on the ADC right and left channels and are cleared to 00 after any write to this register. The peak amplitude as recorded by these bits is “sticky,” i.e., the largest output magnitude recorded by these bits will persist until these bits are explicitly cleared. They are also cleared by powering down the chip.

ORL/ORR	Over/Under Range Detection
00	Less than -1 dB Underrange
01	Between -1 dB and 0 dB Underrange
10	Between 0 dB and 1 dB Overrange
11	Greater than 1 dB Overrange

- COR (RO) Capture Over Run. The codec sets (1) this bit when capture data is not read within one sample period after the capture FIFO fills. When COR is set, the FIFO is full and the codec discards any new data generated. The codec clears this bit immediately after a 4 byte capture sample is read.
- PUR (RO) Playback Under Run. The codec sets (1) this bit when playback data is not written within one sample period after the playback FIFO empties. The codec clears (0) this bit immediately after a 4 byte playback sample is written. When PUR is set, the playback channel has “run out” of data and either plays back a mid-scale value or repeats the last sample.

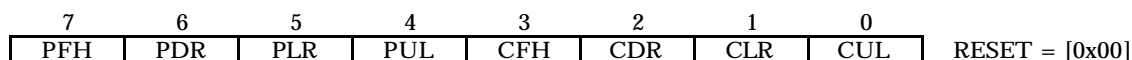
[Base+5] PIO Status

- CUL (RO) Capture Upper/Lower Sample. This bit indicates whether the PIO capture data ready is for the upper or lower byte of the channel.
 0 Lower byte ready
 1 Upper byte ready or any 8-bit mode
- CLR (RO) Capture Left/Right Sample. This bit indicates whether the PIO capture data waiting is for the left channel ADC or the right channel ADC.
 0 Right channel
 1 Left channel or mono

AD1817A

- CDR (RO) Capture Data Ready. The PIO Capture Data register contains data ready for reading by the host. This bit should be used only when direct programmed I/O data transfers are desired (FIFO has at least 4 bytes before full).
 0 ADC is stale. Do not reread the information
 1 ADC data is fresh. Ready for next host data read
- CFH (RO) Capture FIFO Half Full. (FIFO has at least 32 bytes before full.)
- PUL (RO) Playback Upper/Lower Sample. This bit indicates whether the PIO playback data needed is for the upper or lower byte of the channel.
 0 Lower byte needed
 1 Upper byte needed or any 8-bit mode
- PLR (RO) Playback Left/Right Sample. This bit indicates whether the PIO playback data needed is or the left channel DAC or the right channel DAC.
 0 Right channel needed
 1 Left channel or mono
- PDR (RO) Playback Data Ready. The PIO Playback data register is ready for more data. This bit should only be used when direct programmed I/O data transfers are desired (FIFO can take at least 4 bytes).
 0 DAC data is still valid. Do not overwrite
 1 DAC data is stale. Ready for next host data write value
- PFH (RO) Playback FIFO Half Empty. FIFO can take at least 32-bytes, 8 groups of 4-bytes.

[Base+6] PIO Data

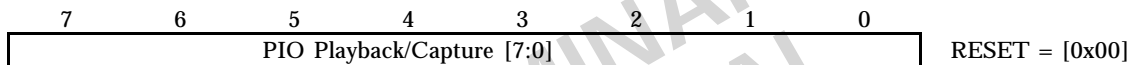

PIO Playback/
Capture [7:0]

The Programmed I/O (PIO) Data Registers for capture and playback are mapped to the same address. Writes send data to the Playback Register and reads will receive data from the Capture Register.

Reading this register will increment the capture byte state machine so that the following read will be from the next appropriate byte in the sample. The exact byte may be determined by reading the PIO Status Register. Once all relevant bytes have been read, the state machine will stay pointed to the last byte of the sample until a new sample is received.

Writing data to this register will increment the playback byte tracking state machine so that the following write will be to the correct byte of the sample. Once all bytes have been written, subsequent byte writes will be ignored. The state machine is reset when the current sample is transferred.

Note: All writes to the FIFO “MUST” contain 4 bytes of data.

- * 1 sample of 16-bit stereo
- * 2 samples of 16-bit mono
- * 2 samples of 8-bit stereo (Linear PCM, μ -law PCM, A-Law PCM)
- * 4 samples of 8-bit mono (Linear PCM, μ -law PCM, A-Law PCM)

[Base+7] Reserved

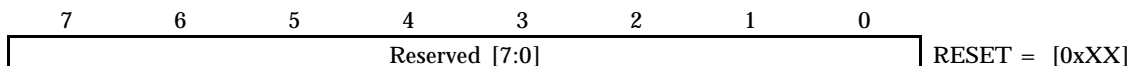

[Base+8] Playback Configuration

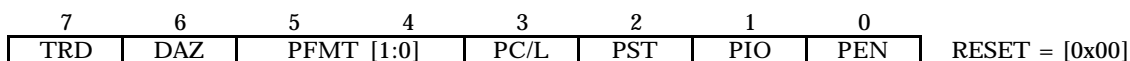

- PEN (RW) Playback Enable. This bit enables or disables programmed I/O data playback.
 0 Disable
 1 Enable
- PIO (RW) Programmed Input/Output. This bit determines whether the playback data is transferred via DMA or PIO.
 0 DMA transfers only
 1 PIO transfers only
- PST (RW) Playback Stereo/Mono select. These bits select stereo or mono formatting for the input audio data streams. In stereo, the Codec alternates samples between channels to provide left and right channel input. For mono, the Codec captures samples on the left channel stereo.
 0 Mono
 1 Stereo

PC/L	(RW)	Playback Companded/Linear Select. This bit selects between a linear digital representation of the audio signal or a nonlinear companded format for all output data. The type of linear PCM or the type of companded format is defined by PFMT [1:0]. 0 Linear PCM 1 Companded
PFMT [1:0]	(RW)	Playback Format. Use these bits to select the playback data format for output data according to Table VI and Figure 15.
DAZ	(RW)	DAC zero. This bit forces the DAC to zero. 0 Repeat last sample 1 Force DAC to Zero
TRD	(RW)	Transfer Request Disable. This bit enables or disables Codec DMA transfers during a Codec interrupt (indicated by the SS Codec Status register's INT bit being set [1]). This assumes Codec DMA transfers were enabled and the PEN or CEN bits are set. 0 Transfer Request Enable 1 Transfer Request Disable

After setting format bits, sample data into the AD1817A must be ordered according to Figure 7, Table V.

PRELIMINARY
TECHNICAL
DATA

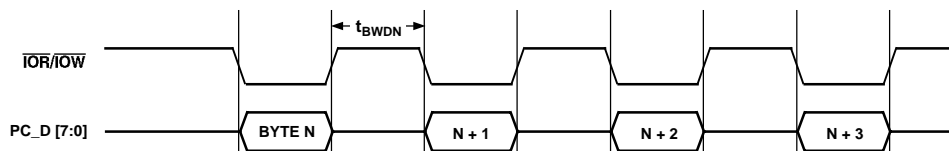

Figure 7. Codec Transfers

Table V. Codec Transfers

ST	FMT1 FMT0 C/L	Format	Byte 3		Byte 2		Byte 1		Byte 0	
			MSB	LSB	MSB	LSB	MSB	LSB	MSB	LSB
0	000	Mono Linear, 8-Bit Unsigned	Sample 3 8 Bits Left Channel	Sample 2 8 Bits Left Channel	Sample 1 8 Bits Left Channel	Sample 0 8 Bits Left Channel				
1	000	Stereo Linear, 8-Bit Unsigned	Sample 1 8 Bits Right Channel	Sample 1 8 Bits Left Channel	Sample 0 8 Bits Right Channel	Sample 0 8 Bits Left Channel				
0	001	Mono μ -Law, 8-Bit Companded	Sample 3 8 Bits Left Channel	Sample 2 8 Bits Left Channel	Sample 1 8 Bits Left Channel	Sample 0 8 Bits Left Channel				
1	001	Stereo μ -Law, 8-Bit Companded	Sample 1 8 Bits Right Channel	Sample 1 8 Bits Left Channel	Sample 0 8 Bits Right Channel	Sample 0 8 Bits Left Channel				
0	010	Mono Linear 16-Bit Little Endian	Sample 1 Upper 8 Bits Left Channel	Sample 1 Lower 8 Bits Left Channel	Sample 0 Upper 8 Bits Left Channel	Sample 0 Lower 8 Bits Left Channel				
1	010	Stereo Linear 16-Bit Little Endian	Sample 0 Upper 8 Bits Right Channel	Sample 0 Lower 8 Bits Right Channel	Sample 0 Upper 8 Bits Left Channel	Sample 0 Lower 8 Bits Left Channel				
0	011	Mono A-Law, 8-Bit Companded	Sample 3 8 Bits Left Channel	Sample 2 8 Bits Left Channel	Sample 1 8 Bits Left Channel	Sample 0 8 Bits Left Channel				
1	011	Stereo A-Law, 8-Bit Companded	Sample 1 8 Bits Right Channel	Sample 1 8 Bits Left Channel	Sample 0 8 Bits Right Channel	Sample 0 8 Bits Left Channel				
0	100	Reserved								
1	100	Reserved								
0	101	Reserved								
1	101	Reserved								
0	110	Mono Linear, 16-Bit Big Endian	Sample 1 Lower 8 Bits Left Channel	Sample 1 Upper 8 Bits Left Channel	Sample 0 Lower 8 Bits Left Channel	Sample 0 Upper 8 Bits Left Channel				
0	110	Stereo Linear, 16-Bit Big Endian	Sample 0 Lower 8 Bits Right+ Channel	Sample 0 Upper 8 Bits Left Channel	Sample 0 Lower 8 Bits Left Channel	Sample 0 Upper 8 Bits Left Channel				
0	111	Reserved								
1	111	Reserved								

[Base+9] Capture Configuration

7	6	5	4	3	2	1	0	
RES		CFMT [1:0]		CC/L	CST	CIO	CEN	RESET = [0x00]

- CEN (RW) Capture Enable. This bit enables or disables data capture.
 0 Disable
 1 Enable
- CIO (RW) Capture Programmed I/O. This bit determines whether the capture data is transferred via DMA or PIO.
 0 DMA
 1 PIO
- CST (RW) Capture Stereo/Mono Select. This bit selects stereo or mono formatting for the input audio data streams. In stereo, the Codec alternates samples between channels to provide left and right channel input. For mono, the Codec captures samples on the left channel.
 0 Mono
 1 Stereo
- CC/L (RW) Capture Companded/Linear Select. This bit selects between a linear digital representation of the audio signal or a nonlinear, companded format for all output data. The type of linear PCM or the type of companded format is defined by CFMT [1:0].
 0 Linear PCM
 1 Companded
- CFMT [1:0] (RW) Capture Format. Use these bits to select the format for capture data according to the following Table V and Figure 7.

[Base+10] ACPI Power-Down Control

7	6	5	4	3	2	1	0	
RES			ADDN	DPDN	SUSP	RD_MODE		RESET = [0xXX]

- RD_MODE Read Mode. Enables readback of Sound Blaster and OPL music synthesizer registers.
- SUSP Suspend. Setting this bit suspends Sound Blaster DMA transfer.
 0 Disable
 1 Enable
- DPDN Digital Power-Down. Powers-down digital interface functions and internal OPL music synthesizer. Analog mixers remain active.
- APDN Analog Power-Down. Powers-down all analog function. Digital interface remains active.

[Base+11] Reserved

7	6	5	4	3	2	1	0	
RESERVED								RESET = [0xXX]

[Base+13] Reserved

7	6	5	4	3	2	1	0	
RESERVED								RESET = [0xF0]

[Base+14] Reserved

7	6	5	4	3	2	1	0	
RESERVED								RESET = [0xFF]

JAXIS [7:0] (RO) Joystick Axis Low Byte.

Note: Axis to be read through this register is selected by the JSEL bits in the control register. A write to this register starts a sampling cycle.

[Base+15] Reserved

7	6	5	4	3	2	1	0	
RESERVED								RESET = [0xFF]

AD1817A

Sound System Indirect Registers

Writing Indirect Registers

All Indirect Registers “MUST” be written in pairs: low byte followed by high byte. The Indirect Address Register [SSBASE+0] holds the address for a register pair, the Indirect Low Data Byte [SSBASE+2] is used to write low data byte and the Indirect High Data Byte [SSBASE+3] is used to write the high data byte. The low data byte is held in the temporary register until the upper byte is written.

Programming Example

“Write Sample Rate for Voice Playback at 11,000 Hz (0x2AF8)”

- 1) Write [SSBASE+0] with 0x02 ; indirect register for voice playback sample rate
- 2) Write [SSBASE+2] with 0xF8 ; low byte of 16-bit sample rate register
- 3) Write [SSBASE+3] with 0x2A ; high byte of 16-bit sample rate register

Reading Indirect Registers

All indirect registers can be individually read. The Sound System Indirect Address Register [SSBASE+0] holds the address for a register pair, the Indirect Low Data Byte [SSBASE+2] is used to read low data byte and Indirect High Data Byte [SSBASE+3] is used to read the High data byte.

Programming Example

“Read Sample Rate for Voice Playback set to 11,000 Hz (0x2AF8)”

- 1) Write [SSBASE+0] with 0x02 ; indirect register for voice playback sample rate
- 2) Read [SSBASE+2] ; low byte of 16-bit sample rate register set to 0xF8
- 3) Read [SSBASE+3] ; high byte of 16-bit sample rate register set to 0x2A

ISR Saves and Restores

For Interrupt Service Routines, ISRs, it is necessary to save and restore the Indirect Address and the Low Byte Temporary Data holding registers inside the ISR.

Programming Example

“Save/Restore during an ISR”

Beginning of ISR:

- 1) Read [SSBASE+0] ; save Indirect Address register to TMP_IA
- 2) Write [SSBASE+0] with 0x00; ; indirect Register for Low Byte Temporary Data
- 3) Read [SSBASE+2] ; save Low Byte Temporary data to TMP_LBT
- 4) ISR Code ; ISR routine
- 5) Write [SSBASE+2] with TMP_LBT ; restore Low Byte Temporary data TMP_LBT
- 6) Write [SSBASE+0] with TMP_IA ; restore Indirect Address Register to TMP_IA
- 7) Return from Interrupt ; return from ISR

Table VI. Indirect Register Map and Reset/Default States

Address	Register Name	Reset/ Default State
00	Low Byte TMP	0xXX
01	Interrupt Enable and External Control	0x0102
02	Voice Playback Sample Rate	0x1F40
03	Voice Capture Sample Rate	0x1F40
04	Voice Attenuation	0x8080
05	FM Attenuation	0xFFFF
06	Reserved	0xFFFF
07	Reserved	0x8080
08	Playback Base Count	0x0000
09	Playback Current Count	0x0000
10	Capture Base Count	0x0000
11	Capture Current Count	0x0000
12	Timer Base Count	0x0000
13	Timer Current Count	0x0000
14	Master Volume Attenuation	0x8888
15	CD Gain/Attenuation	0x8888
16	Synth Gain/Attenuation	0x8888
17	Reserved	0xFFFF
18	Reserved	0x8888
19	Mic Gain/Attenuation	0xC888
20	ADC Source Select and ADC PGA	0x0000
32	Chip Configuration	0x00F0
33	Reserved	0xFFFF
34	Reserved	0xFFFF
35	Reserved	0xFFFF
36	Reserved	0xFFFF
37	Reserved	0x0000
38	Reserved	0xAC44
39	PHONE_OUT Gain Attenuation	0x8000
40	Reserved	0x0000
41	Hardware Volume Button Modifier	0XX1B
42	Reserved	0x0000
43	Reserved	0x0000
44	Power_Down and Timer Control	0x0000
45	Version ID	0x0000
46	Reserved	0x0000

Table VII. Sound System Indirect Registers

ADDRESS	(High Byte)								(Low Byte)									
	7	6	5	4	3	2	1	0	7	6	5	4	3	2	1	0		
00 (0x00)	RES								LBTD [7:0]									
01 (0x01)	PIE	CIE	TIE	VIE	RES	RIE	RES	SIE	RES								XC1	XC0
02 (0x02)	VPSR [15:8]								VPSR [7:0]									
03 (0x03)	VCSR [15:8]								VCSR [7:0]									
04 (0x04)	LVM	RES	LVA [5:0]					RVM	RES	RVA [5:0]								
05 (0x05)	LFMM	RES	LFMA [5:0]					RFMM	RES	RFMA [5:0]								
06 (0x06)	RES								RES									
07 (0x07)	LSOM	RES	LSOA [5:0]					RSOM	RES	RSOA [5:0]								
08 (0x08)	PBC [15:8]								PBC [7:0]									
09 (0x09)	PCC [15:8]								PCC [7:0]									
10 (0x0A)	CBC [15:8]								CBC [7:0]									
11 (0x0B)	CCC [15:8]								CCC [7:0]									
12 (0x0C)	TBC [15:8]								TBC [7:0]									
13 (0x0D)	TCC [15:8]								TCC [7:0]									
14 (0x0E)	LMVM	RES	LMVA [4:0]					RMVM	RES	RMVA [4:0]								
15 (0x0F)	LCDM	RES	LCDA [4:0]					RCDM	RES	RCDA [4:0]								
16 (0x10)	LSYM	RES	LSYA [4:0]					RSYM	RES	RSYA [4:0]								
17 (0x11)	LVDM	RES	LVDA [4:0]					RVDM	RES	RVDA [4:0]								
18 (0x12)	RES								RES									
19 (0x13)	MCM	M20	RES	MCA [4:0]					PIM	RES	PIA [3:0]					RES		
20 (0x14)	LAGC	LAS [2:0]			LAG [3:0]					RAGC	RAS [2:0]			RAG [3:0]				
32 (0x20)	WSE	CDE	RES	CNP	RES													
33 (0x21)	RES								RES									
34 (0x22)	RES								RES									
35 (0x23)	RES								RES									
36 (0x24)	RES								RES									
37 (0x25)	RES								RES									
38 (0x26)	RES								RES									
39 (0x27)	RES								POM	RES	POA [4:0]							
40 (0x28)	RES								RES									
41 (0x29)	HVM	INSEL	HVMAS	HVATN [4:0]					VMU	VUP	VDN	BM [4:0]						
42 (0x2A)	RES								RES									
43 (0x2B)	RES								RES									
44 (0x2C)	CPD	RES	PIW	PIR	PAA	PDA	PDP	PTB	3D	PD3D	GPSP	RES						
45 (0x2D)	VER [15:8]								VER [7:0]									
46 (0x2E)	RES								RES									

[00] INDIRECT LOW BYTE TMP

DEFAULT = [0xXX]

7	6	5	4	3	2	1	0	7	6	5	4	3	2	1	0
RES								LBTD [7:0]							

LBTD [7:0] Low Byte Temporary Data holding latch for register pair writes;
 Written on any write to [SSBase + 2],
 Read from [SSBase + 2] when the indirect address is 0x00.

[01] INTERRUPT ENABLE AND EXTERNAL CONTROL

DEFAULT = [0x0102]

7	6	5	4	3	2	1	0	7	6	5	4	3	2	1	0		
PIE	CIE	TIE	VIE	RES	RIE	RES	SIE	RES								XC1	XC0

- XC0 RW External Control 0. The state of this bit is reflected on the XCTL0 pin. This pin is also muxed with PCLKO. COF must be greater than 11 for PCLKO to be disabled, see SS [32].
- XC1 RW External Control 1. The state of this bit is reflected on the XCTL1 pin. XCTL1 may also be used for Ring-In Interrupt.
- SIE RW SoundBlaster Interrupt Enable;
 0 SoundBlaster Interrupt disabled
 1 SoundBlaster Interrupt enabled
- RIE RW Ring Interrupt Enable;
 0 Ring Interrupt disabled
 1 Ring Interrupt enabled
- VIE RW Volume Interrupt Enable. If enabled, software increments/decrements BUTTON MODIFIER via interrupt routine and pushing buttons only sets VUP, VDN, VMU bits. It does not change the volume.
 0 Volume Interrupt disabled
 1 Volume Interrupt enabled

TIE	RW	Timer Interrupt Enable; 0 Timer Interrupt disabled 1 Timer Interrupt enabled
CIE	RW	Capture Interrupt Enable; 0 Capture Interrupt disabled 1 Capture Interrupt enabled
PIE	RW	Playback Interrupt Enable; 0 Playback Interrupt disabled 1 Playback Interrupt enabled

[02] VOICE PLAYBACK SAMPLE RATE**DEFAULT = [0x1F40]**

7	6	5	4	3	2	1	0	7	6	5	4	3	2	1
VPSR [15:8]								VPSR [7:0]						

VPSR [15:0] Voice Playback Sample Rate. The sample rate can be programmed from 4 kHz to 55.2 kHz in 1 hertz increments. The default playback sample rate is 8 kHz.

[03] VOICE CAPTURE SAMPLE RATE**DEFAULT = [0x1F40]**

7	6	5	4	3	2	1	0	7	6	5	4	3	2	1	0
VCSR [15:8]								VCSR [7:0]							

VCSR [15:0] Voice Capture Sample Rate. The sample rate can be programmed from 4 kHz to 55.2 kHz in 1 hertz increments. Ignored if CNP bit in SS [32] = 0 in which case VPSR [15:0] controls capture rate. The default capture sample rate is 8 kHz.

[04] VOICE ATTENUATION**DEFAULT = [0x8080]**

7	6	5	4	3	2	1	0	7	6	5	4	3	2	1	0
LVM	RES	LVA [5:0]						RVM	RES	RVA [5:0]					

RVA [5:0] Right Voice Attenuation for Playback channel. The LSB represents -1.5 dB, 000000 = 0 dB and the range is 0 dB to -94.5 dB.

RVM Right Voice Mute. 0 = Unmuted, 1 = Muted.

LVA [5:0] Left Voice Attenuation for Playback channel. The LSB represents -1.5 dB, 000000 = 0 dB and the range is 0 dB to -94.5 dB.

LVM Left Voice Mute. 0 = Unmuted, 1 = Muted.

[05] FM ATTENUATION**DEFAULT = [0x8080]**

7	6	5	4	3	2	1	0	7	6	5	4	3	2	1	0
LFMM	RES	LFMA [5:0]						RFMM	RES	RFMA [5:0]					

RFMA [5:0] Right F Music Attenuation for the internal Music Synthesizer. The LSB represents -1.5 dB, 000000 = 0 dB and the range is 0 dB to -94.5 dB.

RFMM Right F Music Mute. 0 = Unmuted, 1 = Muted.

LFMA [5:0] Left F Music Attenuation for the internal Music Synthesizer. The LSB represents -1.5 dB, 000000 = 0 dB and the range is 0 dB to -94.5 dB.

LFMM Left F Music Mute. 0 = Unmuted, 1 = Muted.

[06] RESERVED**DEFAULT = [0xXXXX]**

7	6	5	4	3	2	1	0	7	6	5	4	3	2	1	0
RES								RES							

[07] RESERVED**DEFAULT = [0xXXXX]**

7	6	5	4	3	2	1	0	7	6	5	4	3	2	1	0
RES								RES							

AD1817A

[08] PLAYBACK BASE COUNT **DEFAULT = [0x0000]**

	7	6	5	4	3	2	1	0		7	6	5	4	3	2	1	0
PBC [15:8]									PBC [7:0]								

PBC [15:0] Playback Base Count. This register is for loading the Playback DMA Count. Writing a value to this register also loads the same data into the Playback Current Count register. You must load this register when Playback Enable (PEN) is deasserted. When PEN is asserted, the Playback Current Count decrements once for every four bytes transferred via a DMA cycle. The next transfer, after zero is reached in the Playback Current Count, will generate an interrupt and reload the Playback Current Count with the value in the Playback Base Count. The Playback Base Count should always be programmed to Number Bytes divided by four, minus one ((Number Bytes/4) -1). The circular software DMA buffer must be divisible by four to ensure proper operation.

[09] PLAYBACK CURRENT COUNT **DEFAULT = [0x0000]**

	7	6	5	4	3	2	1	0		7	6	5	4	3	2	1	0
PCC [15:8]									PCC [7:0]								

PCC [15:0] Playback Current Count register. Contains the current Playback DMA Count. Reads and Writes must be done when PEN is deasserted.

[10] CAPTURE BASE COUNT **DEFAULT = [0x0000]**

	7	6	5	4	3	2	1	0		7	6	5	4	3	2	1	0
CBC [15:8]									CBC [7:0]								

CBC [15:0] Capture Base Count. This register is for loading the Capture DMA Count. Writing a value to this register also loads the same data into the Capture Current Count register. Loading must be done when Capture Enable (CEN) is deasserted. When CEN is asserted, the Capture Current Count decrements once for every four bytes transferred via a DMA cycle. The next transfer, after zero is reached in the Capture Current Count, will generate an interrupt and reload the Capture Current Count with the value in the Capture Base Count. The Capture Base Count should always be programmed to Number Bytes divided by four, minus one ((Number Bytes/4) -1). The circular software DMA buffer must be divisible by four to ensure proper operation.

[11] CAPTURE CURRENT COUNT **DEFAULT = [0x0000]**

	7	6	5	4	3	2	1	0		7	6	5	4	3	2	1	0
CCC [15:8]									CCC [7:0]								

CCC [15:0] Capture Current Count register. Contains the current Capture DMA Count. Reading and Writing must be done when CEN is deasserted.

[12] TIMER BASE COUNT **DEFAULT = [0x0000]**

	7	6	5	4	3	2	1	0		7	6	5	4	3	2	1	0
TBC [15:8]									TBC [7:0]								

TBC [15:0] Timer Base Count. Register for loading the Timer Count. Writing a value to this register also loads the same data into the Timer Current Count register. Loading must be done when Timer Enable (TE) is deasserted. When TE is asserted, the Timer Current Count register decrements once for every specified time period. The time period (10 μ s or 100 ms) is programmed via the PTB bit in SS [44]. When TE is asserted, the Timer Current Count decrements once every time period. The next count, after zero is reached in the Timer Current Count register, will generate an interrupt and reload the Timer Current Count register with the value in the Timer Current Count register.

[13] TIMER CURRENT COUNT **DEFAULT = [0x0000]**

	7	6	5	4	3	2	1	0		7	6	5	4	3	2	1	0
TCC [15:8]									TCC [7:0]								

TCC [15:0] Timer DMA Current Count register. Contains the current timer count. Reading and Writing must be done when TE is deasserted.

[14] MASTER VOLUME ATTENUATION **DEFAULT = [0x8888]**

	7	6	5	4	3	2	1	0		7	6	5	4	3	2	1	0
LMVM	RES		LMVA [4:0]						RMVM	RES		RMVA [4:0]					

RMVA [4:0] Right Master Volume Attenuation. The LSB represents -1.5 dB, 00000 = 0 dB and the range is 0 dB to -46.5 dB. This register is added with the Hardware Volume Button Modifier value to produce the final DAC Master Volume attenuation level. See Hardware Volume Button Modifier Register description for more details.

RMVM Right Master Volume Mute. 0 = Unmuted, 1 = Muted.

LMVA [4:0] Left Master Volume Attenuation. The LSB represents -1.5 dB, 00000 = 0 dB and the range is 0 dB to -46.5 dB. This register is added with the Hardware Volume Button Modifier value to produce the final DAC Master Volume attenuation level. See Hardware Volume Button Modifier Register description for more details.

LMVM Left Master Volume Mute. 0 = Unmuted, 1 = Muted.

[15] CD GAIN/ATTENUATION**DEFAULT = [0x8888]**

7	6	5	4	3	2	1	0	7	6	5	4	3	2	1	0
LCDM	RES	LCDA [4:0]						RCDM	RES	RCDA [4:0]					

RCDA [4:0] Right CD Attenuation. The LSB represents -1.5 dB, 00000 = +12 dB and the range is +12 dB to -34.5 dB.

RCDM Right CD Mute. 0 = Unmuted, 1 = Muted.

LCDA [4:0] Left CD Attenuation. The LSB represents -1.5 dB, 00000 = +12 dB and the range is +12 dB to -34.5 dB.

LCDM Left CD Mute. 0 = Unmuted, 1 = Muted.

[16] SYNTH GAIN/ATTENUATION**DEFAULT = [0x8888]**

7	6	5	4	3	2	1	0	7	6	5	4	3	2	1	0
LSYM	RES	LSYA [4:0]						RSYM	RES	RSYA [4:0]					

RSYA [4:0] Right SYNTH Attenuation. The LSB represents -1.5 dB, 00000 = +12 dB and the range is +12 dB to -34.5 dB.

RSYM Right SYNTH Mute. 0 = Unmuted, 1 = Muted.

LSYA [4:0] Left SYNTH Attenuation. The LSB represents -1.5 dB, 00000 = +12 dB and the range is +12 dB to -34.5 dB.

LSYM Left SYNTH Mute. 0 = Unmuted, 1 = Muted.

[17] RESERVED**DEFAULT = [0XXXXX]**

7	6	5	4	3	2	1	0	7	6	5	4	3	2	1	0
RESERVED								RESERVED							

[18] RESERVED**DEFAULT = [0x8888]**

7	6	5	4	3	2	1	0	7	6	5	4	3	2	1	0
RES								RES							

[19] MIC/PHONE_IN GAIN/ATTENUATION**DEFAULT = [0xC888]**

7	6	5	4	3	2	1	0	7	6	5	4	3	2	1	0
MCM	M20	RES	MCA [4:0]					PIM	RES	PIA [3:0]			RES		

PIA [3:0] PHONE_IN Attenuation. The LSB represents -3 dB, 0000 = 0 dB and the range is 0 dB to -45 dB.

PIM PHONE_IN Mute.

MCA [4:0] Microphone Attenuation. The LSB represents -1.5 dB, 00000 = +12 dB and the range is ±12 dB to -34.5 dB.

M20 Microphone 20 dB Gain. The M20-bit enables the Microphone +20 dB gain stage.

MCM Microphone Mute.

[20] ADC SOURCE SELECT AND ADC PGA**DEFAULT = [0x0000]**

7	6	5	4	3	2	1	0	7	6	5	4	3	2	1	0
LAGC	LAS [2:0]		LAG [3:0]			RAGC	RAS [2:0]		RAG [3:0]						

RAG [3:0] Right ADC Gain Control ADC source select and Gain. For Gain, LSB represents +1.5 dB, 0000 = 0 dB and the range is 0 dB to +22.5 dB.

RAGC Right Automatic Gain Control (AGC) Enable, 0 = Enabled, 1 = Disabled.

LAG [3:0] Left ADC Gain Control ADC source select and Gain. For Gain, LSB represents +1.5 dB, 0000 = 0 dB and the range is 0 dB to +22.5 dB.

AD1817A

LAGC Left Automatic Gain Control (AGC) Enable, 0 = Enabled, 1 = Disabled.

RAS [2:0]	ADC Right Input Source	LAS [2:0]	ADC Left Input Source
000	R_LINE	000	L_LINE
001	R_OUT	001	L_OUT
010	R_CD	010	L_CD
011	R_SYNTH	011	L_SYNTH
101	Mono Mix	101	MIC
110	Reserved	110	PHONE_IN
111	Reserved	111	Reserved

[32] CHIP CONFIGURATION **DEFAULT = [0x00F0]**

7	6	5	4	3	2	1	0	7	6	5	4	3	2	1	0
WSE CDE RES CNP RES								RES							

CNP Capture not equal to Playback.
 0 = Capture equals Playback. The capture sample rate is determined by the playback sample rate in SS [02].
 1 = Capture not equal to Playback.

WSE Sound System Enable.
 0 = SoundBlaster Mode.
 1 = Sound System Mode under Windows.

Note: When in SoundBlaster Mode, the Codec ADC and DAC channels will be used solely for converting SoundBlaster data.

[33] RESERVED **DEFAULT = [0x0000]**

7	6	5	4	3	2	1	0	7	6	5	4	3	2	1	0
RES								RES							

[34] RESERVED **DEFAULT = [0xXXXX]**

7	6	5	4	3	2	1	0	7	6	5	4	3	2	1	0
RES								RES							

[35] RESERVED **DEFAULT = [0xXXXX]**

7	6	5	4	3	2	1	0	7	6	5	4	3	2	1	0
RES								RES							

[36] RESERVED **DEFAULT = [0xXXXX]**

7	6	5	4	3	2	1	0	7	6	5	4	3	2	1	0
RES								RES							

[37] RESERVED **DEFAULT = 0x0000**

7	6	5	4	3	2	1	0	7	6	5	4	3	2	1	0
RES								RES							

[38] RESERVED **DEFAULT = [0xAC44]**

7	6	5	4	3	2	1	0	7	6	5	4	3	2	1	0
RES								RES							

[39] PHONE_OUT Attenuation **DEFAULT = [0x8000]**

7	6	5	4	3	2	1	0	7	6	5	4	3	2	1	0	
RES	RES							RES	POM	RES	POA [4:0]					

POA [4:0] PHONE_OUT Attenuation. The LSB represents -1.5 dB, 0000 = 0 dB and the range is 0 dB to -46.5 dB.

POM PHONE_OUT Mute. 0 = Unmuted, 1 = Muted.

[40] RESERVED **DEFAULT = 0x0000**

7	6	5	4	3	2	1	0	7	6	5	4	3	2	1	0
RES								RES							

[41] HARDWARE VOLUME BUTTON MODIFIER **DEFAULT = [0xXX1B]**

7	6	5	4	3	2	1	0	7	6	5	4	3	2	1	0	
HVM	HVSEL	HVMAS	HVATN [4:0]					VMU	VUP	VDN	BM [4:0]					

BM [4:0] Button Modifier

VDM	Volume Down
VUP	Volume Up
VMU	Volume Mute
HVATN [4:0]	Hardware Volume Attenuation
HVMAS	Hardware Volume Master Mode
HVSEL	Hardware Volume Select
HVM	Hardware Volume Mute

This register contains a Master Volume attenuation offset, which can be incremented or decremented via the Hardware Volume Pins. This register is summed with the Master Volume attenuation to produce the actual Master Volume DAC attenuation. A momentary grounding of greater than 50 ms on the VOL_UP pin will cause a decrement (decrease in Attenuation) in this register. Holding the pin LO for greater than 200 ms will cause an auto-decrement every 200 ms. This is also true for a momentary grounding of the VOL_DN pin. A momentary grounding of both the VOL_UP and VOL_DN causes a mute and no increment or decrement to occur.

When Muted, an unmute is possible by a momentary grounding of both the VOL_UP and VOL_DN pins together, a momentary grounding of VOL_UP (this also causes a volume increase), a momentary grounding of VOL_DN (this also causes a volume decrease) or a write of "0" to the VI bit in SS [BASE+1].

[42] RESERVED **DEFAULT = [0x0000]**

7	6	5	4	3	2	1	0	7	6	5	4	3	2	1	0
RES								RES							

[43] RESERVED **DEFAULT = [0x0000]**

7	6	5	4	3	2	1	0	7	6	5	4	3	2	1	0
RES								RES							

[44] POWER-DOWN AND TIMER CONTROL **DEFAULT = [0x0000]**

7	6	5	4	3	2	1	0	7	6	5	4	3	2	1	0
CPD	RES	PIW	PIR	PAA	PDA	RES	PTB	GPSP				RES			

The AD1817A supports a timeout mechanism used in conjunction with the Timer Base Count and Timer Current Count registers to generate a power-down interrupt. This interrupt allows software to power down the entire chip by setting the CPD bit. This power-down control feature lets users program a time interval from 1 ms to approximately 1.8 hours in 1 ms increments. Five power-down count reload enable bits are used to reload the Timer Current Count from the Timer Base Count when activity is seen on that particular channel.

Programming Example: Generate Interrupt if No ISA Reads or Writes occur within 15 Minutes.

- 1) Write [SSBASE+0] with 0x0C ; Write Indirect address for TIMER BASE COUNT "register 12"
- 2) Write [SSBASE+2] with 0x28 ; Write TIMER BASE COUNT with (15 min × 60 sec/min × 10) = 0x2328 milli-Seconds
- 3) Write [SSBASE+3] with 0x23 ; Write High byte of TIMER BASE COUNT
- 4) Write [SSBASE+0] with 0x2C ; Write Indirect address for POWER-DOWN and TIMER CONTROL register
- 5) Write [SSBASE+2] with 0x00 ; Write Low byte of POWER-DOWN and TIMER CONTROL register
- 6) Write [SSBASE+3] with 0x30 ; Set Enable bits for PIW & PIR
- 7) Write [SSBASE+0] with 0x01 ; Write Indirect address for INTERRUPT CONFIG register
- 8) Write [SSBASE+2] with 0x82 ; Set the TE (Timer Enable) bit
- 9) Write [SSBASE+3] with 0x20 ; Set the TIE (Timer Interrupt Enable) bit

GPSP	Game Port Speed Select. Selects the operating speed of the game port.
0	Slow Game Port
1	Fast Game Port

AD1817A

- PTB Power-Down Time Base. 1 = timer set to 100 ms, 0 = timer set to 10 μ s.
- PDA Power-down count reload on Digital Activity; "1" = Reload count on Digital Activity. Digital Activity is defined as any activity on FM or PLAYBACK).
- PAA Power-down count reload on Analog Activity; "1" = Reload count on Analog Activity. Analog Activity is defined as any analog input unmuted (LINE, CD, SYNTH, MIC, PHONE_IN) or MASTER VOLUME unmuting.
- PIR Power-down count reload on ISA Read; "1" = Reload count on ISA read. ISA Read is defined as a read from any active logical device inside the AD1817A.
- PIW Power-down count reload on ISA Write; "1" = Reload count on ISA write. ISA Write defined as a write to any active logical device inside the AD1817A.
- CPD Chip Power-down
 - 1 Power-Down;
 - 0 Power-Up

For Power-up, software should poll the [SSBASE+0] CRY bit for "1" before writing or reading any logical device.

[45] VERSION ID										DEFAULT = [0x0000]					
7	6	5	4	3	2	1	0	7	6	5	4	3	2	1	0
VER [15:8]								VER [7:0]							
[46] RESERVED										DEFAULT = [0x0000]					
7	6	5	4	3	2	1	0	7	6	5	4	3	2	1	0
RES								RES							

Test register. Should never be written or read under normal operation.

SB Pro; AdLib Registers

The AD1817A contains sets of ISA Bus registers (ports) that correspond to those used by the SoundBlaster Pro audio card from Creative Labs and the AdLib audio card from AdLib Multimedia. Table IX lists the ISA Bus SoundBlaster Pro registers. Table X lists the ISA Bus AdLib registers. Because the AdLib registers are a subset of those in the SoundBlaster card, you can find complete information on using both of these registers in the *Developer Kit for SoundBlaster Series, 2nd ed.* © 1993, Creative Labs, Inc., 1901 McCarthy Blvd., Milpitas, CA 95035.

Table VIII. SoundBlaster Pro ISA Bus Registers

Register Name	ISA Bus Address
Music0: Address (w), Status (r)	0x(SB Base) Relocatable in range 0x010 - 0x3F0
Music0: Data (w)	0x(SB Base+1)
Music1: Address (w)	0x(SB Base+2)
Music1: Data (w)	0x(SB Base+3)
Mixer Address (w)	0x(SB Base+4)
Mixer Data (w)	0x(SB Base+5)
Reset (w)	0x(SB Base+6)
Music0: Address (w)	0x(SB Base+8)
Music0: Data (w)	0x(SB Base+9)
Input Data (r)	0x(SB Base+A)
Status (r), Output Data (w)	0x(SB Base+C)
Status (r)	0x(SB Base+E)

Table IX. AdLib ISA Bus Registers

Register Name	ISA Bus Address
Music0: Address (w), Status (r)	0x(AdLib Base) Relocatable in range 0x008 - 0x3F8
Music0: Data (w)	0x(AdLib Base+1)
Music1: Address (w)	0x(AdLib Base+2)
Music1: Data (w)	0x(AdLib Base+3)

MIDI and MPU-401 Registers

The AD1817A contains a set of ISA Bus registers (ports) that correspond to those used by the ISA bus MIDI audio interface cards. Table XI lists the ISA Bus MIDI registers. These registers support commands and data transfers described in *MIDI 1.0 Detailed Specification and Standard MIDI Files 1.0*, © 1994, MIDI Manufacturers Association, PO Box 3173 La Habra, CA 90632-3173.

Table X. MIDI ISA Bus Registers

Register Name	Address
MIDI Data (r/w)	0x(MIDI Base) Relocatable in range 0x008 to 0x3F8
MIDI Status (r), Command (w)	0x(MIDI Base+1)

0x(MIDI Base+1)

BIT	7	6	5	4	3	2	1	0
STATE	1	0	0	0	0	0	0	0
NAME	DRR	DSR	RESERVED					

- DSR (R) Data Send Ready. When read, this bit indicates that you can (0) or cannot (1) write to the MIDI Data register. (Full = 1, Empty = 0)
- DRR (R) Data Receive Ready. When read, this bit indicates that you can (0) or cannot (1) read from the MIDI Data register. (Unreadable = 1, Readable = 0)
- CMD [7:0] (W) MIDI Command. Write MPU-401 commands to bits [7:0] of this register.

NOTES

The AD1817A supports *only* the MIDI 0xFF (reset) and 0x3F (pass-through mode) commands. The controller powers setup for intelligent MIDI mode, but must be put in pass-through mode. To start MIDI operations, send a reset command (0xFF) and then send a pass-through mode command (0x3F). The MIDI data register contains an acknowledge byte (0xFE) after each command transfer.

All commands return an ACK byte in “smart” mode.

Status commands (0xAx) return ACK and a data byte; all other commands return ACK.

All commands except reset (0xFF) are ignored in UART mode. No ACK bytes are returned.

“Smart” mode data transfers are not supported.

Game Port Registers

The AD1817A contains a Game Port ISA Bus Register that corresponds to the game port described in the PnP specification.

Table XI. Game Port ISA Bus Registers

Register Name	Address
Game Port I/O	0x(Game Port Base+0 to Game Port Base+7) Relocatable in the range 0x100 to 0x3F8

APPENDIX A

PLUG AND PLAY INTERNAL ROM

Vendor ID: ADS7181
 Serial Number: FFFFFFFF
 Checksum: 2F
 PNP Version: 1.0, vendor version: 20
 ASCII string: "Analog Devices AD1817A"
 Logical Device ID: ADS7180
 not a boot device, implements PNP register(s) 31
 Start dependent function, best config
 IRQ: channel(s) 5 7
 type(s) active-high, edge-triggered
 DMA: channel(s) 1
 Type F, count-by-byte, nonbus-mastering, 8-bit only
 DMA: channel(s) 0 1 3
 Type F, count-by-byte, nonbus-mastering, 8-bit only
 I/O: 16-bit decode, range [0220,0240] mod 20, length 10
 I/O: 16-bit decode, range [0388,0388] mod 08, length 04
 I/O: 16-bit decode, range [0500,0560] mod 10, length 10
 Start dependent function, acceptable config
 IRQ: channel(s) 5 7 10
 type(s) active-high, edge-triggered
 DMA: channel(s) 0 1 3
 Type F, count-by-byte, nonbus-mastering, 8-bit only
 DMA: channel(s) 0 1 3
 Type F, count-by-byte, nonbus-mastering, 8-bit only
 I/O: 16-bit decode, range [0220,0240] mod 20, length 10
 I/O: 16-bit decode, range [0388,0388] mod 08, length 04
 I/O: 16-bit decode, range [0500,0560] mod 10, length 10
 Start dependent function, acceptable config
 IRQ: channel(s) 5 7 9 10 11 15
 type(s) active-high, edge-triggered
 DMA: channel(s) 0 1 3
 Type F, count-by-byte, nonbus-mastering, 8-bit only
 DMA: channel(s) 0 1 3
 Type F, count-by-byte, nonbus-mastering, 8-bit only
 I/O: 16-bit decode, range [0220,02E0] mod 20, length 10
 I/O: 16-bit decode, range [0388,03B8] mod 08, length 04
 I/O: 16-bit decode, range [0500,0560] mod 10, length 10

Start dependent function, suboptimal config
 IRQ: channel(s) 5 7 9 10 11 15
 type(s) active-high, edge-triggered
 DMA: channel(s) 0 1 3
 Type F, count-by-byte, nonbus-mastering, 8-bit only
 DMA: NULL
 I/O: 16-bit decode, range [0220,02E0] mod 20, length 10
 I/O: 16-bit decode, range [0388,03B8] mod 08, length 04
 I/O: 16-bit decode, range [0500,0560] mod 10, length 10
 End all dependent functions
 Logical Device ID: ADS7181
 not a boot device, implements PNP register(s) 31
 Compatible Device ID: PNPB006
 Start dependent function, best config
 IRQ: channel(s) 5 7 9 11
 type(s) active-high, edge-triggered
 I/O: 16-bit decode, range [0300,0330] mod 30, length 02
 Start dependent function, acceptable config
 IRQ: channel(s) 5 7 9 10 11 15
 type(s) active-high, edge-triggered
 I/O: 16-bit decode, range [0300,0420] mod 30, length 02
 End all dependent functions
 Logical Device ID: ADS7182
 not a boot device, implements PNP register(s) 31
 Compatible Device ID: PNPB02F
 Start dependent function, best config
 I/O: 16-bit decode, range [0200,0200] mod 08, length 08
 Start dependent function, acceptable config
 I/O: 16-bit decode, range [0200,0208] mod 08, length 08
 End all dependent functions
 End:

PLUG AND PLAY KEY AND “ALTERNATE KEY” SEQUENCES

One additional feature of the AD1817A is an alternate programming method used, for example, if a BIOS wants to assume control of the AD1817A and present DEVNODES to the OS (rather than having the device participate in Plug and Play enumeration). The following technique may be used.

Instead of the normal 32 byte Plug and Play key sequence, an alternate 126 byte key is used. After the 126 byte key, the AD1817A device will transition to the Plug and Play “config” state. It can then be programmed as usual using the standard Plug and Play ports. After programming, the AD1817A should be sent to the Plug and Play “WFK” (wait for key) state. Once the AD1817A has seen the alternate key, it will no longer parse for the Plug and Play key (and therefore never participate in Plug and Play enumeration). It can be reprogrammed by reissuing the alternate key again.

Both the Plug and Play key and the alternate key are sequences of writes to the Plug and Play address register, 0x279. Below are the ISA data values of both keys.

This is the standard Plug and Play sequence:

6a	b5	da	ed	f6	fb	7d	be	df	6f	37	1b	0d	86	c3	61
b0	58	2c	16	8b	45	a2	d1	e8	74	3a	9d	ce	e7	73	39

This is the longer, 126-byte alternate key. It is generated by the function:

$$f[n+1] = (f[n] \gg 1) | (((f[n] \wedge (f[n] \gg 1)) \& 0x01) \ll 6) \quad f[0] = 0x01$$

01	40	20	10	08	04	02	41	60	30	18	0c	06	43	21	50
28	14	0a	45	62	71	78	3c	1e	4f	27	13	09	44	22	51
68	34	1a	4d	66	73	39	5c	2e	57	2b	15	4a	65	72	79
7c	3e	5f	2f	17	0b	05	42	61	70	38	1c	0e	47	23	11
48	24	12	49	64	32	59	6c	36	5b	2d	56	6b	35	5a	6d
76	7b	3d	5e	6f	37	1b	0d	46	63	31	58	2c	16	4b	25
52	69	74	3a	5d	6e	77	3b	1d	4e	67	33	19	4c	26	53
29	54	2a	55	6a	75	7a	7d	7e	7f	3f	1f	0f	07		

PRELIMINARY
TECHNICAL
DATA

AD1817A

USING AN EEPROM WITH THE AD1817A

The AD1817A supports an optional Plug and Play resource ROM. If present, the ROM must be a two-wire serial device (e.g., Xicor X24C02) and the clock and data lines should be wired to EE_CLK and EE_DATA pins; pull-up resistors are required on both signals. The EEPROM's A2 and A1 pins (also A0 for 256-byte EEPROMs) must all be tied to ground. The write control pin (WC*) must be tied to power if you wish to program the EEPROM in place; otherwise, we recommend tying it to ground to prevent accidental writes.

The EEPROM interface logic examines the state of the EE_CLK pin shortly after RESET is deasserted and whenever the Plug and Play reset register (02h) is written with a value X such that $(X \& 4) \neq 0$. If EE_CLK is pulled high, the EEPROM logic attempts to read the first ROM byte (page 0, byte 0). If EE_CLK is tied low, the internal ROM is used; in this case EE_DATA is used to set the state of VOL_EN, and should also be tied high or low. EE_CLK is not used as an input at any other time.

The initial part of the ROM is not part of the Plug and Play resource data. It consists of a number of flags that enable optional functionality. The number of flag bytes and the purpose of each bit depend on whether an AD1817 or an AD1817A is being used.

AD1817A FLAG BYTES

The AD1817A has four flag bytes that are used as shown below:

(*) AD1817-compatible setting.

Byte 0

7	6	5	4	3	2	1	0
1	0	0	XTRA_HV	RES	SUPER_EN	XTRA_EN	MODEM_EN

MODEM_EN Program to one to enable the modem logical device. This logical device has an I/O range and an IRQ. The I/O range has the following requirements:

- Length of 8 bytes
- Alignment of 8 bytes
- 16-bit address decode

Program to zero to enable I²S Port 1 (SUPER_EN and IRQ_EN must also be zero).

XTRA_EN Program to one to enable the XTRA logical device. This logical device has an I/O range, an optional IRQ, and an optional DMA. The I/O range has the following requirements:

- Length of 1 to 16 bytes, selectable by XTRASZ0[3:0]
- Alignment of 1 to 16 bytes, matches length
- 16-bit address decode

A second I/O range is available, (see XTRA_CS). Program to zero to enable the DSP serial port (XTRA_HV must also be zero).

SUPER_EN Program to one to merge the XTRA and modem logical devices. If this bit is set to one, XTRA_EN and IRQ_EN must be set to one and MODEM_EN must be set to zero. The combined device has up to two I/O ranges, two IRQs and one DMA. The two I/O ranges are both taken from the XTRA device; the modem I/O range is disabled. The first IRQ is the XTRA device IRQ, the second is the modem IRQ. Program to zero to separate the modem and XTRA devices. (*)

XTRA_HV Program to one to enable hardware volume inputs on the DSP serial port pins. Only disables DSP port if I²S0 is set to one. Program to zero to enable the XTRA device DMA or the DSP serial port.

The three MSBs in the first byte of the AD1817A EEPROM are used to verify that the EEPROM data is valid. The bits are compared to the values shown; if a mismatch is found, the EEPROM will be disabled until it is rewritten. The internal ROM will be used to perform PnP enumeration, and the MODEM and XTRA logical devices will not be available. Hardware volume will be enabled on the I²S0 port.

Byte 1

7	6	5	4	3	2	1	0
1	0	0	0	0	RSTB_EN	IRQSEL3_9	IRQSEL12_13

IRQSEL12_13 Program to one to enable IRQ 13.
Program to zero to enable IRQ 12.
IRQ_EN must be one and MODEM_EN must be zero, or this bit has no effect.

- IRQSEL3_9 Program to one to enable IRQ 9.
Program to zero to enable IRQ 3. (*)
MODEM_EN or IRQ_EN must be one, or this bit has no effect.
- RSTB_EN Program to one to enable an active-low RESET output.
Program to zero to enable XCTRL0. (*)

Byte 2

7	6	5	4	3	2	1	0
IRQSEL4_9_11	IRQSEL9_14	IRQSEL11_15	IRQSEL4_10	XTRASZ0[3:0]			

XTRASZ0[3:0] Sets the XTRA device I/O range 0 length. These bits are ANDed with the four LSBs of the address comparator result when generating $\overline{LD_SEL}$. The XTRASZ0 bits set the length of one for the XTRA device I/O ranges as follows:

XTRASZ0	I/O Range Length
0000	16
1000	8
1100	4
1110	2
1111	1

All other combinations cause aliasing, and should be avoided.

- IRQSEL4_10 Program to one to enable IRQ 10. (*, if MODEM_EN is zero)
Program to zero to enable IRQ 4. (*, if MODEM_EN is one)
- IRQSEL11_15 Program to one to enable IRQ 15. (*)
Program to zero to enable IRQ 11.
- IRQSEL9_14 Program to one to enable IRQ 14.
Program to zero to enable IRQ 9. (*)
- IRQSEL4_9_11 Program to one to enable IRQ 11. (*)
Program to zero to enable IRQ 4 (if MODEM_EN is one) or IRQ 9 (if MODEM_EN is zero).

Byte 3

7	6	5	4	3	2	1	0
XTRASZ1[3:0]				XTRA_CS	IRQ_EN	MIRQINV	XIRQINV

- XIRQINV Program to one to make LD_IRQ active-low.
Program to zero to make LD_IRQ active-high. (*)
- MIRQINV Program to one to make MDM_IRQ active-low.
Program to zero to make MDM_IRQ active-high. (*)
- IRQ_EN Program to one to enable additional IRQ channels. If MODEM_EN is zero, then two IRQs are added; if MODEM_EN is one, this bit is ignored. Program to zero to enable I²S port 1 (SUPER_EN and MODEM_EN must also be zero).
- XTRA_CS Program to one to enable a second I/O range for the XTRA or SUPER logical devices. It is identical to the first I/O range, except its size is controlled by XTRASZ1[3:0]. Program to zero to enable the XCTR1/RING_IN pin. (*) Always considered to be zero if XTRA_EN is zero.
- XTRASZ1[3:0] Sets the XTRA device I/O range one length. These bits are ANDed with the four LSBs of the address comparator result when generating $\overline{LD_SEL1}$. The XTRASZ1 bits set the length of one for the XTRA device I/O ranges as follows:

XTRASZ1	I/O Range Length
0000	16
1000	8
1100	4
1110	2
1111	1

All other combinations cause aliasing, and should be avoided.

AD1817A

USING THE AD1817A WITHOUT AN EEPROM

If the EEPROM is absent (EE_CLK pin = GND), then the flags are set as shown below:

MODEM_EN = XTRA_EN = SUPER_EN = XTRA_HV = RSTB_EN = IRQ_EN = 0

IRQSEL9_14 = MIRQINV = XIRQINV = 0

IRQSEL4_10 = IRQSEL11_15 = IRQSEL4_9_11 = 1

I²S0_HV = EE_DATA pin

PIN MUXING IN THE AD1817A

Some AD1817A options are mutually exclusive because there are a limited number of pins on the device to support them all. The tables below map functions to pin, and show how the flags must be set to assign functions to pins. For each pin, the first function listed is the default; that function is used if the EEPROM is absent or invalid.

Table XII. AD1817A Pin Muxing

PQFP	Pin Function	I/O	Flags Required
1	$\overline{\text{VOL_UP}}$	I	I2S0_HV
2	$\overline{\text{VOL_DN}}$	I	I2S0_HV
3	GND	I	I2S0_HV
68	XCTL0/PCLKO	O	!RSTB_EN
	PNPRST	O	RSTB_EN
69	XCTL1/RING	O(1)	!XTRA_EN + !XTRA_CS
	$\overline{\text{LED_SEL1}}$	O	RSTB_EN
75	IRQ(15)	O (2)	IRQSEL15_11
	IRQ(11)	O (2)	!IRQSEL15_11
76	IRQ(11)	O (2)	IRQSEL4_9_11
	IRQ(9)	O (2)	!IRQSEL4_9_11* !MODEM_EN
	IRQ(4)	O (2)	!IRQSEL4_9_11* MODEM_EN
77	IRQ(10)	O (2)	IRQSEL4_10
	IRQ(4)	O (2)	!IRQSEL4_10
78	IRQ(9)	O (2)	!IRQSEL9_14
	IRQ(14)	O (2)	IRQSEL9_14
81	IRQ(3)	O (2)	(MODEM_EN * SUPER_EN * IRQ_EN) * !IRQSEL3_9
	IRQ(9)	O (2)	(MODEM_EN * SUPER_EN * IRQ_EN) * IRQSEL3_9
82	MDM_IRQ	I	MODEM_EN
83	$\overline{\text{MDM_SEL}}$	O	MODEM_EN * !SUPER_EN
	IRQ(12)	O (2)	(!MODEM_EN + SUPER_EN) * IRQ_EN * !IRQSEL12_13
	IRQ(13)	O (2)	(!MODEM_EN + SUPER_EN) * IRQ_EN * IRQSEL12_13
97	$\overline{\text{LD_SEL}}$	O	XTRA_EN
	No Connect	O	!XTRA_EN * XTRA_HV
98	96	$\overline{\text{LD_DRQ}}$	I XTRA_EN * !XTRA_HV
		$\overline{\text{VOL_UP}}$	I XTRA_HV

Table XII. AD1817A Pin Muxing (Continued)

PQFP	Pin Function	I/O	Flags Required
99	$\overline{\text{LD_DACK}}$	O (3)	XTRA_EN * !XTRA_HV
	$\overline{\text{VOL_DN}}$	I	(XTRA_EN + XTRA_CS) * XTRA_HV
	GND	I	!XTRA_EN * XTRA_HV * !XTRA_CS
100	$\overline{\text{LD_IRQ}}$	I	XTRA_EN
	$\overline{\text{VOL_DN}}$	I	!XTRA_EN * XTRA_HV * !XTRA_CS
	GND	I	!XTRA_EN * XTRA_HV * XTRA_CS

(1) Open-drain driver with internal weak pull-up.

(2) PC_IRQ pins are three-stated if not assigned to a logical device.

(3) A pull-up or pull-down resistor may be required if EEPROM is used, because this pin is three-stated while EEPROM is read.

NOTE

The direction of some pins (input vs. output) depends on the flags. In order to prevent conflicts on pins that may be both inputs and outputs, the AD1817 and AD1817A disable the output drivers for those pins while the flags are being read from the EEPROM, and keeps them disabled if the EEPROM data is invalid.

PROGRAMMING EXTERNAL EEPROMS

The PnP EEPROM can be written only in the “Alternate Key State”; this prevents accidental EEPROM erasure when using standard PnP setup. The procedure for writing an EEPROM is:

- 1) Enter PnP configuration state and fully reset the part by writing 0x07 to PnP register 0x02. This step can be eliminated if the part has not been accessed since power-up, a previous full PnP reset or assertion of the ISA bus RESET signal.
- 2) Send the alternate initiation key to the PnP address port. EEPROM writes are disabled if the standard PnP key is used.
- 3) Enter isolation state and write a CSN to enter configuration state. Do not perform any isolation reads.
- 4) Poll PnP register 0x05 until it equals 0x01 and wait at least 336 microseconds (ensures that EEPROM is idle).
- 5) Write the second byte of your serial identifier to PnP register 0x20.
- 6) Read PnP register 0x04.
- 7) Wait for at least 464 microseconds, plus the EEPROM’s write cycle time (up to 10 ms for a Xicor X24C02).
- 8) Repeat Steps 4 through 7 for each byte in your PnP ROM, starting with the third byte of the serial identifier and ending with the final checksum byte. You must then continue to write filler bytes until 512 bytes, minus one more than the number of flag bytes, have been written. Finally, write the flag byte(s) (described above) and the first byte of the serial identifier.
- 9) Fully reset the part by writing 0x07 to PnP register 0x02.

The AD1817 or AD1817A will now act according to the contents of the EEPROM.

NOTES

Programming will not work if more than one part uses the same alternate initiation key in the system. Parts that use this alternate initiation key are the AD1815, AD1817, and AD1817A.

If a 256-byte EEPROM is used, it is not necessary to wait 10 ms after writing bytes 255 to 511, because the EEPROM will ignore them anyway.

You can skip over bytes that you don’t care to write by just performing a ROM read instead of a ROM write followed by a ROM read.

REFERENCE DESIGNS AND DEVICE DRIVERS

Reference designs and device drivers for the AD1817A are available via the Analog Devices Home Page on the World Wide Web at <http://www.analog.com>. Reference designs may also be obtained by contacting your local Analog Devices Sales representative or authorized distributor.

A typical application circuit is shown in Figure 8.

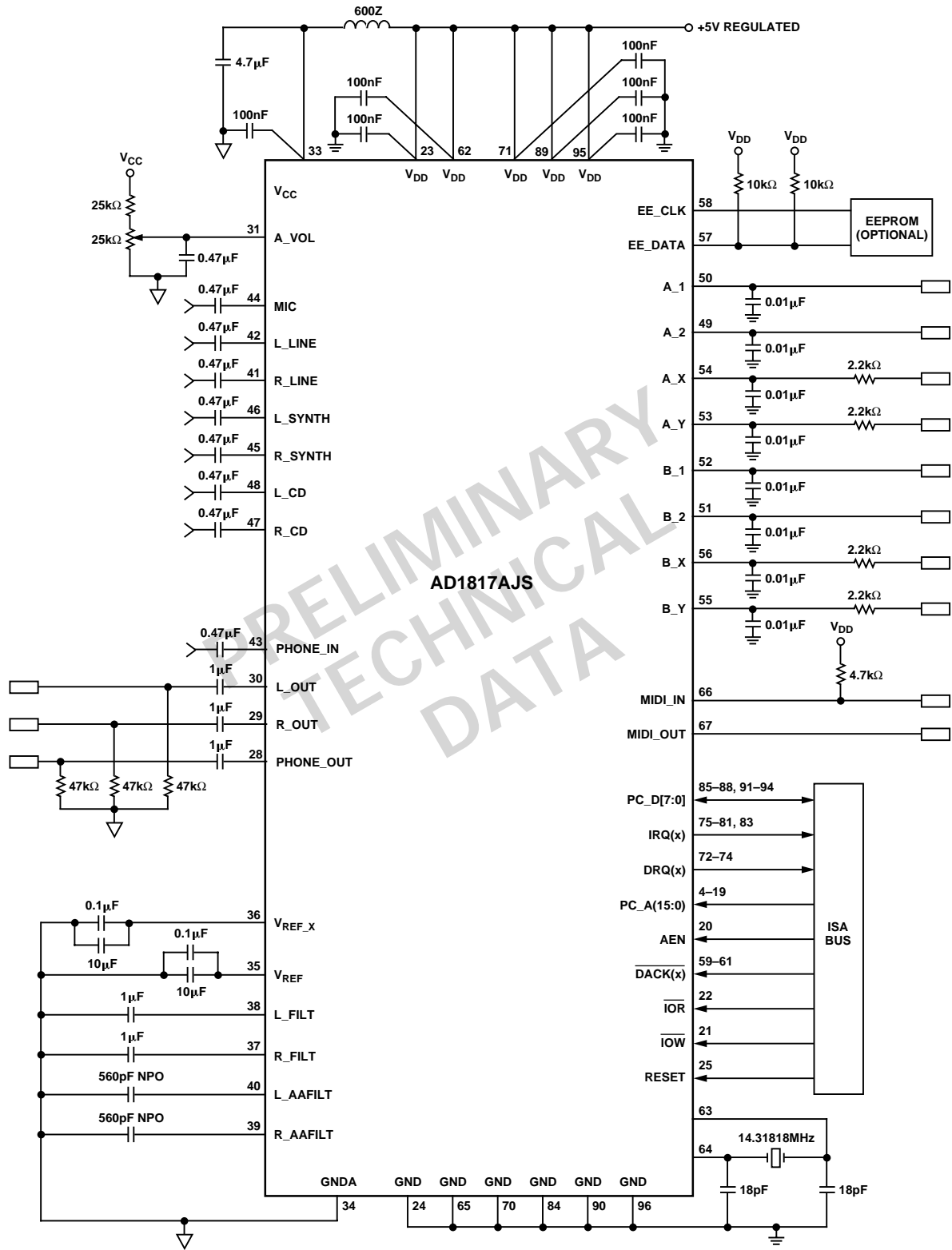
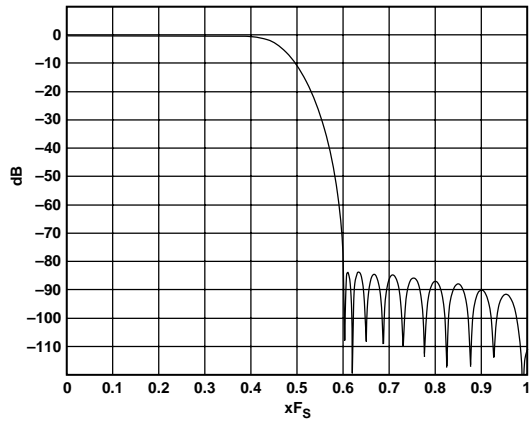
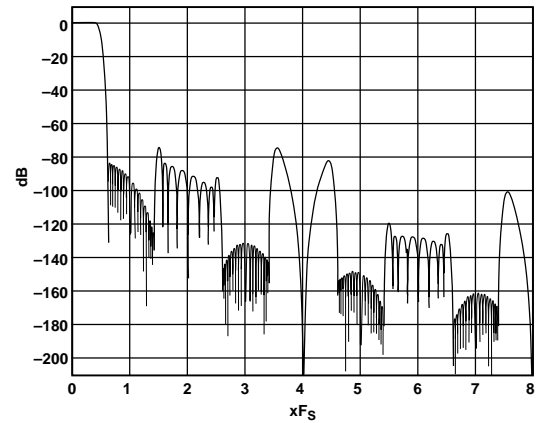

Figure 8. Typical Application Circuit



a. ADC Audio



c. DAC Audio

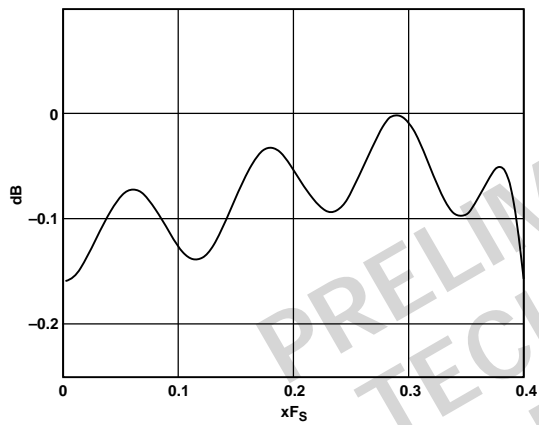

b. ADC Audio Passband

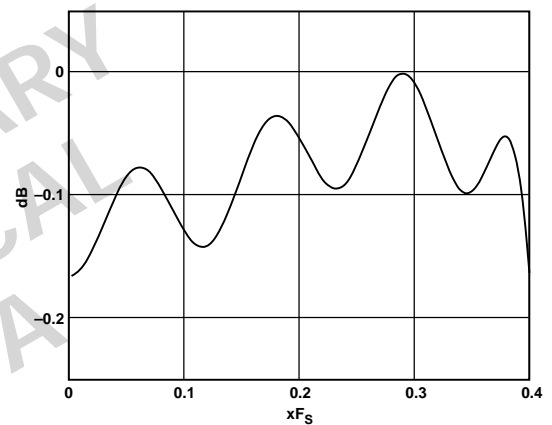

d. DAC Audio Passband

Figure 9. AD1817A Frequency Response Plots (Full-Scale Line-Level Input, 0 dB Gain). The Plots Do Not Reflect the Additional Benefits of the AD1815 Analog Filters. Out-of-Band Images Will Be Attenuated by an Additional 31.4 dB at 100 kHz.

OUTLINE DIMENSIONS

Dimensions shown in inches and (mm).

**100-Lead Plastic Quad Flatpack
(S-100)**

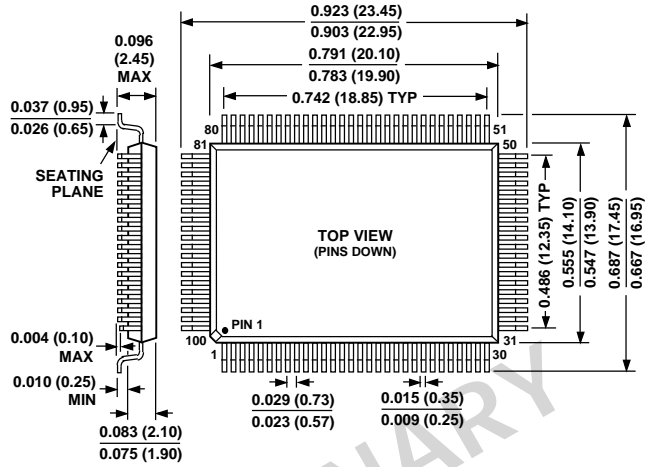

PRELIMINARY
TECHNICAL
DATA

