

5 Bit Digital Attenuator DC - 16GHz

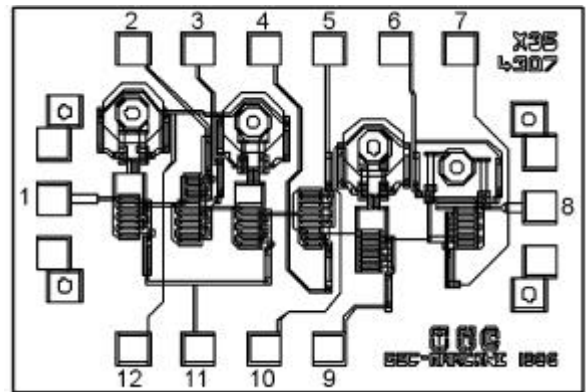

Features

- Broadband DC - 16GHz
- Low insertion loss; 3dB typ at 8GHz
- Attenuation 0.5dB steps to 15.5dB
- Fast switching speed
- Through GaAs vias for improved performance

Description

The P35-4307-000-200 is a high performance broadband Gallium Arsenide monolithic 5 bit digital attenuator offering an attenuation range of 15.5dB in 0.5dB steps. It is suitable for use in broadband communications, instrumentation and electronic warfare applications. The attenuator is controlled by the application of complimentary 0V/-5V or 0/-8V signals to the control lines in accordance with the truth tables below. The full attenuation range is achieved by modifying the control lines in combination.

The die is fabricated using MOC's 0.5µm gate length MESFET process (S20). It is fully protected using Silicon Nitride passivation for excellent performance and reliability.

Electrical Performance

Ambient temperature = 22±3°C , Z_O = 50Ω, Control voltages = 0V/-5V unless otherwise stated

Parameter	Conditions	Min	Typ	Max	Units
Insertion Loss ¹ (reference state)	50MHz - 8GHz	-	3	3.5	dB
	8GHz - 16GHz	-	4	4.5	Db
Attenuation Range	50MHz - 16GHz	-	15.5	-	dB
Step Size	50MHz - 16GHz	-	0.5	-	dB
Attenuation Accuracy	50MHz - 8GHz	-	-	±0.2 ±3%	dB
	8GHz - 16GHz	-	-	±0.3 ±10%	dB
Input Return Loss ²	50MHz - 16GHz	12	20	-	dB
Output Return Loss ²	50MHz - 16GHz	15	25	-	dB
Switching Speed	50% Control to 1 0% or 90%RF	-	5	10	nS

Notes

1. Insertion Loss measured in low loss state.
Return Loss measured in low loss switch state.

Typical Performance at 22°C

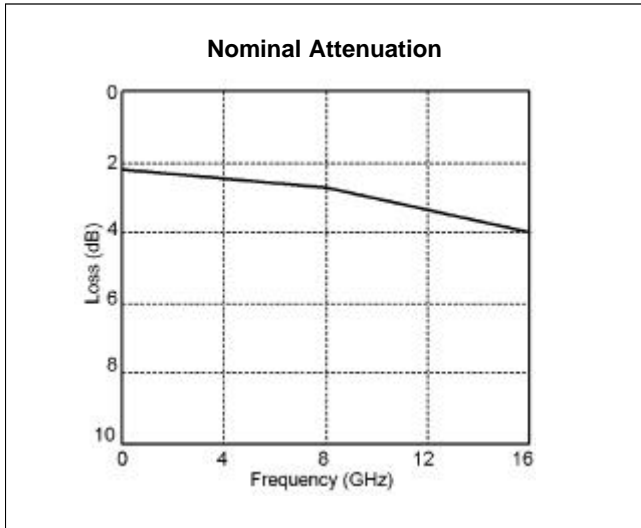
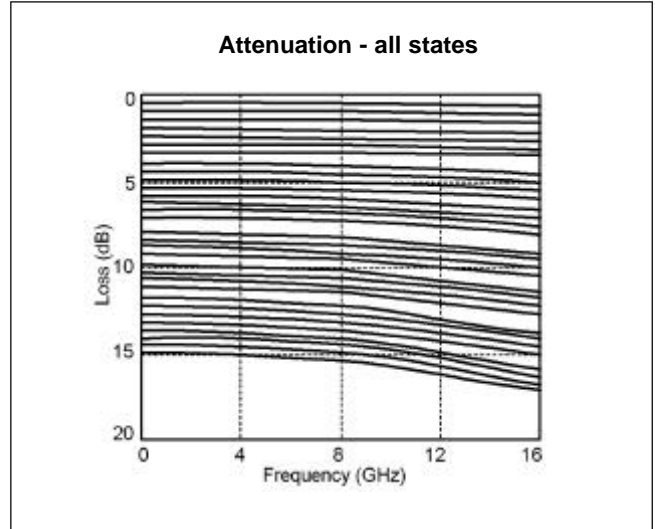
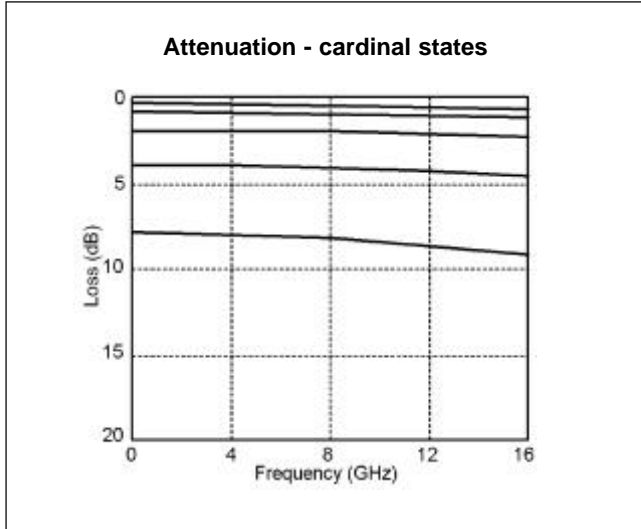

Absolute Maximum Ratings

Max control voltage	-8V
Max I/P power	+25 dBm
Operating temperature	-60°C to +125°C
Storage temperature	-65°C to +150°C

Attenuator Schematic

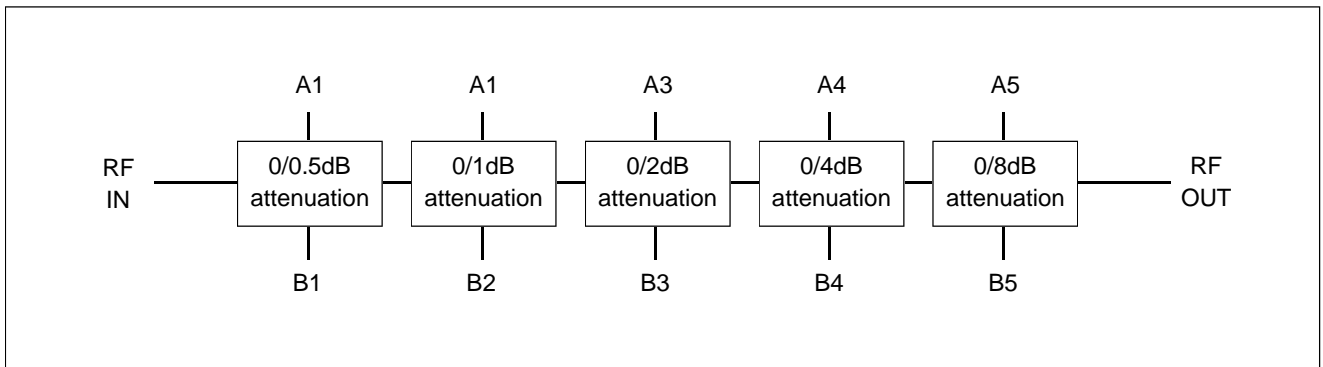

Chip Outline

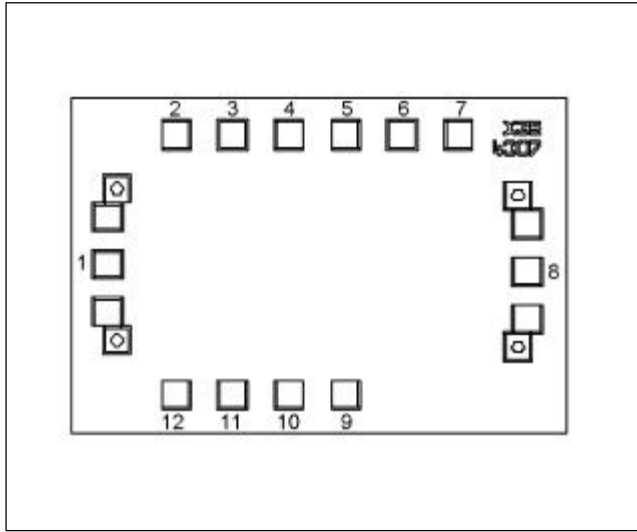

Die size:	2.05 x 1.37mm
Bond pad size	120µm x 120µm
Die thickness:	200µm

Pad Details

Pad	Function
1	RF Input
2	B1
3	A1
4	B2
5	A2
6	B3
7	A3
8	RF Input
9	A4
10	B4
11	A5
12	B5

Switching Truth Table

Control Line										Attenuation
0.5dB bit		1dB bit		2dB bit		4dB bit		8dB bit		
A1	B1	A2	B2	A3	B3	A4	B4	A5	B5	
0V	-5V	0V	-5V	0V	-5V	0V	-5V	0V	-5V	Reference
-5V	0V	0V	-5V	0V	-5V	0V	-5V	0V	-5V	+0.5dB
0V	-5V	-5V	0V	0V	-5V	0V	-5V	0V	-5V	+1dB
0V	-5V	0V	-5V	-5V	0V	0V	-5V	0V	-5V	+2dB
0V	-5V	0V	-5V	0V	-5V	-5V	0V	0V	-5V	+4dB
0V	-5V	0V	-5V	0V	-5V	0V	-5V	-5V	0V	+8dB

Handling, Mounting and Bonding Instructions

The back of the die is gold metallized and can be die-attached manually onto gold, eutectically with Au-Sn (80:20) or with low temperature conductive epoxy. The maximum allowable die temperature is 310°C for 2 minutes. Bonds should be made onto the exposed gold pads with 17 or 25 microns pure gold or half-hard gold wire. Bonding should be achieved with the die face at 225°C to 275°C with a heated thermosonic wedge (approx. 125°C) and a maximum force of 60 grams. Ball bonds may be used but care must be taken to ensure the ball size is compatible with the bonding pads shown. The length of the bond wires should be minimised to reduce parasitic inductance, particularly those to the RF and ground pads.

Ordering Information: P35-4307-000-200

The data and product specifications are subject to change without notice. These devices should not be used for device qualification and production without prior notice.

© Marconi Optical Components Ltd 2001

MOC, Caswell, Towcester, Northants, NN12 8EQ, Tel:+44 1327 356468 Fax +44 1327 356698

462/SM/01303/200 Issue 1/2

The logo for Marconi, featuring the word "Marconi" in a stylized, cursive font with a horizontal line underneath.

www.moc.marconi.com