

GP2W1001YP0F

IrDA Compliant Transceiver Module
9.6 kb/s to 4 Mb/s (FIR)
Low Profile
Low Consumption Current



■ Description

The **GP2W1001YP0F** is an infrared transceiver module for IrDA ver. 1.4 (FIR).

The transceiver consists of a pin-photo diode, infrared emitter and control IC in a single package.

■ Features

1. Compliant with the IrDA 1.4 (FIR)
Transmission speed : 9.6 kb/s to 4 Mb/s
Transmission distance : 1 m
2. Small package
L 10.0 × W 4.38 × H 3.53 mm
3. Peak emission wavelength : 880 nm
4. Side view type
5. Soldering reflow type
6. Shield type
7. Low consumption current due to shutdown function
(Consumption current at shutdown mode : Max. 1.0 μ A)
8. Operates from 2.7 to 5.5 V

■ Agency approvals/Compliance

1. Compliant with IEC60825-1 class 1 eye safety standard
2. Compliant with RoHS directive (2002/95/EC)
3. Content status of six substances specified in
“ Management Methods for Control of Pollution Caused
by Electronic Information Products Regulation ”
(popular name : *China RoHS*)
(Chinese : 电子信息产品污染控制管理办法)
; refer to page 13
4. Lead (Pb) free device

■ Applications

1. Mobile equipment
(Cellular phone, Pager, Smart phone, PDAs,
Portable printer, etc.)
2. Digital imaging equipment
(Digital camera, Photo imaging printer)
3. POS equipment
4. Personal computers
5. Personal information tools

Notice The content of data sheet is subject to change without prior notice.

In the absence of confirmation by device specification sheets, SHARP takes no responsibility for any defects that may occur in equipment using any SHARP devices shown in catalogs, data books, etc. Contact SHARP in order to obtain the latest device specification sheets before using any SHARP device.

Block diagram

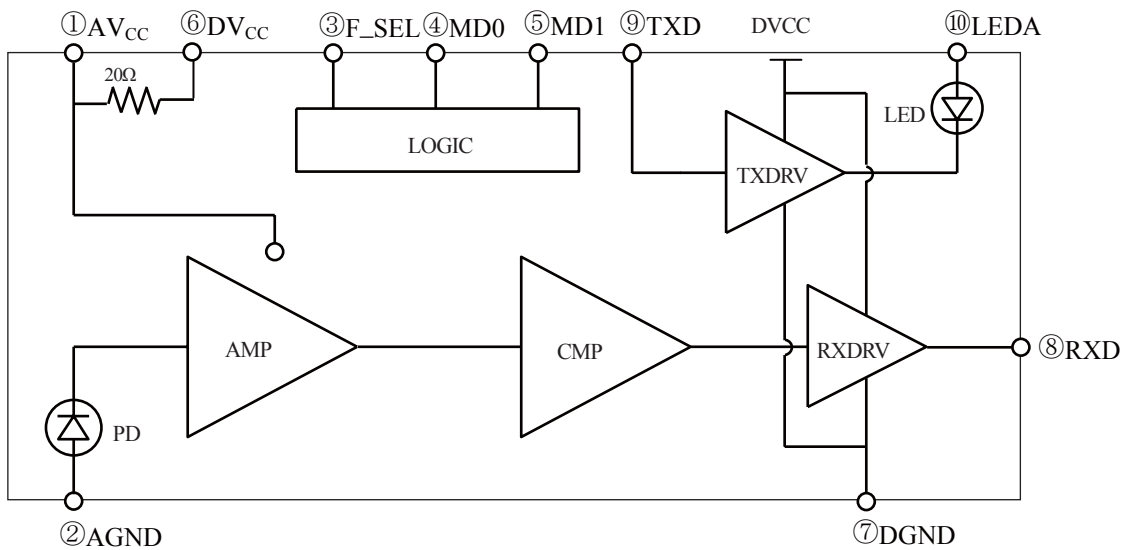

Outline Dimensions

(Unit : mm)

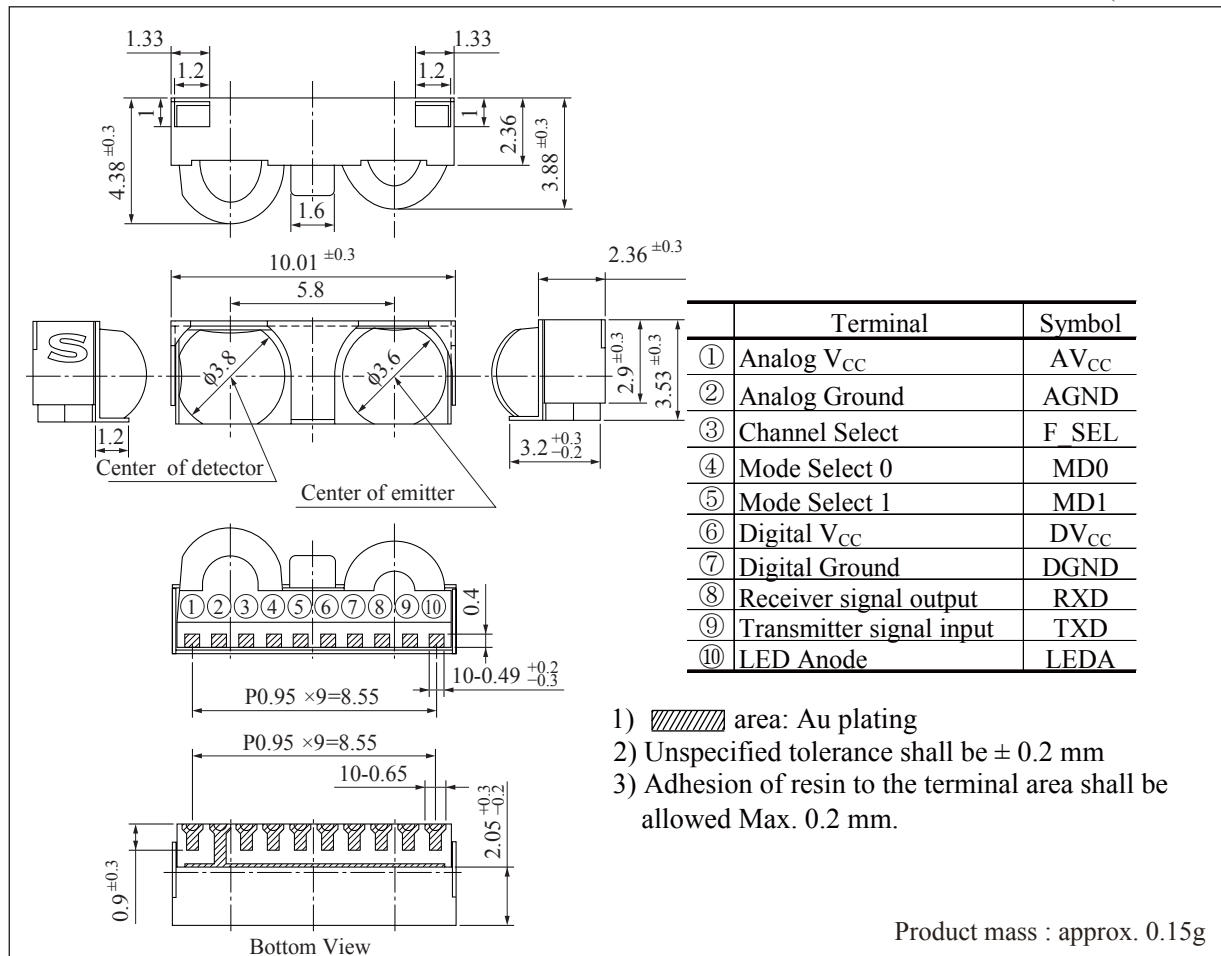

Recommended PCB Foot Pattern

Dimensions are shown for reference

(Unit:mm)

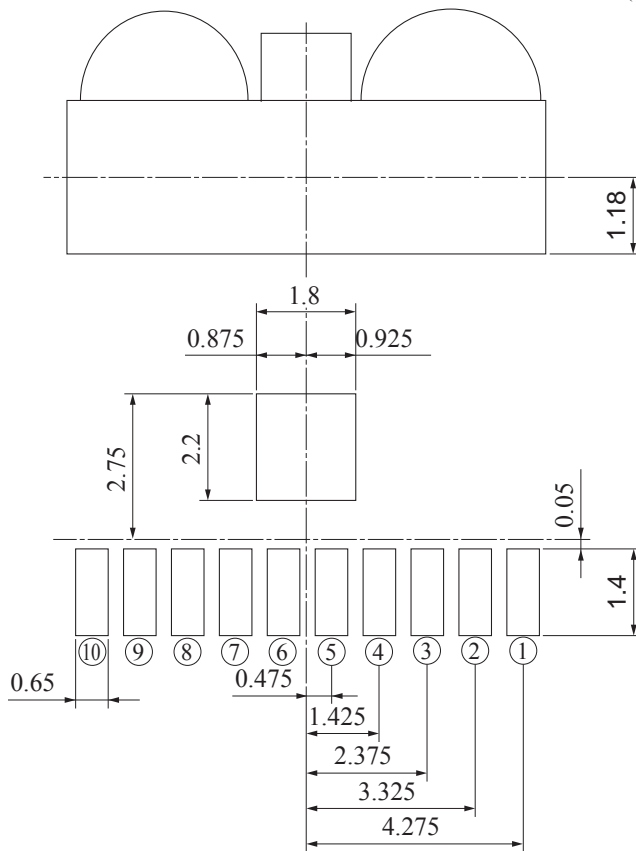

	Terminal	Symbol
①	Analog V _{CC}	AV _{CC}
②	Analog Ground	AGND
③	Channel Select	F_SEL
④	Mode Select 0	MD0
⑤	Mode Select 1	MD1
⑥	Digital V _{CC}	DV _{CC}
⑦	Digital Ground	DGND
⑧	Receiver signal output	RXD
⑨	Transmitter signal input	TXD
⑩	LED Anode	LEDA

Recommended Size of Solder Creamed Paste (Reference)

(unit : mm)

Dimensions are shown for reference.
Please open the solder mask as below
so that the size of solder creamed paste
for this device before reflow soldering
must be as large as one of the foot
pattern land indicated for reference.

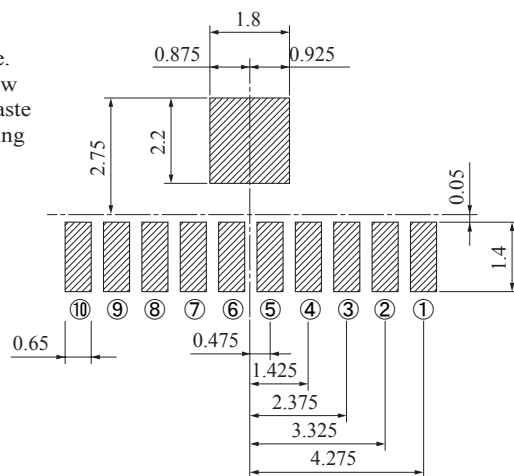

▨ : Solder paste area

Absolute Maximum Ratings (Ta=25°C)

Parameter	Symbol	Rating	Unit
Supply voltage	V _{CC}	6	V
LED Supply voltage	V _{LEDA}	6	V
Transmission signal duty ratio	D _u	50	%
Peak forward current	I _{FM}	600	mA
Operating temperature	T _{opr}	-10 to +70	°C
Storage temperature	T _{stg}	-20 to +85	°C

Note) Transmission signal duty ratio show the time share of H level of transmission wave at TX terminal. The frequency shall be 1kHz or more.

Electro-optical Characteristics (Ta=25±3°C, V_{CC}=3.3±0.1V, 5±0.1V, Ambient illuminance of detecting face:10 lx or less)

Parameter	Symbol	Rating	MIN.	TYP.	MAX.	Unit
Current consumption at no input signal	I _{CC}	RXOUT:H, TXIN:L, V _{CC} =3.3V	—	—	1.2	mA
		RXOUT:H, TXIN:L, V _{CC} =5.0V	—	—	1.5	mA
Current consumption at shutdown mode	I _{CC-S}	RXOUT:H, TXIN:L, V _{CC} =3.3V	—	0.1	1	μA
		RXOUT:H, TXIN:L, V _{CC} =5.0V	—	0.2	2	μA
LED peak current	I _{CCP}	Peak value, V _{CC} =3.3V(R _L =2.0Ω), V _{CC} =5.0V(R _L =5.6Ω)	—	400	600	mA
Receiver wakeup time	t _{RSd}		—	—	1.5	ms
Receive sensitivity(θ≦±15°)	S _{rx0}	SIR:9.6k to 115.2kb/s	0.04	—	5000	W/m ²
		FIR:1.152M/4Mb/s	0.1	—	5000	
RXOUT terminal "L" level	V _{OL}	V _{CC} =3.3,5.0V	—	—	0.4	V
RXOUT terminal "H" level	V _{OH}	V _{CC} =3.3,5.0V	V _{CC} -0.4	—	—	V
Rise time	T _{trA}	SIR:9.6k to 115.2kb/s	—	—	200	ns
	T _{trB}	FIR:1.152M/4Mb/s	—	—	40	
Fall time	T _{frA}	SIR:9.6k to 115.2kb/s	—	—	200	ns
	T _{frB}	FIR:1.152M/4Mb/s	—	—	40	
Peak receive wavelength	λ _{rx}		—	940	—	nm
RXOUT terminal pulse width	t _{w1}	SIR mode,9.6kb/s ^{*1}	1	—	22	μs
	t _{w2}	SIR mode,115.2kb/s ^{*1}	1	—	4	μs
	t _{w3}	FIR mode,1.152Mb/s ^{*1}	110	—	500	ns
	t _{w4}	FIR mode,4Mb/s (Single) ^{*1}	85	—	165	ns
Maximum receive distance	L	^{*1}	1	—	—	m
Peak emission wave length	λ _{tx}		850	880	900	nm
Radiant intensity	I _{ELφ}	Low Power	—	15	—	mW/sr
	I _{EMφ}	Middle Power	—	60	—	
	I _{EFφ}	Full Power(θ≦±15°)	100	—	500	
TXIN terminal "L" level	V _{IL1}	V _{CC} =3.3,5.0V	—	—	V _{CC} ×0.2	V
TXIN terminal "H" level	V _{IH1}	V _{CC} =3.3,5.0V	V _{CC} ×0.67	—	—	V
TXIN terminal input current	I _{IL}	TXIN=GND	-0.1	0	0.1	μA
	I _{IH}	TXIN=V _{CC} =5.0V	—	—	50	
Logic terminal "L" level	V _{IL2}	Terminal F SEL,MID0,MD1 V _{CC} =3.3,5.0V	—	—	V _{CC} ×0.33	V
Logic terminal "H" level	V _{IH2}	Terminal F SEL,MID0,MD1 V _{CC} =3.3,5.0V	V _{CC} ×0.67	—	—	V
Output Radiant rise time	t _{rtx}		—	—	40	ns
Output Radiant fall time	t _{ftx}		—	—	40	ns

*1 Refer to Fig. 2, 3

Recommended Operating Conditions (Ta=25°C)



Parameter	Symbol	Rating	Unit
Supply voltage	V _{CC}	2.7 to 5.5	V
LED Supply voltage	V _{LED}	2.7 to 7.0	V
Operating temperature	T _{opr}	0 to +70	°C
Data rate	BR	9.6k to 4M	b/s

Truth Table

Input		Output	
TXD (Transmitter)	Receiver	State of LED (Transmitter)	RXD terminal
High	–	ON	X
Low	ON	OFF	Low
Low	OFF	OFF	High

X:Do not care

Input Output Logic Table

MD0	MD1	F_SEL	TXD	RXD terminal mode	TXO *2	Remarks
1	0	X	0	Shut down	Shut down	–
	0	1	0	RXA	X	Latch TXD
	0	1	1	RXB	X	Latch TXD
0	0	0	X	RXA	HPW	TXO Output High Power mode
0	1	0	X	↓	MPW	TXO Output Middle Power mode
1	1	0	X	↓	LPW	TXO Output Low Power mode
0	0	1	X	RXB	HPW	TXO Output High Power mode
0	1	1	X	↓	MPW	TXO Output Middle Power mode
1	1	1	X	↓	LPW	TXO Output Low Power mode

*1 F_SFL → 0:reset latching state of TXD, and turn to RXA channel.

*2 When a power supply is on, F_SFL should be Low.

*3 When communication starts from RXB channel mode, once select RXA channel mode and change RXB channel mode.

*4 RXA:RXA channel mode:115kb/s or less (SIR 115.2kb/s, 9600b/s)

*5 RXB:RXB channel mode:115kb/s or more (FIR 1.152Mb/s, 4Mb/s)

Fig.1 Recommended External Circuit

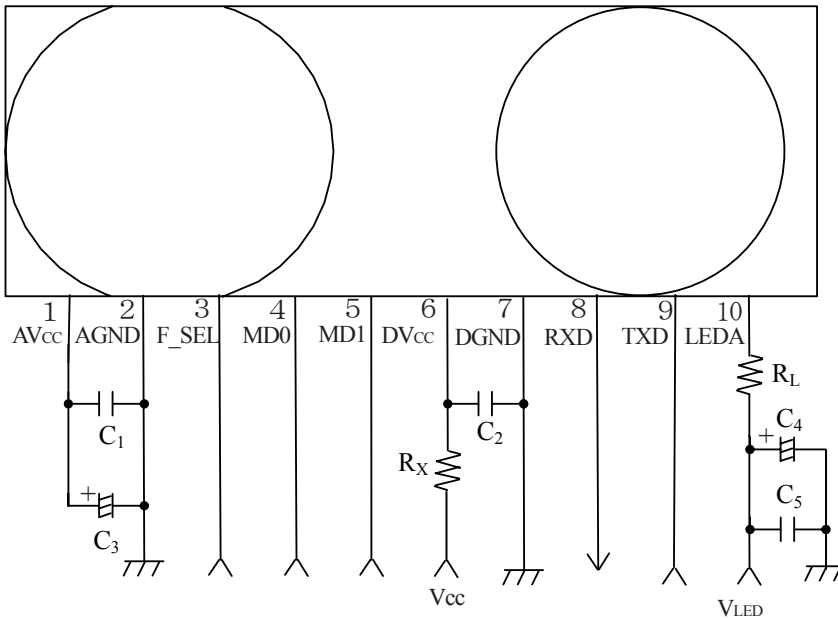

Components	Recommended values
C ₁ ,C ₂	1.0μF±10%(Note)
C ₃	4.7μF±10%(Note)
R _X	1 to 10Ω 1/8W
R _L	2.0Ω±5% 1/2W (V _{LED} =3.3V)
	5.6Ω±5% 1/2W (V _{LED} =5.0V)
C ₄	5.6μF±10%(Note)
C ₅	0.1μF±10%(Note)

(Note)1. Component chooses the most suitable constant of C₁,C₂,C₃,C₄ and C₅ according to the noise level and noise frequency of a power supply. Depending on the noise level of a power supply, and noise frequency, a noise may be unable to be removed only by capacitor of a standard circuit. At this time, pulses other than a signal may be outputted from a RXD terminal in a specific communication distance. Please confirm with the system that it is satisfactory with each transmission speed in all communication distance at the time of examination. When there is a noise ingredient which cannot be removed only by C₁,C₂,C₃, please insert R_x(1 to 10Ω) and it after a check. When there is a problem, please use it after a check as a noise measure Circuit.

2. Don't connect an Avcc terminal with power supply because it is the connection of only capacitor.

Fig.2 Output Waveform Specification(Receiver side)($C_L \leq 10pF$)

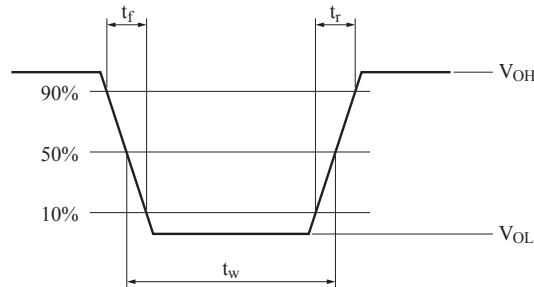
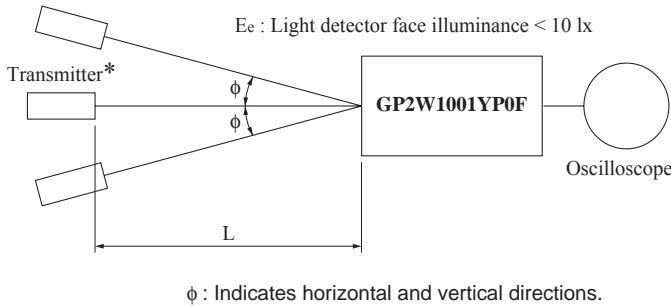

Fig.3 Standard Optical System(Receiver side)



Data rate	T_1	T_2	T_2/T_1	Radiant intensity
9.6kb/s	104 μ s	19.53 μ s	3/16	40mW/sr
115.2kb/s	8.68 μ s	1.63 μ s	3/16	40mW/sr
1.152Mb/s	868ns	217ns	1/4	100mW/sr
4Mb/s	500ns	125ns	1/4	100mW/sr

* The light emitting diode (SHARP **GL710**, $\lambda_p=850$ to $900nm$) is used as the transmitter, where the following continuous signals are transmitted.
In Fig.3, output signal shall be complete receiver side electro-optical characteristics.

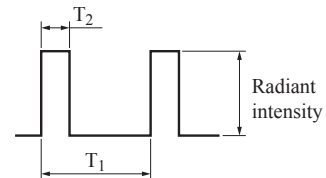

Fig.4 Output Waveform Specification(Transmitter side)

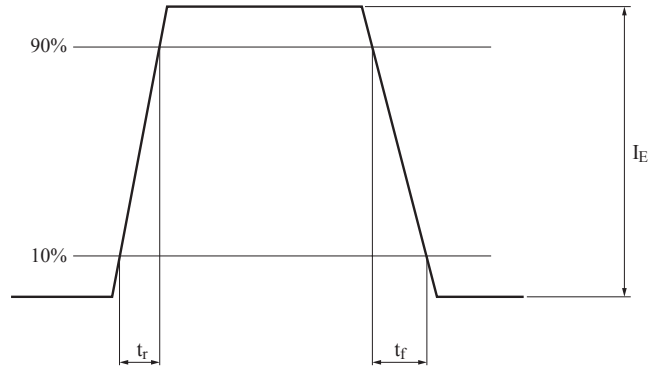

Fig.5 Standard Optical System(Transmitter side)

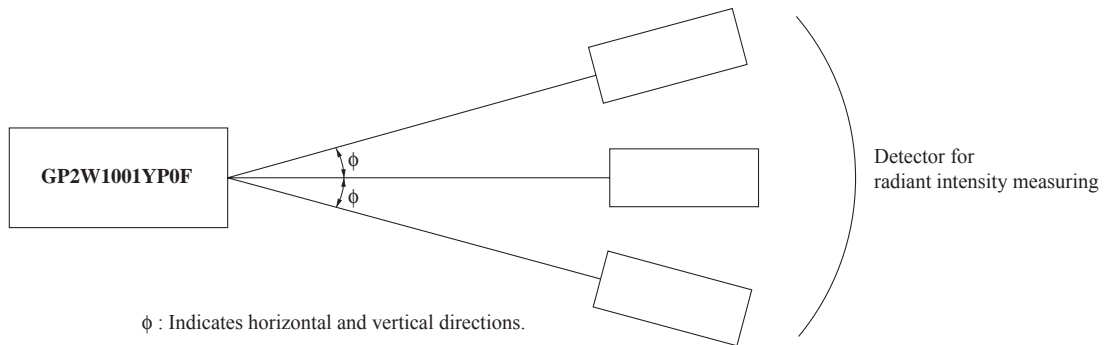

Fig.6 Recommended Circuit of Transmitter side

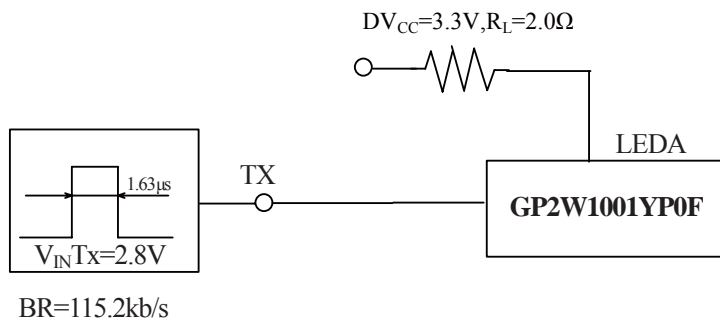
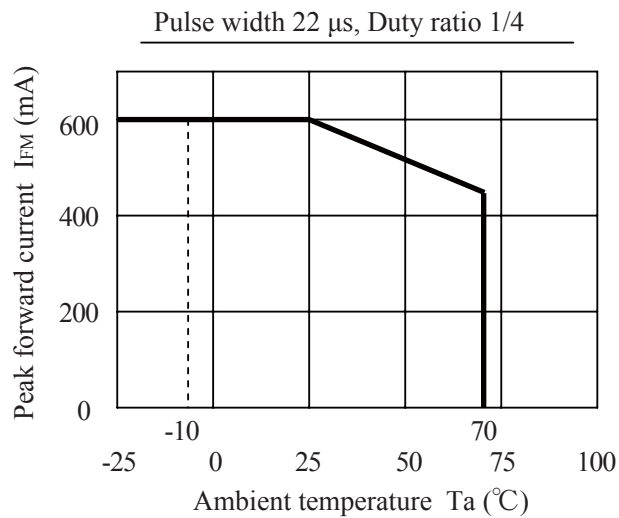

Fig.7 Peak Forward Current vs. Ambient Temperature



Notes

- (1) When the system (program) is designed, the Turn Around Time shall be secured by considering 500 μ s or more that is specified to IrDA.
Then, this Turn Around Time means the time when this device does not temporarily detect the signal light, since the transmitted light from the transceiver reaches the detector side of the transceiver.
- (2) As it is necessary 1.5 ms or more (at $T_a = 25$ °C, no input signal) to return from shut-down mode to ready-operation mode, please consider this point at the system (program) designing.
Also, please confirm thoroughly the operation in actual application.
- (3) When there is much external disturbing light source is located near this transceiver and the detector face receiver much external disturbing light, there is case that the pulse other than signal output is generated as noise on output terminal of this transceiver. Please consider the lay-out and structure to reduce disturbing light on the detector face.
- (4) In case that this sensor is adopted in IR communication system, please use it according to the signal method which is specified by [Serial Infrared Physical Layer Link Specification Version 1.4] published by Infrared Data Association. False operation may happen if the different signal method is used.
- (5) In circuit designing, make allowance for the degradation of light emitting diode output that results from long continuous operation. (50 % degradation/5 years)

■Soldering Method

1. In case of solder reflow

Please carry out only one time soldering at the temperature and the time within the temperature profile as shown in the figure below.

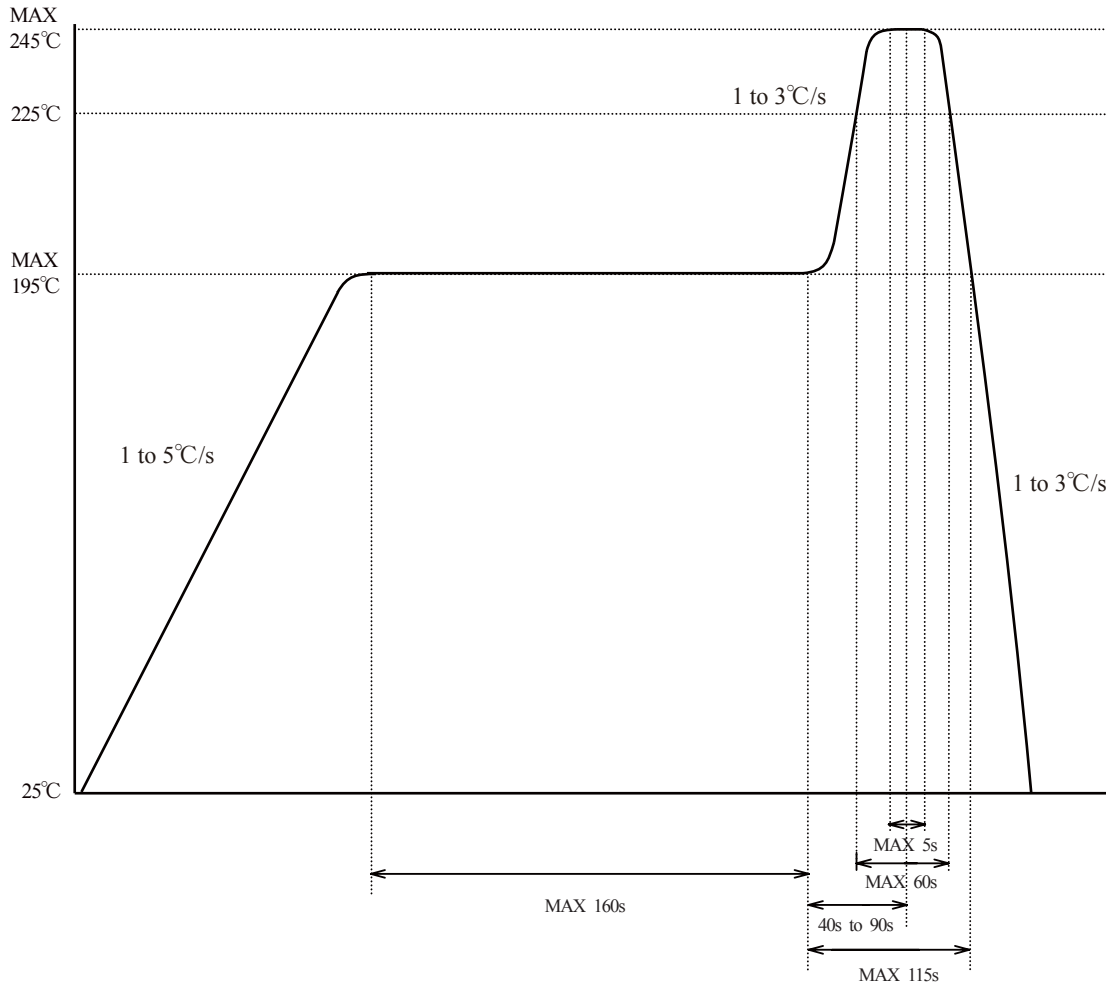

2. Other precautions

An infrared lamp used to heat up for soldering may cause a localized temperature rise in the resin. So keep the package temperature within that specified in Item 1. Also avoid immersing the resin part in the solder. Even if within the temperature profile above, there is the possibility that the gold wire in package is broken in case that the deformation of PCB gives the affection to lead pins. Please use after confirming the conditions fully by actual solder reflow machine.

3. Soldering

- Soldering iron shall be less than 25W, and temperature of point of soldering iron shall use at 260°C or less.
- Soldering time shall be within 5s.
- Soldered product shall treat at normal temperature.

Package specification

- Tape and Reel package
- 2000 pcs/reel

Taping materials

Name	Material	Counter measure for ESD
Reel	PPE	Coped(Conductivity)
Carrier tape	PC	Coped(Conductivity)
Cover tape	PET	Coped(Conductivity)

Carrier tape structure and Dimensions

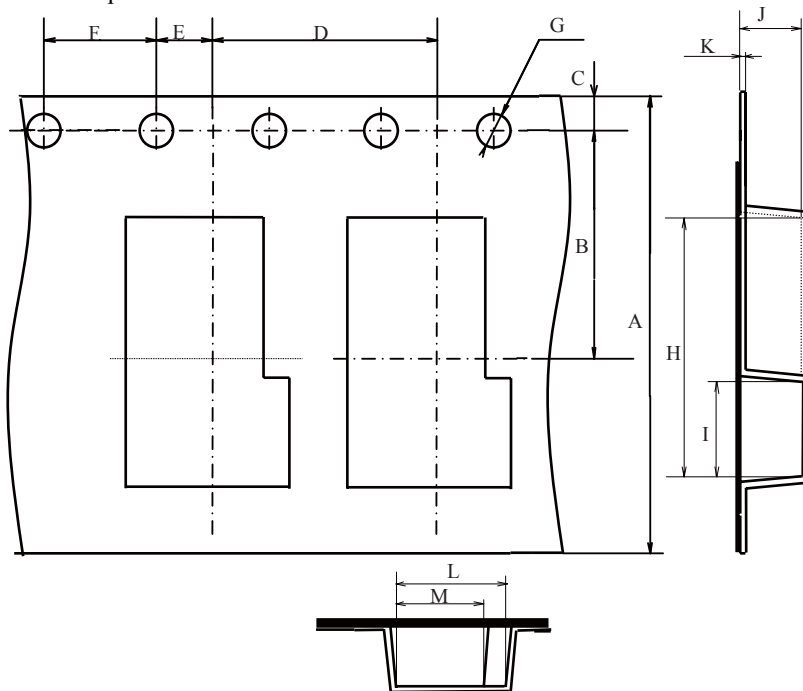

Dimension List

(Unit : mm)

A	B	C	D	E	F	G	H	I	J	K	L	M
16.0±0.3	7.5±0.1	1.75±0.1	8.0±0.1	2.0±0.1	4.0±0.1	$\phi 1.5^{+0.1}_{-0.0}$	10.6±0.1	4.0±0.1	4.0±0.1	0.33±0.05	4.6±0.1	4.1±0.1

Reel structure and Dimensions

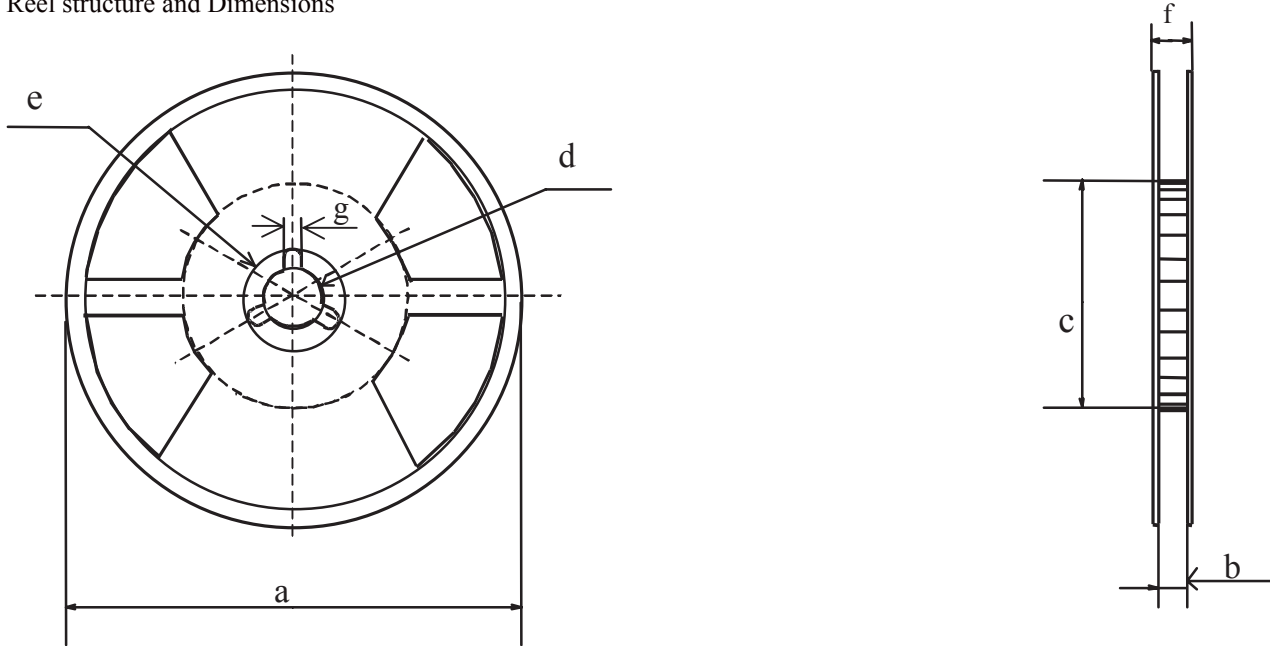

(Unit : mm)

a	b	c	d
$\phi 330 \pm 2$	17.5 ± 1	$\phi 100 \pm 1$	$\phi 13 \pm 0.2$
e	f	g	
$\phi 21 \pm 0.8$	22.5 ± 0.1	2 ± 0.5	

Direction of product insertion

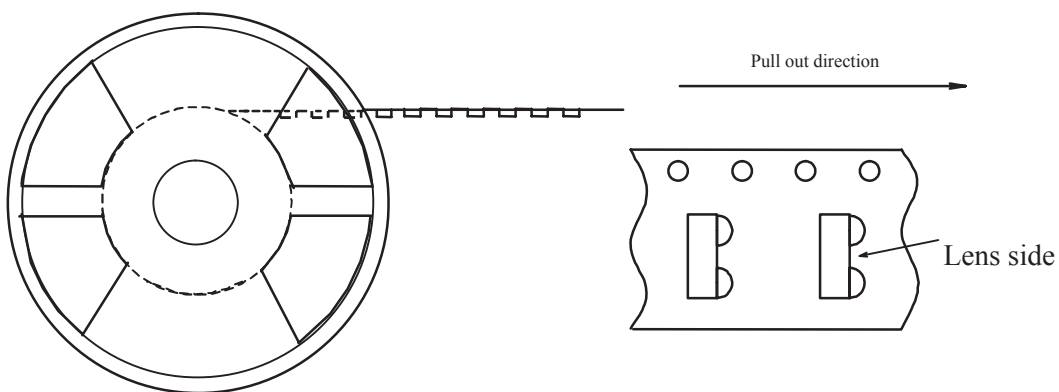

● **Cleaning Instructions**

Solvent cleaning :

Solvent temperature 45°C or less, Immersion for 3 min or less

Ultrasonic cleaning :

The effect to device by ultrasonic cleaning differs by cleaning bath size, ultrasonic power output, cleaning time, PCB size or device mounting condition etc.

Please test it in actual using condition and confirm that doesn't occur any defect before starting the ultrasonic cleaning. The cleaning shall be carried out with solvent below.

Recommended Solvent materials :

Ethyl alcohol, Methyl alcohol, Isopropyl alcohol

● **Presence of ODC etc.**

This product shall not contain the following materials.

And they are not used in the production process for this product.

Regulation substances : CFCs, Halon, Carbon tetrachloride, 1.1.1-Trichloroethane (Methylchloroform)

Specific brominated flame retardants such as the PBB and PBDE are not used in this product at all.

- The RoHS directive (2002/95/EC)

This product complies with the RoHS directive (2002/95/EC).

Object substances: lead, mercury, cadmium, hexavalent chromium, polybrominated biphenyls (PBB) and polybrominated diphenyl ethers (PBDE)

- Content of six substances specified in “ Management Methods for Control of Pollution Caused by Electronic Information Products Regulation ” (Chinese : 电子信息产品污染控制管理办法)

Category	Toxic and hazardous substances					
	Lead (Pb)	Mercury (Hg)	Cadmium (Cd)	Hexavalent chromium (Cr ⁶⁺)	Polybrominated biphenyls (PBB)	Polybrominated diphenyl ethers (PBDE)
Infrared data communication device	✓	✓	✓	✓	✓	✓

✓: indicates that the content of the toxic and hazardous substance in all the homogeneous materials of the part is below the concentration limit requirement as described in SJ/T 11363-2006 standard.

■ Important Notices

· The circuit application examples in this publication are provided to explain representative applications of SHARP devices and are not intended to guarantee any circuit design or license any intellectual property rights. SHARP takes no responsibility for any problems related to any intellectual property right of a third party resulting from the use of SHARP's devices.

· Contact SHARP in order to obtain the latest device specification sheets before using any SHARP device. SHARP reserves the right to make changes in the specifications, characteristics, data, materials, structure, and other contents described herein at any time without notice in order to improve design or reliability. Manufacturing locations are also subject to change without notice.

· Observe the following points when using any devices in this publication. SHARP takes no responsibility for damage caused by improper use of the devices which does not meet the conditions and absolute maximum ratings to be used specified in the relevant specification sheet nor meet the following conditions:

(i) The devices in this publication are designed for use in general electronic equipment designs such as:

- Personal computers
- Office automation equipment
- Telecommunication equipment [terminal]
- Test and measurement equipment
- Industrial control
- Audio visual equipment
- Consumer electronics

(ii) Measures such as fail-safe function and redundant design should be taken to ensure reliability and safety when SHARP devices are used for or in connection

with equipment that requires higher reliability such as:

- Transportation control and safety equipment (i.e., aircraft, trains, automobiles, etc.)
- Traffic signals
- Gas leakage sensor breakers
- Alarm equipment
- Various safety devices, etc.

(iii) SHARP devices shall not be used for or in connection with equipment that requires an extremely high level of reliability and safety such as:

- Space applications
- Telecommunication equipment [trunk lines]
- Nuclear power control equipment
- Medical and other life support equipment (e.g., scuba).

· If the SHARP devices listed in this publication fall within the scope of strategic products described in the Foreign Exchange and Foreign Trade Law of Japan, it is necessary to obtain approval to export such SHARP devices.

· This publication is the proprietary product of SHARP and is copyrighted, with all rights reserved. Under the copyright laws, no part of this publication may be reproduced or transmitted in any form or by any means, electronic or mechanical, for any purpose, in whole or in part, without the express written permission of SHARP. Express written permission is also required before any use of this publication may be made by a third party.

· Contact and consult with a SHARP representative if there are any questions about the contents of this publication.