



T7234, T7237, and T7256 Compliance with the New ETSI PSD Requirement

(Refer to the T7234, T7237, and T7256 ISDN transceiver data sheets.)

Telecommunication Standard

The European Telecommunications Standards Institute (ETSI) has identified a change in the requirement of the power spectral density (PSD) for Basic Rate Interface ISDN.

Section A.12.4, Power Spectral Density, of ETSI TS080 states the following:

- The upper boundary of the power spectral density of the transmitted signal shall be as shown in Figure 1, below.
- Measurements to verify compliance with this requirement are to use a noise power bandwidth of 1.0 kHz.
- Systems deployed before January 1, 2000 do not have to meet this PSD requirement but shall meet the PSD requirements as defined in ETR 080 edition 2. It is, however, expected that these systems will also meet the PSD requirements of TS080 edition 3. Some narrowband violations could occur and should be tolerated.

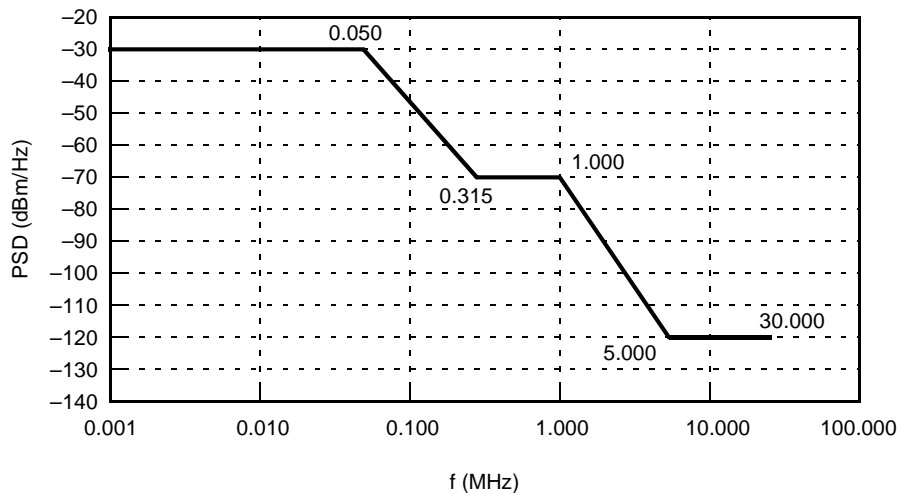

5-7388F

Figure 1. Upper Boundary of Power Spectral Density from NT1 and LT

The existing SCNT1 family (T7234A, T7237A, and T7256A) of U-interface transceivers fully comply with this standard.

Conformance to the above requirement has been fully verified, and test reports are available upon request.

For additional information, contact your Microelectronics Group Account Manager or the following:

INTERNET: <http://www.lucent.com/micro>

E-MAIL: docmaster@micro.lucent.com

N. AMERICA: Microelectronics Group, Lucent Technologies Inc., 555 Union Boulevard, Room 30L-15P-BA, Allentown, PA 18103

1-800-372-2447, FAX 610-712-4106 (In CANADA: **1-800-553-2448**, FAX 610-712-4106)

ASIA PACIFIC: Microelectronics Group, Lucent Technologies Singapore Pte. Ltd., 77 Science Park Drive, #03-18 Cintech III, Singapore 118256

Tel. (65) 778 8833, FAX (65) 777 7495

CHINA: Microelectronics Group, Lucent Technologies (China) Co., Ltd., A-F2, 23/F, Zao Fong Universe Building, 1800 Zhong Shan Xi Road, Shanghai 200233 P. R. China **Tel. (86) 21 6440 0468, ext. 316**, FAX (86) 21 6440 0652

JAPAN: Microelectronics Group, Lucent Technologies Japan Ltd., 7-18, Higashi-Gotanda 2-chome, Shinagawa-ku, Tokyo 141, Japan

Tel. (81) 3 5421 1600, FAX (81) 3 5421 1700

EUROPE: Data Requests: MICROELECTRONICS GROUP DATALINE: **Tel. (44) 1189 324 299**, FAX (44) 1189 328 148

Technical Inquiries: GERMANY: **(49) 89 95086 0** (Munich), UNITED KINGDOM: **(44) 1344 865 900** (Ascot),

FRANCE: **(33) 1 40 83 68 00** (Paris), SWEDEN: **(46) 8 594 607 00** (Stockholm), FINLAND: **(358) 9 4354 2800** (Helsinki),

ITALY: **(39) 02 6608131** (Milan), SPAIN: **(34) 1 807 1441** (Madrid)

Lucent Technologies Inc. reserves the right to make changes to the product(s) or information contained herein without notice. No liability is assumed as a result of their use or application. No rights under any patent accompany the sale of any such product(s) or information.





T7234, T7237, and T7256 Data Sheet Advisory

(Refer to the T7234, T7237, and T7256 ISDN transceiver data sheets.)

The Technology and Telecommunications Standard sections below denote the differences between the T7234, T7237, and T7256 and the T7234A, T7237A, and T7256A.

Technology

- The T-7234- -ML, T-7237- -ML, and T-7256- -ML2 are 0.9 μm CMOS technology devices.
- The T-7234A- -ML, T-7237A- -ML, and T-7256A- -ML are 0.6 μm CMOS technology devices.

Telecommunication Standard

In 1996, the European Telecommunications Standards Institute (ETSI) added a microinterruption immunity requirement to ETR 080 (Sections 5.4.5 and 6.2.5).

Section 5.4.5 in ETSI ETR 080 states the following:

- A microinterruption is a temporary line interruption due to external mechanical activity on the copper wires constituting the transmission path.
- The effect of a microinterruption on the transmission system can be a failure of the digital transmission link.
- The objective of this requirement is that the presence of a microinterruption of specified maximum length shall not deactivate the system, and the system shall activate if it has deactivated due to longer interruption.

Section 6.2.5 in ETSI ETR 080 states that:

- A system shall tolerate a microinterruption up to $t = 5$ ms, when simulated with a repetition interval of $t = 5$ ms.

The SCNT1 family of U-interface transceivers was upgraded to fully comply with this standard. The devices have been given an A suffix (T7234A, T7237A, and T7256A).

A proposal was added to the Living List (which is intended to collect issues and observations for a possible future update of ETSI ETR 080) to change the value of the microinterruption from 5 ms to 10 ms. The current SCNT1 family of U-interface transceivers (T7234A/T7237A/T7256A) from Lucent Technologies Microelectronics Group meets and exceeds this new requirement.

The above change to the SCNT1 family of transceivers has been fully verified, and test reports are available upon request.

Application Circuit

Please change the value of capacitor C15 from 0.1 μF to 1.0 μF in Figure 11 of the T7234 data sheet, Figure 17 of the T7237 data sheet, and Figure 20 of the T7256 data sheet. The following schematic shows the correct value (1.0 μF) for C15.

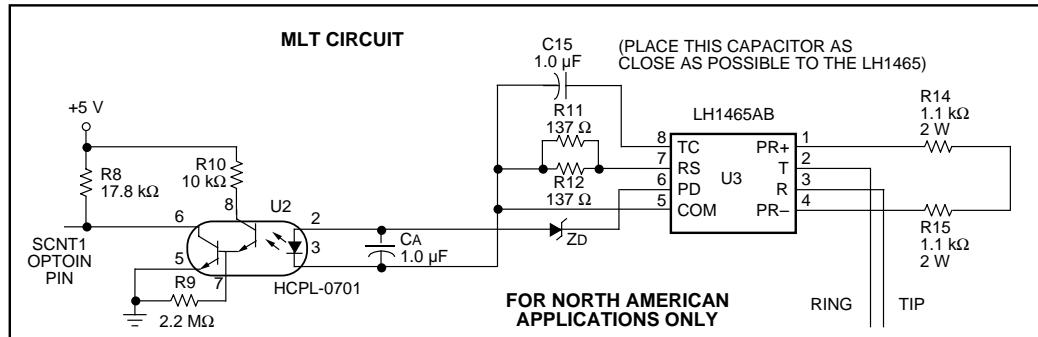

5-7034(C)

Figure 1. MLT Circuit Showing New Placement of Zener Diode (Z_D) and Capacitor (C_A)

In the ILOSS mode (refer to ANSI T1.601 1992, Section 6.5.2), the NT generates a scrambled, framed, 2B1Q signal such as SN1 and SN2. When the ILOSS mode is applied to circuits with the LH1465, it was observed that for some short loop lengths, the NT, once in the ILOSS mode, would not respond to further maintenance pulses until the ILOSS timer expired. It was discovered that there is some portion of the transmitted 2B1Q signal from the NT that passes through the LH1465 to the optoisolator. This causes the optoisolator to report incorrect dial pulses at its output, and thus prevent the NT from properly exiting the ILOSS mode.

To correct this situation, the dropout voltage (voltage at the Tip/Ring needed to turn on the optoisolator) of the optoisolator driver on the LH1465 is raised using the 3.6 V zener diode Z_D (for example, *Motorola** MMSZ4685T1). Capacitor C_A is a 1.0 μF $\pm 10\%$ tantalum chip capacitor, with a voltage rating of at least 16 V. C_A is added to provide a level of filtering for the transition points (turn-on or turn-off) of the optoisolator input voltage, which increases the robustness of the circuit.

* *Motorola* is a registered trademark of Motorola Inc.

For additional information, contact your Microelectronics Group Account Manager or the following:

INTERNET: <http://www.lucent.com/micro>
 E-MAIL: docmaster@micro.lucent.com
 N. AMERICA: Microelectronics Group, Lucent Technologies Inc., 555 Union Boulevard, Room 30L-15P-BA, Allentown, PA 18103
 1-800-372-2447, FAX 610-712-4106 (In CANADA: 1-800-553-2448, FAX 610-712-4106)
 ASIA PACIFIC: Microelectronics Group, Lucent Technologies Singapore Pte. Ltd., 77 Science Park Drive, #03-18 Cintech III, Singapore 118256
 Tel. (65) 778 8833, FAX (65) 777 7495
 CHINA: Microelectronics Group, Lucent Technologies (China) Co., Ltd., A-F2, 23/F, Zao Fong Universe Building, 1800 Zhong Shan Xi Road, Shanghai 200233 P. R. China Tel. (86) 21 6440 0468, ext. 316, FAX (86) 21 6440 0652
 JAPAN: Microelectronics Group, Lucent Technologies Japan Ltd., 7-18, Higashi-Gotanda 2-chome, Shinagawa-ku, Tokyo 141, Japan
 Tel. (81) 3 5421 1600, FAX (81) 3 5421 1700
 EUROPE: Data Requests: MICROELECTRONICS GROUP DATALINE: Tel. (44) 1189 324 299, FAX (44) 1189 328 148
 Technical Inquiries: GERMANY: (49) 89 95086 0 (Munich), UNITED KINGDOM: (44) 1344 865 900 (Bracknell),
 FRANCE: (33) 1 48 83 68 00 (Paris), SWEDEN: (46) 8 600 7070 (Stockholm), FINLAND: (358) 9 4354 2800 (Helsinki),
 ITALY: (39) 2 6601 1800 (Milan), SPAIN: (34) 1 807 1441 (Madrid)

Lucent Technologies Inc. reserves the right to make changes to the product(s) or information contained herein without notice. No liability is assumed as a result of their use or application. No rights under any patent accompany the sale of any such product(s) or information.





T7237 ISDN U-Interface Transceiver

Features

- U-interface for ISDN basic rate (2B+D) systems
 - Serial microprocessor and time-division multiplexed (TDM) bus interfaces
 - Automatic embedded operations channel (EOC) processing for ANSI T1.601 systems
 - Low power consumption (See Table 36, on page 65, Question and Answers section, for detailed power consumption information)
 - Idle-mode support (35 mW typical)
 - Automatic ANSI maintenance functions (quiet mode and insertion loss mode)
 - Conforms to ANSI T1.601 standard and ETSI ETR 080 technical report
 - 2B1Q four-level line code
 - Board-level testability support
- Serial microprocessor and TDM bus interfaces
 - Supports inexpensive serial microprocessor
 - Supports direct codec connection and voice/data ports
 - Allows access to 2B+D data on TDM bus
- Other
 - Single +5 V ($\pm 5\%$) supply
 - $-40\text{ }^{\circ}\text{C}$ to $+85\text{ }^{\circ}\text{C}$
 - 44-pin PLCC

Description

The Lucent Technologies Microelectronics Group T7237 ISDN U-Interface Transceiver is intended for use in ISDN U-interface terminal adapter (TA) equipment providing 2-wire termination of the network with B- and D-channel data available via a TDM interface.

The T7237 is a derivative of the T7256 device, and thus, its operation is essentially identical to the T7256, except for the absence of an S/T-interface. The T7237 conforms to the ANSI T1.601 standard and ETSI ETR 080 technical report for the U-interface. The single +5 V CMOS device is packaged in a 44-pin plastic leaded chip carrier (PLCC).

Table of Contents

Contents	Page
Features	1
Description	1
Pin Information	5
Application Overview	9
Functional Overview	10
U-Interface Frame Structure	10
Bit Assignments	11
U-Interface Description	12
Microprocessor Interface Description	13
Registers	13
Timing	27
Time-Division Multiplexed (TDM) Bus Description	29
Clock and Data Format	29
Frame Strobe	29
Data Flow Matrix Description	30
B1-, B2-, D-Channel Routing	30
Loopbacks	31
Modes of Operation	32
STLED Description	33
EOC State Machine Description	35
ANSI Maintenance Control Description	35
Board-Level Testing	35
External Stimulus/Response Testing	36
Application Briefs	37
T7237 Reference Circuit	37
Using the T7237 in a TA Environment	41
T7237 Configuration	41
Interfacing the T7237 to the Motorola 68302	43
Absolute Maximum Ratings	48
Handling Precautions	48
Recommended Operating Conditions	48
Electrical Characteristics	49
Power Consumption	49
Pin Electrical Characteristics	49
Crystal Characteristics	50
Timing Characteristics	51
Switching Test Input/Output Waveform	53
Outline Diagram	54
44-Pin PLCC	54
Ordering Information	54
Questions and Answers	55
Introduction	55
U-Interface	55
Miscellaneous	62
Glossary	67
Standards Documentation	71

Table of Contents (continued)

Figures	Page
Figure 1. Block Diagram	5
Figure 2. Pin Diagram.....	5
Figure 3. Applications of T7237	9
Figure 4. U-Interface Frame and Superframe	11
Figure 5. U-Interface Superframe Bit Groups	11
Figure 6. U-Interface Quat Example	12
Figure 7. Functional Register Map (Addresses)	13
Figure 8. Functional Register Map (Bit Assignments)	14
Figure 9. NEC and Motorola Microprocessor Port Connections.....	27
Figure 10. Intel Microprocessor Port Connections	27
Figure 11. Synchronous Microprocessor Port Interface Format.....	28
Figure 12. TDM Bus Time-Slot Format.....	30
Figure 13. B1-, B2-, D-Channel Routing.....	30
Figure 14. Location of the Loopback Configurations (Reference ITU-T I.430 Appendix I).....	31
Figure 15. STLED Control Flow Diagram	34
Figure 16. External Stimulus/Response Configuration	36
Figure 17. T7237 Reference Circuit	38
Figure 18. T7237 TA Application Block Diagram.....	41
Figure 19. MC68302 to T7237 Interface Diagram	43
Figure 20. T7237/MC68302 Interface Circuit.....	45
Figure 21. T7237/MC68302 Interface Timing	46
Figure 22. TDM Bus Timing.....	51
Figure 23. Timing Diagram Referenced to F	52
Figure 24. RESET Timing Diagram	52
Figure 25. Switching Test Waveform.....	53
Figure 26. Transceiver Impedance Limits	57

Table of Contents (continued)

Tables	Page
Table 1. Pin Descriptions	6
Table 2. U-Interface Bit Assignment	11
Table 3. Global Device Control—Device Configuration (Address 00h)	15
Table 4. Global Device Control—U-Interface (Address 01h)	16
Table 5. Global Device Control (Address 02h)	17
Table 6. Data Flow Control—U and S/T B Channels (Address 03h)	18
Table 7. Data Flow Control—D Channels and TDM Bus (Address 04h)	18
Table 8. TDM Bus Timing Control (Address 05h)	19
Table 9. Control Flow State Machine Control—Maintenance/Reserved Bits (Address 06h)	20
Table 10. Control Flow State Machine Status (Address 07h)	21
Table 11. Control Flow State Machine Status—Reserved Bits (Address 08h)	21
Table 12. EOC State Machine Control—Address (Address 09h)	22
Table 13. EOC State Machine Control—Information (Address 0Ah)	23
Table 14. EOC State Machine Status—Address (Address 0Bh)	23
Table 15. EOC State Machine Status—Information (Address 0Ch)	23
Table 16. U-Interface Interrupt Register (Address 0Dh)	24
Table 17. U-Interface Interrupt Mask Register (Address 0Eh)	25
Table 18. Maintenance Interrupt Register (Address 0Fh)	25
Table 19. Maintenance Interrupt Mask Register (Address 10h)	26
Table 20. Global Interrupt Register (Address 11h)	26
Table 21. Microprocessor Mode	32
Table 22. STLED States	33
Table 23. T7237 Reference Schematic Parts List	39
Table 24. Line-Side Resistor Requirements	40
Table 25. Motorola MC68302 SCC Options	43
Table 26. Channel Selection Criteria	44
Table 27. Power Consumption	49
Table 28. Digital dc Characteristics (Over Operating Ranges)	49
Table 29. Fundamental Mode Crystal Characteristics	50
Table 30. Internal PLL Characteristics	50
Table 31. TDM Bus Timing	51
Table 32. Clock Timing	52
Table 33. RESET Timing	52
Table 34. Power Dissipation Variation	64
Table 35. Power Dissipation of CKOUT	64
Table 36. Power Consumption	65

Description (continued)

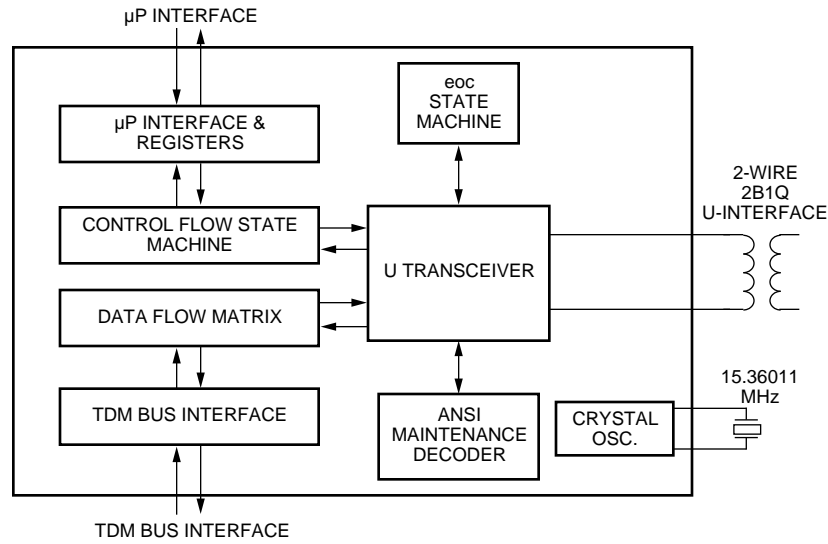

5-2292.b (C)

Figure 1. Block Diagram

Pin Information

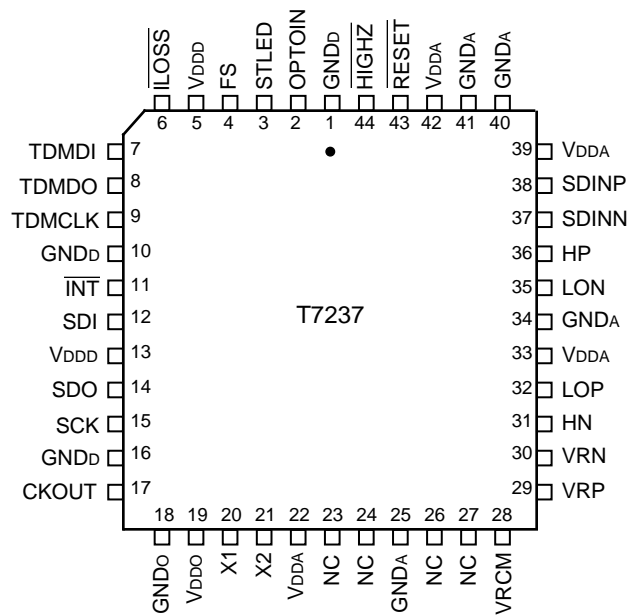

5-2296.b (C)

Figure 2. Pin Diagram

Pin Information (continued)

Table 1. Pin Descriptions

Pin	Symbol	Type*	Name/Function
1, 10, 16	GND _D	—	Digital Ground. Ground leads for digital circuitry.
2	OPTOIN	I ^u	Optoisolator Input. Pin accepts CMOS logic level maintenance pulse streams. These pulse streams typically are generated by an optoisolator that is monitoring the U loop. Pulse patterns on this pin are digitally filtered for 20 ms before being considered valid and are then decoded and interpreted using the ANSI maintenance state machine requirements. If AUTOCTL = 1 (register GR0, bit 3, default), the internal state machine decodes pulse trains and implements the required maintenance states automatically. If AUTOCTL = 0, the pulse trains are decoded internally, but the microprocessor must implement the maintenance state as indicated by the maintenance interrupts (register MIRQ). If the OPTOIN pin is being used for implementing maintenance functions, the ILOSS pin should not be used (i.e., it should be held high). Instead, the ILOSS register bit should be used (register CFR0, bit 0). An internal 100 kΩ pull-up resistor is on this pin.
3	STLED	O	Status LED Driver. Output pin for driving an LED (source/sink 4.0 mA) that indicates the device status. The four defined states are low, high, 1 Hz flashing, and 8 Hz flashing (flashing occurs at 50% duty cycle). See the STLED Description section for a detailed explanation of these states. Also, this pin indicates device sanity upon power-on/RESET, as follows: <ul style="list-style-type: none"> ■ If SCK = 0 (pin 15) after a device RESET (which sets AUTOACT = 0 in register GR0 bit 6, turning on autoactivation), STLED will toggle at an 8 Hz rate for at least 0.5 s, signifying an activation attempt. If the activation attempt succeeds, it will continue to flash per the normal start-up sequence (see STLED Description section). ■ If SCK = 1 (pin 15) after a device RESET, STLED will go low for 1 s (flash of life), indicating that the device is operational, and no activation attempt will be made.
4	FS	O	Frame Strobe. If TDMEN = 0 (register GR2, bit 5), this pin is a programmable strobe output used to indicate appearance of B- and/or D-channel data on the TDM bus. Polarity, offset, and duration of FS are programmable through the microprocessor interface (see register TDR0).
5, 13	V _{DDD}	—	Digital Power. 5 V ± 5% power supply pins for digital circuitry.
6	ILOSS	I ^u	Insertion Loss Test Control (Active-Low). The ILOSS pin is used to control SN1 tone transmission for maintenance. The OPTOIN and ILOSS pins should not be used at the same time (i.e., OPTOIN should be held high when ILOSS is active). This pin would typically be used if an external ANSI maintenance decoder is being used, in which case the decoder output drives the ILOSS pin. The ILOSS pin is ignored, and the functionality is controlled by the ILOSS bit (register CFR0, bit 0) if AUTOCTL = 0 (register GR0, bit 3). Internal 100 kΩ pull-up resistor on this pin. 0—U transmitter sends SN1 tone continuously. 1—No effect on device operation.

* I^u = input with internal pull-up.

Pin Information (continued)

Table 1. Pin Descriptions (continued)

Pin	Symbol	Type*	Name/Function
7	TDMDI	I ^u	TDM Data In. If TDMEN = 0 (register GR2, bit 5), this pin is the TDM bus 2B+D data input synchronous with TDMCLK. An internal 100 kΩ pull-up resistor is on this pin.
8	TDMDO	O	TDM Data Out. If TDMEN = 0, this pin is the 2.048 MHz TDM bus 2B+D data output synchronous with TDMCLK.
9	TDMCLK	O	TDM Clock. If TDMEN = 0, this pin is the 2.048 MHz TDM clock output synchronous with U-interface (if active) or is free-running.
11	INT	O	Serial Interface Microprocessor Interrupt (Active-Low). Interrupt output for microprocessor. Any active, unmasked bit in interrupt registers UIR0 or MIR0 will cause INT to go low. The bits in the interrupt registers UIR0 and MIR0 will be set on a true condition, independent of the state of the corresponding mask bits. If a masked, active interrupt bit is subsequently unmasked, the INT pin will go low to indicate an interrupt for that condition. Reading UIR0 or MIR0 clears the entire register and forces INT high for 50 μs. After this interval, INT will again reflect the state of any unmasked bit in these registers. The global interrupt register (GIRO) provides a summary status of the UIR0 and MIR0 interrupt registers and indicates if one of the registers currently has an active, unmasked interrupt bit.
12	SDI	I ^d	Serial Interface Data Input. Data input for microprocessor interface.
14	SDO	O	Serial Interface Data Output. Data output for microprocessor interface. This pin is 3-stated at all times except for when a microprocessor read from the T7237 is taking place.
15	SCK	I ^d	Serial Interface Clock. Clock input for microprocessor interface.
17	CKOUT	O	Clock Output. Clock output function to drive other board components. Powerup default state is high impedance to minimize power consumption. Programmable via microprocessor register (register GR0, bits 1 and 2) to provide 15.36 MHz output or 10.24 MHz output. If U-interface is active, the 10.24 MHz output is synchronous with U-interface timing.
18	GND _O	—	Crystal Oscillator Ground. Ground lead for crystal oscillator.
19	V _{DDO}	—	Crystal Oscillator Power. Power supply lead for crystal oscillator.
20	X1	O	Crystal #1. Crystal connection #1 for 15.36 MHz oscillator.
21	X2	I	Crystal #2. Crystal connection #2 for 15.36 MHz oscillator.

* I^u = input with internal pull-up; I^d = input with internal pull-down.

Pin Information (continued)

Table 1. Pin Description (continued)

Pin	Symbol	Type*	Name/Function
22, 33, 39, 42	V _{DDA}	—	Analog Power. 5 V ± 5% power supply leads for analog circuitry.
23	NC	O	No Connect. Do not use as a tie point.
24	NC	O	No Connect. Do not use as a tie point.
25, 34, 40, 41	GND _A	—	Analog Ground. Ground leads for analog circuitry.
26	NC	I	No Connect. Do not use as a tie point.
27	NC	I	No Connect. Do not use as a tie point.
28	VRCM	—	Common-Mode Voltage Reference for U-Interface Circuits. Connect a 0.1 μF ± 20% capacitor to GND _A (as close to the device pins as possible).
29	VRP	—	Positive Voltage Reference for U-Interface Circuits. Connect a 0.1 μF ± 20% capacitor to GND _A (as close to the device pins as possible).
30	VRN	—	Negative Voltage Reference for U-Interface Circuits. Connect a 0.1 μF ± 20% capacitor to GND _A (as close to the device pins as possible).
31	HN	I	Hybrid Negative Input for U-Interface. Connect directly to negative side of U-interface transformer.
32	LOP	O	Line Driver Positive Output for U-Interface. Connect to the U-interface transformer through a 16.9 Ω ± 1% resistor.
35	LON	O	Line Driver Negative Output for U-Interface. Connect to the U-interface transformer through a 16.9 Ω ± 1% resistor.
36	HP	I	Hybrid Positive Input for U-Interface. Connect directly to positive side of U-interface transformer.
37	SDINN	I	Sigma-Delta A/D Negative Input for U-Interface. Connect via an 820 pF ± 5% capacitor to SDINP.
38	SDINP	I	Sigma-Delta A/D Positive Input for U-Interface. Connect via an 820 pF ± 5% capacitor to SDINN.
43	RESET	I ^d	Reset (Active-Low). Asynchronous Schmitt trigger input. Reset halts data transmission, clears adaptive filter coefficients, resets the U-transceiver timing recovery circuitry, and sets all microprocessor register bits to their default state. During reset, the U-interface transmitter produces 0 V and the output impedance is 135 Ω at tip and ring. The RESET pin can be used to implement quiet mode maintenance testing (refer to pin 2 for more description). The states of pins 11, 12, and 15 (INT, SDI, and SCK, respectively) are latched on the rising edge of RESET. (See corresponding pin descriptions.) An internal 100 kΩ pull-down resistor is on this pin. RESET must be held low for 1.5 ms after power-on. Device is fully functional after an additional 1 ms.
44	HIGHZ	I ^u	High-Impedance Control (Active-Low). Control of the high-impedance function. An internal 100 kΩ pull-up resistor is on this pin. Note: This pin does not 3-state the analog outputs. 0—All digital outputs enter high-impedance state. 1—No effect on device operation.

* I^u = input with internal pull-up; I^d = input with internal pull-down.

Application Overview

The T7237 is intended for use in ISDN networks as part of a terminal adapter (TA), providing 2-wire termination of the network with available voice and/or data ports. The 2B+D data is accessible by the TDM highway, and the device is configured using the serial microprocessor interface. Figure 3 shows the TA application.

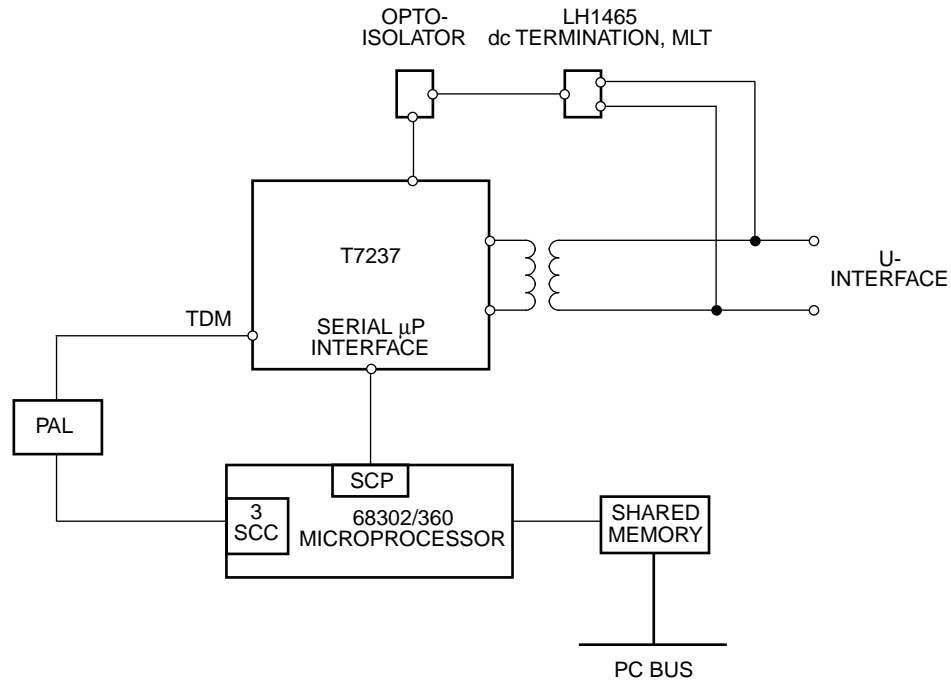

5-4416 (F)

Figure 3. Applications of T7237

Functional Overview

The T7237 device provides three major interfaces for information transfer: the U-interface, the microprocessor interface, and the time-division multiplexed (TDM) bus interface (see Figure 1).

The architecture of the T7237 allows for a flexible combination of automatically and manually controlled functions. A control flow state machine and an EOC state machine can be independently enabled or disabled. When enabled, these circuit blocks automatically perform their functions while ignoring the associated control bits in the microprocessor registers. When disabled, the control bits are made available to the microprocessor for manipulation. At all times, the status bits are available to the microprocessor and the 2B+D data can be routed via the data flow matrix.

The microprocessor interface is a serial communications port consisting of input data (SDI), output data (SDO), input clock (SCK), and an output interrupt pin ($\overline{\text{INT}}$). The microprocessor interface supports synchronous communication between the T7237 and an inexpensive microprocessor with a serial port. The interrupt is maskable via the onboard microprocessor interrupt mask registers. The internal register set controls various functions including information routing between interfaces, auto-EOC processing, maintenance testing, microprocessor interrupt masks, activation of the TDM bus, and frame strobe timing.

The TDM interface consists of a TDM bus data clock (TDMCLK), input data (TDMDI), output data (TDMDO), and frame strobe (FS). The 2B+D data is transmitted and received in fixed time slots on the TDM bus; however, the frame strobe output lead is programmable to support a wide variety of devices (codecs, HDLC processors, asynchronous interfaces) for direct connection on the TDM bus. When the TDM bus is activated, pins 4, 7, 8, and 9 form the bus interface.

The EOC state machine, when enabled, automatically performs the EOC channel functions as described in the ANSI requirements. When disabled, control of the EOC channel is passed to the microprocessor via the appropriate microprocessor register bits.

The ANSI maintenance controller can operate in fully automatic or in fully manual mode. In automatic mode, the device decodes and responds to maintenance states according to the ANSI requirements. In manual mode, the device is controlled by an external maintenance decoder that drives the $\overline{\text{RESET}}$ and $\overline{\text{ILOSS}}$ pins to implement the required maintenance states.

The control flow state machine performs the functions of reserved bit insertion, automatic implementation of the ANSI maintenance state machine, and automatic prioritization of multiple requests, such as reset, activation, maintenance, etc. Some bits that are normally controlled by the control flow state machine can be forced to their active state by writing the appropriate register (i.e., register GR1). When the control flow state machine is disabled (via the AUTOCTL bit in register GR0), the only change in the operation is that reserved bit control and ANSI maintenance control are passed directly to the microprocessor via register CFR0.

When the T7237 is powered on and there is no activity on the U-interfaces (i.e., no pending activation request), it automatically enters a low-power IDLE mode in which it consumes an average of 35 mW.

This mode is exited automatically when an activation or U maintenance request occurs from either the microprocessor or the U-interfaces. The T7237 provides a board-level test capability that allows functional verification. Finally, an LED driver output indicates the status of the device during operation.

U-Interface Frame Structure

Data is transmitted over the U-interface in 240-bit groups called U frames. Each U frame consists of an 18-bit synchronization word or inverted synchronization word (SW or ISW), 12 blocks of 2B+D data (216 bits), and six overhead bits (M bits). A U-interface superframe consists of eight U frames grouped together. The beginning of a U superframe is indicated by the inverted sync word (ISW). The six overhead bits (M1—M6) from each of the eight U frames, when taken together, form the 48 M bits. Figure 4 shows how U frames, superframes, and M bits are arranged.

Of the 48 M bits, 24 bits form the embedded operations channel (EOC) for sending messages from the LT to the NT and responses from the NT to the LT. There are two EOC messages per superframe with 12 bits per EOC message (EOC1 and EOC2). Another 12 bits serve as U-interface control and status bits (UCS). The last 12 bits form the cyclic redundancy check (CRC) which is calculated over the 2B+D data and the M4 bits of the previous superframe. Figure 4 and Table 2 show the different groups of bits in the superframe.

U-Interface Frame Structure (continued)

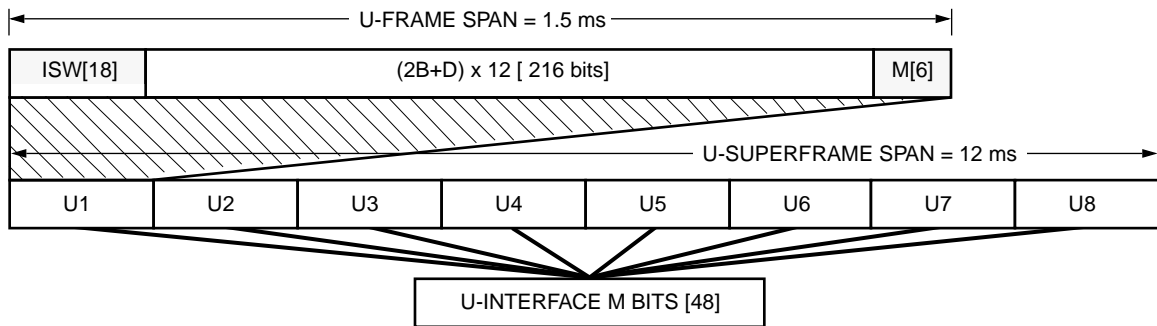

5-2476 (C)

Figure 4. U-Interface Frame and Superframe

Bit #	1—18	19—234	235	236	237	238	239	240
Frame #	Sync	12(2B+D)	M1	M2	M3	M4	M5	M6
1	ISW	2B+D	EOC1			CONTROL & STATUS (UCS)		
2	SW		EOC2					
3			crc					
4								
5								
6								
7								
8								

Figure 5. U-Interface Superframe Bit Groups

Bit Assignments

Table 2. U-Interface Bit Assignment

Bit #	1—18	19—234	235	236	237	238	239	240
Frame #	Sync	12(2B+D)	M1	M2	M3	M4	M5	M6
1	ISW	2B+D	EOC _{a1}	EOC _{a2}	EOC _{a3}	act	R _{1, 5}	R _{1, 6}
2	SW	2B+D	EOC _{dm}	EOC _{i1}	EOC _{i2}	dea (ps1)*	R _{2, 5}	febe
3	SW	2B+D	EOC _{i3}	EOC _{i4}	EOC _{i5}	R _{3, 4} (ps2)*	crc1	crc2
4	SW	2B+D	EOC _{i6}	EOC _{i7}	EOC _{i8}	R _{4, 4} (ntm)*	crc3	crc4
5	SW	2B+D	EOC _{a1}	EOC _{a2}	EOC _{a3}	R _{5, 4} (cso)*†	crc5	crc6
6	SW	2B+D	EOC _{dm}	EOC _{i1}	EOC _{i2}	R _{6, 4}	crc7	crc8
7	SW	2B+D	EOC _{i3}	EOC _{i4}	EOC _{i5}	uoa (sai)*	crc9	crc10
8	SW	2B+D	EOC _{i6}	EOC _{i7}	EOC _{i8}	aib (nib)*‡	crc11	crc12

* LT(NT). Values in parentheses () indicate meaning at the NT.

† cso is fixed at 0 by the device to indicate both cold- and warm-start capability.

‡ nib is fixed at 1 by the device to indicate the link is normal.

U-Interface Description

At the U-interface, the T7237 conforms to ANSI T1.601 and ETSI ETR 080 when used with the proper line interface circuitry. The T7237 Reference Circuit description in the Application Briefs section of this document describes a detailed example of a U-interface circuit design.

The 2B1Q line code provides a four-level (quaternary) pulse amplitude modulation code with no redundancy. Data is grouped into pairs of bits for conversion to quaternary (quat) symbols. Figure 6 shows an example of this coding method.

The U-interface transceiver section provides the 2B1Q line coder (D/A conversion), pulse shaper, line driver, first-order line balance network, clock regeneration, and sigma-delta A/D conversion. The line driver, when connected to the proper transformer and interface circuitry, generates pulses which meet the required 2B1Q templates. The A/D converter is implemented by using a double-loop, sigma-delta modulator.

The U transceiver block also takes input from the data flow matrix and formats this information for the U-interface (see Figure 1). During this formatting, synchronization bits for U framing are added and a scrambling algorithm is applied. This data is then transferred to the 2B1Q encoder for transmission over the U-interface.

Signals received from the U-interface are first passed through the sigma-delta A/D converter, and then sent to the digital signal processor for more extensive signal processing. The block provides decimation of the sigma-delta output, linear and nonlinear echo cancellation, automatic gain control, signal detection, phase shift interpolation, decision feedback equalization, timing recovery, descrambling, and line-code polarity detection. The decision feedback equalizer circuit provides the functionality necessary for proper operation on subscriber loops with bridged taps.

A crystal oscillator provides the 15.36 MHz master clock for the device. The on-chip, phase-locked loop provides the ability to synchronize the chip to the line rate.

The U-interface provides rapid cold-start and warm-start operation. From a cold-start, the device is typically operational within four seconds. The interface supports activation/deactivation, and when properly deactivated, it stores the adaptive filter coefficients permitting a warm-start on the next activation request. A warm-start typically requires 200 ms for the device to become operational.

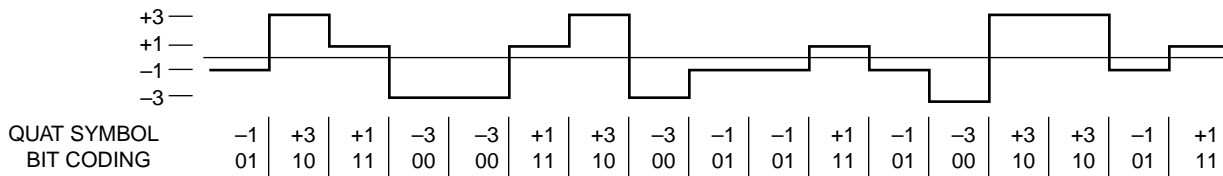

5-2294 (C)

Figure 6. U-Interface Quat Example

Microprocessor Interface Description

The microprocessor interface, used to control and monitor the device, is compatible with most general-purpose serial microprocessor interfaces using a synchronous mode of transmission. Transmission from the microprocessor to the T7237 occurs in a 2-byte format, the first byte representing read/write and register address command information and the second byte being write data or don't cares for a read operation. Transmission from the T7237 to the microprocessor carries register data only. The interrupt line to the microprocessor is maskable and can be used to signal the microprocessor to initiate a register read or write operation. A more detailed description of the operation follows, and detailed timing information is given in the Timing Characteristics section.

Registers

The on-chip registers are divided by major circuit block and by status and control function. Microprocessor register control bits associated with the control flow state machine, EOC state machine, and multiframing controller are ignored when those blocks are enabled (the device controls the blocks automatically). When the blocks are disabled, the control bits are used to drive device operations. The functional summary of the registers and bits is shown in Figure 7 and Figure 8.

ADDRESS			
00000	GR0	R/W	GLOBAL DEVICE CONTROL — DEVICE CONFIGURATION
00001	GR1	R/W	GLOBAL DEVICE CONTROL — U-INTERFACE
00010	GR2	R/W	GLOBAL DEVICE CONTROL
00011	DFR0	R/W	DATA FLOW CONTROL — U B CHANNELS
00100	DFR1	R/W	DATA FLOW CONTROL — D CHANNELS & TDM BUS
00101	TDR0	R/W	TDM BUS TIMING CONTROL
00110	CFR0	R/W	CONTROL FLOW SM CONTROL — MAINTEN./RSV. BITS
00111	CFR1	R	CONTROL FLOW SM STATUS
01000	CFR2	R	CONTROL FLOW SM STATUS — RESERVED BITS
01001	ECR0	R/W	eoc STATE MACHINE CONTROL — ADDRESS
01010	ECR1	R/W	eoc STATE MACHINE CONTROL — INFORMATION
01011	ECR2	R	eoc STATE MACHINE STATUS — ADDRESS
01100	ECR3	R	eoc STATE MACHINE STATUS — INFORMATION
10011	UIR0	R	U-INTERFACE INTERRUPT REGISTER
10100	UIR1	R/W	U-INTERFACE INTERRUPT MASK REGISTER
10111	MIR0	R	MAINTENANCE INTERRUPT REGISTER
11000	MIR1	R/W	MAINTENANCE INTERRUPT MASK REGISTER
11001	GIR0	R	GLOBAL INTERRUPT REGISTER

5-2299.a (C)

Figure 7. Functional Register Map (Addresses)

Microprocessor Interface Description (continued)

Registers (continued)

REG	R/W	BIT 7	BIT 6	BIT 5	BIT 4	BIT 3	BIT 2	BIT 1	BIT 0
GR0	R/W	RESERVED	AUTOACT	—	AUTOEOC	AUTOCTL	CRATE1	CRATE0	RESET
GR1	R/W	SAI1	SAI0	XPCY	ACTT	NTM	PS1	PS2	LPBK
GR2	R/W	—	ACTSEL	TDMEN	U2BDLN	—	—	—	—
DFR0	R/W	—	—	—	—	UXB21	UXB20	UXB11	UXB10
DFR1	R/W	TDMDU	TDMB2U	TDMB1U	—	—	—	—	UXD
TDR0	R/W	—	—	—	—	FSP	FSC2	FSC1	FSC0
CFR0	R/W	—	—	R64T	R25T	R16T	R15T	AFRST	ILOSS
CFR1	R	—	AIB	FEBE	NEBE	UOA	OOF	XACT	ACTR
CFR2	R	—	R64R	R54R	R44R	R34R	R15R	R16R	R15R
ECR0	R/W	CCRC	U2BDLT	UB2LP	UB1LP	DMT	A1T	A2T	A3T
ECR1	R/W	I1T	I2T	I3T	I4T	I5T	I6T	I7T	I8T
ECR2	R	—	—	—	—	DMR	A1R	A2R	A3R
ECR3	R	I1R	I2R	I3R	I4R	I5R	I6R	I7R	I8R
UIR0	R	—	—	TSFINT	RSFINT	OUSC	BERR	ACTSC	EOCSC
UIR1	R/W	—	—	TSFINTM	RSFINTM	OUSCM	BERRM	ACTSCM	EOCSCM
MIR0	R	—	—	—	—	—	EMINT	ILINT	QMINT
MIR1	R/W	—	—	—	—	—	EMINTM	ILINTM	QMINTM
GIR0	R	—	—	—	—	—	MINT	—	UINT

5-2483.a (C)

Figure 8. Functional Register Map (Bit Assignments)

Microprocessor Interface Description (continued)

Registers (continued)

Table 3. Global Device Control—Device Configuration (Address 00h)

Reg	R/W	Bit 7	Bit 6	Bit 5	Bit 4	Bit 3	Bit 2	Bit 1	Bit 0
GR0	R/W	RES	AUTOACT	—	AUTOEOC	AUTOCTL	CRATE1	CRATE0	RESET
Default State on $\overline{\text{RESET}}$		1	SCK	1	1	1	1	1	1

Register	Bit	Symbol	Name/Description
GR0	0	RESET	Reset. Same function as external $\overline{\text{RESET}}$ pin, except the state of the SCK, $\overline{\text{INT}}$, and SDI pins are not checked. Assertion of this bit halts data transmission, clears adaptive filter coefficients, and sets all microprocessor register bits (except itself) to their default state. The microprocessor must write this bit back to a 1 to bring the T7237 out of its RESET state. During reset, the U-interface transmitter produces 0 V and the output impedance is 135 Ω at tip and ring. 0—Reset. 1—No effect on device operation (default).
GR0	2—1	CRATE[1:0]	CKOUT Rate Control. 00—Not used. 01—10.24 MHz synchronous with U-interface (if active); otherwise, free-running. 10—15.36 MHz free-running. 11—3-state (default).
GR0	3	AUTOCTL	Auto Control Enable. Enables automatic control of ANSI maintenance and reserved bit insertion. When AUTOCTL = 1, register CFR0 is ignored and the control flow state machine automatically controls ANSI maintenance functions and reserved bit insertion. When AUTOCTL = 0, the microprocessor controls ANSI maintenance functions and reserved bit insertion via register CFR0. 0—CFR0 functions controlled manually by microprocessor. 1—CFR0 functions controlled automatically.
GR0	4	AUTOEOC	Automatic EOC Processor Enable. Enables EOC state machine which implements EOC processing per the ANSI standard. When AUTOEOC = 1, registers ECR0—ECR1 are ignored. The EOC state machine only responds to addresses 000 and 111 as valid addresses. 0—EOC state machine disabled. 1—EOC state machine enabled (default).
GR0	6	AUTOACT	Automatic Activation Control. Upon a 1-to-0 transition of the AUTOACT bit, the control flow state machine attempts one activation of the U-interface. After the activation attempt, this bit is internally set to 1, automatically. If the SCK pin is low on the rising edge of $\overline{\text{RESET}}$, AUTOACT is written to 0 and one activation attempt is made (see SCK pin description in Table 1). Multiple activation attempts can be made by repeatedly writing 0s to this bit. 1—No activation attempt. 0—One activation attempt.
GR0	7	—	Reserved. Set to 1. 1—Default.

Microprocessor Interface Description (continued)**Registers** (continued)**Table 4. Global Device Control—U-Interface (Address 01h)**

Reg	R/W	Bit 7	Bit 6	Bit 5	Bit 4	Bit 3	Bit 2	Bit 1	Bit 0
GR1	R/W	SAI1	SAI0	XPCY	ACTT	NTM	PS1	PS2	LPBK
Default State on RESET		1	1	1	0	1	1	1	1

Register	Bit	Symbol	Name/Description															
GR1	0	LPBK	U-Interface Analog Loopback. Controls loopback of U-interface data stream at the line interface. Loopback turns off the echo canceler and reconfigures the receive scrambler to match the transmit scrambler. The line should be disconnected before this loopback test. This ensures that a sufficiently large echo is generated so that the device can detect the echo as received data and synchronize to it. 0—U-interface analog loopback. 1—No effect on device operation (default).															
GR1	1	PS2	Power Status #2. Controls PS2 bit in transmit U-interface data stream if TDMEN = 0 (register GR2, bit 5). If TDMEN = 1, PS2 bit is ignored. For ANSI T1.601 applications, PS1 and PS2 indicate the NT power status via the following messages: <table border="1"> <thead> <tr> <th>PS1</th> <th>PS2</th> <th>Power Status</th> </tr> </thead> <tbody> <tr> <td>0</td> <td>0</td> <td>Dying gasp.</td> </tr> <tr> <td>0</td> <td>1</td> <td>Primary power out.</td> </tr> <tr> <td>1</td> <td>0</td> <td>Secondary power out.</td> </tr> <tr> <td>1</td> <td>1</td> <td>All power normal (default).</td> </tr> </tbody> </table>	PS1	PS2	Power Status	0	0	Dying gasp.	0	1	Primary power out.	1	0	Secondary power out.	1	1	All power normal (default).
PS1	PS2	Power Status																
0	0	Dying gasp.																
0	1	Primary power out.																
1	0	Secondary power out.																
1	1	All power normal (default).																
GR1	2	PS1	Power Status #1. Controls PS1 bit in transmit U-interface data stream if TDMEN = 0 (register GR2, bit 5). If TDMEN = 1, PS1 bit is ignored. See PS2 bit definition.															
GR1	3	NTM	NT Test Mode. Controls ntm bit in transmit U-interface data stream and indicates if the NT is in a customer-initiated test mode. 0—NT is currently in a customer-initiated test mode. 1—No effect on device operation (default).															
GR1	4	ACTT	Transmit Activation. Controls act bit in transmit U-interface data stream. 0—No effect on device operation (default). 1—Ready to transmit.															
GR1	5	XPCY	Transparency. Controls data being transmitted at U-interface. 0—Enable data transparency. 1—No effect on device operation (default).															
GR1	7—6	SAI[1:0]	S/T-Interface Activity Indicator Control. Controls sai bit in transmit U-interface data stream. For ANSI T1.601 applications, the sai bit is set to 1 to indicate to the network that there is activity (INFO 1 or INFO 3) at the S/T reference point. Since some switch software expects to see sai = 1 before establishing layer 1 transparency, it is good practice to force sai = 1 in U-terminal adapter applications to emulate the presence of a TE. The SAI[1:0] bits provide the following options for controlling the sai bit: 00—Forces sai to 0 on the U-interface. 01—Forces sai to 1 on the U-interface. 11—Forces sai to 0 on the U-interface.															

Microprocessor Interface Description (continued)

Registers (continued)

Table 5. Global Device Control (Address 02h)

Reg	R/W	Bit 7	Bit 6	Bit 5	Bit 4	Bit 3	Bit 2	Bit 1	Bit 0
GR2	R/W	—	ACTSEL	TDMEN	U2BDLN	—	—	—	—
Default State on $\overline{\text{RESET}}$		1	ACTMODE/ INT pin	1	1	1	1	1	1

Register	Bit	Symbol	Name/Description
GR2	4	U2BDLN	<p>Nontransparent 2B+D Loopback Control. When 0, this bit causes a nontransparent loopback of 2B+D data from U receiver to U transmitter upstream of the data flow matrix. Note that this loopback path is not as close to the S/T-interface as the transparent loopback initiated by U2BDLT (register ECR0, bit 6). This loopback may be useful for test purposes. When this bit is set, the upstream data (NT to LT direction) will be forced to all 1s until either ACTR = 1 (register CFR1, bit 0) or XPCY = 0 (register GR1, bit 5).</p> <p>0—2B+D loopback. All 1s 2B+D data is automatically generated towards the TE.</p> <p>1—No loopback (default).</p>
GR2	5	TDMEN	<p>TDM Bus Select. Selects functions of pins 4, 7, 8, and 9.</p> <p>0—TDM bus functions. Pins 4, 7, 8, and 9 configured as FS, TDMDI, TDMDO, and TDMCLK, respectively. See DFR1 and TDR0 registers for TDM bus programming details. Microprocessor register bits GR11, GR12, and GR20 control the PS2, PS1, and FT functions.</p> <p>1—No TDM bus. Pins 4, 7, 8, and 9 configured as SYN8K/LBIND, FTE, PS2E, and PS1E, respectively (default).</p>
GR2	6	ACTSEL	<p>ACT Mode Select. Controls the state of the transmitted ACT bit when an EOC loopback 2 (2B+D loopback) is requested. The loopback 2 occurs automatically if AUTOEOC = 1 (register GR0, bit 4). Otherwise, bit U2BDLT (register ECR0, bit 6) must be set to 0. The initial state of ACTSEL is determined by the state of the ACTMODE/$\overline{\text{INT}}$ pin on the rising edge of $\overline{\text{RESET}}$.</p> <p>0—act = 0 during loopback 2 (per ANSI T1.601). The data received at the NT is looped back towards the LT as soon as the 2B+D loopback is enabled.</p> <p>1—act = 1 during loopback 2 (per ETSI ETR 080). The data received by the NT is not looped back towards the LT until after ACT = 1 is received from the LT. Prior to this time, 2B+D data toward the LT is all 1s.</p>

Microprocessor Interface Description (continued)**Registers** (continued)**Table 6. Data Flow Control—U and S/T B Channels (Address 03h)**

Reg	R/W	Bit 7	Bit 6	Bit 5	Bit 4	Bit 3	Bit 2	Bit 1	Bit 0
DFR0	R/W	—	—	—	—	UXB21	UXB20	UXB11	UXB10
Default State on $\overline{\text{RESET}}$		1	1	1	1	1	1	1	1

Register	Bit	Symbol	Name/Description
DFR0	1—0	UXB1[1:0]	U-Interface Transmit Path Source for B1 Channel. Refer to point #1 in Figure 13. 00—Not used. 01—TDM bus. 10—All 1s. 11—Not used.
DFR0	3—2	UXB2[1:0]	U-Interface Transmit Path Source for B2 Channel. Refer to point #1 in Figure 13. 00—Not used. 01—TDM bus. 10—All 1s. 11—Not used.

Table 7. Data Flow Control—D Channels and TDM Bus (Address 04h)

Bits 2—7 are enabled only if TDMEN = 0 (register GR2, bit 5). The TDMCLK and FS outputs are activated if any one of bits 2—7 is enabled. The TDMDO output is activated during time slots enabled by programming bits 2—7.

Reg	R/W	Bit 7	Bit 6	Bit 5	Bit 4	Bit 3	Bit 2	Bit 1	Bit 0
DFR1	R/W	TDMDU	TDMB2U	TDMB1U	—	—	—	—	UXD
Default State on $\overline{\text{RESET}}$		1	1	1	1	1	1	1	1

Register	Bit	Symbol	Name/Description
DFR1	0	UXD	U-Interface Transmit Path Source for D Channel. Refer to point #1 in Figure 13. 0—TDM bus. 1—Reserved.
DFR1	5	TDMB1U	TDM Bus Transmit Control for B1 Channel from U-Interface. Refer to point #2 in Figure 13. Controls transmit time slot allocated on TDM bus for B1 channel derived from U-interface receiver. 0—Time slot enabled. 1—Time slot disabled (high impedance) (default).
DFR1	6	TDMB2U	TDM Bus Transmit Control for B2 Channel from U-Interface. Refer to point #2 in Figure 13. Controls transmit time slot allocated on TDM bus for B2 channel derived from U-interface receiver. 0—Time slot enabled. 1—Time slot disabled (high impedance) (default).
DFR1	7	TDMDU	TDM Bus Transmit Control for D Channel from U-Interface. Refer to point #2 in Figure 13. Controls transmit time slot allocated on TDM bus for D channel derived from U-interface receiver. 0—Time slot enabled. 1—Time slot disabled (high impedance) (default).

Microprocessor Interface Description (continued)

Registers (continued)

Table 8. TDM Bus Timing Control (Address 05h)

Bits 0—4 are enabled only if TDMEN = 0 (register GR2, bit 5) and one or more of bits DFR1[2:7] are set to 0.

Reg	R/W	Bit 7	Bit 6	Bit 5	Bit 4	Bit 3	Bit 2	Bit 1	Bit 0
TDR0	R/W	—	—	—	—	FSP	FSC2	FSC1	FSC0
Default State on RESET		—	—	—	—	1	1	1	1

Register	Bit	Symbol	Name/Description
TDR0	2—0	FSC[2:0]	<p>Frame Strobe (FS) Control. Selects location of strobe envelope within TDM bus time slots.</p> <p>000—Reserved. 001—U-interface 2B+D channel strobe (18-bit envelope). 010—Reserved. 011—U-interface B2 channel strobe (8-bit envelope). 100—Reserved. 101—U-interface D channel strobe (2-bit envelope). 110—Reserved. 111—U-interface B1 channel strobe (8-bit envelope) (default).</p>
TDR0	3	FSP	<p>Frame Strobe (FS) Polarity.</p> <p>0—Active-low envelope. 1—Active-high envelope (default).</p>

Microprocessor Interface Description (continued)**Registers** (continued)**Table 9. Control Flow State Machine Control—Maintenance/Reserved Bits (Address 06h)**

This register has no effect on device operation if AUTOCTL = 1 (register GR0, bit 3).

Reg	R/W	Bit 7	Bit 6	Bit 5	Bit 4	Bit 3	Bit 2	Bit 1	Bit 0
CFR0	R/W	—	—	R64T	R25T	R16T	R15T	AFRST	ILOSS
Default State on RESET		—	—	1	1	1	1	1	1

Register	Bit	Symbol	Name/Description
CFR0	0	ILOSS	Insertion Loss Test Control. The insertion loss test mode is initiated by setting AFRST = 0 and ILOSS = 0, and then setting AFRST = 1. When enabled, the U-interface transmitter continuously transmits the sequence SN1. The U-interface receiver remains reset. The U-interface transceiver performs an internal reset when the ILOSS bit returns to its inactive state. 0—U-transmitter sends SN1 tone continuously. 1—No effect on device operation (default).
CFR0	1	AFRST	Adaptive Filter Reset. U transceiver reset. Assertion of this bit halts U-interface data transmission and clears adaptive filter coefficients. During AFRST, the U transmitter produces 0 V and has an output impedance of 135 Ω. If the microprocessor interface is being used, the AFRST bit should be used to place the device in quiet mode for U-interface maintenance procedures. Assertion of AFRST does not reset the microprocessor register bits or the U-interface timing recovery. 0—U transceiver reset. 1—No effect on device operation (default).
CFR0	3—2	R[16:15]T	Transmit Reserved Bits. Controls R _{1,6} and R _{1,5} in transmit U-interface data stream. 11—(Default.)
CFR0	4	R25T	Transmit Reserved Bit. Controls R _{2,5} in transmit U-interface data stream. 1—(Default.)
CFR0	5	R64T	Transmit Reserved Bit. Controls R _{6,4} in transmit U-interface data stream. 1—(Default.)

Microprocessor Interface Description (continued)

Registers (continued)

Table 10. Control Flow State Machine Status (Address 07h)

Reg	R/W	Bit 7	Bit 6	Bit 5	Bit 4	Bit 3	Bit 2	Bit 1	Bit 0
CFR1	R	—	AIB	FEBE	NEBE	UOA	OOF	XACT	ACTR

Register	Bit	Symbol	Name/Description
CFR1	0	ACTR	Receive Activation. Follows act bit in receive U-interface data stream. 0—Pending activation. 1—Ready to transmit.
CFR1	1	XACT	U Transceiver Active. 0—Transceiver not active. 1—Transceiver starting up or active.
CFR1	2	OOF	Out of Frame. 0—U-interface out of frame. 1—Normal.
CFR1	3	UOA	U-Interface Only Activation. Follows uoa bit in receive U-interface data stream. 0—U-interface only for activation. 1—U-interface and S/T-interface for activation.
CFR1	4	NEBE	Near-End Block Error. Follows nebe bit in receive U-interface data stream. 0—CRC error detected in previously received U frame. 1—No error.
CFR1	5	FEBE	Far-End Block Error. Follows febe bit in receive U-interface data stream. 0—Error detected at LT. 1—No error.
CFR1	6	AIB	Alarm Indication Bit. Follows aib in receive U-interface data stream. 0—Failure of intermediate 2B+D transparent element. 1—Transmission path established between LT and NT.

Table 11. Control Flow State Machine Status—Reserved Bits (Address 08h)

Reg	R/W	Bit 7	Bit 6	Bit 5	Bit 4	Bit 3	Bit 2	Bit 1	Bit 0
CFR2	R	—	R64R	R54R	R44R	R34R	R25R	R16R	R15R

Register	Bit	Symbol	Name/Description
CFR2	1—0	R[16:15]R	Receive Reserved Bits. Follows R _{1,5} and R _{1,6} in receive U-interface data stream.
CFR2	2	R25R	Receive Reserved Bits. Follows R _{2,5} in receive U-interface data stream.
CFR2	6—3	R[64:54:44:34]R	Receive Reserved Bits. Follows R _{3,4} ; R _{4,4} ; R _{5,4} ; and R _{6,4} in receive U-interface data stream.

Microprocessor Interface Description (continued)**Registers** (continued)**Table 12. EOC State Machine Control—Address (Address 09h)**

This register has no effect on device operation if AUTOEOC = 1 (register GR0, bit 4).

Reg	R/W	Bit 7	Bit 6	Bit 5	Bit 4	Bit 3	Bit 2	Bit 1	Bit 0
ECR0	R/W	CCRC	U2BDLT	UB2LP	UB1LP	DMT	A1T	A2T	A3T
Default State on RESET		1	1	1	1	1	0	0	0

Register	Bit	Symbol	Name/Description
ECR0	0—2	A[3:1]T	Transmit EOC Address. 000—NT address (default). 111—Broadcast address.
ECR0	3	DMT	Transmit EOC Data or Message Indicator. 0—Data. 1—Message (default).
ECR0	4	UB1LP	U-Interface Loopback of B1 Channel Control. Control for U-interface transparent B1 loopback. UB1LP and UB2LP may be enabled concurrently. 0—B1 channel loopback from U-interface receive to U-interface transmit upstream of data flow matrix. 1—No loopback (default).
ECR0	5	UB2LP	U-Interface Loopback of B2 Channel Control. Control for U-interface transparent B2 loopback. UB1LP and UB2LP may be enabled concurrently. 0—B2 channel loopback from U-interface receive to U-interface transmit upstream of data flow matrix. 1—No loopback (default).
ECR0	6	U2BDLT	Transparent 2B+D Loopback Control. When activated, this bit causes a transparent 2B+D loopback. 0—Transparent 2B+D loopback: The microprocessor must clear the data flow matrix (UXB10 = UXB11 = UXB20 = UXB21 = UXD = 1) for proper operation of the loopback. 1—No loopback (default).
ECR0	7	CCRC	Corrupt Cyclic Redundancy Check. Used to corrupt the CRC information transmitted at the U-interface. 0—Corrupt CRC generation. 1—Generate correct CRC (default).

Microprocessor Interface Description (continued)

Registers (continued)

Table 13. EOC State Machine Control—Information (Address 0Ah)

This register has no effect on device operation if AUTOEOC = 1 (register GR0, bit 4).

Reg	R/W	Bit 7	Bit 6	Bit 5	Bit 4	Bit 3	Bit 2	Bit 1	Bit 0
ECR1	R/W	I1T	I2T	I3T	I4T	I5T	I6T	I7T	I8T
Default State on RESET		1	1	1	1	1	1	1	1

Register	Bit	Symbol	Name/Description
ECR1	0—7	I[8:1]T	Transmit EOC Information. These bits are transmitted as the EOC channel message when in manual EOC mode. See EOC State Machine Description section for a list of possible EOC messages.

Table 14. EOC State Machine Status—Address (Address 0Bh)

This register contains the currently received EOC address and data/message indicator bits independent of the state of AUTOEOC (register GR0, bit 4).

Reg	R/W	Bit 7	Bit 6	Bit 5	Bit 4	Bit 3	Bit 2	Bit 1	Bit 0
ECR2	R	—	—	—	—	DMR	A1R	A2R	A3R

Register	Bit	Symbol	Name/Description
ECR2	0—2	A[3:1]R	Receive EOC Address. These bits store the received EOC address. 000 = NT address. 001—110 = Intermediate element addresses. 111 = Broadcast address.
ECR2	3	DMR	Receive EOC Data or Message Indicator. 0—Data. 1—Message.

Table 15. EOC State Machine Status—Information (Address 0Ch)

This register contains the currently received EOC information bits independent of the state of AUTOEOC (register GR0, bit 4).

Reg	R/W	Bit 7	Bit 6	Bit 5	Bit 4	Bit 3	Bit 2	Bit 1	Bit 0
ECR3	R	I1R	I2R	I3R	I4R	I5R	I6R	I7R	I8R

Register	Bit	Symbol	Name/Description
ECR3	0—7	I[8:1]R	Receive EOC Information. Receive EOC channel message or data.

Microprocessor Interface Description (continued)**Registers** (continued)**Table 16. U-Interface Interrupt Register (Address 0Dh)**

These bits are cleared during $\overline{\text{RESET}}$.

Reg	R/W	Bit 7	Bit 6	Bit 5	Bit 4	Bit 3	Bit 2	Bit 1	Bit 0
UIR0	R	—	—	TSFINT	RSFINT	OUSC	BERR	ACTSC	EOCSC

Register	Bit	Symbol	Name/Description
UIR0	0	EOCSC	EOC State Change on U-Interface. Activates (set to 1) when the received EOC message changes state. Bit is cleared on read. See EOC State Machine Description section for details. 0—No change in EOC state. 1—EOC state change.
UIR0	1	ACTSC	Activation/Deactivation State Change on U-Interface. Activates (set to 1) during changes in the status bits monitoring U-interface activation and deactivation (ACTR and XACT, register CFR1, bits 0 and 1). Bit cleared on read. 0—No activation/deactivation activity. 1—Change in state of activation/deactivation bits.
UIR0	2	BERR	Block Error on U-Interface. Activates (set to 1) when received signal contains either a near-end (NEBE = 0) or a far-end (FEBE = 0) block error. Bit cleared on read. 0—No block errors. 1—Block error.
UIR0	3	OUSC	Other U-Interface State Change. Activates (set to 1) when any of the following bits change state: OOF, UOA, AIB, and Rx, y (all reserved U-interface status bits). Bit cleared on read. 0—No state change. 1—State change.
UIR0	4	RSFINT	Receive Superframe Interrupt. Activates (set to 1) when the receive superframe boundary occurs. Bit cleared on read. 0 to 1—First 2B+D data of the receive U superframe.
UIR0	5	TSFINT	Transmit Superframe Interrupt. Activates (set to 1) when the transmit superframe boundary occurs. Bit cleared on read. 0 to 1—First 2B+D data of the transmit U superframe.

Microprocessor Interface Description (continued)

Registers (continued)

Table 17. U-Interface Interrupt Mask Register (Address 0Eh)

Reg	R/W	Bit 7	Bit 6	Bit 5	Bit 4	Bit 3	Bit 2	Bit 1	Bit 0
UIR1	R/W	—	—	TSFINTM	RSFINTM	OUSCM	BERRM	ACTSCM	EOCSCM
Default State on $\overline{\text{RESET}}$		—	—	1	1	1	1	1	1

Register	Bit	Symbol	Name/Description
UIR1	0	EOCSCM	EOC State Change on U-Interface Mask. 0—EOCSC interrupt enabled. 1—EOCSC interrupt disabled (default).
UIR1	1	ACTSCM	Activation/Deactivation State Change on U-Interface Mask. 0—ACTSC interrupt enabled. 1—ATCSC interrupt disabled (default).
UIR1	2	BERRM	Block Error on U-Interface Mask. 0—BERR interrupt enabled. 1—BERR interrupt disabled (default).
UIR1	3	OUSCM	Other U-Interface State Change Mask. 0—OUSC interrupt enabled. 1—OUSC interrupt disabled (default).
UIR1	4	RSFINTM	Receive Superframe Interrupt Mask. 0—RSFINT interrupt enabled. 1—RSFINT interrupt disabled (default).
UIR1	5	TSFINTM	Transmit Superframe Interrupt Mask. 0—TSFINT interrupt enabled. 1—TSFINT interrupt disabled (default).

Table 18. Maintenance Interrupt Register (Address 0Fh)

These bits are cleared during $\overline{\text{RESET}}$.

Reg	R/W	Bit 7	Bit 6	Bit 5	Bit 4	Bit 3	Bit 2	Bit 1	Bit 0
MIR0	R	—	—	—	—	—	EMINT	ILINT	QMINT

Register	Bit	Symbol	Name/Description
MIR0	0	QMINT	Quiet Mode Interrupt. Activates (set to 1) when the ANSI maintenance state machine detects a request on the OPTOIN pin for the device to enter the quiet mode. Bit is cleared on read. 0—No quiet mode request. 1—Quiet mode requested.
MIR0	1	ILINT	Insertion Loss Interrupt. Activates (set to 1) when the ANSI maintenance state machine has detected a request on the OPTOIN pin for the device to transmit the SN1 tone on the U-interface. Bit is cleared on read. 0—No SN1 tone request. 1—SN1 tone requested.
MIR0	2	EMINT	Exit Maintenance Mode Interrupt. Activates (set to 1) when the ANSI maintenance state machine detects a request on the OPTOIN pin for the device to exit the current maintenance mode. Bit is cleared on read. 0—No exit request. 1—Exit requested.

Microprocessor Interface Description (continued)**Registers** (continued)**Table 19. Maintenance Interrupt Mask Register (Address 10h)**

Reg	R/W	Bit 7	Bit 6	Bit 5	Bit 4	Bit 3	Bit 2	Bit 1	Bit 0
MIR1	R/W	—	—	—	—	—	EMINTM	ILINTM	QMINTM
Default State on $\overline{\text{RESET}}$		—	—	—	—	—	1	1	1

Register	Bit	Symbol	Name/Description
MIR1	0	QMINTM	Quiet Mode Interrupt Mask. 0—QMINT interrupt enabled. 1—QMINT interrupt disabled (default).
MIR1	1	ILINTM	Insertion Loss Interrupt Mask. 0—ILINT interrupt enabled. 1—ILINT interrupt disabled (default).
MIR1	2	EMINTM	Exit Maintenance Mode Interrupt Mask. 0—EMINT interrupt enabled. 1—EMINT interrupt disabled (default).

Table 20. Global Interrupt Register (Address 11h)

These bits are cleared during $\overline{\text{RESET}}$.

Reg	R/W	Bit 7	Bit 6	Bit 5	Bit 4	Bit 3	Bit 2	Bit 1	Bit 0
GIR0	R	—	—	—	—	—	MINT	—	UINT

Register	Bit	Symbol	Name/Description
GIR0	0	UINT	U Transceiver Interrupt. Activates (set to 1) when any of the unmasked U transceiver interrupt bits (register UIR0) activate. 0—No U transceiver interrupts. 1—U transceiver interrupt active.
GIR0	2	MINT	Maintenance Interrupt. Activates (set to 1) when any of the unmasked maintenance interrupt bits (register MIR0) activate. 0—No maintenance interrupts. 1—Maintenance interrupt active.

Microprocessor Interface Description (continued)

Timing

The microprocessor interface is compatible with any microprocessor that supports a synchronous serial microprocessor port such as the following:

- NEC¹ 75402
- Motorola² MC68HC05 and MC68302 SCP port
- Intel³ 80C51

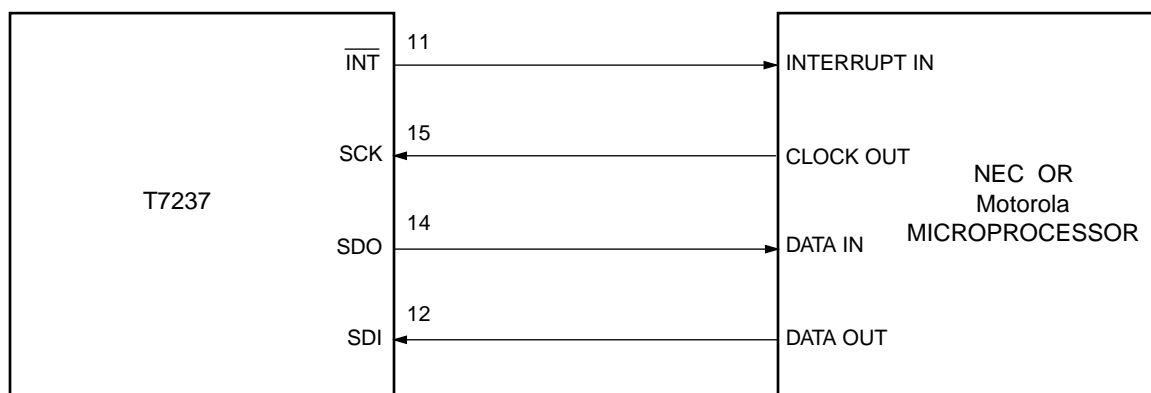

5-2300 (C)

Figure 9. NEC and Motorola Microprocessor Port Connections

The synchronous interface consists of the microprocessor input clock (SCK), serial data input (SDI), and serial data output (SDO). A microprocessor interrupt lead ($\overline{\text{INT}}$) is also included. These connections are shown in Figure 9 for applications using either NEC or Motorola microprocessors. Figure 10 shows the connections for applications using a multiplexed data out/in scheme such as the Intel 80C51 or equivalent.

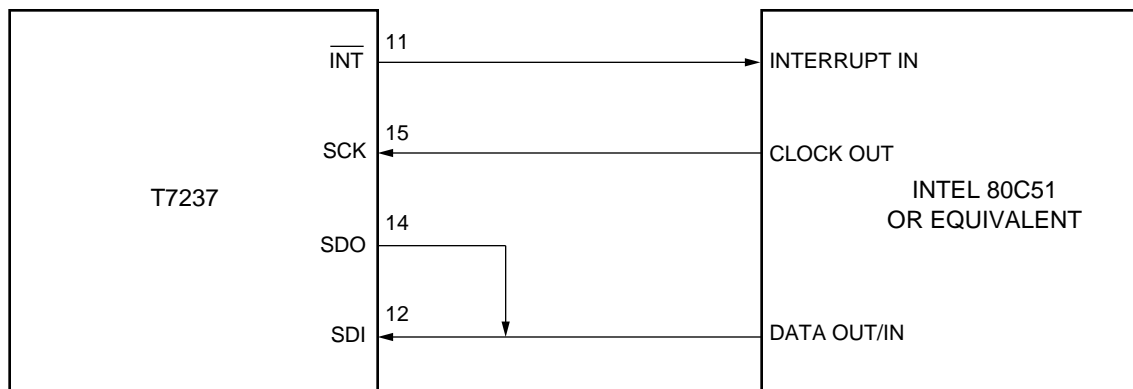

5-2301 (C)

Figure 10. Intel Microprocessor Port Connections

1. NEC is a registered trademark of NEC Electronics, Inc.
2. Motorola is a registered trademark of Motorola, Inc.
3. Intel is a registered trademark of Intel Corporation.

Microprocessor Interface Description (continued)

Timing (continued)

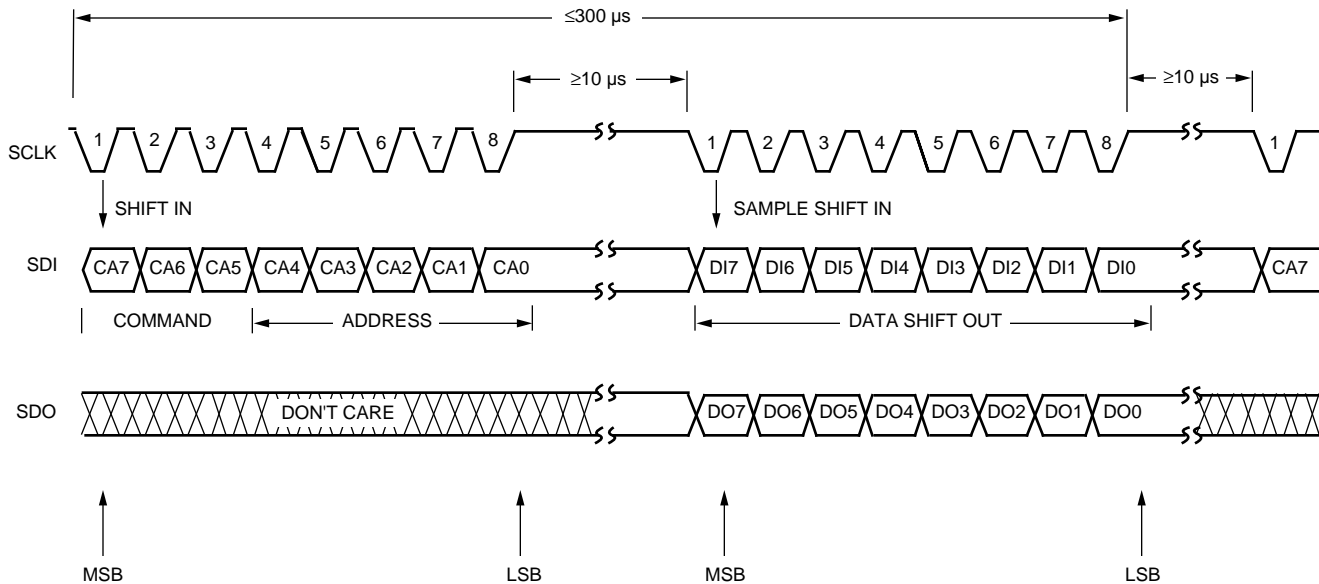

Note: If SCLK is initially low, it must be held high for $>300 \mu\text{s}$ before its first falling edge. From that point forward, the above timing applies.

5-2302 (C)

Figure 11. Synchronous Microprocessor Port Interface Format

Figure 11 shows the basic transfer format. All data transfers are initiated by the microprocessor, although the interrupt may indicate to the microprocessor that a register read or write is required. The microprocessor should normally hold the SCK pin high during inactive periods and only make transitions during register transfers. The maximum clock rate of SCK is 960 kHz. Data changes on the falling edge of SCK and is latched on the rising edge of SCK.

Each complete serial transfer consists of 2 bytes (8 bits/byte). The first byte of data received over the SDI pin from the microprocessor consists of command/address information that includes a 5-bit register address in the least significant bit positions (CA4—CA0) and a 3-bit command field in the most significant bit positions (CA7—CA5). The byte is defined as follows:

- Bits CA7—CA5: 001 = read, 010 = write, all other bit patterns will be ignored.
- Bits CA4—CA0: 00000 = register address 0, 00001 = register address 1, etc.

The second byte of data received over the SDI pin consists of write data for CA7—CA5 = 010 (write) or don't care information for CA7—CA5 = 001 (read).

The data transmitted over the SDO pin to the microprocessor during the first byte transfer is a don't care for both read and write operations. The second byte transmitted over the SDO pin consists of read data for CA7—CA5 = 001 (read) or don't care information for CA7—CA5 = 010 (write).

In order for the T7237 to recognize the identity (command/address or data) of the byte being received, it is required that the time allowed to transfer an entire instruction (time from the receipt of the first bit of the command/address byte to the last bit of the data byte) be limited to less than $300 \mu\text{s}$. This limits the minimum SCK rate to 60 kHz. If the complete instruction is received in less than $300 \mu\text{s}$, the T7237 accepts the instruction immediately and is ready to receive the next instruction after a $10 \mu\text{s}$ delay. If the complete instruction is not received within $300 \mu\text{s}$, the bits received in the previous $300 \mu\text{s}$ are discarded and the interface is prepared to receive a new instruction after a $10 \mu\text{s}$ delay. In addition, a minimum $10 \mu\text{s}$ delay must exist between the command/address and data bytes.

Microprocessor Interface Description

(continued)

Timing (continued)

For microprocessors using a multiplexed data out/in pin to drive SDI and SDO (as shown in Figure 8), a read instruction to T7237 will require that the microprocessor data in/out pin be an output during the command/address byte written to T7237, and then switch to an input to read the data byte T7237 presents on the SDO pin in response to the read command. In this case, the microprocessor data in/out pin must 3-state within 1.46 μ s of the final SCK rising edge of the command/address byte to ensure that there is no contention between the microprocessor data out pin and the T7237 SDO pin.

Time-Division Multiplexed (TDM) Bus Description

The TDM bus facilitates B1-, B2-, and D-channel communication between the T7237 and peripheral devices such as codecs, HDLC processors, time-slot interchangers, synchronous data interfaces, etc. The following list is a subset of the devices that can connect directly to the T7237 TDM bus:

- Lucent T7570 and T7513 Codecs
- Lucent T7270 Time-Slot Interchanger
- Lucent T7121 HDLC Formatter
- National Semiconductor*3070 Codec

The bus can be used to extract data from U-interface receivers, process the data externally, and source data to the appropriate transmitters with the processed data. The bus can also be used to simply monitor 2B+D channel data flow within the T7237 without modifying it. The bus also supports board-level testing procedures using in-circuit techniques (see the Board-Level Testing section for more details). Upon powerup, the TDM bus is not selected. Pins 4, 7, 8, and 9 form the TDM bus when TDMEN is set to 0 (register GR2, bit 5).

The TDM bus consists of a 2.048 MHz output clock (TDMCLK), data in (TDMDI), data out (TDMDO), and a programmable frame strobe lead (FS). The frame

strobe timing can be configured via the microprocessor register bits FSC and FSP in register TDR0. Data appearing and expected on the bus is controlled via the B1-, B2-, and D-channel data flow register bits (registers DFR0 and DFR1). The TDMCLK and FS outputs only become active if one or more of the TDM time slots is enabled (see register DFR1, Table 7).

Clock and Data Format

The clock and data signals for the TDM bus are TDMCLK, TDMDO, and TDMDI (see Figure 12). TDMCLK is a 2.048 MHz output clock. TDMDO is the 2B+D data output for data derived from the U-interface receiver. The TDMDO output driver is only active during a time slot when it is driving data off-chip; otherwise, the output driver is 3-stated (this includes the 6-bit interval in the D-channel octet). TDMDI is the 2B+D data input for data used to drive the U-interface transmitter.

On both the TDMDO and TDMDI leads, three 8-bit time slots are reserved for the B1-, B2-, and D-channels associated with the U-interfaces. The relative locations of the time slots are fixed; however, the frame strobe is programmable. The total number of time slots available within each frame strobe period is 32. During unused time slots, data on TDMDI is ignored and TDMDO is 3-stated.

Frame Strobe

The FS frame strobe is a programmable output associated with the TDM bus. FS can be configured to serve as an envelope strobe for any of the three reserved time slots available on the bus: U-interface B1, B2, and D. FS can also be programmed as a 2B+D envelope for the U-interface time slots. FS can be used to directly drive a codec for voice applications or can be used to control other external devices such as HDLC controllers.

Figure 12 shows the relationship between the TDMCLK, TDMDO, and TDMDI time slots, and the FS strobe for some example programmable settings. Detailed descriptions of TDM bus interface timing are given in the Timing Characteristics section of this document.

* National Semiconductor is a registered trademark of National Semiconductor Corporation.

Time-Division Multiplexed (TDM) Bus Description (continued)

Frame Strobe (continued)

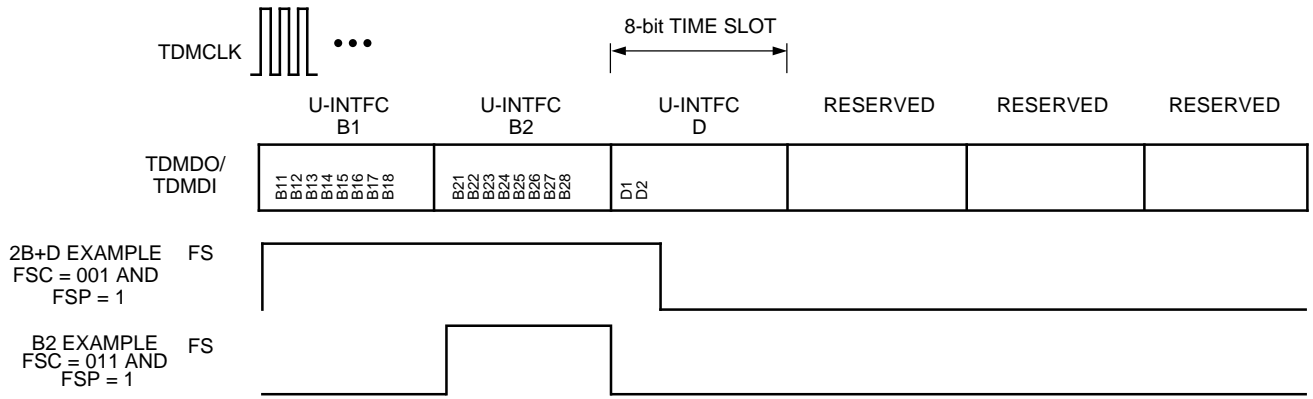

5-2303a (C)

Figure 12. TDM Bus Time-Slot Format

Data Flow Matrix Description

B1-, B2-, D-Channel Routing

The T7237 supports extremely flexible B1-, B2-, and D-channel routing among major circuit blocks in order to accommodate various applications. Channel routing is controlled via the data flow control registers, DFR0 and DFR1. Figure 13 shows a block diagram of the device and the channel paths to and from the U transceiver and TDM bus interface. Channel flow is determined by specifying the source of channel data at the two points shown in the figure: (1) U transceiver transmit input and (2) TDM bus transmit input. Channel flow at the TDM bus receive input is determined, by default, from the settings at the other two points. A switch matrix within the data flow matrix block routes channels to and from the specified points.

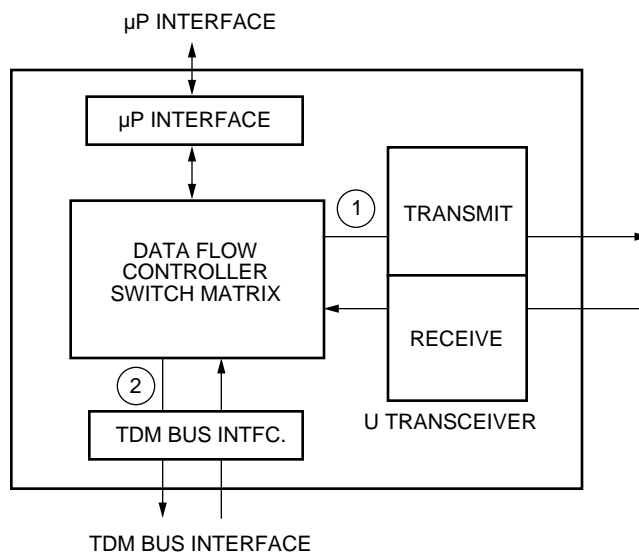

5-2304.b (C)

Figure 13. B1-, B2-, D-Channel Routing

Data Flow Matrix Description (continued)

B1-, B2-, D-Channel Routing (continued)

As an example, below are the register settings required to configure the device as a U-interface terminal adapter, with the B1, B2, and D channels in the U-interface made available on the TDM bus for monitoring:

- TDMEN = 0 (enables TDM bus).
- UXB1 = 01, UXB2 = 01, UXD = 0 (routes TDM bus data to U-interface transmitter).
- TDMB1U = TDMB2U = 0 (brings out B1 and B2 channels from U-interface to TDM bus).
- TDMDU = 0 (D channel from U-interface brought out on TDM bus).

Loopbacks

The figure below shows the Layer-1 loopbacks that are defined in ITU-T I.430, Appendix I and ANSI Specification T1.605, Appendix G. A complete discussion of these loopbacks is presented in ITU-T I.430, Appendix I.

If a U-interface transparent B1 or B2 loopback is requested via an EOC message, the proper channel is looped upstream of the data flow matrix. All other device functions are unaffected.

If a U-interface transparent 2B+D loopback is requested via an EOC message (loop 2 in Figure 14), the 2B+D data will be looped as close to the T-interface as possible.

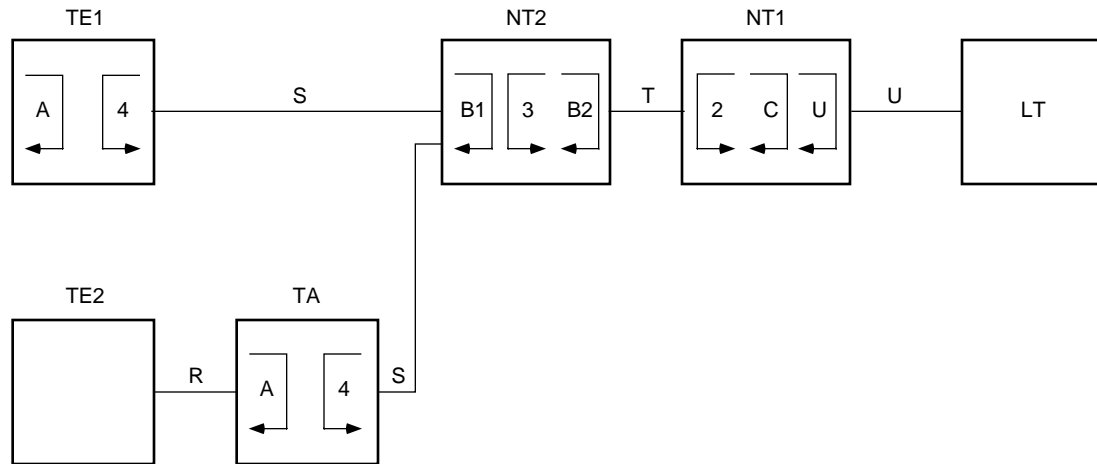

TE1 = ISDN terminal
TE2 = Non-ISDN terminal
TA = Terminal adapter
NT2 = Network termination 2
NT1 = Network termination 1
LT = Line termination

R = R reference point
S = S reference point
T = T reference point
U = U reference point

Loopback	Channel(s) Looped
2	2B+D channels
3	2B+D channels
4	B1, B2
C	B1, B2
B1 or B2	2B+D, B1, B2
A	2B+D, B1, B2

5-2482 (C)

Figure 14. Location of the Loopback Configurations (Reference ITU-T I.430 Appendix I)

Modes of Operation

The T7237 transceiver operates under microprocessor control through the serial interface. The T7237 automatically handles U-interface activation, control, and maintenance according to the ANSI T1.601 standard.

In addition, the T7237 allows manual EOC and U overhead bit manipulation. The microprocessor port is accessed via the SDI, SDO, and SCK pins (see Microprocessor Interface Description and Timing Characteristics sections for details). Table 21 shows the transceiver control pins that are most relevant to the microprocessor.

Table 21. Microprocessor Mode

Pin	Symbol	Comment
2	OPTOIN	Controlled by microprocessor bit AUTOCTL (register GR0).
4	FS	Controlled by microprocessor bit TDMEN (register GR2).
6	ILOSS	Controlled by microprocessor bit AUTOCTL (register GR0).
7	TDMDI	Controlled by microprocessor bit TDMEN (register GR2).
8	TDMDO	Controlled by microprocessor bit TDMEN (register GR2).
9	TDMCLK	Controlled by microprocessor bit TDMEN (register GR2).
11	$\overline{\text{INT}}$	Interrupt output for the microprocessor interface.
12	SDI	Serial data input for the microprocessor interface.
14	SDO	Serial data output for the microprocessor interface.
15	SCK	Master clock input for the microprocessor interface.

STLED Description

The STLED pin is used to drive an LED and provides a visual indication of the current state of the T7237. The STLED control is typically configured to illuminate the LED when STLED is LOW. This convention will be assumed throughout this section.

Table 22 describes the three states of STLED, the list of system conditions that produce the state, and the corresponding ANSI states, as defined in ANSI T1.601-1992 (Tables C1 and C4) and ETSI ETR 080-1992 (Tables A3 and I2).

Note: The ETSI state names begin with the letters NT instead of H. Also, the ETSI state tables do not include a state NT11 because it is considered identical to state NT6. Table A3 of the ETSI standard contains the additional states NT6A, NT7A, and NT8A to describe states related to the EOC loopback 2 (2B+D loopback). The most likely ANSI state for each STLED state is shown in bold typeface in Table 22.

The flow chart in Figure 15 illustrates the priority of the logic signals which control the STLED pin. In the decision diamonds, those names in all capital letters denote T7237 register bit names. The RESET, AUTOCTL, and AUTOEOC are R/W bits controlled by the user via the microprocessor interface. The XACT, OOF, and aib bits are read-only bits determined by the internal logic based on system events and can be monitored by the user via the microprocessor interface. Other names in the decision diamonds (quiet mode, ILOSS mode, Loop2) represent system conditions that cannot be directly monitored or controlled by the microprocessor interface.

Table 22. STLED States

STLED State	List of System Conditions that Can Cause STLED State	Corresponding ANSI States
High (LED off)	RESET (pin 43) = 0 AUTOCTL = 0 (register GR0, bit 3), or AUTOEOC = 0 (register GR0, bit 4), or STOA = 0 (register GR2, bit 7)	NA
	U not active	H0, H1 , H10, H12
8 Hz Flashing	RESET = 0 (register GR0, bit 0) Quiet mode active, or ILOSS mode active	NA
	U activation attempt in progress	H2, H3, H4
	AIB = 0 (register CFR1, bit 6)	H7, H8
	EOC-initiated 2B+D loopback active	NT6A*, NT7A*, NT8A*
1 Hz Flashing	U active, S/T not fully active	H6, H6(a), H7 , H11, H8(a) [†] , H8(b), H8(c)

* These are ETSI DTR/TM-3002 states not yet defined in ANSI T1.601, although they are defined in revised ANSI tables which are currently on the living list (i.e., not yet an official part of the standards document).

† State H8(a) is most likely when U-interface bit uoa = 0.

STLED Description (continued)

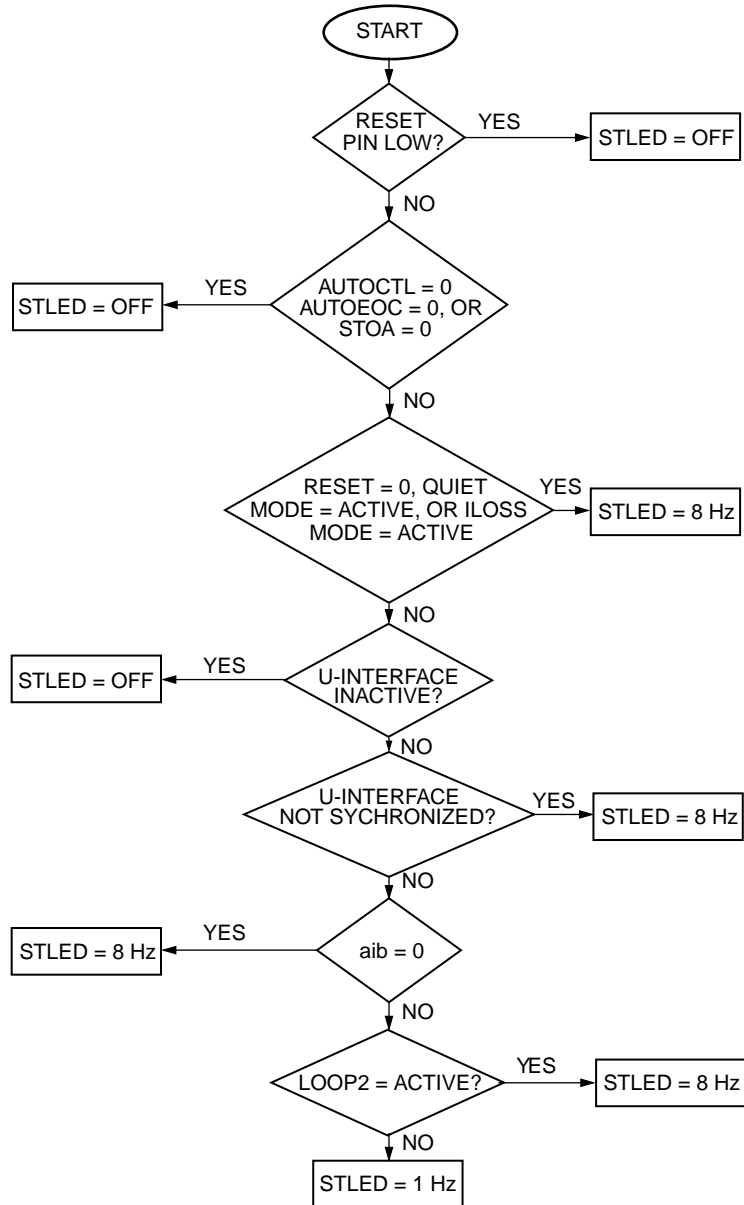

5-3599.c (F)

Figure 15. STLED Control Flow Diagram

EOC State Machine Description

The following list shows the eight EOC states defined in ANSI T1.601 and ETSI ETR 080. The bit pattern below represents the state of U-interface overhead bits EOC_{i1}—EOC_{i8}, respectively (see Table 2).

- 01010000—Operate 2B+D loopback.
- 01010001—Operate B1 channel loopback.
- 01010010—Operate B2 channel loopback.
- 01010011—Request corrupt CRC.
- 01010100—Notify of corrupted CRC.
- 11111111—Return to normal (default).
- 00000000—Hold state.
- 10101010—Unable to comply.

Normally, the T7237 automatically handles the EOC channel processing per the ANSI and ETSI standards. There may be some applications where manual control of the EOC channel is desired (e.g., equipment that is meant to test the EOC processing of upstream elements by writing incorrect or delayed EOC data). This can be accomplished by setting AUTOEOC = 0 (register GR0, bit 4). The EOC state change interrupt is enabled by setting EOCSCM = 0 (register UIR1, bit 0). This allows state changes in the received EOC messages (registers ECR2 and ECR3) to be indicated to the microprocessor by the assertion of UINT = 1 (register GIR0, bit 0) and EOCSC = 1 (register UIR0, bit 0). The microprocessor reads registers ECR2 and ECR3 to determine which received EOC bits changed. Then, it updates the transmit EOC values by writing registers ECR0 and ECR1 and takes appropriate action (e.g., enable a requested loopback). The total manual EOC procedure consists of the following steps:

1. Microprocessor detects $\overline{\text{INT}}$ pin going low.
2. Microprocessor reads GIR0 and determines that the UINT bit is set.
3. Microprocessor reads UIR0 and determines that the EOCSC bit is set.
4. Microprocessor reads ECR2.
5. Microprocessor reads ECR3.
6. Microprocessor interrupts newly received EOC message and determines the appropriate response.
7. Microprocessor writes ECR0 based on results of step 6.
8. Microprocessor writes ECR1 based on results of step 6.

The maximum time allowed from the assertion of the $\overline{\text{INT}}$ pin (step 1) until the completion of the last write cycle to the EOC registers (step 8) is 1.5 ms.

ANSI Maintenance Control Description

The ANSI maintenance controller of the T7237 can operate in fully automatic or in fully manual mode. Automatic mode can be used in applications where autonomous control of the metallic loop termination (MLT) maintenance is desired. The MLT capability implemented with the Lucent LH1465AB and an opto-coupler provides a dc signature, sealing current sink, and maintenance pulse-level translation for the testing facilities. Maintenance pulses from the U-interface MLT circuit are received by the OPTOIN pin and digitally filtered for 20 ms. The device decodes these pulses according to ANSI maintenance state machine requirements and responds to each request automatically.

For example, the T7237 will place itself in the quiet mode if six pulses are received from the MLT circuitry. Microprocessor interrupts in register MIR0 are available for tracking maintenance events if desired.

Manual mode can be used in applications where an external maintenance decoder is used to drive the $\overline{\text{RESET}}$ and $\overline{\text{ILOSS}}$ pins of the T7237. In this mode, the $\overline{\text{RESET}}$ pin places the device in quiet mode and the $\overline{\text{ILOSS}}$ pin controls SN1 tone transmission. Maintenance events are not available in register MIR0 when in manual mode.

Board-Level Testing

The T7237 provides several board-level testability features. For example, the $\overline{\text{HIGHZ}}$ pin 3-states all digital outputs for bed-of-nails testing. Also, various loopbacks can be used to verify device functionality.

External Stimulus/Response Testing

External data transparency of the B1, B2, and D channels can be verified by the combined use of the TDM bus and microprocessor port. Data flow within the device can be configured by the external controller through the microprocessor port, and B1-, B2-, and D-channel data can be transmitted into and received from the device via the TDM bus. Using this method, arbitrary data patterns can be used to stimulate the device and combinations of loopbacks can be exercised to help detect and isolate faults. Figure 16 illustrates this general-purpose testing configuration.

TDMDI data can be routed through the device and back to TDMDO at the U-interface. For looping at U-interface, the procedure is as follows:

- Disconnect the U-interface from the telephone network.
- Set TDMEN = 0 in register GR2, bit 5.
- Set register DFR0 to 11110101.
- Set register DFR1 to 00011110.
- Set register TDR0 as required for the desired frame strobe location and polarity.

Now, write LPBK in register GR1 to a 0. This causes the chip to enter the U-interface loopback mode. Any data entering the TDM highway on TDMDI will be looped back (with some delay) on TDMDO.

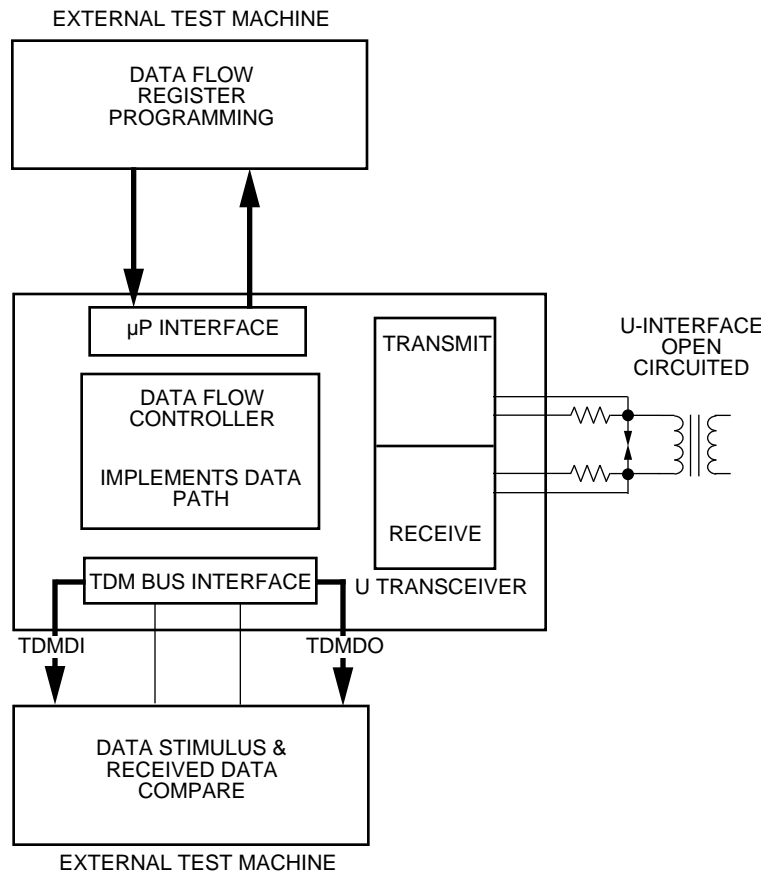

5-2305.a (C)

Figure 16. External Stimulus/Response Configuration

Application Briefs

T7237 Reference Circuit

A reference circuit illustrating the T7237 in a standard application, including complete ANSI maintenance support, is shown in Figure 17. A bill of materials for the schematic is shown in Table 23. Note that specific applications may vary depending on individual requirements.

U-Interface

The U-Interface attaches to the board at RJ-45 connector J1 (see Figure 17). F1 and VR2 provide overcurrent and overvoltage protection, respectively. These two devices in combination with transformer T1 provide protection levels required by FCC Part 68 and UL* 1459. For an in-depth discussion of protection issues, the following application notes are helpful.

1. "Overvoltage Protection of Solid-State Subscriber Loop Circuits," Lucent Analog Line Card Components Data Book (CA94-007ALC) 800-372-2447.
2. Protection of Telecommunications Customer Premises Equipment, Raychem† Corporation, 415-361-6900.

C16 is a 1.0 μ F dc blocking capacitor that is required per ANSI T1.601, Section 7.5.2.3. The 250 V rating of C16 is governed by the maximum breakdown voltage of VR2, since the capacitor must not break down before VR2. The resistance of R13 (21 Ω) and F1 (12 Ω) provides a total line-side resistance of 33 Ω , which is required when using the Lucent 2754H2 transformer (see the note at the end of Table 23 for information on R13 values when using other transformers).

On the device side of the U-interface transformer, VR1 provides secondary overvoltage protection of 6.8 V. Optional capacitors C13 and C14 provide common-mode noise suppression for applications that are required to operate in the presence of high common-mode noise. R6 and R7 provide the necessary external hybrid resistors.

* UL is a registered trademark of Underwriters Laboratories, Inc.

† Raychem is a registered trademark of Raychem Corporation.

MLT Circuit

The metallic loop termination (MLT) circuit (U3 and related components in Figure 17) provides a dc termination for the loop per ANSI T1.601, Section 7.5. R14 and R15 are power resistors used to sink current during overvoltage fault conditions. The optoisolator (U2) provides signal isolation and voltage translation of the signaling pulses used for NT maintenance modes, per T1.601, Section 6.5. The T7237 interprets these pulses via an internal ANSI maintenance state machine, and responds accordingly. For applications outside North America, the MLT circuit is not required.

Status LED

D1 in Figure 17 is an LED that is controlled by the STLED pin of the T7237 and indicates the status of the device (activating, out-of-sync, etc.). Table 22 and Figure 15 of this data sheet details the possible states of the STLED pin and the meaning of each state.

Power Status Leads

ANSI T1.601 Section 8.2.4 defines U-interface NT power status bits PS1 and PS2. These bits are transmitted across the U-Interface via the U maintenance channel. On the T7237, these bits are controlled by pins 8 and 9 (PS2E and PS1E). When the TDM highway is used (TA modes), the PS1/PS2 bits are controlled by internal registers that are written by an external microprocessor. In general, power status monitoring circuitry is dependent on various system parameters and requirements, and must be designed based on the specific application's requirements. For this reason, there is no power status monitoring circuitry shown in this design. Instead, pull-ups R1 and R2 in Figure 17 are provided to force a default indication of primary and secondary power good status.

Application Briefs (continued)

T7237 Reference Circuit (continued)

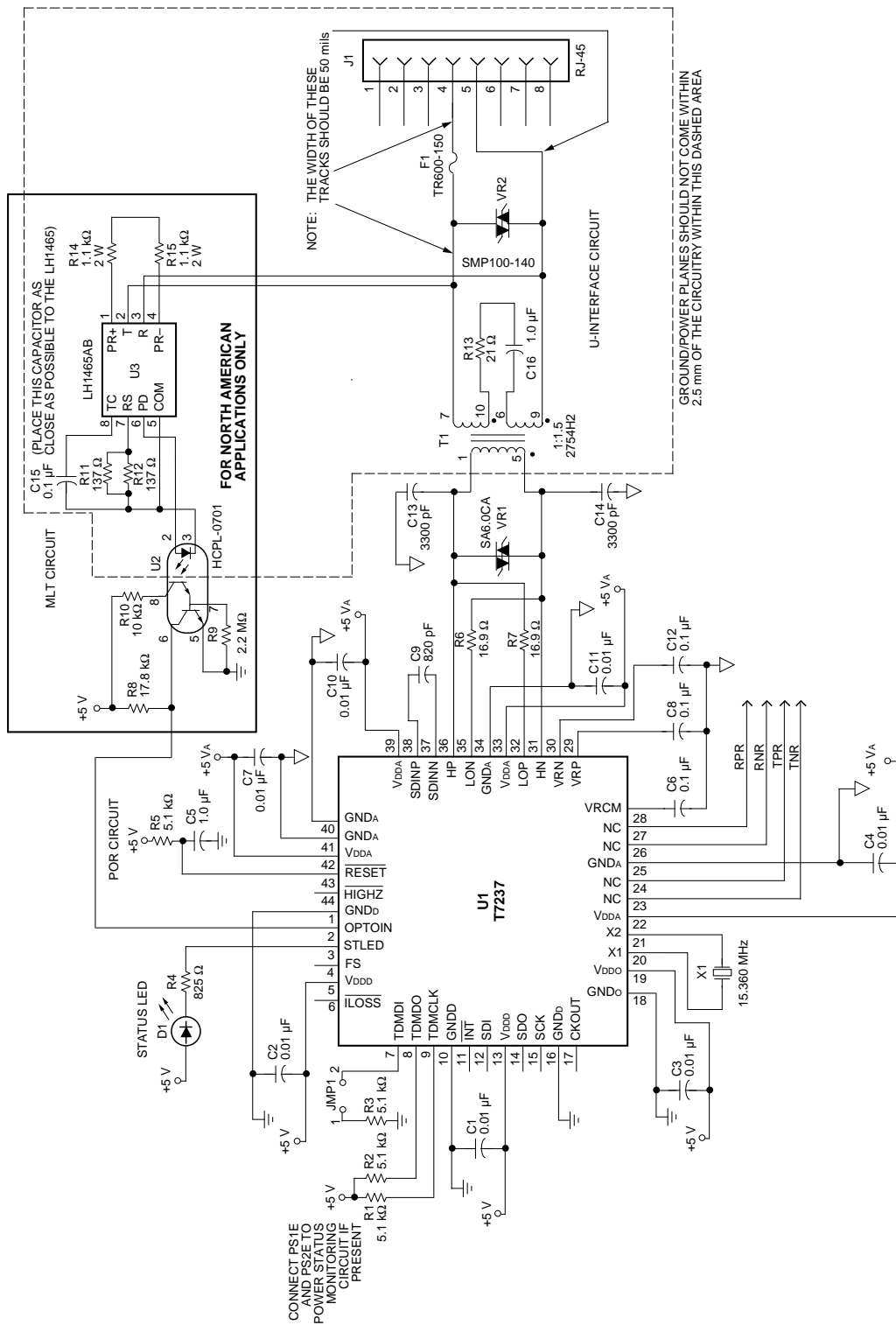

Figure 17. T7237 Reference Circuit

5-4048.i (C)

Application Briefs (continued)

T7237 Reference Circuit (continued)

Table 23. T7237 Reference Schematic Parts List

Reference Designator	Description	Source	Part #
C[1—4, 7, 10, 11]	Ceramic Chip Capacitor, 0.01 μ F, 10%, 50 V, X7R	Kemet ¹	C1206C103K5RAC
C5	Tantalum Chip Capacitor, 1.0 μ F, 10%, 16 V	Kemet	T491A105K016AS
C[6, 8, 12, 17]	Ceramic Chip Capacitor, 0.1 μ F, 10%, 50 V, X7R	Kemet	C1206C104K5RAC
C9	Ceramic Chip Capacitor, 820 pF, 5%, 50 V, NPO	Kemet	C0805C821J5GAC
C[13, 14]	Ceramic Chip Capacitor, 3300 pF, 10%, 50 V, X7R	Kemet	C1206C332F5RAC
C15	Polyester Capacitor, 0.1 μ F, 63 V, 10% Note: Insulation resistance of this part must be >2 G Ω .	Philips ²	2222 370 12104
C16	Capacitor, 1.0 μ F, 250 V, 10% Alternate: Philips 2222 373 41105	Vitramon ³ , via TMI (rep) (215) 830-8500	VJ9253Y105KXPM
D1	Green Surface-mount LED	Hewlett Packard ⁴	HSMG-C650
F1	Overcurrent Protector (Polyswitch ⁵) Alternate: Bel Fuse ⁶ MJS 1.00A, (201) 432-0463 See Note at the end of this table.	Raychem (415) 361-6900	TR600-150
J1	RJ-45 8-pin Modular Jack (standard height)	Molex ⁷	15-43-8588
JMP1	Two-position Header with Shorting Jumper	Multiple	—
R[1—3, 5]	SMC Resistor, 5.1 k Ω , 1/8 W, 5%	Dale ⁸	CRCW1206512J
R4	SMC Resistor, 825 k Ω , 1/8 W, 1%	Dale	CRCW12068250F
R[6, 7]	SMC Resistor, 16.9 k Ω , 1/8 W, 1%	Dale	CRCW120616R9F
R8	SMC Resistor, 17.8 k Ω , 1/8 W, 1%	Dale	CRCW12061783F
R9	SMC Resistor, 2.2 M Ω , 1/8 W, 5%	Dale	CRCW1206225J
R[10, 18, 19]	SMC Resistor, 10 k Ω , 1/8 W, 5%	Dale	CRCW1206103J
[R11, 12]	SMC Resistor, 137 Ω , 1/8 W, 1%	Dale	CRCW12061370F
R13	SMC Resistor, 21.0 Ω , 1 W, 1%	Dale	WSC-1

1. Kemet is a registered trademark of Kemet Laboratories Company, Inc.
2. Philips is a registered trademark of Philips Manufacturing Company.
3. Vitramon is a registered trademark of Vitramon, Inc.
4. Hewlett Packard is a registered trademark of Hewlett-Packard Company.
5. Polyswitch is a registered trademark of Raychem Corporation.
6. Bel and Bel Fuse are registered trademarks of Bel Fuse, Inc.
7. Molex is a registered trademark of Molex, Inc.
8. Dale is a registered trademark of Dale Electronics, Inc.

Application Briefs (continued)

T7237 Reference Circuit (continued)

Table 23. T7237 Reference Schematic Parts List (continued)

Reference Designator	Description	Source	Part #
R14, 15	SMC Resistor, 1.1 k Ω , 2 W, 5%	Dale	WSC-2
T1	ISDN U-interface Trans- former	Lucent	2754H2 Alternates (See footnote at the end of this table.): Lucent 2754K2 (1500 Vrms breakdown) Lucent 2809A (for EN60950 compliance) Valor ¹⁰ PT4084 (619) 537-2500 Midcom 671-7759 (605) 886-4385
U1	T7237 IC, 44-pin PLCC	Lucent	—
U2	Optocoupler	Hewlett Packard	HCPL-0701
U3	ISDN dc Termination IC	Lucent	LH1465AB
VR1	Transient Voltage Suppressor	SGS-Thomson ¹¹	SM6T6V8CA Alternates: Motorola SA6.5CA, P6KE6.8CA, P6KE7.5CA
VR2	Transient Voltage Suppressor	SGS-Thomson	SMP100-140 Alternate: Teccor ¹² P1602AB (972) 580-7777
X1	15.36 Crystal	Saronix (415) 856-6900	SRX5144 Alternates: MTRON ¹³ 4044-001 (605) 665-9321 2B Elettronica S.D.L. TP0648 39-6-6622432

9. Valor is a registered trademark of Valor Electronics, Inc.

10. Advanced Power Components is a registered trademark of Advanced Power Technology, Inc.

11. SGS-Thomson is a registered trademark of SGS-Thomson Microelectronics, Inc.

12. Teccor is a registered trademark of Teccor, Inc.

13. MTRON is a registered trademark of MTRON Industries, Inc., a wholly owned subsidiary of Lynch* Corporation.

* Lynch is a registered trademark of Lynch Corporation.

Note: The Lucent 2754K2 and the Valor PT4084 have different winding resistances than the Lucent 2754H2, and therefore require a change to the line-side resistor (R15). In addition, if the Bel Fuse is used in place of the Raychem TR600-150 PTC at location F1 (which will sacrifice the resettable protection that the PTC provides), the line-side resistors must be adjusted to compensate for reduced resistance due to the removal of the PTC (12 Ω). The following table lists the necessary resistor values for these cases. Note that R15 is specified at 1%. This is due to the fact that the values were chosen from standard 1% resistor tables. When a PTC is used, the overall tolerance will be greater than 1%. This is acceptable, as long as the total line-side resistance is kept as close as possible to the ideal value. See Questions and Answers section, #11 for more details.

Table 24. Line-Side Resistor Requirements

Transformer	When Raychem TR600-150 Is Used	When Bel Fuse Is Used
	R13	R13
Lucent 2754H2	21 Ω	33.2 Ω
Lucent 2754K2	15.4 Ω	27.4 Ω
Lucent 2809A	9.53	21.5
Valor PT4084	0 Ω	10.7 Ω

Application Briefs (continued)

Using the T7237 in a TA Environment

The T7237 is designed for uses in applications requiring U terminal adapter (TA) functionality (i.e., terminating the U-interface to a local voice or data controller where no S/T-interface is required). This application brief describes a typical U-terminal adapter application. A block diagram of this application is shown in Figure 18. The microprocessor (μ P) performs the following functions:

- Runs the ISDN call control stack (Q.931).
- Controls the HDLC formatter for performing the LAP-D protocol on the D channel.
- Controls the register configuration of the T7237.
- Controls the POTS circuitry (i.e., translates signaling such as off-hook into the correct call-control message, translates DTMF digits from a DTMF receiver, controls the ringer, etc.).
- Controls access to the B and D channels on the TDM highway for the codecs and HDLC formatter, respectively.

T7237 Configuration

For activation and data transparency to occur, the T7237 must first be configured to properly transmit and receive data. This is accomplished by setting up the appropriate registers via the serial up interface, as follows:

1. Set TDMEN = 0 (register GR2, bit 5) to enable the TDM highway.
2. Set register DFR0 = F5h to enable the transmit B channels on the TDM highway.
3. Set register DFR1 = 1Eh to enable the transmit D channel on the TDM highway and to enable the receive (downstream) 2B+D channels on the TDM highway. Bits 7—5 of DFR1 can be used to 3-state the individual B & D receive channels as required by the application.
4. Configure the frame strobe position and polarity by setting register TDR0 as required by the application (the default is a positive polarity pulse that envelopes the B1 channel).

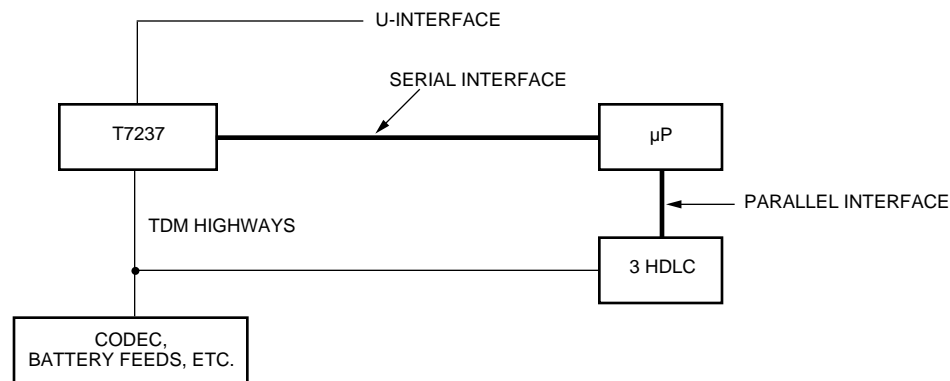

5-3646(C).a

Figure 18. T7237 TA Application Block Diagram

Application Briefs (continued)**T7237 Configuration** (continued)**Activation Control**

Because there is no guarantee that a TE will be connected in this application, the local microprocessor must be provisioned to perform a layer-1 activation request as follows:

1. Write $AUTOACT = 0$ (register GR0, bit 6) to initiate start-up on the U-interface. This results in $XACT = 1$ (register CFR1, bit 1). The $AUTOACT$ bit will be set to a 1 automatically after the start-up request is made. This permits another activation attempt by writing $AUTOACT = 0$ again (without first writing it back to 1) if the start-up attempt fails.

A switch-initiated start-up is detected by the local microprocessor when $XACT = 1$ (register CFR1, bit 1). This event can be indicated by an interrupt (INT, pin 11) by writing the interrupt mask bit $OUSCM = 0$ (register UIR1, bit 3) and calling the interrupt routine when $UINT = 1$ (register GIR0 bit 0). The $OUSC$ interrupt (register UIR0, bit 3) indicates a bit change in either CFR1 or CFR2. Read these registers to determine which of these bits has changed since the last read.

In either of the above cases, it may be necessary to set the $sai[1:0]$ bits in register GR1 to 01. This has the effect of indicating S/T-interface activity to the switch even when no TE is attached. Some switches require the reception of $sai = 1$ in order to properly establish layer-1 transparency.

2. Look for $XACT = 0$ or $OOF = 1$ (register CFR1, bits 1 and 2). These events can be indicated by an interrupt INT, pin 11) in a similar manner as described in (1) above.
3. If $XACT = 0$, the start-up attempt has failed and appropriate action should be taken depending on the system requirements (it may be desirable to attempt another start-up).
4. If $OOF = 1$, U-interface synchronization is complete. Set $ACTT = 1$ (register GR1, bit 4). This will set the upstream $ACT = 1$ on the U-interface.
5. After setting $ACTT = 1$, wait for $ACTR = 1$ (register CFR1, bit 0). This event can be indicated by an interrupt (INT, pin 11) in a similar manner as described in (1) above. The reception of $ACTR = 1$, enables U-interface transparency in the upstream direction, so it is not necessary to do so explicitly by setting $XPCY = 0$ (register GR1, bit 5).

At this point, layer-1 activation is complete. After layer 1 activation is complete, the $XACT$ bit (register CFR1, bit 1) can be monitored for a state change to 0. This provides an indication to the local microprocessor that layer 1 has deactivated. When this occurs, set $XPCY = 1$ (register GR1, bit 5) and $ACTT = 0$ (register GR1, bit 4) to prepare for the next start-up attempt.

Application Briefs (continued)

Interfacing the T7237 to the Motorola 68302

Introduction

The Motorola MC68302 integrated multiprotocol processor (IMP) contains a 68000 core integrated with a flexible communications architecture. It has three serial communications controllers (SCCs) that can be independently programmed to support the following protocols and physical interfaces.

Table 25. Motorola MC68302 SCC Options

Protocols	Physical Interfaces
HDLC/SDLC	Motorola IDL
UART	GCI
BISYNC	PCM Highway
DDCMP	NMSI (nonmultiplexed serial interface)
V.110 Rate Adaption	—
Transparent	—

The PCM interface option of the SCCs is appropriate for interfacing to the T7237 TDM highway to provide access to B- and D-channel data. The SCCs allow ISDN B-channel transfers that support applications such as V.120 rate adaption (synchronous HDLC mode) and voice storage (transparent mode). However, the T7237 does not output all signals that are required to connect directly to the SCC and some external circuitry (e.g., a PAL) is required in order to interface the T7237 TDM highway to the MC68302 SCC PCM highway. Users of the Motorola MC68360 should note that the T7237 can be connected directly to the PCM highway of the MC68360 without the use of any such glue logic.

The MC68302 contains a 3-wire serial interface called an SCP (serial communications port). The SCP may be directly connected to the T7237 serial microprocessor interface to control the T7237 register configuration. The MC68302 also has programmable ports A (16 bits) and B (12 bits) that are bit-wise programmable and can be used as an alternative to the SCP to drive the T7237 serial microprocessor interface.

Figure 19 illustrates the interface connections between the MC68302 and the T7237. A discussion of the TDM and microprocessor interfaces follows.

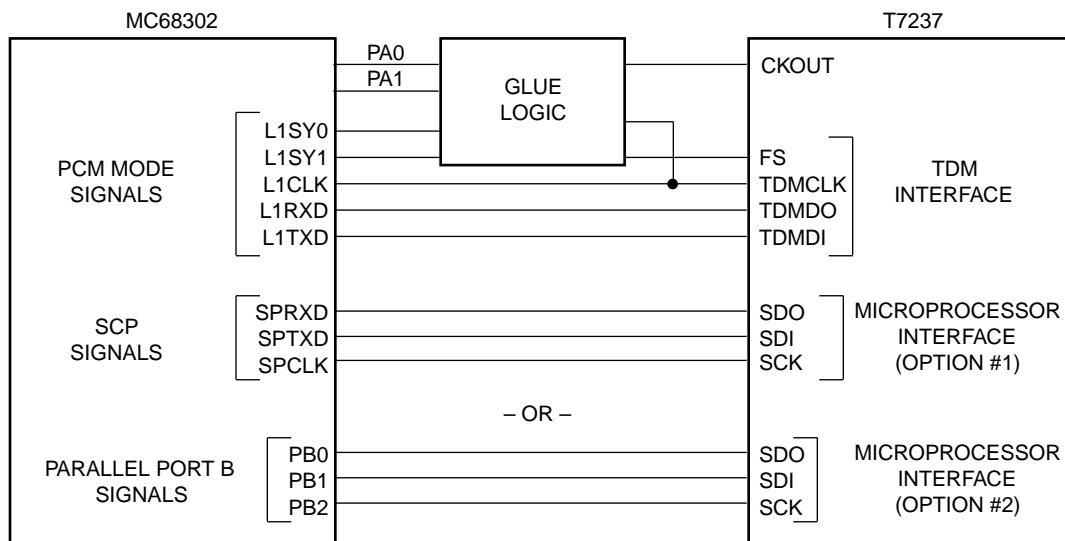

5-4046(C).a

Figure 19. MC68302 to T7237 Interface Diagram

Application Briefs (continued)**Interfacing the T7237 to the Motorola 68302** (continued)**Using the Motorola MC68302 PCM Mode to Interface to the T7237 TDM Highway**

In PCM mode, any number of the MC68302 internal SCCs can be multiplexed to support a TDM type of interface (see Section 4.4.3, PCM Highway Mode in the MC68302 Data Book). The SCCs in PCM mode require a data-in lead (L1RXD) for receive data, a data-out lead (L1TXD) for transmit data, and a common receive and transmit data clock to clock data into and out of the SCCs (L1CLK). These signals are directly compatible with the T7237 TDM highway. In addition, the PCM-mode SCCs require two data synchronization signals, L1SY1 and L1SY0, which route specific TDM time slots to the SCCs. These signals are not directly supported by T7237, and some glue logic is required to generate them.

To interface to the T7237 TDM highway B- and D-channel time slots, the L1SY1 and L1SY0 signals must be 8 bits in length for the B1 and B2 channels, and 2 bits in length for the D channel. The MC68302 PCM channel selection criteria for the L1SY0 and L1SY1 signals are presented in the following table.

Table 26. Channel Selection Criteria

L1SY0	L1SY1	Channel Accessed
0	0	None
1	0	U-interface B1 channel — active for 8 bits
0	1	U-interface B2 channel — active for 8 bits
1	1	U-interface D channel — active for 2 bits

Figures 20 and 21 illustrate a circuit and the corresponding timing diagram for generating the L1SY0 and L1SY1 signals. This circuit can be implemented on an

EPLD such as an Altera* Ep610 or an ICTPA7024. The T7237 TDM signals FS and TDMCLK are used as inputs to the circuit, and the outputs are L1SY0 and L1SY1. In addition, two optional codec frame strobe outputs for B1 and B2 channel data are shown that allow one or two codecs to share the TDM highway PCM interface. The codec frame strobes are enabled only when the codecs are in use to prevent them from interfering with the data transmission on the TDM highway when the codecs are not in use.

To enable the TDMCLK and FS signals and generate the FS signal in the proper time slot, the following T7237 register bits must be programmed:

Register GR2 bit 5 (TDMEN) = 0.

Register DFR0 bits 3:0 (UXB2[1:0] and UXB1[1:0]) = 0101.

Register DFR1 bit 0 (UXD) = 0.

Register DFR1 bits 7:5 (TDMDU, TDMB2U, TDMB1U) = 000.

Register TDR0, bits 3:0 (FSP, FSC[2:0]) = 1111 (default).

Detailed information on T7237 activation control and configuration of the microprocessor registers can be found in the Application Briefs, Using the T7237 in a TA Environment section in this document.

As an example of programming the MC68302 SIMODE register bits for PCM mode, the following settings will enable PCM mode and route the B2 channel to SCC1, the B1 channel to SCC2, and the D channel to SCC3. The ISDN signaling protocol stack (Q.931 and LAPD) would communicate via SCC3, and any higher-layer data protocol such as V.120 or V.110 would communicate via SCC1 and SCC2, as required.

SETZ = 0, SYNC = 1, SDIAG1:SDIAG0 = 00, SDC2 = 0, SDC1 = 0, B2RB:B2RA = 01, B1RB:B1RA = 10, DRB:DRA = 11, MSC3 = 0, MSC2 = 0, and MS1:MS0 = 01.

*Altera is a registered trademark of Altera Corporation.

Application Briefs (continued)

Interfacing the T7237 to the Motorola 68302 (continued)

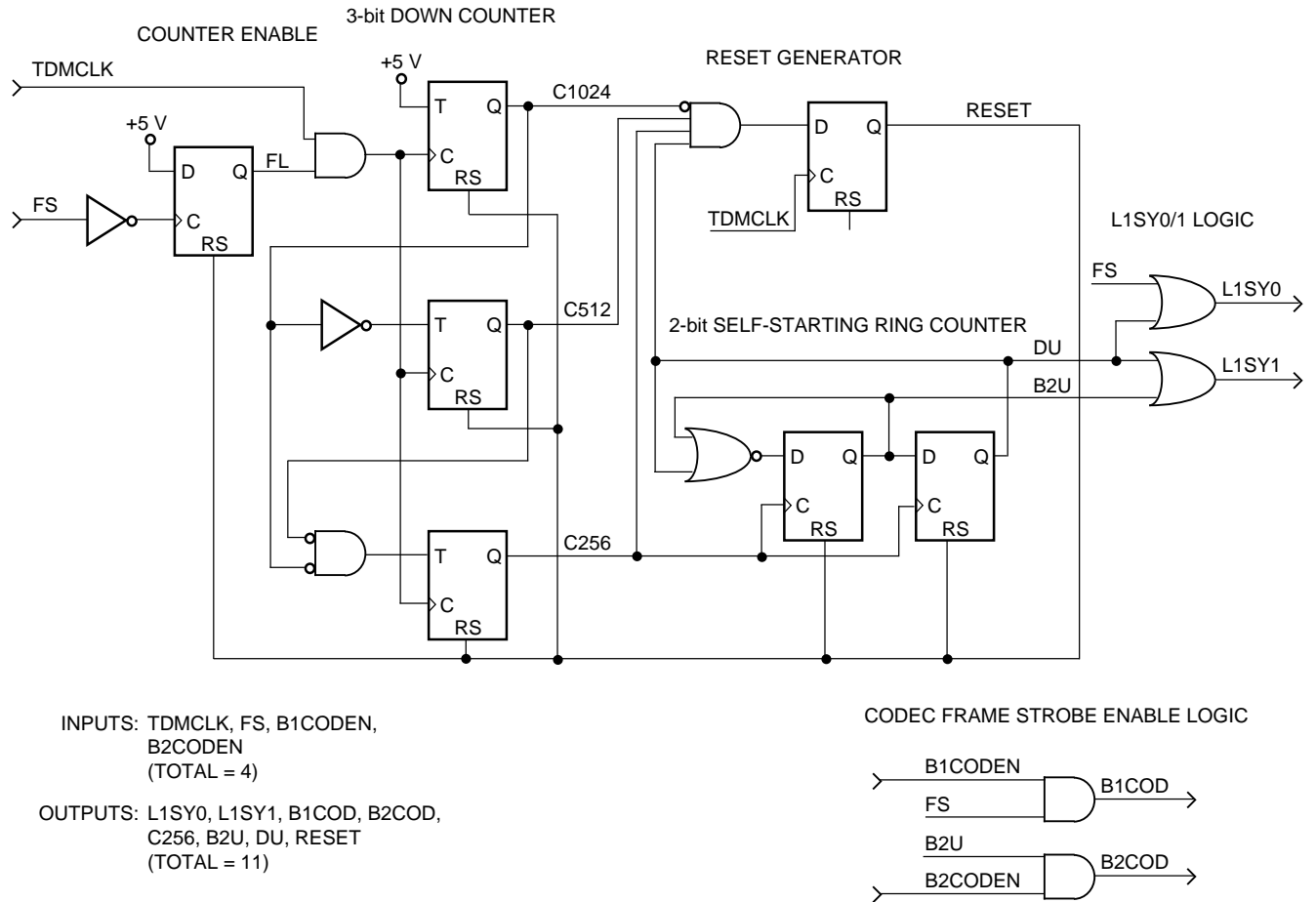

5-4049 (C)

Figure 20. T7237/MC68302 Interface Circuit

Application Briefs (continued)

Interfacing the T7237 to the Motorola 68302 (continued)

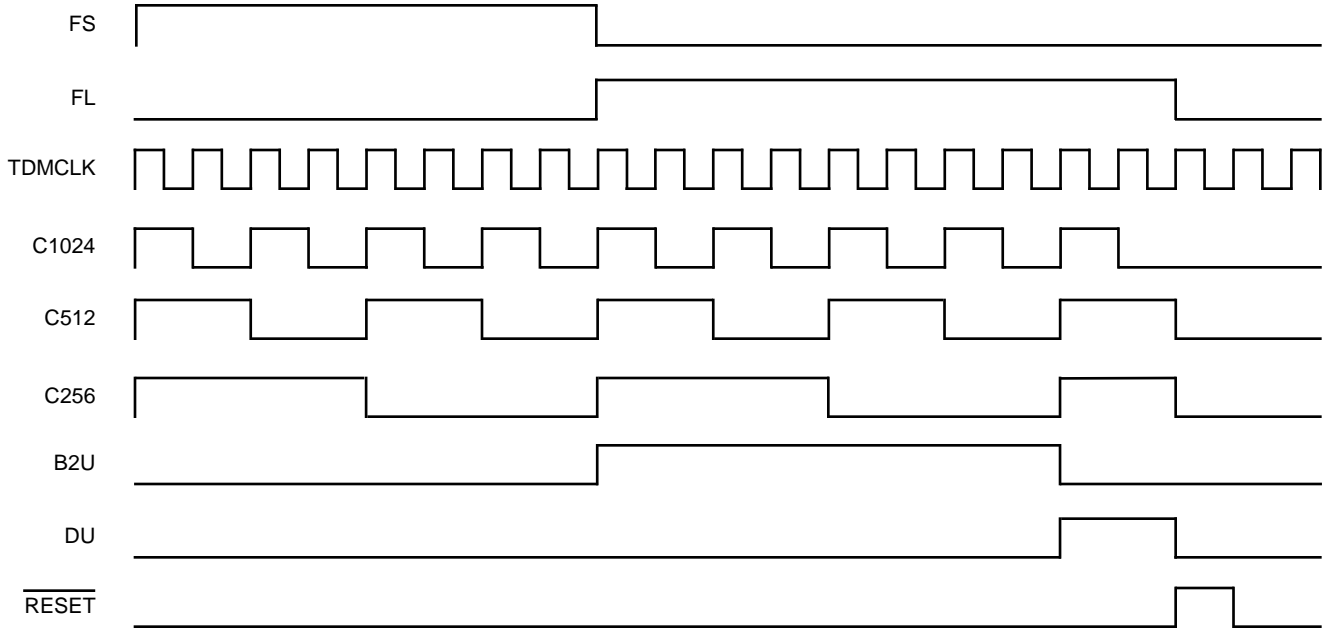

5-4050 (C)

Figure 21. T7237/MC68302 Interface Timing

Application Briefs (continued)

Interfacing the T7237 to the Motorola 68302 (continued)

T7237 Serial Microprocessor Interface Support

The MC68302 SCP interface is a 3-wire serial interface that may be directly connected to the T7237 microprocessor interface. The SCP interface is implemented in the MC68302 hardware, and the only software interaction required is to set up the SCP interface, to transmit/receive SCP bytes, and to respond to SCP events (the SCP interrupt).

There are several points to note when interfacing the T7237 to the MC68302 microprocessor interface.

1. Register bit CI (clock invert) in the MC68302 SPMODE register should be set to 1 to invert the MC68302 SCP clock in order to meet the T7237 microprocessor timing specifications.
2. The MC68302 SCP clock, SPCLK, may be programmed to run as high as 4.096 MHz. The minimum rate of the SCP SPCLK, assuming the slower 16.384 MHz version of the MC68302 with a maximum divide-down prescale of 64, is 256 kHz. The minimum and maximum rates of the T7237 SCK are 60 kHz and 960 kHz, respectively, and care should be taken to ensure that the MC68302 is programmed to a clock rate that is compatible with T7237.
3. Every T7237 access consists of two 8-bit transfers, where the first is the command/address byte and the second is the data byte. There must be a delay

of 10 μ s between every 8-bit register access to meet the T7237 microprocessor timing specifications. The back-to-back byte transmit delay of the MC68302 SCP at the slowest SPCLK rate of 256 kHz can be anywhere from two to eight clocks, or 7.8 μ s to 31.25 μ s. To ensure that the 10 μ s delay requirement is met, the MC68302 software must not send the second byte of the 2-byte sequence for at least 10 μ s after the SCP processor clears the DONE bit in the SCP transmit/receive buffer descriptor (refer to Section 4.6.2 of the Motorola MC68302 User Manual for further information).

4. During 2-byte data transfer over the MC68302 SCP, 8 bits will be shifted into the SCP receive buffer for every 8 bits shifted out. For a T7237 read, the first byte in the receive buffer should be discarded and the second byte will contain the read data from the T7237. For a write, both bytes should be discarded from the SCP receive buffer.
5. The T7237 microprocessor interface lacks an enable pin to permit multiple device communication on a single MC68302 SCP. In these applications, the T7237 microprocessor interface can be enabled/disabled using a microprocessor parallel port pin to control a 3-state buffer at SCK (pin 15).

An alternative method of interfacing the MC68302 to the T7237 microprocessor interface is to use three MC68302 parallel port pins (e.g., PB0, PB1, and PB2 in Figure 19) programmed as outputs and supporting the T7237 microprocessor interface in software. The timing of the SCK, SDI, and SDO signals can be implemented in software with a minimum amount of code.

Absolute Maximum Ratings

Stresses in excess of the absolute maximum ratings can cause permanent or latent damage to the device. These are absolute stress ratings only. Functional operation of the device is not implied at these or any other conditions in excess of those given in the operation sections of the data sheet. Exposure to absolute maximum ratings for extended periods can adversely affect device reliability.

External leads can be soldered safely at temperatures up to 300 °C.

Parameter	Symbol	Min	Max	Unit
dc Supply Voltage Range	V _{DD}	-0.5	6.5	V
Power Dissipation (package limit)	P _D	—	800	mW
Storage Temperature	T _{stg}	-55	150	°C
Voltage (any pin) with Respect to GND	—	-0.5	6.5	V

Handling Precautions

Although protection circuitry has been designed into this device, proper precautions should be taken to avoid exposure to electrostatic discharge (ESD) during handling and mounting. Lucent employs a human-body model (HBM) and charged-device model (CDM) for ESD-susceptibility testing and protection design evaluation. ESD voltage thresholds are dependent on the circuit parameters used to define the model. No industry-wide standard has been adopted for the CDM. However, a standard HBM (resistance = 1500 Ω, capacitance = 100 pF) is widely used and, therefore, can be used for comparison. The HBM ESD threshold presented here was obtained by using these circuit parameters:

ESD Threshold Voltage	
Device	Voltage
T7237-ML2	>1000

Recommended Operating Conditions

Parameter	Symbol	Test Conditions	Min	Typ	Max	Unit
Ambient Temperature	T _A	V _{DD} = 5 V ± 5%	-40	—	85	°C
Any V _{DD}	V _{DD}	—	4.75	5.0	5.25	V
GND to GND	V _{GG}	—	-10	—	10	mV

Electrical Characteristics

All characteristics are for a 15.36 MHz crystal, 135 Ω line load, random 2B+D data, $T_A = -40\text{ }^\circ\text{C}$ to $+85\text{ }^\circ\text{C}$, $V_{DD} = 5\text{ V} \pm 5\%$, $GND = 0\text{ V}$, and output capacitance = 50 pF.

Power Consumption

Table 27. Power Consumption

Parameter	Test Conditions	Min	Typ	Max	Unit
Power Consumption	Operating, random data	—	270	350	mW
Power Consumption	Powerdown mode	—	35	50	mW

Pin Electrical Characteristics

Table 28. Digital dc Characteristics (Over Operating Ranges)

Parameter	Symbol	Test Conditions	Min	Max	Unit
Input Leakage Current:					
Low	IILPU	$V_{IL} = 0$ (pins 2, 6, 7, 11, 44)	-52	-10	μA
High	IIHPU	$V_{IH} = V_{DD}$ (pins 2, 6, 7, 11, 44)	—	-10	μA
Low	IILPD	$V_{IL} = 0$ (pins 8, 9, 12, 15, 43)	-10	—	μA
High	IIHPD	$V_{IH} = V_{DD}$ (pins 8, 9, 12, 15, 43)	-10	-52	μA
Input Voltage:					
Low	V_{IL}	All pins except 2, 6, 43	—	0.8	V
High	V_{IH}	All pins except 2, 6, 43	2.0	—	V
Low-to-high Threshold	V_{ILS}	Pin 43	$V_{DD} - 0.5$	—	V
High-to-low Threshold	V_{IHS}	Pin 43	—	0.5	V
Low	V_{ILC}	Pins 2, 6	—	$0.2 V_{DD}$	V
High	V_{IHC}	Pins 2, 6	$0.7 V_{DD}$	—	V
Output Leakage Current:					
Low	IOZL	$V_{OL} = 0$, pin 44 = 0 (pins 3, 14)	—	10	μA
High	IOZH	$V_{OH} = V_{DD}$, pin 44 = 0 (pins 3, 14)	-10	—	μA
Low	IOZLPU	$V_{OL} = 0$, pin 44 = 0 (pin 11)	-52	-10	μA
High	IOZHPU	$V_{OH} = V_{DD}$, pin 44 = 0 (pin 11)	—	10	μA
Low	IOZLPD	$V_{OL} = 0$, pin 44 = 0 (pins 4, 8, 9, 17)	-10	—	μA
High	IOZHDPD	$V_{OH} = V_{DD}$, pin 44 = 0 (pins 4, 8, 9, 17)	10	52	μA
Output Voltage:					
Low, TTL	V_{OL}	$I_{OL} = 4.5\text{ mA}$ (pin 3)	—	0.4	V
		$I_{OL} = 19.5\text{ mA}$ (pins 4, 9)	—	0.4	V
		$I_{OL} = 8.2\text{ mA}$ (pins 8, 17)	—	0.4	V
		$I_{OL} = 6.5\text{ mA}$ (pin 14)	—	0.4	V
		$I_{OL} = 3.3\text{ mA}$ (pin 11)	—	0.4	V
High, TTL	V_{OH}	$I_{OH} = 32.2\text{ mA}$ (pins 4, 9)	2.4	—	V
		$I_{OH} = 13.5\text{ mA}$ (pins 8, 17)	2.4	—	V
		$I_{OH} = 10.4\text{ mA}$ (pins 3, 14)	2.4	—	V
		$I_{OH} = 5.1\text{ mA}$ (pin 11)	2.4	—	V

Electrical Characteristics (continued)**Crystal Characteristics****Table 29. Fundamental Mode Crystal Characteristics**

These are the characteristics of a parallel resonant crystal for meeting the ± 100 ppm requirements of T1.601 for NT operation. The parasitic capacitance of the PC board to which the T7237 crystal is mounted must be kept within the range of $0.6 \text{ pF} \pm 0.4 \text{ pF}$.

Parameter	Symbol	Test Conditions	Specifications	Unit
Center Frequency	F _o	With 25.0 pF of loading	15.36	MHz
Tolerance Including Calibration, Temperature Stability, and Aging	TOL	—	± 70	ppm
Drive Level	DL	Maximum	0.5	mW
Series Resistance	R _s	Maximum	20	Ω
Shunt Capacitance	C _o	—	$3.0 \pm 20\%$	pF
Motional Capacitance	C _M	—	$12 \pm 20\%$	fF

Table 30. Internal PLL Characteristics

Parameter	Test Conditions	Min	Typ	Max	Unit
Total Pull Range	—	± 250	—	—	ppm
Jitter Transfer Function	-3 dB point (NT), 18 kft 26 AWG	—	5*	—	Hz
Jitter Peaking	1.5 Hz typical	—	1.0*	—	dB

* Set by digital PLL; therefore, variations track U-interface line rate.

Timing Characteristics

TA = -40 °C to +85 °C, VDD = 5 V ± 5%, GND = 0 V, crystal frequency = 15.36 MHz. FSC = 001, FSP = 1.

Table 31. TDM Bus Timing

Ref	Parameter	Min	Typ	Max	Unit
1	FS Pulse Frequency	—	8	—	kHz
2	TDMCLK to FS High	—	—	15	ns
3	TDMCLK to FS Low	—	—	15	ns
4	TDMCLK Frequency	—	2.048	—	MHz
5	TDMCLK Width High	162	230	293	ns
6	TDMCLK Width Low	195	260	326	ns
7	Receive (TDMDI) Setup Time	25	—	—	ns
8	Receive (TDMDI) Hold Time	25	—	—	ns
9	Transmit (TDMDO) Time to High Impedance	—	—	45*	ns
10	TDMCLK to Transmit (TDMDO) Valid	—	—	50	ns

*When connecting the T7237 TDM bus to Lucent devices with a CHI (concentration highway interface), the CHI must be able to withstand 45 ns of bus contention. For this length of time, two devices may be driving the bus. After this time, the output current is less than 10% of the output high and output low currents. The TDMD0 pin on the T7237 was designed to withstand 80 ns of bus contention.

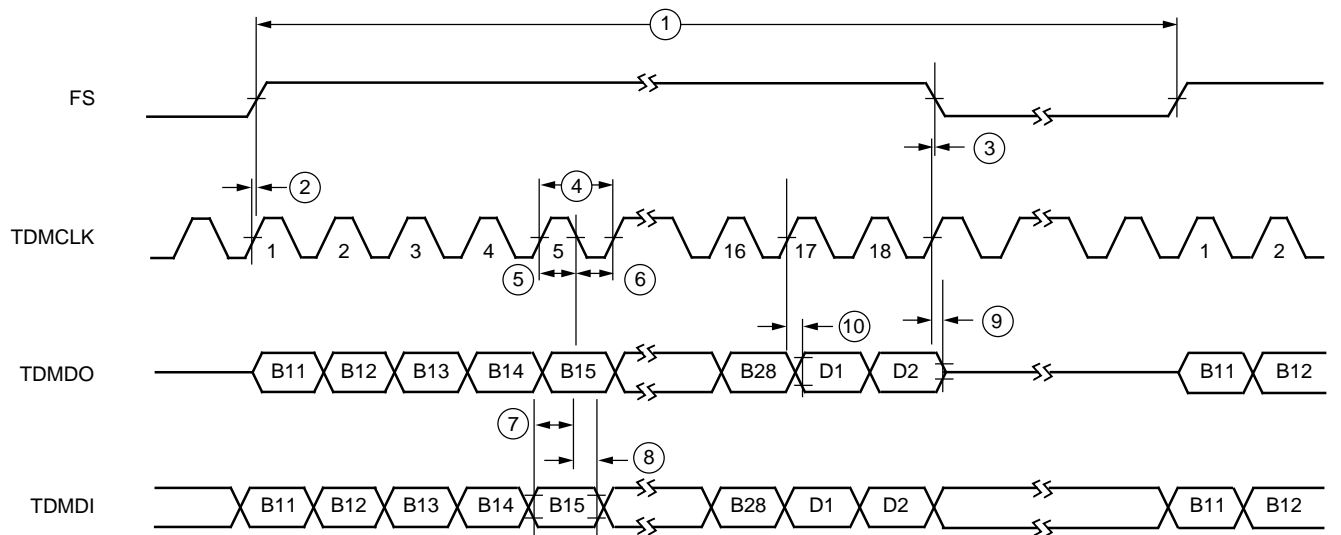

5-4682(C).a

Figure 22. TDM Bus Timing

Timing Characteristics (continued)

Table 32. Clock Timing (See Figure 23.)

Symbol	Parameter	Min	Typ	Max	Unit
SYN8K	Duty Cycle	49.8	—	50.2	%
CKOUT	Duty Cycle:				
	In 15.36 MHz Mode	40	—	60	%
	In 10.24 MHz Mode	23*	—	52*	%
tR1, tF1	Rise or Fall Time	—	30	—	ns
tCOLFH	CKOUT Clock to Frame Sync (SYN8K)	—	—	50	ns
tR2, tF2	CKOUT Clock Rise or Fall	—	15	—	ns

* Includes the effect of phase steps generated by the digital phase-locked loop.

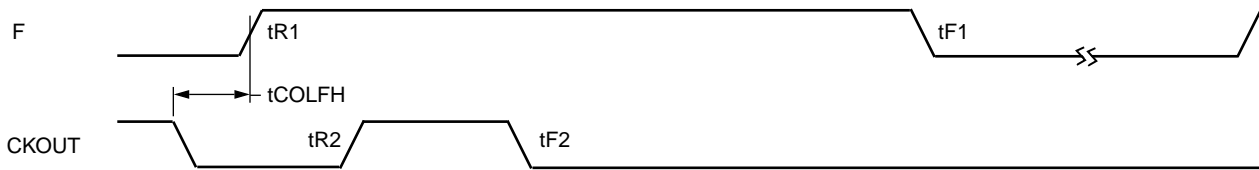

5-3460 (C)

Figure 23. Timing Diagram Referenced to F

Table 33. RESET Timing

Parameter	Description	Min	Max	Unit
tRSLFL, tFLRSH	RESET Setup and Hold Time	60	—	ns
tRSLRSH	RESET Low Time:			
	From Idle Mode or Normal Operation	375	—	μs
	From Power-on	1.5	—	ms

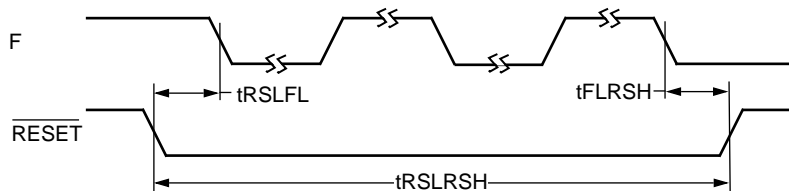

5-3462 (C)

Figure 24. RESET Timing Diagram

Timing Characteristics (continued)

Switching Test Input/Output Waveform

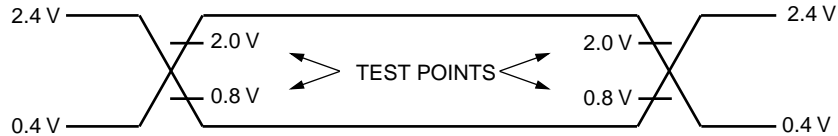

5-2118 (F)

Figure 25. Switching Test Waveform

Figure 25 assumes that pin 12 (SDI) is low when $\overline{\text{RESET}}$ is asserted. The meaning of the setup and hold times t_{RSLFL} and t_{FLRSH} is as follows.

From the time $\overline{\text{RESET}}$ goes low, the following events must occur:

1. A falling edge of SYN8K must occur that meets the setup time with respect to $\overline{\text{RESET}}$ falling edge.
2. At least two additional falling edges of SYN8K (i.e., frames) must occur.
3. A falling edge of SYN8K must occur that meets the hold time with respect to $\overline{\text{RESET}}$ rising edge.

If $\overline{\text{RESET}}$ is asserted asynchronously to SYN8K (which will typically be the case), its falling edge may violate the setup time with respect to SYN8K. Therefore, an additional frame time (125 μs) will elapse before a falling edge of SYN8K occurs that will satisfy criterion #1, above. This means, that to guarantee the $\overline{\text{RESET}}$ requirements are met for parameter t_{RSLRSH} , $\overline{\text{RESET}}$ should be held low for a minimum of 500.120 μs (4 frames + 1 setup time + 1 hold time).

Outline Diagram

44-Pin PLCC

Controlling dimensions are in inches.

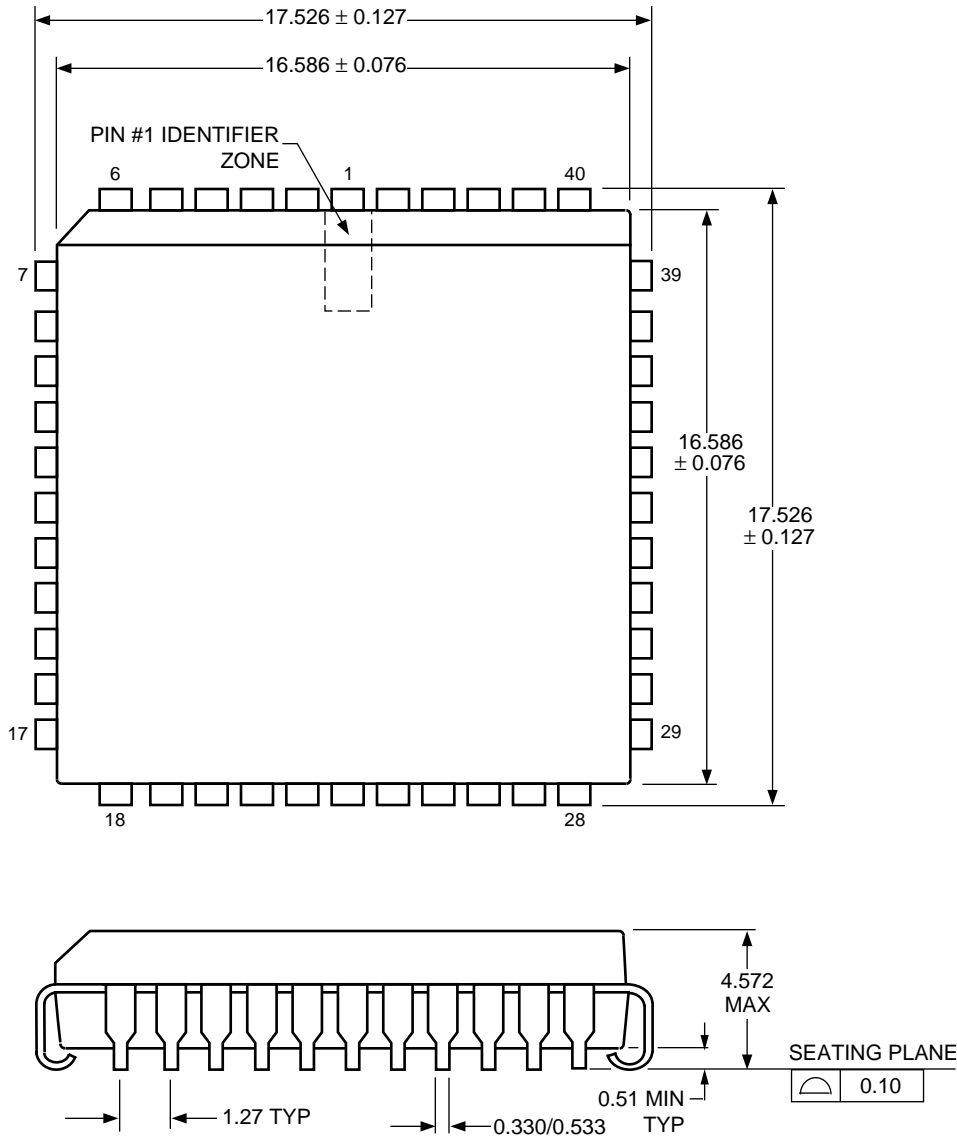

5-2506r8

Note: The dimensions in this outline diagram are intended for informational purposes only. For detailed schematics to assist your design efforts, please contact your Lucent Technologies Sales Representative.

Ordering Information

Device Code	Shipping Method	Package	Temperature	Reliability	Comcode
T7237A - -ML-D	Dry Pack—Sticks	44-Pin PLCC	-40 °C to +85 °C	—	108100678
T7237A - -ML-DT	Dry Pack—Tape & Reel	44-Pin PLCC	-40 °C to +85 °C	—	108101908

Questions and Answers

Introduction

This section is intended to answer questions that may arise when using the T7237 U-interface Transceiver.

The questions and answers are divided into two categories: U-interface and miscellaneous.

U-Interface

- Q1:** Is the line interface for the T7237 the same as for the T7264?
- A1:** Yes. The U-interface section on these chips is identical, so their line interfaces are also identical.
- Q2:** Why is a higher transformer magnetizing inductance used (as compared to other vendors)?
- A2:** It has been determined that a higher inductance provides better linearity. Furthermore, it has been found that a higher inductance at the far end provides better receiver performance at the near end and better probability of start-up at long loop lengths.
- Q3:** Can the T7237 be used with a transformer that has a magnetizing inductance of 20 mH?
- A3:** The echo canceler and tail canceler are optimized for a transformer inductance of approximately 80 mH and will not work with lower inductance transformers.
- Q4:** Are the Lucent Technologies U-interface transformers available as surface-mount components?
- A4:** Not at this time.
- Q5:** Are there any future plans to make a smaller height 2-wire transformer?
- A5:** Due to the rigid design specifications for the transformer, vendors have found it difficult to make the transformer any smaller. We are continuing to work with transformer vendors to see if we can come up with a smaller solution.
- Q6:** The line interface components' specifications require 16.9 Ω resistors on the line side of the transformer when using the 2754H2. For our application, we would like to change this value. Can the U-interface line-side circuit be redesigned to change the value of the line-side resistors?
- A6:** Yes. For example, the line-side resistances can be reflected back to the device side of the transformer so that, instead of having 16.9 Ω on each side of the transformer, there are no resistors on the line side of the transformer and 24.4 Ω resistors on the device side ($16.9 \Omega + 16.9 \Omega/N^2$, where N is the turns ratio of the transformer). Note that the reflected resistances should be kept separate from the device-side 16.9 Ω resistors, and located between VR1 and T1 in Figure 17. This is necessary because the on-chip hybrid network (pins HP, HN) is optimized for 16.9 Ω of resistance between it and the LOP/LON pins.
- Q7:** Table 23, T7237 Reference Schematic Parts List, states that the 0.1 μF capacitor that is used with the LH1465 (C15) must have an insulation resistance of >2 G Ω . Why?
- A7:** This capacitor is used to set the gate/source voltage for the main transistor in the device. The charging currents for this capacitor are on the order of microamps. Since the currents are so small, it is important to keep the capacitor leakage to a minimum.
- Q8:** The dc blocking capacitor (C16 in Figure 17) specified is 1.0 μF . Can it be increased to at least 2 μF ?
- A8:** This value can be increased to 2 μF without an effect on performance. However, for an NT1 to be compliant with T1.601-1992 Section 7.5.2.3, the dc blocking capacitor must be 1.0 $\mu\text{F} \pm 10\%$.
- Q9:** Why is the voltage rating on 1 μF dc blocking capacitor (C16 in Figure 17) so high (250 V)?
- A9:** In Appendix B of T1.601, the last section states that consideration should be given to the handling of three additional environmental conditions. The third condition listed is maximum accidental ringing voltages of up to -200.5 V peak whose cadence has a 33% duty cycle over a 6 s period.

Questions and Answers (continued)**U-Interface** (continued)**A9:** (continued)

This statement could be interpreted to mean that a protector such as VR2 in Figure 17 should not trip if subjected to a voltage of that amplitude. This interpretation sets a lower limit on VR2's breakover rating. Since capacitor C16 will be exposed to the same voltage as VR2, its voltage rating must be greater than the maximum breakover rating of VR2. This sets an upper limit on the protector breakover voltage. The result is a need for a capacitor typically rated at about 250 V.

However, an argument can be made that it doesn't matter whether VR2 trips under this condition, since it is a fault condition anyway, and a tripped protector won't do any damage to a central office ringer.

The only other similar requirement, then, is found in Footnote 8, referenced in Section 7.5.3 of ANSI T1.601. The footnote implies that the maximum voltage that an NT will see during metallic testing is 90 V. The breakover voltage VR2 must be large enough not to trip during the application of the test voltage mentioned in the footnote. This means that a protector with a minimum breakover voltage of 90 V can be used, that would permit a capacitor of lower voltage rating (e.g., 150 V) to be used. This is the approach we currently favor, although Figure 17 illustrates the more conservative approach.

Q10: What is the purpose of the 3300 pF capacitors (C13 and C14) in Figure 17 in the data sheet?

A10: The capacitors are for common-mode noise rejection. The ANSI T1.601 specification contains no requirements on longitudinal noise immunity. Therefore, these capacitors are not required in order to meet the specification. However, there are guidelines in IEC 801-6 which suggest a noise immunity of up to 10 V_{rms} between 150 kHz and 250 MHz. At these levels, the 10 kHz tone detector in the T7237 may be desensitized such that tone detection is not guaranteed

on long loops. The 3300 pF was selected to provide attenuation of this common-mode noise so that tone detector sensitivity is not adversely affected. Since the 3300 pF capacitor was selected based only on guidelines, it is not mandatory, but it is recommended in applications which may be susceptible to high levels of common-mode noise. The final decision depends on the specific application.

As for the size of the capacitors, lab tests indicate the following:

1. The performance of the system suffers no degradation until the values are increased to about 0.1 μ F.
2. The return loss at 25 kHz increases with increasing capacitor value.
3. The capacitor value has no effect on longitudinal balance.
4. A large unbalance in the capacitor values did not affect return loss, longitudinal balance, or performance.

Q11: Are there any recommended common-mode filtering parts for the U-interface? I suspect that our product may have emissions problems, and I want to include a provision for common-mode filtering on the U-interface.

A11: The only common-mode filtering parts we have any data on are two common-mode chokes from Pulse Engineering (619) 674-8100 that are intended to help protect against external common-mode noise. The part numbers are PE-68654 (12.5 mH) and PE-68635 (4.7 mH), and in lab experiments, no noticeable degradation in transmission performance was observed. These chokes are typically effective in the frequency range 100 kHz—1 MHz.

As far as emissions are concerned, we don't have a lot of data. We have seen some success with the use of RJ-45 connectors that have integral ferrite beads such as those from Corcom*, Inc., (708) 680-7400. These provide some flexibility in that they have the same footprint as some standard RJ-45 connectors.

* Corcom is a registered trademark of Corcom, Inc.

Questions and Answers (continued)

U-Interface (continued)

Q12: I am planning on using a Raychem PTC (p/n TR600-150) on the U-interface of the T7237 as shown in Figure 17. The device is rated at 6 Ω—12 Ω. I am concerned about the loose tolerance on the PTC resistance. Will I be able to pass the return loss requirements in ANSI T1.601 Section 7.1?

A12: The NT1 impedance limits looking into tip/ring are derived from the T1.601 return loss requirements (Figure 14 in T1.601). At the narrowest point in the templates, the permissible range is between 111 Ω to 165 Ω. The tolerance on the PTC will reduce the impedance margin somewhat, but should still be acceptable.

Figure 26 is derived from the return loss template in ANSI T1.601. Return loss is a measure of the match between two impedances on either side of a junction point. The following equation is an expression of return loss in terms of the complex impedances of the two halves of the circuit Z₁, Z₂.

$$RL \text{ (dB)} = 20 \log \left| \frac{Z_1 + Z_2}{Z_1 - Z_2} \right|$$

When the impedances are not matched, the junction becomes a reflection point. For a perfectly matched load, the return loss is infinite, whereas for an open or short circuit, the return loss is zero. The return loss expresses the ratio of incident to reflected signal power and should consequently be fairly high.

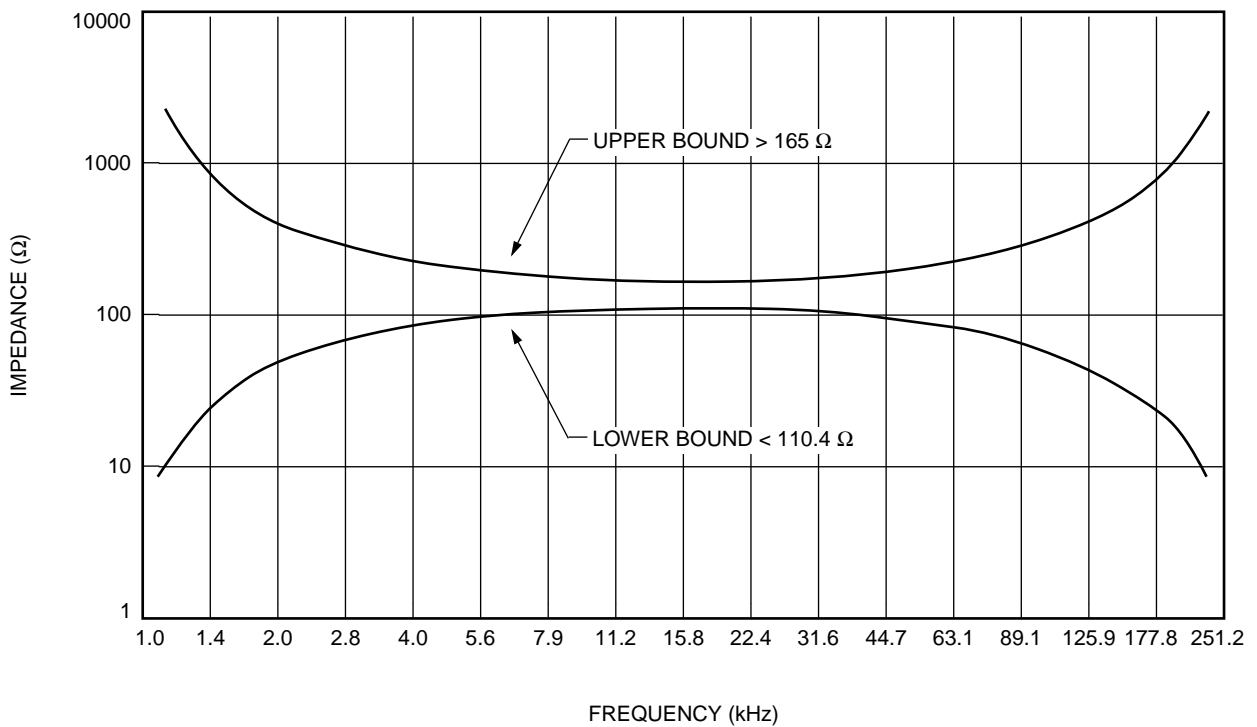

Figure 26. Transceiver Impedance Limits

5-4056 (C)

Questions and Answers (continued)**U-Interface** (continued)**A12:** (continued)

It is desirable to express the return loss in terms of impedance bounds, since an impedance measurement is relatively simple to make. From the above equation, upper and lower bounds on impedance magnitude can be derived as follows:

Z_o = return loss reference impedance = 135 Ω

Z_u = upper impedance curve

Z_L = lower impedance curve

Upper bound ($Z_u > Z_o$):

$$RL \text{ (dB)} = 20 \log \left| \frac{Z_o + Z_u}{Z_u - Z_o} \right|$$

Lower bound ($Z_L < Z_o$):

$$RL \text{ (dB)} = 20 \log \left| \frac{Z_o + Z_L}{Z_u - Z_L} \right|$$

Note that the higher the minimum return loss requirement, the tighter the impedance limits will be around Z_o , and vice versa.

So, for the upper bound, solve for Z_u :

$$Z_u = Z_o \left(\frac{10^{\frac{RL}{20}} + 1}{10^{\frac{RL}{20}} - 1} \right) = |Z_o| \left(\frac{1 + 10^{\frac{-RL}{20}}}{1 - 10^{\frac{-RL}{20}}} \right)$$

For the lower bound, solve for Z_L :

$$Z_u = Z_o \left(\frac{10^{\frac{RL}{20}} - 1}{10^{\frac{RL}{20}} + 1} \right) = |Z_o| \left(\frac{1 - 10^{\frac{-RL}{20}}}{1 + 10^{\frac{-RL}{20}}} \right)$$

Plotting the above equations (using 135 for Z_o and Figure 13 in T1.601 for the RL values) results in the graph shown in Figure 26, which shows the

return loss expressed in terms of impedance upper and lower bounds.

Q13: Why must secondary protection, such as a SGS-Thomson SM6T6V8CA protection diode, be used?

A13: The purpose of the diode is to protect against metallic surges below the breakdown level of the primary protector.

Such metallic surges can be coupled through the transformer and could cause device damage if the currents are high. The protector does not provide absolute protection for the device, but it works in conjunction with the built-in protection on the device leads.

The breakdown voltage level for secondary protection devices must be chosen to be above the normal working voltage of the signal and typically below the breakdown voltage level of the next stage of protection. The SM6T6V8CA has a minimum breakdown voltage level of 6.4 V and a maximum breakdown voltage of 7.1 V.

The chip pins that the SM6T6V8CA protects are pins 36 (HP), 31 (HN), 32 (LOP), and 35 (LON). The 16.9 Ω resistors will help to protect pins 32 and 35, but pins 31 and 36 will be directly exposed to the voltage across the SM6T6V8CA. The on-chip protection on these pins consists of output diodes and a pair of polysilicon resistors. These pins have been thoroughly tested to ensure that a 7.1 V level will not damage them; therefore, no third level of protection is needed between the SM6T6V8CA and the HP and HN pins.

The SM6T6V8CA has a maximum reverse surge voltage level of 10.5 V at 57 A. Sustained currents this large on the device side of the transformer are not a concern in this application.

Thus, there should never be more than 7.1 V across the SM6T6V8CA, except for possibly an ESD or lightning hit. In these cases, the T7237 is able to withstand at least ± 1000 V (human-body model) on its pins.

Questions and Answers (continued)

U-Interface (continued)

- Q14:** Where can information be obtained on lightning and surge protection requirements for 2B1Q products?
- A14:** Requirements vary among applications and between countries. ANSI T1.601, Appendix B, provides a list of applicable specifications to which you may refer. Also, there are many manufacturers of overvoltage protection devices who are familiar with the specifications and would be willing to assist in surge protection design. The ITU-T K series recommendations are also a good source of information on protection, especially recommendation K.11, "Principles of Protection Against Overvoltages and Overcurrents," which presents an overview of protection principles. Also refer to the application notes mentioned in the U-interface Description section of this data sheet.
- Q15:** ITU-T specification K.21 describes a lightning surge test for NT1s (see Figure 1/K.21 and Table 1/K.21, Test #1) in which both tip and ring are connected to the source and a 1.5 kV voltage surge is applied between this point and the GND of the NT1. What are the protection considerations for this test? Are the HP and HN pins susceptible to damage?
- A15:** The critical component in this test is the transformer since its breakdown voltage must be greater than 1.5 kV. Assuming this is the case, the only voltage that will make it through to the secondary side of the transformer will be primarily due to the interwinding capacitance of the transformer coils. This capacitance will look like an impedance to the common-mode surge and will therefore limit current on the device side of the transformer. The device-side voltage will be clamped by the SM6T6V8CA device. The maximum breakdown voltage of the SM6T6V8CA is 7.1 V. The 16.9 Ω resistors will help protect the LOP and LON pins on the T7237 from this voltage. However, this voltage will be seen directly on pins 36 and 31 (HP and HN) on the T7237. The on-chip protection on these pins consists of output diodes and a pair of polysilicon resistors. These pins have been thoroughly tested to

ensure that an 7.4 V level will not damage them; therefore, no third level of protection is needed between the SM6T6V8CA and the HP and HN pins.

- Q16:** Can the range of the T7237 on the U-interface be specified in terms of loss? What is the range over straight 24 awg wire?

- A16:** ANSI Standard T1.601, Section 5.1, states that transceivers meeting the U-interface standard are intended to operate over cables up to the limits of 18 kft (5.5 km) 1300 Ω resistance design. Resistance design rules specify that a loop (of single- or mixed-gauge cable; e.g., 22 awg, 24 awg, and 26 awg) should have a maximum dc resistance of 1300 Ω , a maximum working length of 18 kft, and a maximum total bridged tap length of 6 kft.

The standard states that, in terms of loss, this is equivalent to a maximum insertion loss of 42 dB @ 40 kHz. Lucent Technologies has found that, for assessing the condition of actual loops in the field in a 2B1Q system, specifying insertion loss as 33.4 dB @ 20 kHz more closely models ANSI circuit operation. This is equivalent to a straight 26 awg cable with 1300 Ω dc resistance (15.6 kft).

The above goals are for actual loops in the outside loop plant. These loops may be subjected to noise and jitter. In addition, as mentioned above, there may be bridge taps at various points on the loop. The T1.601 standard defines 15 loops, plus the null, or 0-length loop, which are intended to represent a generic cross section of the actual loop plant.

A 2B1Q system must perform over all of these loops in the presence of impairments with an error rate of $<1e-7$. Loop #1 (18 kft, where 16.5 kft is 26 awg cable and 1.5 kft is 24 awg cable) is the longest, so it has the most loss (37.6 dB @ 20 kHz and 47.5 dB @ 40 kHz). Note that this is more loss than discussed in the preceding paragraph. The difference is based on test requirements vs. field deployment. The test requirements are somewhat more stringent than the field goal in order to provide some margin against severe impairments, complex bridged taps, etc.

Questions and Answers (continued)

U-Interface (continued)

A16: (continued)

If a transceiver can operate over Loop #1 error-free, it should have adequate range to meet all the other loops specified in T1.601. Loop #1 has no bridged taps, so passing Loop #1 does not guarantee that a transceiver will successfully start up on every loop. Also, due to the complex nature of 2B1Q transceiver start-up algorithms, there may be shorter loops which could cause start-up problems if the transceiver algorithm is not robust. The T7237 has been tested on all of the ANSI loops per the T1.601 standard and passes them all successfully. Two loops commonly used in the lab to evaluate the performance of the T7237 silicon are as follows:

Loop Configuration	Bridge Taps (BT)	Loss @ 20 kHz (dB)	Loss @ 40 kHz (dB)
18 kft, 26 awg	None	38.7	49.5
15 kft, 26 awg	Two at near end, each 3 kft, 22 awg	37.1	46.5

The T7237 is able to start up and operate error-free on both of these loops. Neither of these loops is specified in the ANSI standard, but both are useful for evaluation purposes. The first loop is used because it is simple to construct and easy to emulate using a lumped parameter cable model, and it is very similar to ANSI Loop #1, but the loss is slightly worse. Thus, if a transceiver can start up on this loop and operate error-free, its range will be adequate to meet the longest ANSI loop. The second loop is used because, due to its difficult bridge tap structure and its length, it stresses the transceiver start-up algorithms more than any of the ANSI-defined loops. Therefore, if a transceiver can start up on this loop, it should be able to meet any of the ANSI-defined loops that have bridge taps. Also, on a straight 26 awg loop, the T7237 can successfully

start up at lengths up to 21 kft. This fact, combined with reliable start-up on the 15 kft 2BT loop above, illustrates that the T7237 provides ample start-up sensitivity, loop range, and robustness on all ANSI loops. Another parameter of interest is pulse height loss (PHL). PHL can be defined as the loss in dB of the peak of a 2B1Q pulse relative to a 0-length loop. For an 18 kft 26 awg loop, the PHL is about 36 dB, which is 2 dB worse than on ANSI Loop #1. A signal-to-noise ratio (SNR) measurement can be performed on the received signal after all the signal processing is complete (i.e., at the input to the slicer in the decision feedback equalizer). This is a measure of the ratio of the recovered 2B1Q pulse height vs. the noise remaining on the signal. The SNR must be greater than 22 dB in order to operate with a bit error rate of $<1e-7$. With no impairments, the T7237 SNR is typically 32 dB on the 18 kft/26 awg loop. When all ANSI-specified impairments are added, the SNR is about 22.7 dB, still leaving adequate margin to guarantee error-free operation over all ANSI loops.

Finally, to estimate range over straight 24 awg cable, the 18 kft loop loss can be used as a limit (since the T7237 can operate successfully with that amount of loss) and the following calculations can be made:

Loss of 18 kft, 26 awg loop @ 20 kHz	38.7 dB
Loss per kft of 24 awg cable @ 20 kHz	1.6 dB

$$\frac{38.7 \text{ dB}}{1.6 \text{ dB/kft}} = 24 \text{ kft}$$

Thus, the operating range over 24 awg cable is expected to be about 24 kft.

- Q17:** What does the energy spectrum of a 2B1Q signal look like?
- A17:** Figure A1 (curve P1) in the ANSI T1.601 standard illustrates what this spectrum looks like.

Questions and Answers (continued)

U-Interface (continued)

- Q18:** Please clarify the meaning of ANSI Standard T1.601, Section 7.4.2, Jitter Requirement #3.
- A18:** The intent of this requirement is to ensure that after a deactivation and subsequent activation attempt (warm-start), the phase of the receive and transmit signals at the NT will be within the specified limits relative to what they were prior to deactivation. This is needed so that the LT, upon a warm-start attempt, can make an accurate assumption about the phase of the incoming NT signal with respect to its transmit signal. Note that the T7237 meets this requirement by design because the NT phase offset from transmit to receive is always fixed.
- Q19:** I need a way to generate a scrambled 2B1Q data stream from the T7237 for test purposes (e.g., ANSI T1.601 Section 5.3.2.2, Total Power and Section 7.2, Longitudinal Output Voltage). How can I do this?
- A19:** A scrambled 2B1Q data stream (the SN1 signal described in ANSI T1.601 Table 5) can be generated by pulling $\bar{\text{LOSS}}$ (pin 6) low on the T7237.
- Q20:** We are trying to do a return loss measurement on the U-interface of the T7237 per ANSI T1.601 Section 7.1. We are using a circuit similar to the one you recommend in the data sheet. We have observed the following. When the chip is in FULL RESET mode (powered on but no activity on the U- or S/T-interfaces), the return loss is very low, i.e., the termination impedance appears to be very large relative to 135 Ω and falls outside the boundaries of Figure 19 of ANSI T1.601. However, if we inject a 10 kHz tone before making a measurement, the return loss falls within the template. Why is it necessary to inject the 10 kHz tone in order to get this test to pass? Shouldn't a 135 Ω impedance be presented to the network regardless of the state of the T7237 once it is powered on?
- A20:** The return loss is only relevant when the transmitter section is powered on. When the transmitter is powered, it presents a low-impedance output to the U-interface. The transmitter must be held in this low-impedance state when the return loss **and** longitudinal balance tests are performed. This can be accomplished by pulling RESET low (pin 43). With the RESET pin held low, the transmitter is held in a low-impedance state where each of its differential outputs drives DV. In this state, it is prevented from transmitting any 2BIQ data and won't respond to any incoming wakeup tones. This is different than the ANSI-defined FULL RESET state that the chip enters after power-on or deactivation. In FULL RESET, the transmitter is powered down and in a high-impedance state, with only the tone detector powered on and looking for a far-end wakeup tone. The transmitter powers down when in FULL RESET state to save power and maximize the tone detector sensitivity. The reason that the chip behaves as it does in your tests is that your test begins with the transmitter in its FULL RESET state, causing the return loss to be very low. If a 10 kHz signal is applied, the tone detector senses the applied signal and triggers. This causes the transmitter to enter its low-impedance state, where it will remain until the T7237 start-up state machine times out (typically within 1.5 seconds, depending on the signal from the far end).
- Q21:** What are the average cold-start and warm-start times?
- A21:** Lab measurements have shown the average cold-start time to be about 3.3 s—4.2 s over all loop lengths, and the average warm-start time to be around 125 ms—190 ms over all loop lengths.
- Q22:** What is the U-interface's response time to an incoming wakeup tone from the LT?
- A22:** Response time is about 1 ms.
- Q23:** What is the minimum time for a U-interface reframe after a momentary (<480 ms) loss of synchronization?
- A23:** Five superframes (60 ms).
- Q24:** Where is the U-interface loopback 2 (i.e., EOC 2B+D loopback) performed in the T7237?
- A24:** It is performed just inside the chip at the S/T-interface. The S/T receiver is disconnected internally from the chip pins, and the S/T transmit signal is looped back to the receiver inputs so the S/T section synchronizes to its own signal. This ensures that as much of the data path as possible is being tested during the 2B+D loopback.
- Q25:** Are the embedded operations channel (EOC) initiated B1 and B2 channel loopbacks transparent?
- A25:** Yes, the B1 and B2 channel loopbacks are transparent, as is the 2B+D loopback.

Questions and Answers (continued)**U-Interface** (continued)

Q26: How can proprietary messages be passed across the U-interface?

A26: The embedded operations channel (EOC) provides one way of doing this. ANSI standard T1.601 defines 64 8-bit messages which can be used for nonstandard applications. They range in value from binary 00010000 to 01000000.

There is also a provision for sending bulk data over the EOC. Setting the data/message indicator bit to 0 indicates the current 8-bit EOC word contains data that is to be passed transparently without being acted on. Note that there is no response time requirement placed on the NT in this case (i.e., the NT does not have to echo the message back to the LT). Also note that this is currently only an ANSI provision and is not an ANSI requirement. The T7237 does support this provision.

Q27: What is the value of the ANSI T1.601 cso and nib bits in the 2B1Q frame?

A27: cso and nib are fixed at 0 and 1, respectively, by the device. This is because the device always has warm-start capability (CSO = 0), and NT1s are required to have nib = 1 per T1.601-1992.

Q28: Are the PS bits controllable from outside the chip?

A28: Yes, the bits are controlled by two pins (8 and 9) on the chip. When the T7237 TDM highway is enabled, these pins change function and become part of the TDM highway and PS1 and PS2 are controlled by register GR1, bits 1 and 2.

Q29: What is the state of the D-echo bit during an EOC 2B+D loopback?

A29: The D-echo bit (SXE, GR2, bit 3) should be set to zero to meet the ITU-T I.430 requirement in Appendix I, Note 4, which states that during a loopback 2 (EOC 2B+D loopback), the NT1 should send INFO4 frames toward the TE with the D-echo channel bits set to binary zero. If AUTOEOC = 1 (register GR0, bit 4), SXE is internally overridden to 0 by the T7237. If AUTOEOC = 0, SXE must be set to 0 by the user.

Miscellaneous

Q30: Is the ± 100 ppm free-run frequency recommendation met in the T7237?

A30: In the free-run mode, the output frequency is primarily dependent on the crystal, not the silicon design. For low-cost crystals, initial tolerance, temperature, and aging effects may account for two-thirds of this budget, and just a couple of pF of variation in load capacitance will use up the rest; therefore, the ± 100 ppm goal can be met if the crystal parameters are well controlled. See the Crystal Characteristics section in this data sheet.

Q31: What happens if Co and Cm of the crystal differs from the specification shown in the Crystal Characteristics table?

A31: None of the parameters should be varied. We have not characterized any such crystals, and have no easy method of doing so. A crystal whose parameters deviate from the requirements may work in most applications but fail in isolated cases involving certain loop configurations or other system variations. Therefore, customers choosing to vary any of these parameters do so at their own risk.

Q32: It has been noted in some other designs that the crystal has a capacitor from each pin to ground. Changing these capacitances allows the frequency to be adjusted to compensate for board parasitics. Can this be done with the T7237 crystal? Also, can we use a crystal from our own manufacturer?

A32: For the T7237, these capacitors are located on the chip, so their values are fixed. The advantage to this is that no external components are required. The disadvantage is that board parasitics must be very small. The crystal characteristics section of the data sheet notes that the board parasitics must be within the range of $0.6 \text{ pF} \pm 0.4 \text{ pF}$.

Questions and Answers (continued)

Miscellaneous (continued)

Q33: What clocks are available on the T7237?

A33: The following clocks are available and are always present once enabled, regardless of the state of activation on the U- or S/T-interfaces:

1. SYN8K, pin 4 (8 kHz clock) is enabled by holding SDI (pin 12) low during an external RESET.
2. TDMCLK, pin 9 (2.048 MHz clock) is enabled by writing TDMEN = 0 (register GR2, bit 5).
3. CKOUT, pin 17 (10.24 MHz or 15.36 MHz clock) is enabled by writing register GRO, bit 2 or 1, respectively, to 0. Normally 3-stated.

Note that using clocks 2 or 3 above requires a microprocessor for setting the appropriate configuration.

Q34: I plan to program the T7237 to output 15.36 MHz from its CKOUT pin. Is this clock a buffered version of the 15.36 MHz oscillator clock? I am concerned that if it is not buffered, the capacitive loading on this pin could affect the system clock frequency.

A34: The 15.36 MHz output is a buffered version of the XTAL clock and therefore hanging capacitance on it will not affect the T7237's system clock frequency.

Q35: How does the filtering at the OPTOIN input work?

A35: The signals applied to OPTOIN are digitally filtered for 20 ms. Any transitions under 20 ms will be ignored.

Q36: What is the isolation voltage of the 6N139 optoisolator used in the dc termination circuit of the T7237?

A36: 2500 Vac, 1 minute.

Q37: Can the T7237 operate with an external 15.36 MHz clock source instead of using a crystal?

A37: Yes, by leaving X1 disconnected and driving X2 with an external CMOS-level oscillator.

Q38: What is the effect of ramping down the power-supply voltage on the device? When will it provide a valid reset? This condition can occur when a line-powered NT1's line cord is repeatedly plugged in and removed and plugged in again before the power supply has had enough time to fully ramp-up.

A38: The device's reset is more dependent on the $\overline{\text{RESET}}$ pin than the power supply to the device. As long as the proper input conditions on the $\overline{\text{RESET}}$ pin (see Table 42) are met, the device will have a valid reset. Note that this input is a Schmitt-trigger input.

Q39: Is there a recommended method for powering the T7237? For example, is it desirable to separate the power supplies, etc.?

A39: The T7237 is not extremely sensitive to power-supply schemes. Following standard practices of decoupling power supplies close to the chip and, if power and ground planes are not used, keeping power traces away from high-frequency signals, etc., should yield acceptable results. Separating the T7237 analog power supplies from the digital power supplies near the chip may yield a small improvement, and the same holds true for using power and ground planes vs. discrete traces.

Note that if analog and digital power supplies are separated, the crystal power supply (V_{DDO}) should be tied to the digital supplies (V_{DDD}).

See the SCNTI Family Reference Design Board Hardware User Manual (MN96-011ISDN), Appendix A for an example of a board layout that performs well.

Q40: What are the filter characteristics of the PLL at the NT?

A40: The -3 dB frequency is approximately 5 Hz, peaking is about 1.2 dB.

Q41: Can you provide detailed information on the active and idle power consumption of the T7237?

A41: The IDLE power of the T7237 is typically 35 mW. The IDLE power will be increased if CKOUT or the TDM highway is active. The discussion below presents accurate numbers for adding in the effects of CKOUT and the TDM highway.

Questions and Answers (continued)**Miscellaneous** (continued)**A41:** (continued)

When considering active power measurement figures, it is important to note that the conditions under which power measurements are made are not always completely stated by 2B1Q IC vendors. For example, loop length is not typically mentioned in the context of power dissipation, yet power dissipation on a short loop is noticeably greater than on a long loop. There are two reasons for the increased power dissipation at shorter loop lengths:

1. The overall loop impedance is smaller, requiring a higher current to drive the loop.
2. The far-end transceiver is closer, requiring the near-end transceiver to sink more far-end current in order to maintain a virtual ground at its transmitter outputs.

The following lab measurements provide an example of how power dissipation varies with loop length for a specific T7237 with its 15.36 MHz CKOUT output disabled (see the following table for information on CKOUT). Note that power dissipation on a 0-length loop (the worst-case loop) is about 35 mW higher than on a loop of >3 kft length—a significant difference. Thus, loop length needs to be considered when determining worst-case power numbers.

Table 34. Power Dissipation Variation

Loop Configuration	Power (mW)
18 kft/26 awg	270
6 kft/26 awg	270
3 kft/26 awg	274
2 kft/26 awg	277
1 kft/26 awg	285
0.5 kft/26 awg	293
0 kft	305
135 Ω load, ILOSS or LPBK active, no far-end transceiver*	278

* This is the configuration used by some IC manufacturers.

Also, in the case of the T7237, the use of the output clock CKOUT (pin 17) needs to be considered since its influence on power dissipation is significant. Some applications may make use of this clock, while others may leave it 3-stated. The power dissipation of CKOUT is shown in Table 35.

Table 35. Power Dissipation of CKOUT

CKOUT Frequency (MHz)	Power Due to CKOUT 40 pF Load (mW)	Power Due to CKOUT No Load (mW)
15.36	21.3	11.0
10.24	17.7	9.1

The T7237 TDM highway, when active, can add another 3 mW of power.

Therefore, it is apparent that the conditions under which power is measured must be clearly specified. The methods Lucent has used to evaluate typical and worst-case power consumption are based on our commitment to provide our customers with accurate and reliable data. Measurements are performed as part of the factory test procedure using automated test equipment. Bench top tests are performed in actual T7237-based systems to correlate the automated test data with an actual implementation. A conservative margin is then added to the test results for publication in our data sheets.

The following table provides power-consumption data for several scenarios so that knowledgeable customers can fairly compare transceiver solutions. A baseline scenario is presented in the Case 1 column, and then adders are listed in the Cases 2—5 columns to account for the worst-case condition listed in each column so that an accurate worst-case figure can be determined based on the conditions that are present in a particular application. Note that the tests were run at 5 V, so changes in the supply voltage will change the power accordingly.

Questions and Answers (continued)

Miscellaneous (continued)

A41: (continued)

Table 36. Power Consumption

Variables	Baseline	Adders			
	Case 1	Case 2	Case 3	Case 4	Case 5
Loop Configuration	>3 kft, 26 awg	0 kft*	—	—	—
CKOUT, MHz (40 pF load) [†]	3-stated	—	15.36	—	—
Temperature (°C)	25	—	—	85	—
TDM Highway	Inactive	—	—	—	Active
Typical Power Consumption (mW)	254	35	22	5	3

* Some 2B1Q silicon vendors specify power using a configuration in which the IC is active and transmitting into a 135 Ω termination, with no far-end transmitter attached. This configuration would cause an increase of 9 mW over the Case 1 column, instead of the 35 mW shown here. This highlights the importance of specifying measurement conditions accurately when making comparisons between chip vendors' power numbers.

† See the preceding table for a comparison of power dissipation with negligible capacitive loading on CKOUT. The 40 pF figure chosen here is intended to represent a worst-case condition.

Q42: The STLED on my T7237-based NT1 behaves in an unexpected way. When a start-up attempt is received, it flashes at an 8 Hz rate. Then it flashes briefly at 1 Hz, indicating synchronization on the U-interface. This is expected. However, after this, it starts flashing at 8 Hz, and yet it appears as though the system is operating fine (data is being passed end to end, etc.). Shouldn't the STLED signal be always low (i.e., ON) at this point?

A42: Yes it should. Referring to the STLED Control Flow diagram in Figure 15 of this data sheet, it appears as though you may be receiving aib = 0 from the upstream U-interface element. This will cause the behavior you are seeing. If you have access to the microprocessor registers, you can check this by monitoring register CFR1 bit 6 to see if it ever goes to 0.

Q43: We are testing out T7237-based equipment against an Lucent SLC Series 5, and performance seems OK except that we get a burst of errors, and even drop calls, approximately every 15 minutes. Can you explain why?

A43: Check to make sure that your equipment is setting the PS1/PS2 power status bits correctly. The SLC equipment monitors the PS1/PS2 bits and, if they are both zero (meaning all power is lost), it assumes that there is some sort of terminal error, since this is not an appropriate steady-state value for PS1/PS2. When this condition is detected, the SLC deactivates and reactivates the line approximately every 15 minutes. This causes the symptoms you describe.

Questions and Answers (continued)**Miscellaneous** (continued)

- Q44:** What is the state of the T7237 TDM bus output when the unused bits of the D-channel octet are transmitted?
- A44:** The T7237 3-states the TDM bus output when B- and D-channel information is not transmitted to the TDM bus. This includes the 6-bit interval in the D-channel octet.
- Q45:** What is the purpose of the ACTSEL bit in register GR2 bit 6?
- A45:** This bit is to provide compatibility with the ANSI T1.601 and ETSI ETR 080 standards. The 1992 version of T1.601 (the most recent as of this writing) specifies that, upon a loopback 2 EOC request, the NT1's 2B+D data should be looped back immediately and the upstream (NT-to-LT) act bit should be set to 0. ANSI specified that the upstream act bit should be set to 0 to indicate to the LT that end-to-end data transparency (TE-to-LT) is interrupted during a loopback 2. The fact that 2B+D data is looped back immediately means that upstream data transparency at the NT is established independent of the status of the act bit from the LT. Normally, upstream data transparency at the NT is dependent on act = 1 being received from the LT. The reason that loopback 2 transparency criteria differ is that there is no guarantee that the NT1 will receive act = 1 from the LT. Consider the case where an LT wants to activate the U-interface and perform a loopback 2 test on an NT1 with no TE connected. In this case, the LT will never receive act = 1 since, prior to the loopback 2 request, act = 0 because there is no TE attached, and after the loopback 2 request, act = 0 because layer 1 transparency is interrupted. Since the LT will never receive act = 1 from the NT1, it will never send act = 1 back to the NT1. Since the NT1 receipt of act = 1 normally enables upstream transparency, ANSI chose to make an exception to the data transparency requirements in this case and enable upstream transparency immediately upon receipt of the loopback 2 EOC command at the NT1.

The major difference between the ANSI and ETSI standards with regard to how the NT1 handles a loopback 2 request lies in what happens to the upstream act bit. ANSI's position is that act should be set to 0 because a loopback 2 is an interruption to layer 1 transparency. ETSI's position is that the state of the act bit should only be dependent on whether or not the NT1 is receiving INFO 3 from the TE (this is consistent with ANSI T1.601 paragraph 6.4.6.4 and ETSI ETR 080 paragraph A.10.1.5.1). During a loopback 2, the T7237 will always receive INFO 3 at the S/T-interface (even if there is no TE attached) because it loops back its S/T transmit signal and synchronizes itself to that signal. Therefore, the possibility that LT will never receive act = 1 from the NT does not exist under these rules. As a result, no special exceptions need to be applied to the case of loopback 2 in ETSI. For example, again consider the case where an LT wants to activate the U-interface and perform a loopback 2 test on an NT1 with no TE connected. The NT1 will synchronize to its own S/T signal and detect INFO 3. This will cause act = 1 to be transmitted upstream. The LT will detect act = 1 and set its downstream act = 1. When the NT detects the downstream act = 1, it will enable upstream data transparency. The handling of the act bit and transparency in this case is the same as for a normal activation.

In the ETSI standard, transparency at the NT during loopback 2 is dependent upon the reception of the act bit from the LT, i.e., if act = 1, loopback transparency is established, and if act = 0, loopback data is forced to all 1s. The LT won't send act = 1 until it receives act = 1 from the NT. The NT will not send act = 1 to the LT until it receives an INFO 3 indication (i.e., until its S/T-interface is synchronized as described in the register GR2 ACTSEL bit definition). Thus, data transparency requires that the NT1 set its upstream act bit to 1.

There is a contribution that has been voted onto the ANSI T1E1.4 living list that changes the act bit behavior during loopback 2 to match that specified for ETSI (contribution #T1E1.4/92-089). Thus, the next issue of the T1.601 standard will bring the ANSI and ETSI standards into harmony as pertains to handling of the act bit during a loopback 2.

Glossary

ACTMODE/$\overline{\text{INT}}$:	Act bit mode, serial interface microprocessor interrupt.	CFR0:	Control flow state machine control—maintenance/reserved bits register.
ACTR:	Receive activation register CFR1, bit 0).	CFR1:	Control flow state machine status register.
ACTSC:	Activation/deactivation state change on U-interface (register UIR0, bit 1).	CFR2:	Control flow state machine status—reserved bits register.
ACTSCM:	Activation/deactivation state change on U-interface interrupt mask (register UIR1, bit 1).	CKOUT:	Clock output.
ACTSEL:	Act mode select (register GR2, bit 6).	CODEC:	Coder/decoder, typically used for analog-to-digital conversions or digital-to-analog conversions.
ACTT:	Transmit activation (register GR1, bit 4).	CRATE[1:0]:	CKOUT rate control (register GR0, bits 2—1).
AFRST:	Adaptive filter reset (register CFR0, bit 1).	CRC:	Cyclic redundancy check.
AIB:	Alarm indication bit (register CFR1, bit 6).	DFR0:	Data flow control—U and S/T B-channels register.
ANSI:	American National Standards Institute.	DFR1:	Data flow control—D-channels and TDM bus register.
ASI:	Alternate space inversion.	DMR:	Receive EOC data or message indicator (register ECR2, bit 3).
AUTOACT:	Automatic activation control (register GR0, bit 6).	DMT:	Transmit EOC data or message indicator (register ECR0, bit 3).
AUTOCTL:	Auto control enable (register GR0, bit 3).	DPGS:	Digital pair gain system.
AUTOEOC:	Automatic EOC processor enable (register GR0, bit 4).	ECR0:	EOC state machine control—address register.
A[3:1]R:	Receive EOC address (register ECR2, bits 0—2).	ECR2:	EOC state machine status—address register.
A[3:1]T:	Transmit EOC address (register ECR0, bits 0—2).	ECR3:	EOC state machine status—information register.
BERR:	Block error on U-interface (register UIR0, bit 2).	EMINT:	Exit maintenance mode interrupt (register MIRO, bit 2).
BERRM:	Block error on U-interface interrupt mask (register UIR1, bit 2).	EMINTM:	Exit maintenance mode interrupt mask (register MIR1, bit 2).
CCRC:	Corrupt cyclic redundancy check (register ECR0, bit 7).	EOC:	Embedded operations channel.
CDM:	Charged-device model.	EOCSC:	EOC state change on U-interface (register UIR0, bit 0).
		EOCSCM:	EOC state change on U-interface mask (register UIR1, bit 0).
		ERC1:	EOC state machine control—information register.

Glossary (continued)

ESD:	Electrostatic discharge.	ILOSS:	Insertion loss test control (register CFR0, bit 0).
ETSI:	European Telecommunications Standards Institute.	$\overline{\text{ILOSS}}$:	Insertion loss test control.
FEBE:	Far-end block error (register CFR1, bit 5).	ISDN:	Integrated services digital network.
FSC[2:0]:	Frame strobe (FS) control, (register TDR0, bits 2—0).	ITU-T:	International Telecommunication Union-Telecommunication Sector.
FSP:	Frame strobe (FS) polarity (register TDR0, bit 3).	I[8:1]R:	Receive EOC information (register ECR3, bits 0—7).
FT:	Fixed/adaptive timing control (register GR2, bit 0).	I[8:1]T:	Transmit EOC information (register ERC1, bits 0—7).
FTE/TDMDI:	Fixed/adaptive timing mode select.	LON:	Line driver negative output for U-interface.
GIR0:	Global interrupt register.	LOP:	Line driver positive output for U-interface.
GND_A:	Analog ground.	LPBK:	U-interface analog loopback (register GR1, bit 0).
GND_O:	Crystal oscillator ground.	MCR0:	Q-channel bits register.
GR0:	Global device control—device configuration register.	MCR1:	S subchannel 1 register.
GR1:	Global device control—U-interface register.	MCR2:	S subchannel 2 register.
GR2:	Global device control—S/T-interface register.	MCR3:	S subchannel 3 register.
HBM:	Human-body model.	MCR4:	S subchannel 4 register.
HDLC:	High-level data link control.	MCR5:	S subchannel 5 register.
$\overline{\text{HIGHZ}}$:	High-impedance control.	MINT:	Maintenance interrupt (register GIR0, bit 2).
HN:	Hybrid negative input for U-interface.	MIR0:	Maintenance interrupt register.
HP:	Hybrid positive input for U-interface.	MIR1:	Maintenance interrupt mask register.
I4C:	INFO 4 change (register SIR0, bit 3).	MLT:	Metallic loop termination.
I4CM:	INFO 4 change mask (register SIR1, bit 3).	MULTIF:	Multiframe control (register GR0, bit 5).
I4I:	INFO 4 indicator (register CFR1, bit 7).	NEBE:	Near-end block error (register CFR1, bit 4).
ILINT:	Insertion loss interrupt (register MIR0, bit 1).	NTM:	NT test mode (register GR1, bit 3).
ILINTM:	Insertion loss interrupt mask (register MIR1, bit 1).	OOF:	Out of frame (register CFR1, bit 2).
		OPTOIN:	Optoisolator input.
		OUSC:	Other U-interface state change (register UIR0, bit 3).

Glossary (continued)

OUSCM:	Other U-interface state change mask (register UIR1, bit 3).	SAI[1:0]:	S/T-interface activity indicator control (register GR1, bits 6—7).
PS1:	Power status #1 (register GR1, bit 2).	SC1[4:1]:	S subchannel 1 (register MCR1, bits 0—3).
PS1E/TDMDO:	Power status #1, TDM clock.	SC2[4:1]:	S subchannel 2 (register MCR2, bits 0—3).
PS2:	Power status #2 (register GR1, bit 1).	SC3[4:1]:	S subchannel 3 (register MCR3, bits 0—3).
PS2E/TDMCLK:	Power status #2, TDM data out.	SC4[4:1]:	S subchannel 4 (register MCR4, bits 0—3).
QMINT:	Quiet mode interrupt (register MIRQ, bit 0).	SC5[4:1]:	S subchannel 5 (register MCR5, bits 0—3).
QMINTM:	Quiet mode interrupt mask (register MIR1, bit 0).	SCK:	Serial interface clock.
QSC:	Q-bits state change (register SIR0, bit 1).	SDI:	Serial interface data input.
QSCM:	Q-bits state change mask (register SIR1, bit 1).	SDINN:	Sigma-delta A/D negative input for U-interface.
Q[4:1]:	Q-channel bits (register MCR0, bits 0—3).	SDINP:	Sigma-delta A/D positive input for U-interface.
R25R:	Receive reserved bits (register CFR2, bit 2).	SDO:	Serial interface data output.
R25T:	Transmit reserved bit (register CFR0, bit 4).	SFECV:	S channel far-end code violation (register SIR0, bit 2).
R64T:	Transmit reserved bit (register CFR0, bit 5).	SFECVM:	S subchannel far-end code violation mask (register SIR1, bit 2).
RESET:	Reset.	SINT:	S/T transceiver interrupt (register GIRQ, bit 1).
RNR:	Receive negative rail for S/T-interface.	SIR0:	S/T-interface interrupt register.
RPR:	Receive positive rail for S/T-interface.	SIR1:	S/T-interface interrupt mask register.
RSFINT:	Receive superframe interrupt (register UIR0, bit 4).	SOM:	Start of multiframe (register SIR0, bit 0).
RSFINTM:	Receive superframe interrupt mask (register UIR1, bit 4).	SOMM:	Start of multiframe mask (register SIR1, bit 0).
R[16:15]R:	Receive reserved bits (register CFR2, bits 1—0).	SPWRUD:	S/T-interface powerdown control (register GR2, bit 1).
R[16:15]T:	Transmit reserved bits (register CFR0, bits 3—2).	SRESET:	S/T-interface reset (register GR2, bit 2).
R[64:54:44:34]R:	Receive reserved bits (register CFR2, bits 6—3).	STLED:	Status LED driver.
		STOA:	S/T-only activation (register GR2, bit 7).
		Superframe:	Eight U-frames grouped together.

Glossary (continued)

SXB1[1:0]:	S/T-interface transmit path source for B1 channel (register DFR0, bits 5—4).	TSFINTM:	Transmit superframe interrupt mask (register UIR1, bit 5).
SXB2[1:0]:	S/T-interface transmit path source for B2 channel (register DFR0, bits 7—6).	U frame:	An 18-bit synchronous word.
SXD:	S/T-interface transmit path source for D channel (register DFR1, bit 1).	U2BDLN:	Nontransparent 2B+D loopback control (register GR2, bit 4).
SXE:	S/T-interface D-channel echo bit control (register GR2, bit 3).	U2BDLT:	Transparent 2B+D loopback control (register ECR0, bit 6).
SYN8K/LBIND/FS:	Synchronous 8 kHz clock or loopback indicator, frame strobe.	UB1LP:	U-interface loopback of B1 channel control (register ECR0, bit 4).
TDM:	Time-division multiplexed.	UB2LP:	U-interface loopback of B2 channel control (register ECR0, bit 5).
TDMB1S:	TDM bus transmit control for B1 channel from S/T-interface (register DFR1, bit 2).	UINT:	U transceiver interrupt (register GIR0, bit 0).
TDMB1U:	TDM bus transmit control for B1 channel from U-interface (register DFR1, bit 5).	UIR0:	U-interface interrupt register.
TDMB2S:	TDM bus transmit control for B2 channel from S/T-interface (register DFR1, bit 3).	UIR1:	U-interface interrupt mask register.
TDMB2U:	TDM bus transmit control for B2 channel from U-interface (register DFR1, bit 6).	UOA:	U-interface only activation, (register CFR1, bit 3).
TDMDS:	TDM bus transmit control for D channel from S/T-interface (register DFR1, bit 4).	UXB1[1:0]:	U-interface transmit path source for B1 channel (register DFR0, bits 1—0).
TDMDU:	TDM bus transmit control for D channel from U-interface (register DFR1, bit 7).	UXB2[1:0]:	U-interface transmit path source for B2 channel (register DFR0, bits 3—2).
TDMEN:	TDM bus select (register GR2, bit 5).	UXD:	U-interface transmit path source for D channel (register DFR1, bit 0).
TDR0:	TDM bus timing control register.	V_{DDA}:	Analog power.
TNR:	Transmit negative rail for S/T-interface.	V_{DDO}:	Crystal oscillator power.
TPR:	Transmit positive rail for S/T-interface.	VRCM:	Common-mode voltage reference for U-interface circuits.
TSFINT:	Transmit superframe interrupt (register UIR0, bit 5).	VRN:	Negative voltage reference for U-interface circuits.
		VRP:	Positive voltage reference for U-interface circuits.
		X1:	Crystal #1.
		X2:	Crystal #2.
		XACT:	U transceiver active (register CFR1, bit 1).
		XPCY:	Transparency (register GR1, bit 5).

Standards Documentation

Telecommunication technical standards and reference documentation may be obtained from the following organizations:

ANSI (U.S.A.):

American National Standards Institute (ANSI)

11 West 42nd Street
New York, New York 10036

Tel: 212-642-4900
FAX: 212-302-1286

Lucent Technologies Publications:

Lucent Technologies Customer Information Center
(CIC)

Tel: 800-432-6600
FAX: 800-566-9568 (in U.S.A.)
FAX: 317-322-6484 (outside U.S.A.)

Bellcore (U.S.A.):

Bellcore Customer Service

8 Corporate Plaza
Piscataway, New Jersey 08854

Tel: 800-521-CORE (in U.S.A.)
Tel: 908-699-5800
FAX: 212-302-128

ITU-T:

International Telecommunication Union-
Telecommunication Sector

Place des Nations
CH 1211
Geneve 20, Switzerland

Tel: 41-22-730-5285
FAX: 41-22-730-5991

ETSI:

European Telecommunications Standards Institute

BP 152
F-06561 Valbonne Cedex, France

Tel: 33-92-94-42-00
FAX: 33-93-65-47-16

TTC (Japan):

TTC Standard Publishing Group of the
Telecommunications Technology Committee

2nd Floor, Hamamatsucho-Suzuki Building,
1 2-11, Hamamatsu-cho, Minato-ku, Tokyo

Tel: 81-3-3432-1551
FAX: 81-3-3432-1553

For additional information, contact your Microelectronics Group Account Manager or the following:

INTERNET: <http://www.lucent.com/micro>

E-MAIL: docmaster@micro.lucent.com

U.S.A.: Microelectronics Group, Lucent Technologies Inc., 555 Union Boulevard, Room 30L-15P-BA, Allentown, PA 18103
1-800-372-2447, FAX 610-712-4106 (In CANADA: **1-800-553-2448**, FAX 610-712-4106)

ASIA PACIFIC: Microelectronics Group, Lucent Technologies Singapore Pte. Ltd., 77 Science Park Drive, #03-18 Cintech III, Singapore 118256
Tel. (65) 778 8833, FAX (65) 777 7495

JAPAN: Microelectronics Group, Lucent Technologies Japan Ltd., 7-18, Higashi-Gotanda 2-chome, Shinagawa-ku, Tokyo 141, Japan
Tel. (81) 3 5421 1600, FAX (81) 3 5421 1700

EUROPE: Data Requests: MICROELECTRONICS GROUP DATALINE: **Tel. (44) 1189 324 299**, FAX (44) 1189 328 148
Technical Inquiries: GERMANY: **(49) 89 95086 0** (Munich), UNITED KINGDOM: **(44) 1344 865 900** (Bracknell),
FRANCE: **(33) 1 41 45 77 00** (Paris), SWEDEN: **(46) 8 600 7070** (Stockholm), FINLAND: **(358) 9 4354 2800** (Helsinki),
ITALY: **(39) 2 6601 1800** (Milan), SPAIN: **(34) 1 807 1441** (Madrid)

Lucent Technologies Inc. reserves the right to make changes to the product(s) or information contained herein without notice. No liability is assumed as a result of their use or application. No rights under any patent accompany the sale of any such product(s) or information.

