

Determining the Free-Running Frequency for QR Systems

Christophe BASSO
 ON Semiconductor
 14, rue Paul Mesplé – BP1112 – 31035 TOULOUSE Cedex 1 – France
 33 (0)5 34 61 11 54 e-mail: christophe.basso@onsemi.com



ON Semiconductor®

<http://onsemi.com>

APPLICATION NOTE

INTRODUCTION

A quasi-square wave Switch-Mode Power Supply offers many advantages such as a soft EMI signature and a constant efficiency over a broad output load range. However, by nature, a Quasi-Resonant (QR) supply exhibits a highly variable switching frequency which depends on the input / output operating conditions. This short application note details how to evaluate the switching frequency at a given operating point and thus gives the designer the necessary insight to dimension his system.

A Flyback Working in QR Mode

A Flyback working in QR mode is nothing else than a standard PWM-driven Flyback circuit to which a resonating tank has been added. Figure 1 shows the basic configuration of a converter that could be controlled through a dedicated circuit like ON Semiconductor NCP1205 or NCP1207.

On this circuit, the resonating tank is made of $L_p - C_p$, the primary inductance and the resonating capacitor. When the switch closes, the current builds-up in the primary inductance and the drain voltage is close to zero. At the switch opening, the leakage inductance together with C_p

dictate the rising slope of the drain voltage. When the leakage inductance is reset, the drain reaches a plateau made of V_{in} plus the reflected output voltage V_r . Finally, when the core is fully reset, a damped oscillation takes place on the drain and successive “valleys” (minimal) appear. If the reflected voltage is selected to be strong enough compared to V_{in} (ideal is when $V_r = V_{in}$), then the MOSFET can be re-started with a null drain-source voltage, minimizing all associated capacitive losses: this is called Zero-Voltage Switching (ZVS) operation. The “demag” winding offers an image of the core’s flux and helps to detect the reset event (when $I_{primary} = 0$). Unfortunately, ZVS can only be obtained if sufficient voltage is reflected on the drain. Figure 2 portrays a typical signal where the reflected voltage V_r is too low compared to V_{in} . When operating on universal mains up to 275 VAC, tradeoffs have to be made to ensure ZVS operation at high line but also to limit the MOSFET BV_{dss} to a reasonable value (a cost sensitive parameter...). An 800 V device, for instance, can be a good choice to allow QR operation over a large portion of the universal mains, for instance on a single output power supply.

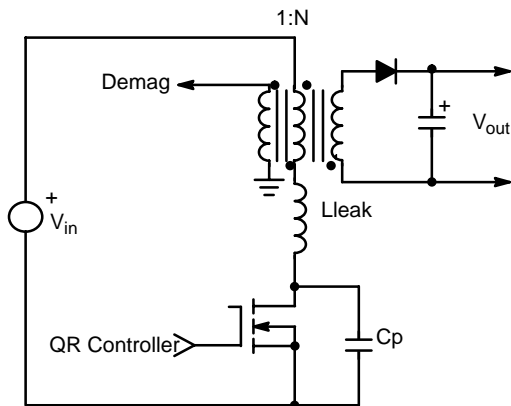

Figure 1. A QR Flyback Converter

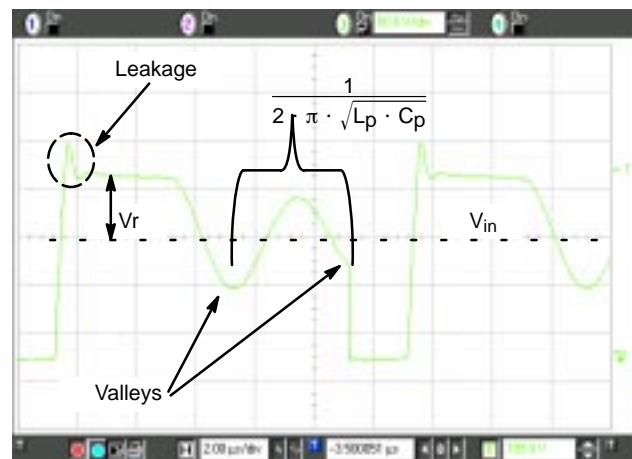

Figure 2. A Typical Drain-Source Signal of a QR Converter

A Succession of Events

To calculate the operating frequency of a QR converter, one needs to account for all the parasitic elements involved in the structure. For example, the leakage inductance plays a significant role in slowing down the drain-source signal. Neglecting it leads to a large error, especially if the resonating capacitor has been increased to reduce the dVds/dt and avoid a clamping network. To fully understand the time sequences, Figure 3 shows a QR converter truly operating in ZVS. Are present on this picture the drain-source signal Vds(t), the internal primary inductance

current Iprimary(t) and the driver waveshape to detail exactly when the MOSFET is re-activated.

To the light of this picture, it can be noticed that the primary current Iprimary(t) and Vds(t) being in quadrature, switching the MOSFET when Vds(t) equals zero also engenders Zero Current Switching (ZCS)! However, care must be taken to introduce the proper delay when core reset is detected. If this delay is too long or too short, then ZVS/ZCS can no longer be maintained and losses increase...

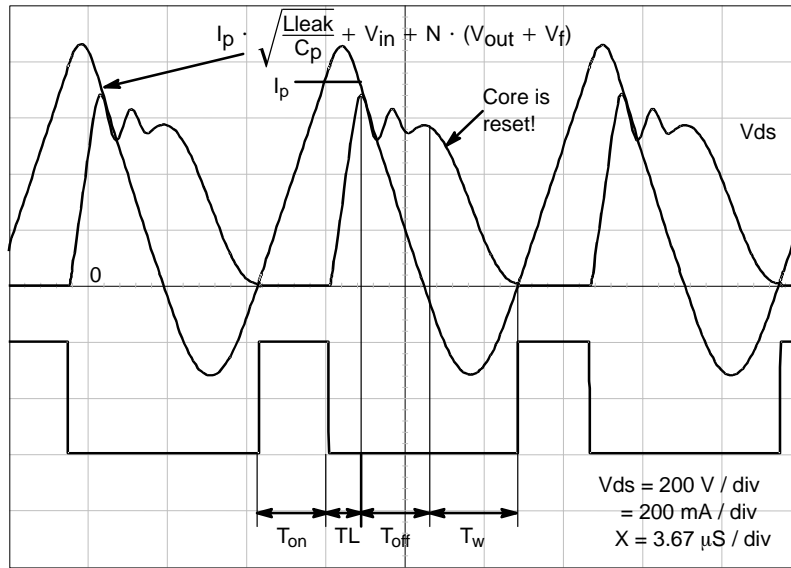

Figure 3. A Converter Truly Working in ZVS with a Smooth Vds Transition

Let's review, one by one, the events shown on Figure 3:

Ton:

The switch closes, forcing a voltage (Vin) across the primary inductance Lp. The current increases with a slope of:

$$\frac{V_{in}}{L_p} \quad (\text{eq. 1})$$

When Ip is reached, the controller dictates the opening of the switch. Therefore, Ton is equal to:

$$T_{on} = I_p \frac{L_p}{V_{in}} \quad (\text{eq. 2})$$

With: Lp the primary inductance, Vin the input voltage, Ip the peak current.

TLeak:

At the switch opening, the voltage cannot instantaneously increase and the perfidious leakage inductance delays the transfer of the primary current to the secondary. Vds rises with a slope imposed by the peak current present at the switch opening: Vds(t) slope is:

$$\frac{I_p}{C_p} \quad (\text{eq. 3})$$

if we neglect all other capacitance at the drain node. The peak voltage is given by the characteristic impedance of the resonating tank made by Lleak and Cp:

$$V_{ds \text{ max}} = I_p \cdot \sqrt{\frac{L_{leak}}{C_p}} + V_{in} + N \cdot (V_{out} + V_f) \quad (\text{eq. 4})$$

The secondary diode starts to conduct at the time Vds(t) reaches N x (Vout + Vf). Therefore, combining eq. 3 and eq. 4, we obtain the "rising" time:

$$T_L = \frac{[I_p \cdot \sqrt{\frac{L_{leak}}{C_p}} + V_{in} + N \cdot (V_{out} + V_f)] \cdot C_p}{I_p} \quad (\text{eq. 5})$$

With: Vout the output voltage, Vf the diode's forward drop, N the Np/Ns turn ratio, Lleak the leakage inductance, Cp the resonating capacitor.

T_{off}:

T_{off} represents the time needed to bring the peak current back to zero through the reflected voltage applied over L_p. Therefore, T_{off} can easily be derived:

$$T_{off} = I_p \cdot \frac{L_p}{N \cdot (V_{out} + V_f)} \quad (\text{eq. 6})$$

With: V_{out} the output voltage, V_f the diode's forward drop, N the N_p/N_s turn ratio

T_w:

Without entering into complex calculations, one can see that the valley occurs at half the natural ringing period imposed by L_p and C_p. T_w is thus defined by:

$$T_w = \pi \cdot \sqrt{L_p \cdot C_p} \quad (\text{eq. 7})$$

However, when complete calculations are undertaken, it shows that this result is only valid for lightly damped resonating tanks, which is often the case.

We now have everything needed to compute the switching frequency by summing up all these events and reversing the result:

$$F_{sw} = \frac{1}{I_p \cdot \frac{L_p}{V_{in}} + \frac{I_p \sqrt{\frac{L_{leak}}{C_p} + V_{in} + N \cdot (V_{out} + V_f)} \cdot C_p}{I_p} + I_p \cdot \frac{L_p}{N \cdot (V_{out} + V_f)} + \pi \cdot \sqrt{L_p \cdot C_p}} \quad (\text{eq. 8})$$

The unknown equation remains the peak current I_p. To obtain it, we need to start from the classical Flyback power transfer formula:

$$\frac{P_{out}}{n} = \frac{1}{2} \cdot L_p \cdot I_p^2 \cdot F_{sw} \quad (\text{eq. 9})$$

re-arranging it gives:

$$I_p = \sqrt{\frac{2 \cdot P_{out}}{\eta \cdot L_p \cdot F_{sw}}} \quad (\text{eq. 10})$$

Now, let's plug equation 10 into equation 8 to obtain a third order equation of I_p:

$$I_p^2 = \frac{2 \cdot P_{out}}{\eta \cdot L_p} \cdot \frac{L_p}{V_{in}} \cdot I_p + \frac{L_p}{N \cdot (V_{out} + V_f)} \cdot I_p + \pi \cdot \sqrt{L_p \cdot C_p} + (I_p \cdot \sqrt{\frac{L_{leak}}{C_p} + V_{in} + N \cdot (V_{out} + V_f)}) \frac{C_p}{I_p} \quad (\text{eq. 11})$$

This third order equation can be examined with a mathematical solver to obtain a rather complicated formula:

$$I_p = \frac{1}{6} \cdot \frac{[36 \cdot I_0 \cdot I_2^2 + 108 \cdot I_2 \cdot I_0 + 8 \cdot I_0^3 + 12 \cdot \sqrt{3} \cdot \sqrt{I_2^2 \cdot (-4 \cdot I_1^3 \cdot I_0 - I_1^2 \cdot I_2^2 + 18 \cdot I_1 \cdot I_0 \cdot I_2 + 27 \cdot I_2^2 + 4 \cdot I_2 \cdot I_0^2)}] + 12 \cdot I_1 \cdot I_0 + 4 \cdot I_0^2}{[36 \cdot I_1 \cdot I_2^2 + 108 \cdot I_2 \cdot I_0 + 8 \cdot I_0^3 + 12 \cdot \sqrt{3} \cdot \sqrt{I_2^2 \cdot (-4 \cdot I_1^3 \cdot I_0 - I_1^2 \cdot I_2^2 + 18 \cdot I_1 \cdot I_0 \cdot I_2 + 27 \cdot I_2^2 + 4 \cdot I_2 \cdot I_0^2)}]^{1/3}} + \frac{1 \cdot I_0}{3} \quad (\text{eq. 12})$$

with :

$$a = \sqrt{\frac{C_p}{L_p}} \quad I_0 = 2 \cdot \frac{P_{out}}{\eta} \cdot \frac{(V_{in} + V_r)}{V_{in} \cdot V_r}$$

$$b = \sqrt{\frac{L_{leak}}{L_p}} \quad I_1 = a \cdot (1 + b) \cdot \frac{V_{in} \cdot V_r}{V_{in} + V_r}$$

$$I_2 = \sqrt{a^2 \cdot (V_{in} \cdot V_r)}$$

Once I_p is known, the switching frequency can be computed via equation 8.

AND8089/D

To ease the designer work, we have entered this formula into an Excel spreadsheet available to download from ON Semiconductor web site (www.onsemi.com), NCP1205 or NCP1207 related sections. By entering the power supply parameters, you can quickly view the evolution of the switching frequency with the selected primary inductance L_p , the input voltage or select the inductance that brings the desired switching frequency in worse case conditions, e.g. highest output power and lowest input line. Below are some

typical curves given by the spreadsheet for a 30 W SMPS featuring the following component values:

$L_p = 1.4 \text{ mH}$
 $L_{\text{leak}} = 15 \text{ } \mu\text{H}$
 $V_{\text{out}} = 16.8 \text{ V}$
 $P_{\text{out}} = 30 \text{ W}$
 $N_p: N_s = 16.6$
 $C_p = 1.5 \text{ nF}$

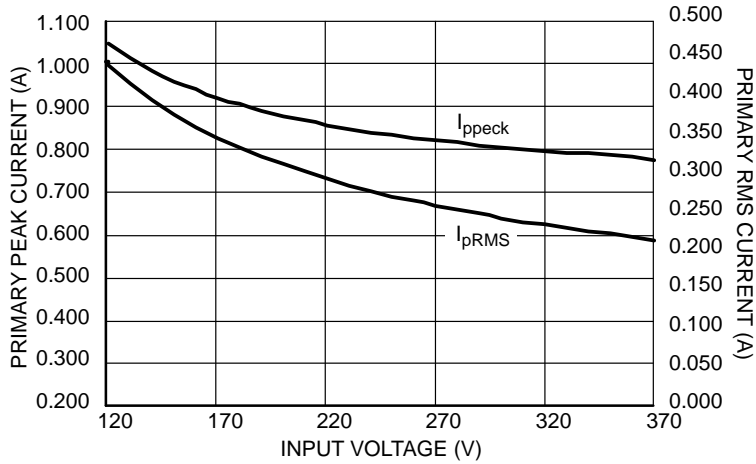

Figure 4. Peak Current Vs. Input Voltage
Primary Current Evolution with the Input Voltage

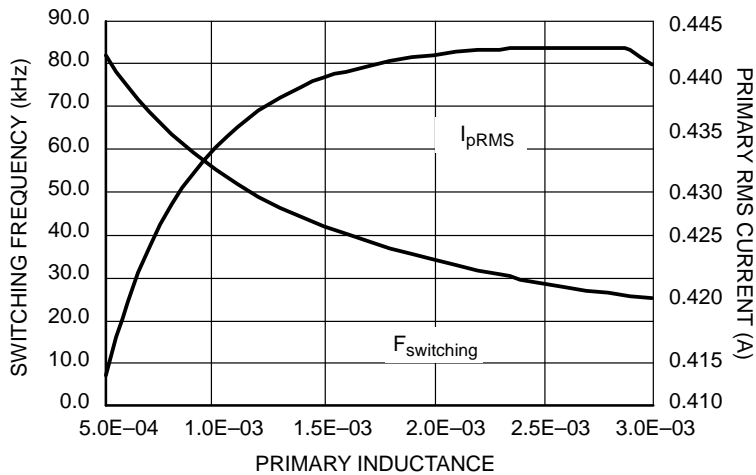

Figure 5. Free-Running Frequency vs. L_p .

(This graph lets you select the inductance value that will bring the desired frequency at low line)

AND8089/D

To check our calculations, the above 30 W prototype has been built using the NCP1205, a new QR controller featuring a soft frequency foldback with a Voltage Controller Oscillator. It is very important to ensure true

valley switching, e.g. starting right in the middle of the wave, or the above equations are no longer valid. The below graph compares the frequency variation with the input voltage measured on the board or calculated:

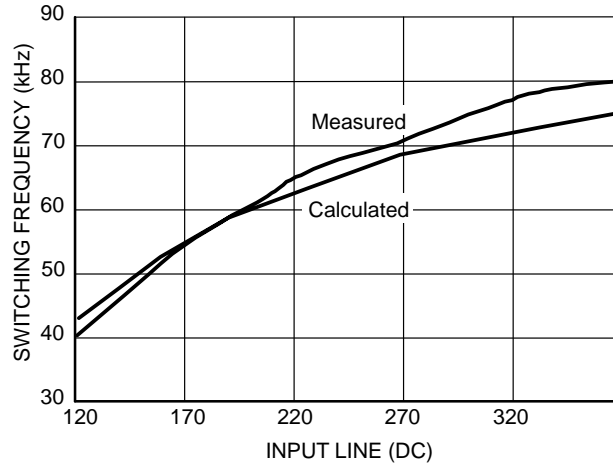

Figure 6. Switching Frequency vs. V_{in} @ $P_{out} = 30$ W

As one can see, both graphs are in good agreement and the high-line error is better than 10%, confirming the validity of our assumptions. The complete description of the board is the object of a dedicated application note, also available from the ON Semiconductor web site, NCP1205 and NCP1207 related sections.

Acknowledgements

The author wishes to thank his colleagues François Lhermite and Joël Turchi for fruitful discussions related to quasi-resonant converters.

Notes

Notes

ON Semiconductor and  are registered trademarks of Semiconductor Components Industries, LLC (SCILLC). SCILLC reserves the right to make changes without further notice to any products herein. SCILLC makes no warranty, representation or guarantee regarding the suitability of its products for any particular purpose, nor does SCILLC assume any liability arising out of the application or use of any product or circuit, and specifically disclaims any and all liability, including without limitation special, consequential or incidental damages. "Typical" parameters which may be provided in SCILLC data sheets and/or specifications can and do vary in different applications and actual performance may vary over time. All operating parameters, including "Typicals" must be validated for each customer application by customer's technical experts. SCILLC does not convey any license under its patent rights nor the rights of others. SCILLC products are not designed, intended, or authorized for use as components in systems intended for surgical implant into the body, or other applications intended to support or sustain life, or for any other application in which the failure of the SCILLC product could create a situation where personal injury or death may occur. Should Buyer purchase or use SCILLC products for any such unintended or unauthorized application, Buyer shall indemnify and hold SCILLC and its officers, employees, subsidiaries, affiliates, and distributors harmless against all claims, costs, damages, and expenses, and reasonable attorney fees arising out of, directly or indirectly, any claim of personal injury or death associated with such unintended or unauthorized use, even if such claim alleges that SCILLC was negligent regarding the design or manufacture of the part. SCILLC is an Equal Opportunity/Affirmative Action Employer.

PUBLICATION ORDERING INFORMATION

Literature Fulfillment:

Literature Distribution Center for ON Semiconductor
P.O. Box 5163, Denver, Colorado 80217 USA
Phone: 303-675-2175 or 800-344-3860 Toll Free USA/Canada
Fax: 303-675-2176 or 800-344-3867 Toll Free USA/Canada
Email: ONlit@hibbertco.com

N. American Technical Support: 800-282-9855 Toll Free USA/Canada

JAPAN: ON Semiconductor, Japan Customer Focus Center
2-9-1 Kamimeguro, Meguro-ku, Tokyo, Japan 153-0051
Phone: 81-3-5773-3850
Email: r14525@onsemi.com

ON Semiconductor Website: <http://onsemi.com>

For additional information, please contact your local Sales Representative.