

**300mA HIGH SPEED, EXTREMELY LOW NOISE CMOS LDO REGULATOR AP2128**

**General Description**

The AP2128 Series are positive voltage regulator ICs fabricated by CMOS process. The AP2128 provides two kinds of output voltage operation modes for setting the output voltage. Fixed output voltage mode senses the output voltage on  $V_{OUT}$ , adjustable output voltage mode needs two resistors as a voltage divider

The AP2128 Series have features of low dropout voltage, low noise, high output voltage accuracy, and low current consumption which make them ideal for use in various battery-powered devices.

AP2128 has 1.0V, 1.2V, 3.3V fixed voltage version and 0.8V to 4.5V adjustable voltage version.

AP2128 series are available in SOT-23-5 Package.

**Features**

- Wide Operating Voltage: 2.5V to 6V
- Low Dropout Voltage (3.3V only): 170mV@300mA
- High Output Voltage Accuracy:  $\pm 2\%$
- High Ripple Rejection: 65dB@ f=1kHz, 45dB@ f=10kHz
- Low Standby Current: 0.1 $\mu$ A
- Low Quiescent Current: 60 $\mu$ A Typical
- Low Output Noise: 60 $\mu$ Vrms
- Short Current Limit: 50mA
- Over Temperature Protection
- Compatible with Low ESR Ceramic Capacitor: 1 $\mu$ F for  $C_{IN}$  and  $C_{OUT}$
- Excellent Line/Load Regulation
- Soft Start Time: 50 $\mu$ s
- Auto Discharge Resistance:  $R_{DS(ON)}=60\Omega$

**Applications**

- Datacom
- Notebook Computers
- Mother Board

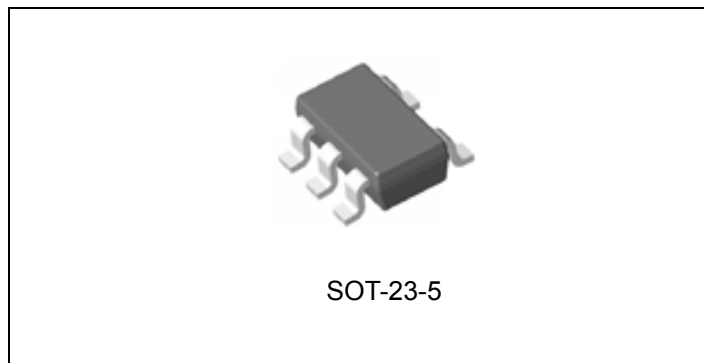

Figure 1. Package Type of AP2128

**Pin Configuration**

K Package  
(SOT-23-5)

www.DataSheet4U.com

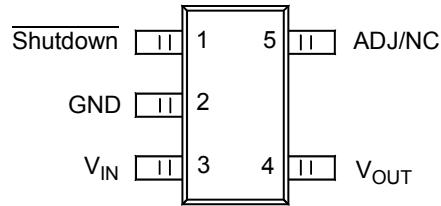
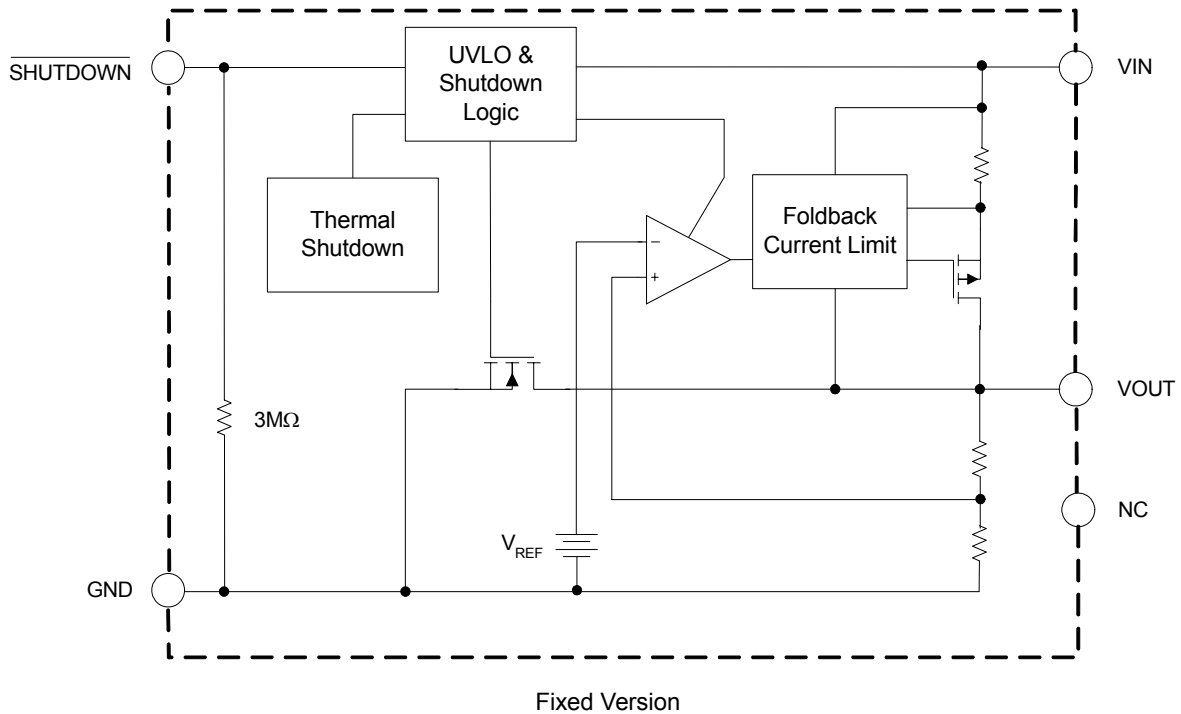

Figure 2. Pin Configuration of AP2128 (Top View)

**Functional Block Diagram**



**Functional Block Diagram (Continued)**

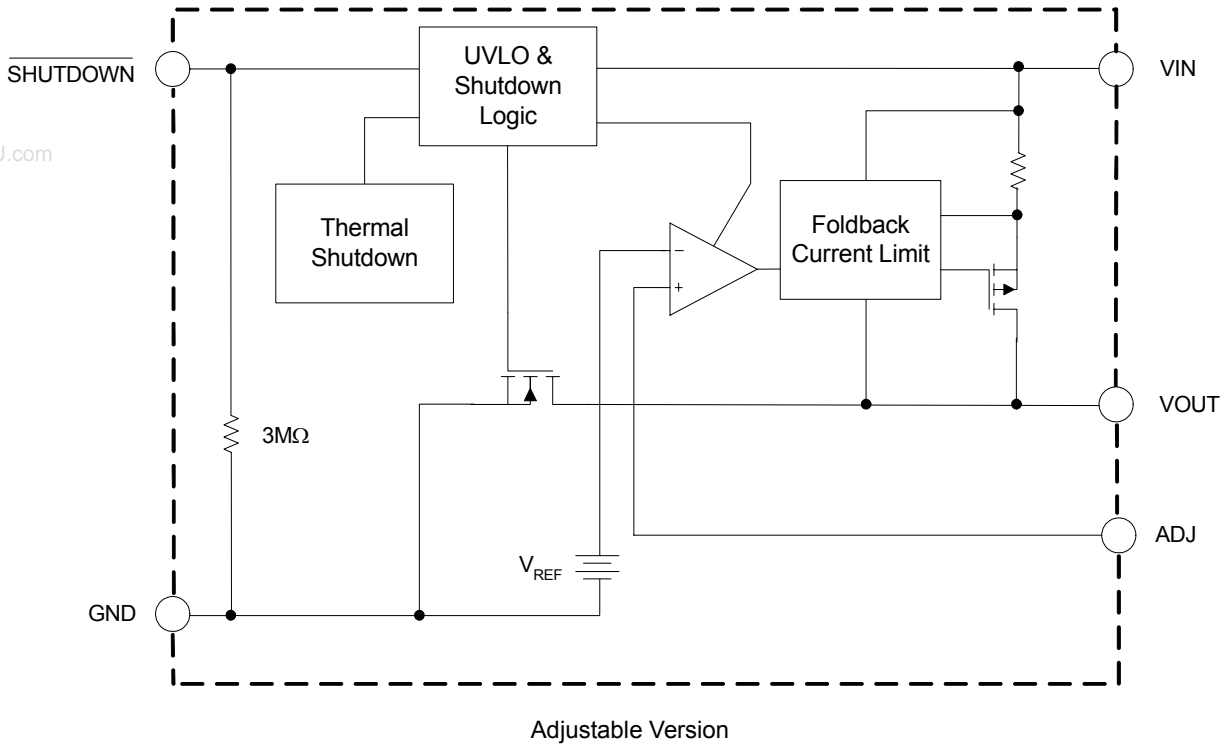
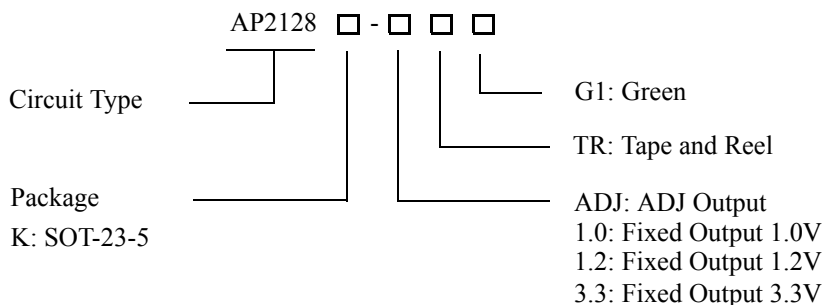

Figure 3. Functional Block Diagram of AP2128



**300mA HIGH SPEED, EXTREMELY LOW NOISE CMOS LDO REGULATOR AP2128**

**Ordering Information**



www.DataSheet4U.com

Product	Package	Temperature Range	Part Number	Marking ID	Packing Type
			Green	Green	
AP2128	SOT-23-5	-40 to 85°C	AP2128K- ADJTRG1	FAD	Tape & Reel
			AP2128K-1.0TRG1	FAJ	Tape & Reel
			AP2128K-1.2TRG1	FAK	Tape & Reel
			AP2128K-3.3TRG1	FAL	Tape & Reel

BCD Semiconductor's products, as designated with "G1" suffix in the part number, are RoHS compliant and Green.

**300mA HIGH SPEED, EXTREMELY LOW NOISE CMOS LDO REGULATOR****AP2128****Absolute Maximum Ratings (Note 1)**

Parameter	Symbol	Value	Unit
Input Voltage	$V_{IN}$	6.5	V
Shutdown Input Voltage	$V_{CE}$	-0.3 to $V_{IN}+0.3$	V
Output Current	$I_{OUT}$	450	mA
Junction Temperature	$T_J$	150	°C
Storage Temperature Range	$T_{STG}$	-65 to 150	°C
Lead Temperature (Soldering, 10sec)	$T_{LEAD}$	260	°C
Thermal Resistance	$R_{\theta JA}$	250	°C/W
ESD (Human Body Model)	ESD	6000	V
ESD (Machine Model)	ESD	300	V

Note 1: Stresses greater than those listed under "Absolute Maximum Ratings" may cause permanent damage to the device. These are stress ratings only, and functional operation of the device at these or any other conditions beyond those indicated under "Recommended Operating Conditions" is not implied. Exposure to "Absolute Maximum Ratings" for extended periods may affect device reliability.

**Recommended Operating Conditions**

Parameter	Symbol	Min	Max	Unit
Input Voltage	$V_{IN}$	2.5	6	V
Operating Junction Temperature Range	$T_J$	-40	85	°C



**300mA HIGH SPEED, EXTREMELY LOW NOISE CMOS LDO REGULATOR AP2128**

**Electrical Characteristics**

(AP2128-ADJ,  $V_{IN} \text{ min}=2.5\text{V}$ ,  $C_{IN}=1\mu\text{F}$ ,  $C_{OUT}=1\mu\text{F}$ , Bold typeface applies over  $-40^{\circ}\text{C}\leq T_J\leq 85^{\circ}\text{C}$ , unless otherwise specified.)

Parameter	Symbol	Conditions	Min	Typ	Max	Unit
Reference Voltage	$V_{REF}$	$V_{IN}=2.5\text{V}$ $1\text{mA}\leq I_{OUT}\leq 300\text{mA}$	0.748	0.8	0.816	V
Input Voltage	$V_{IN}$		2.5		6	V
Maximum Output Current	$I_{OUT(MAX)}$			450		mA
Load Regulation	$\frac{\Delta V_{OUT}}{(\Delta I_{OUT}\cdot V_{OUT})}$	$V_{IN}-V_{OUT}=1\text{V}$ , $1\text{mA}\leq I_{OUT}\leq 300\text{mA}$			0.6	%/A
Line Regulation	$\frac{\Delta V_{OUT}}{(\Delta V_{IN}\cdot V_{OUT})}$	$V_{OUT}+0.5\text{V}\leq V_{IN}\leq 6\text{V}$ $I_{OUT}=30\text{mA}$			0.06	%/V
Quiescent Current	$I_Q$	$V_{IN}=V_{OUT}+1\text{V}$ , $I_{OUT}=0\text{mA}$		60	90	$\mu\text{A}$
Standby Current	$I_{STD}$	$V_{IN}=V_{OUT}+1\text{V}$ , $V_{SHUTDOWN}$ in off mode		0.1	1.0	$\mu\text{A}$
Power Supply Rejection Ratio	PSRR	Ripple 1Vp-p $V_{IN}=V_{OUT}+1\text{V}$	$f=100\text{Hz}$		65	dB
			$f=1\text{KHz}$		65	dB
			$f=10\text{KHz}$		45	dB
Output Voltage Temperature Coefficient	$\frac{(\Delta V_{OUT}/V_{OUT})}{\Delta T}$	$I_{OUT}=30\text{mA}$ , $-40^{\circ}\text{C}\leq T_J\leq 85^{\circ}\text{C}$		$\pm 100$		ppm/ $^{\circ}\text{C}$
Output Current Limit	$I_{LIMIT}$			400		mA
Short Current Limit	$I_{SHORT}$	$V_{OUT}=0\text{V}$		50		mA
Soft Start Time	$t_{UP}$			50		$\mu\text{s}$
RMS Output Noise	$V_{NOISE}$	$T_A=25^{\circ}\text{C}$ , $10\text{Hz}\leq f\leq 100\text{kHz}$		60		$\mu\text{V}_{rms}$
Shutdown "High" Voltage		Shutdown input voltage "High"	1.5		6	V
Shutdown "Low" Voltage		Shutdown input voltage "Low"	0		0.4	V
$V_{OUT}$ Discharge MOSFET $R_{DS(ON)}$		Shutdown input voltage "Low"		60		$\Omega$
Shutdown Pull Down Resistance				3		$\text{M}\Omega$
Thermal Shutdown				165		$^{\circ}\text{C}$
Thermal Shutdown Hysteresis				30		$^{\circ}\text{C}$



**300mA HIGH SPEED, EXTREMELY LOW NOISE CMOS LDO REGULATOR AP2128**

**Electrical Characteristics (Continued)**

(AP2128-1.0V/1.2V, VIN min. =2.5V, AP2128-3.3V,

CIN=1μF, COUT=1μF, Bold typeface applies over -40°C≤Tj≤85°C, unless otherwise specified.)

Parameter	Symbol	Conditions	Min	Typ	Max	Unit	
Output Voltage	V <sub>OUT</sub>	V <sub>IN</sub> =V <sub>OUT</sub> +1V 1mA≤I <sub>OUT</sub> ≤300mA	98%* V <sub>OUT</sub>		102%* V <sub>OUT</sub>	V	
Input Voltage	V <sub>IN</sub>		2.5		6	V	
Maximum Output Current	I <sub>OUT(MAX)</sub>			450		mA	
Load Regulation	$\frac{\Delta V_{OUT}}{(\Delta I_{OUT} * V_{OUT})}$	V <sub>IN</sub> -V <sub>OUT</sub> =1V, 1mA≤I <sub>OUT</sub> ≤300mA			0.6	%/A	
Line Regulation	$\frac{\Delta V_{OUT}}{(\Delta V_{IN} * V_{OUT})}$	V <sub>OUT</sub> +0.5V≤V <sub>IN</sub> ≤6V I <sub>OUT</sub> =30mA			0.06	%/V	
Dropout Voltage	V <sub>DROP</sub>	V <sub>OUT</sub> =1.0V, I <sub>OUT</sub> =300mA		1400	1500	mV	
		V <sub>OUT</sub> =1.2V, I <sub>OUT</sub> =300mA		1200	1300		
		V <sub>OUT</sub> =3.3V, I <sub>OUT</sub> =300mA		170	300		
Quiescent Current	I <sub>Q</sub>	V <sub>IN</sub> =V <sub>OUT</sub> +1V, I <sub>OUT</sub> =0mA		60	90	μA	
Standby Current	I <sub>STD</sub>	V <sub>IN</sub> =V <sub>OUT</sub> +1V, V <sub>SHUTDOWN</sub> in off mode		0.1	1.0	μA	
Power Supply Rejection Ratio	PSRR	Ripple 1Vp-p V <sub>IN</sub> =V <sub>OUT</sub> +1V	f=100Hz		65		dB
			f=1KHz		65		dB
			f=10KHz		45		dB
Output Voltage Temperature Coefficient	$\frac{(\Delta V_{OUT}/V_{OUT})}{\Delta T}$	I <sub>OUT</sub> =30mA, -40°C≤T <sub>j</sub> ≤85°C		±100		ppm/°C	
Output Current Limit	I <sub>LIMIT</sub>	V <sub>IN</sub> -V <sub>OUT</sub> =1V, V <sub>OUT</sub> =0.98*V <sub>OUT</sub>		400		mA	
Short Current Limit	I <sub>SHORT</sub>	V <sub>OUT</sub> =0V		50		mA	
Soft Start Time	t <sub>UP</sub>			50		μs	
RMS Output Noise	V <sub>NOISE</sub>	T <sub>A</sub> =25°C, 10Hz≤f≤100kHz		60		μVrms	
Shutdown "High" Voltage		Shutdown input voltage "High"	1.5		6	V	
Shutdown "Low" Voltage		Shutdown input voltage "Low"	0		0.4	V	
V <sub>OUT</sub> Discharge MOSFET R <sub>DS(ON)</sub>		Shutdown input voltage "Low"		60		Ω	
Shutdown Pull Down Resistance				3		MΩ	
Thermal Shutdown				165		°C	
Thermal Shutdown Hysteresis				30		°C	



**300mA HIGH SPEED, EXTREMELY LOW NOISE CMOS LDO REGULATOR AP2128**

**Typical Performance Characteristics**

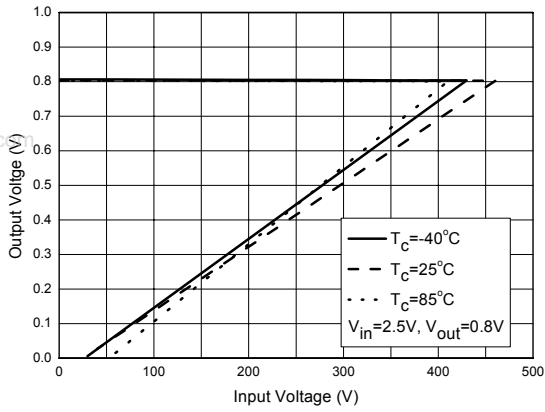

Figure 4. Output Voltage vs. Output Current

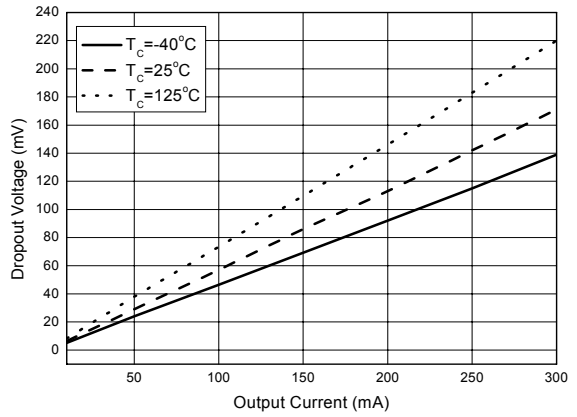

Figure 5. Dropout Voltage vs. Output Current,  $V_{OUT}=3.3V$

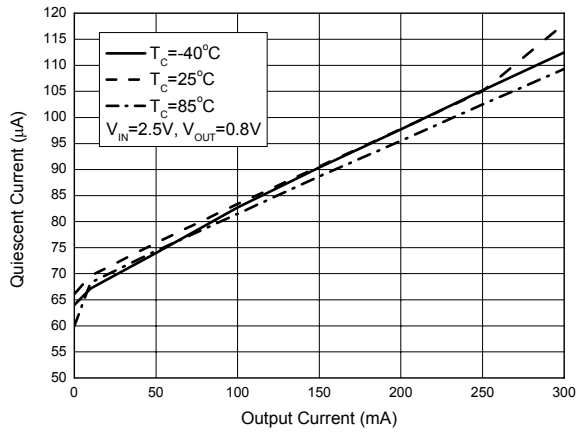

Figure 6. Quiescent Current vs. Output Current

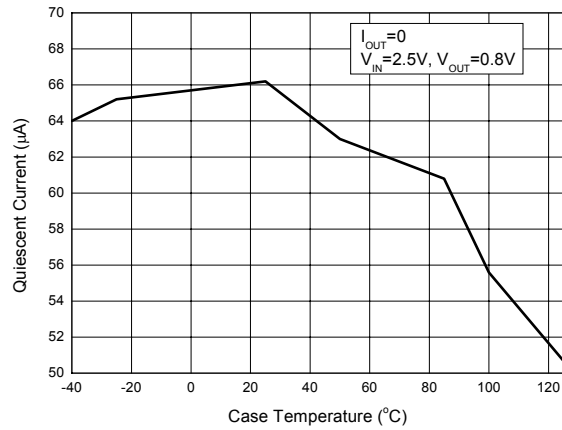

Figure 7. Quiescent Current vs. Case Temperature





**300mA HIGH SPEED, EXTREMELY LOW NOISE CMOS LDO REGULATOR AP2128**

**Typical Performance Characteristics (Continued)**

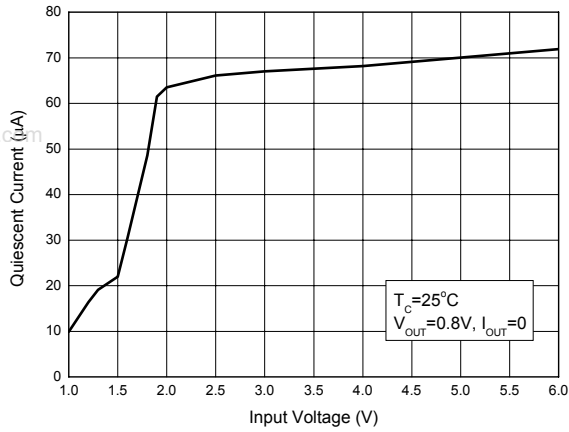

Figure 8. Quiescent Current vs. Input Voltage

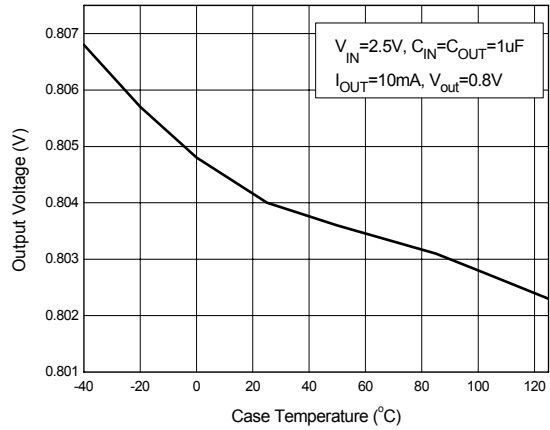

Figure 9. Output Voltage vs. Case Temperature

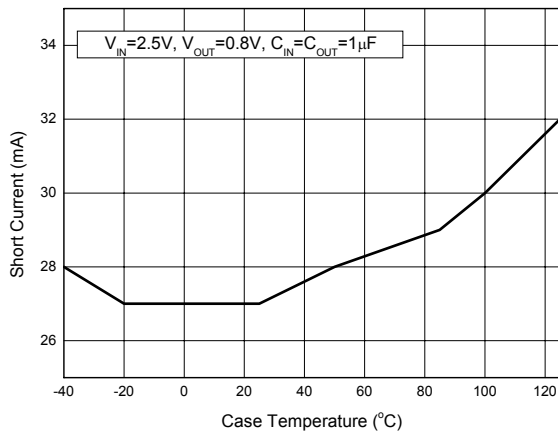

Figure 10. Short Current vs. Case Temperature

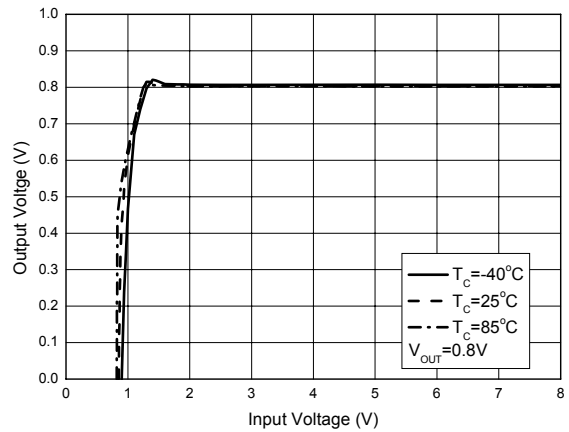

Figure 11. Output Voltage vs. Input Voltage (I<sub>OUT</sub>=0mA)



**300mA HIGH SPEED, EXTREMELY LOW NOISE CMOS LDO REGULATOR AP2128**

**Typical Performance Characteristics (Continued)**

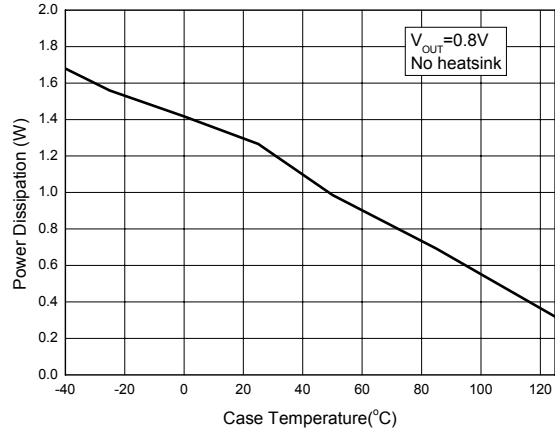
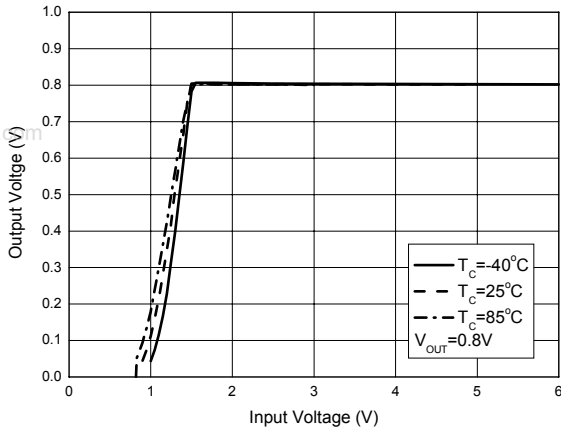

Figure 12. Output Voltage vs. Input Voltage ( $I_{OUT}=300mA$ )

Figure 13. Power Dissipation vs. Case Temperature

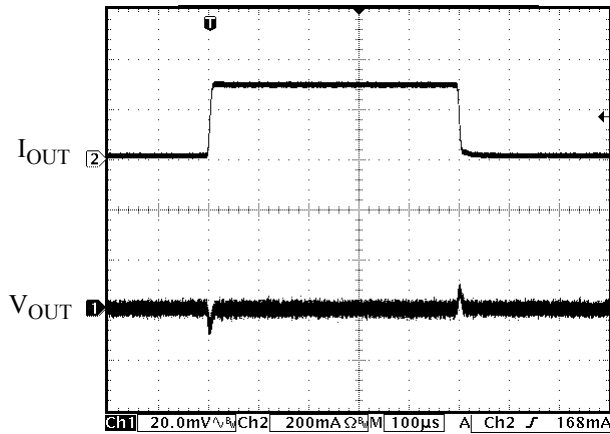

Figure 14. Load Transient  
(Conditions:  $C_{IN}=C_{OUT}=1\mu F$ ,  $V_{IN}=2.5V$ ,  $V_{OUT}=0.8V$ )

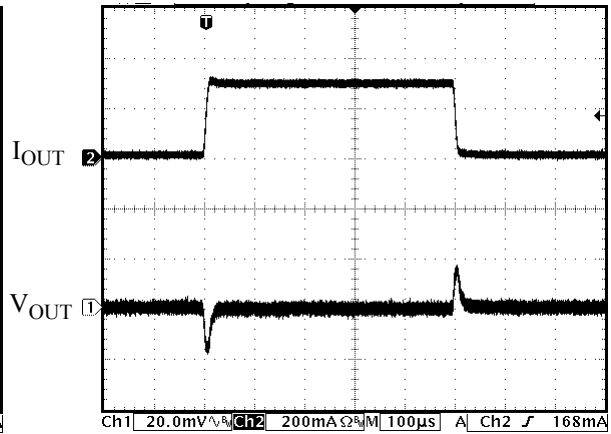

Figure 15. Load Transient  
(Conditions:  $C_{IN}=C_{OUT}=1\mu F$ ,  $V_{IN}=4.4V$ ,  $V_{OUT}=3.3V$ )



**300mA HIGH SPEED, EXTREMELY LOW NOISE CMOS LDO REGULATOR AP2128**

**Typical Performance Characteristics (Continued)**

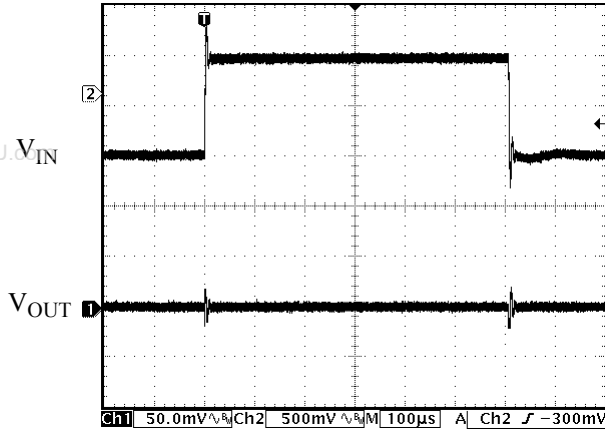

Figure 16. Line Transient

(Conditions:  $I_{OUT}=30mA$ ,  $C_{IN}=C_{OUT}=1\mu F$ ,  
 $V_{IN}=2.5$  to  $3.5V$ ,  $V_{OUT}=0.8V$ )

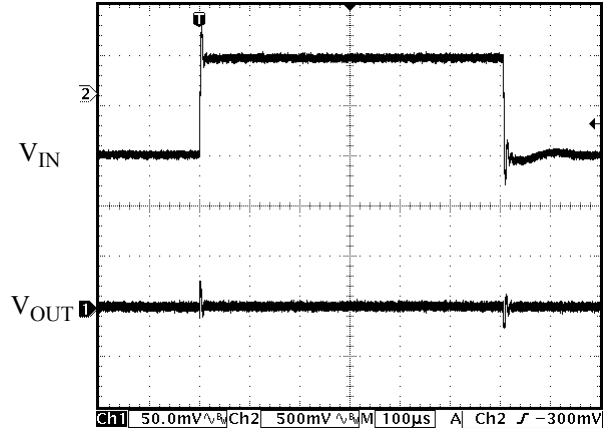

Figure 17. Line Transient

(Conditions:  $I_{OUT}=30mA$ ,  $C_{IN}=C_{OUT}=1\mu F$ ,  
 $V_{IN}=4$  to  $5V$ ,  $V_{OUT}=3.3V$ )

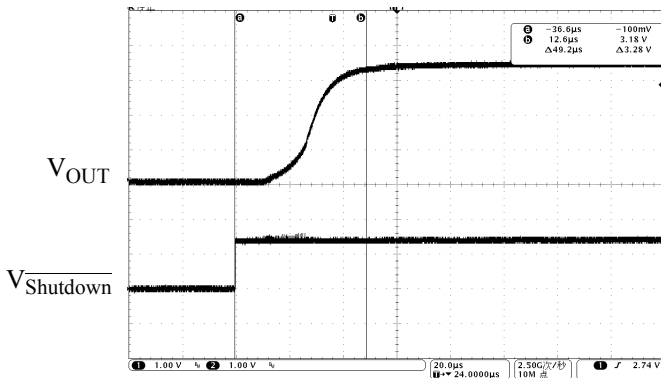

Figure 18. Soft Start Time

(Conditions:  $I_{OUT}=0mA$ ,  $C_{IN}=C_{OUT}=1\mu F$ ,  
 $V_{Shutdown}=0$  to  $2V$ ,  $V_{OUT}=3.3V$ )

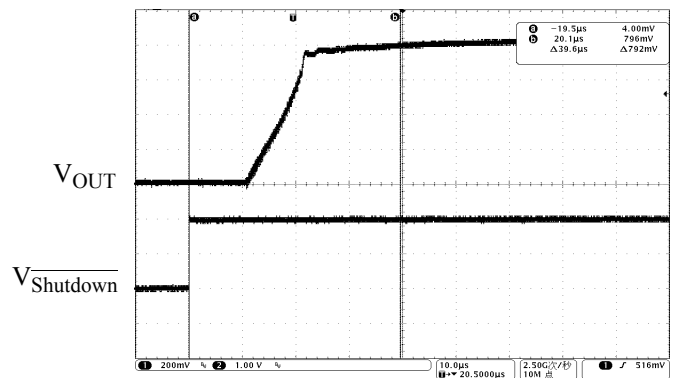

Figure 19. Soft Start Time

(Conditions:  $I_{OUT}=0mA$ ,  $C_{IN}=C_{OUT}=1\mu F$ ,  
 $V_{Shutdown}=0$  to  $2V$ ,  $V_{OUT}=0.8V$ )



**Typical Performance Characteristics (Continued)**

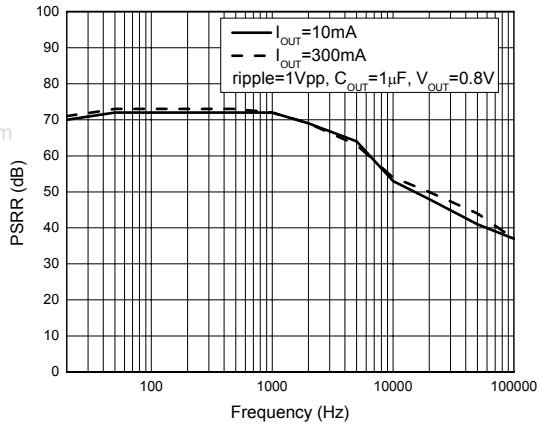

Figure 20. PSRR vs. Frequency

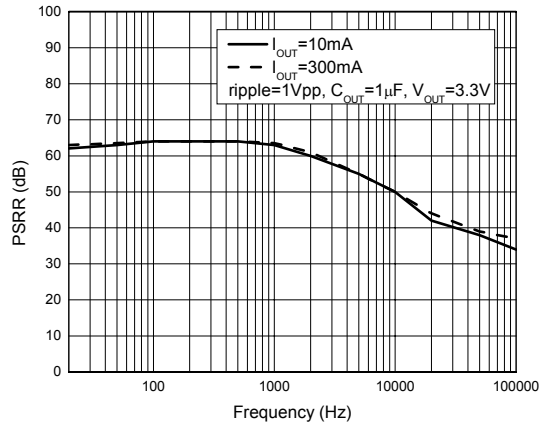
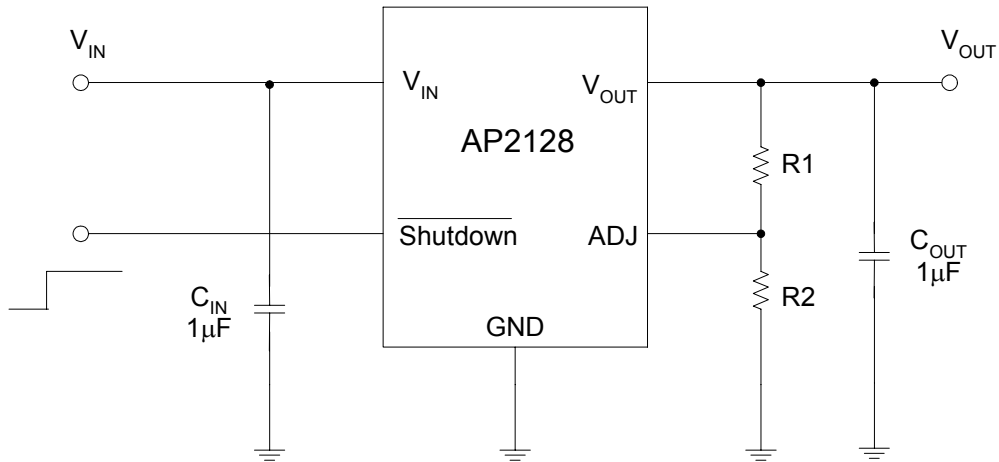
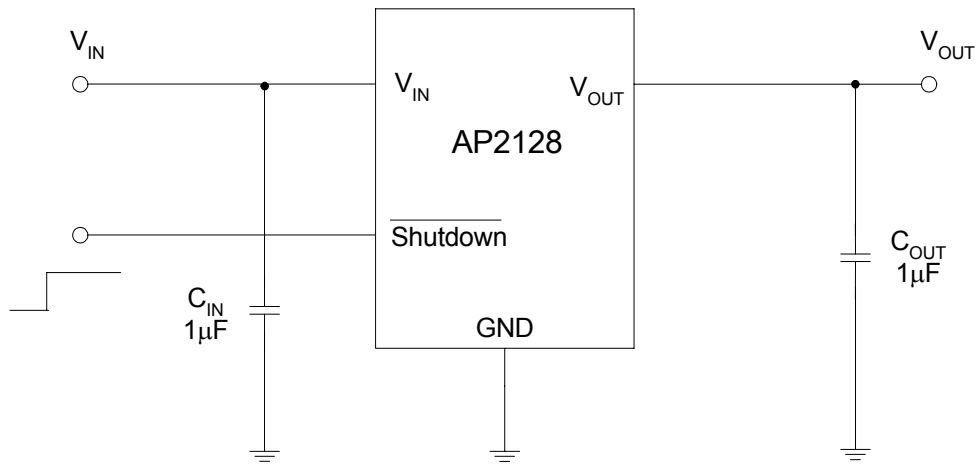

Figure 21. PSRR vs. Frequency

**Typical Application**



$$V_{OUT} = 0.8 * (1 + R1/R2) V$$



$$V_{OUT} = 1.0, 1.2, 3.3V$$

Figure 22. Typical Application of AP2128



Mechanical Dimensions

SOT-23-5

Unit: mm(inch)

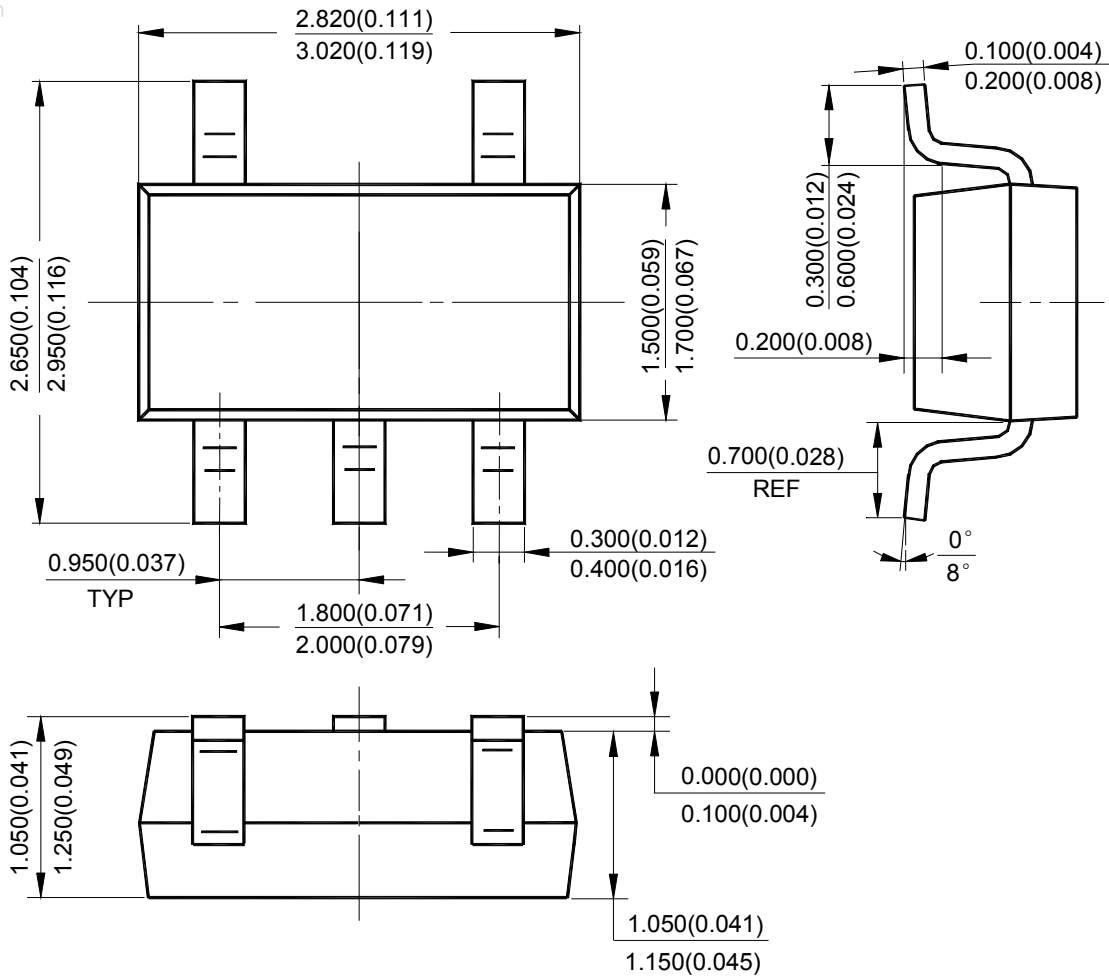



## BCD Semiconductor Manufacturing Limited

<http://www.bcdsemi.com>

### IMPORTANT NOTICE

BCD Semiconductor Manufacturing Limited reserves the right to make changes without further notice to any products or specifications herein. BCD Semiconductor Manufacturing Limited does not assume any responsibility for use of any its products for any particular purpose, nor does BCD Semiconductor Manufacturing Limited assume any liability arising out of the application or use of any its products or circuits. BCD Semiconductor Manufacturing Limited does not convey any license under its patent rights or other rights nor the rights of others.

---

#### MAIN SITE

##### - Headquarters

##### BCD Semiconductor Manufacturing Limited

No. 1600, Zi Xing Road, Shanghai Zizhu Science-based Industrial Park, 200241, China  
Tel: +86-21-24162266, Fax: +86-21-24162277

##### - Wafer Fab

##### Shanghai SIM-BCD Semiconductor Manufacturing Co., Ltd.

800 Yi Shan Road, Shanghai 200233, China  
Tel: +86-21-6485 1491, Fax: +86-21-5450 0008

#### REGIONAL SALES OFFICE

##### Shenzhen Office

Shanghai SIM-BCD Semiconductor Manufacturing Co., Ltd., Shenzhen Office  
Room E, 5F, Noble Center, No.1006, 3rd Fuzhong Road, Futian District, Shenzhen,  
518026, China  
Tel: +86-755-8826 7951  
Fax: +86-755-8826 7865

##### Taiwan Office

BCD Semiconductor (Taiwan) Company Limited  
4F, 298-1, Rui Guang Road, Nei-Hu District, Taipei,  
Taiwan  
Tel: +886-2-2656 2808  
Fax: +886-2-2656 2806

##### USA Office

BCD Semiconductor Corp.  
30920 Huntwood Ave. Hayward,  
CA 94544, USA  
Tel : +1-510-324-2988  
Fax: +1-510-324-2788