

# 2SK1206, 2SK1225

## SILICON N-CHANNEL MOS FET

### HIGH SPEED POWER SWITCHING

#### ■ FEATURES

- Low On-Resistance
- High Speed Switching
- Low Drive Current
- No Secondary Breakdown
- Suitable for Switching Regulator, DC-DC Converter and Motor Driver

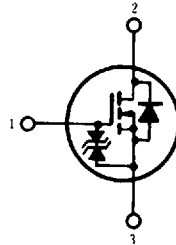

1. Gate  
2. Drain  
3. Source

(Dimensions in mm)

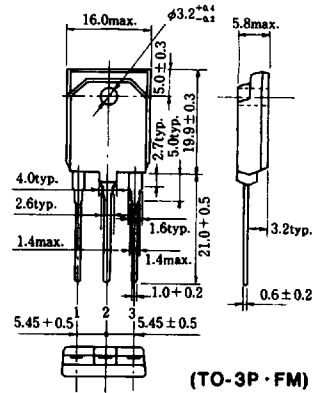

(TO-3P · FM)

#### ■ ABSOLUTE MAXIMUM RATINGS ( $T_a=25^\circ\text{C}$ )

Item	Symbol	2SK1225	2SK1206	Unit
Drain-Source Voltage	$V_{DS}$	450	500	V
Gate-Source Voltage	$V_{GS}$	±20		V
Drain Current	$I_D$	12		A
Drain Peak Current	$I_{D(pulse)}$ *	48		A
Body-Drain Diode Reverse Drain Current	$I_{DR}$	12		A
Channel Dissipation	$P_{ch}$ *	60		W
Channel Temperature	$T_{ch}$	150		°C
Storage Temperature	$T_{stg}$	-55 ~ +150		°C

\* $PW \leq 10\mu\text{s}$ , duty cycle  $\leq 1\%$   
\*\*Value at  $T_c=25^\circ\text{C}$

#### POWER VS. TEMPERATURE DERATING

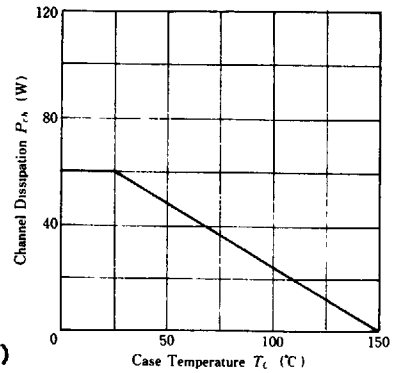

HITACHI/(OPTOELECTRONICS)

#### ■ ELECTRICAL CHARACTERISTICS ( $T_a=25^\circ\text{C}$ )

Item	Symbol	Test Condition	min.	typ.	max.	Unit
Drain-Source Breakdown Voltage	2SK1225	$I_D=10\text{mA}$ , $V_{GS}=0$	450	—	—	V
	2SK1206		500	—	—	
Gate-Source Breakdown Voltage	$V_{BR/GSS}$	$I_G=\pm 100\mu\text{A}$ , $V_{DS}=0$	±20	—	—	V
Gate-Source Leak Current	$I_{GSS}$	$V_{GS}=\pm 16\text{V}$ , $V_{DS}=0$	—	—	±10	μA
Zero Gate Voltage Drain Current	2SK1225	$V_{DS}=360\text{V}$ , $V_{GS}=0$	—	—	250	μA
	2SK1206		$V_{DS}=400\text{V}$ , $V_{GS}=0$	—	—	
Gate-Source Cutoff Voltage	$V_{GS(off)}$	$I_D=1\text{mA}$ , $V_{DS}=10\text{V}$	2.0	—	4.0	V
Static Drain-Source On State Resistance	2SK1225	$I_D=6\text{A}$ , $V_{GS}=10\text{V}^*$	—	0.4	0.55	Ω
	2SK1206		—	0.45	0.60	
Forward Transfer Admittance	$ y_{fs} $	$I_D=6\text{A}$ , $V_{DS}=10\text{V}^*$	6	10	—	S
Input Capacitance	$C_{iss}$	$V_{DS}=10\text{V}$ , $V_{GS}=0$ , $f=1\text{MHz}$	—	2050	—	pF
Output Capacitance	$C_{oss}$		—	720	—	pF
Reverse Transfer Capacitance	$C_{rss}$		—	80	—	pF
Turn-on Delay Time	$t_{d(on)}$	$I_D=6\text{A}$ , $V_{GS}=10\text{V}$ , $R_L=5\Omega$	—	25	—	ns
Rise Time	$t_r$		—	85	—	ns
Turn-off Delay Time	$t_{d(off)}$		—	145	—	ns
Fall Time	$t_f$		—	85	—	ns
Body-Drain Diode Forward Voltage	$V_{DF}$	$I_F=12\text{A}$ , $V_{GS}=0$	—	1.0	—	V
Body-Drain Diode Reverse Recovery Time	$t_{rr}$	$I_F=12\text{A}$ , $V_{GS}=0$ , $di_F/dt=100\text{A}/\mu\text{s}$	—	450	—	ns

\*Pulse Test

**MAXIMUM SAFE OPERATION AREA**

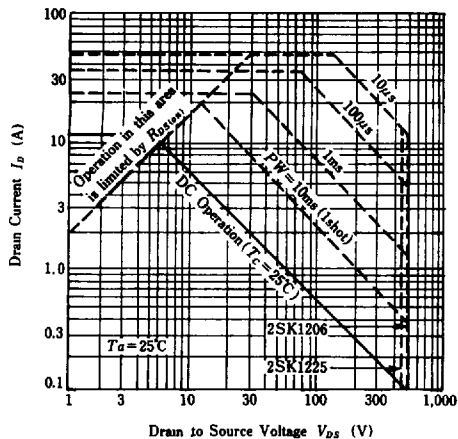

**TYPICAL OUTPUT CHARACTERISTICS**

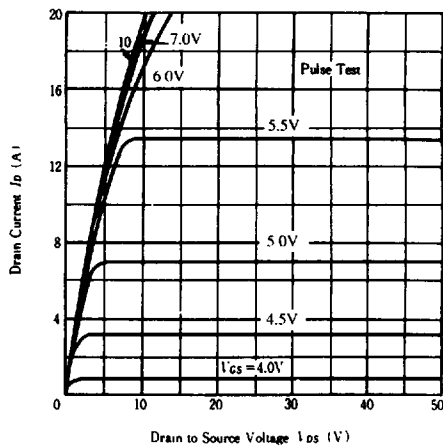

**TYPICAL TRANSFER CHARACTERISTICS**

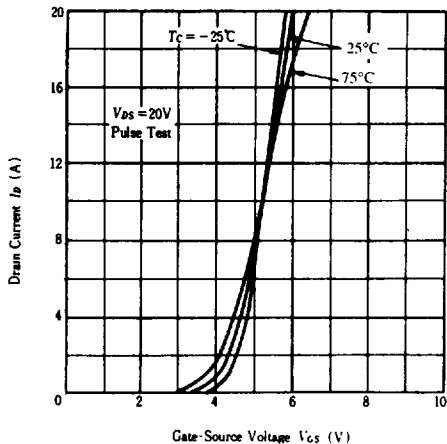

**DRAIN-SOURCE SATURATION VOLTAGE VS. GATE-SOURCE VOLTAGE**

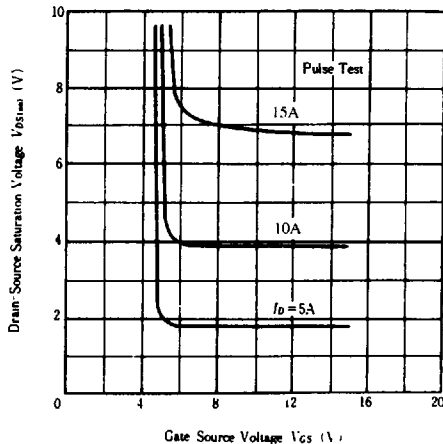

**STATIC DRAIN-SOURCE ON STATE RESISTANCE VS. DRAIN CURRENT**

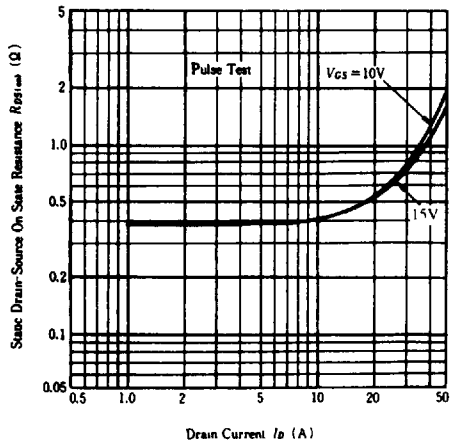

**STATIC DRAIN-SOURCE ON STATE RESISTANCE VS. TEMPERATURE**

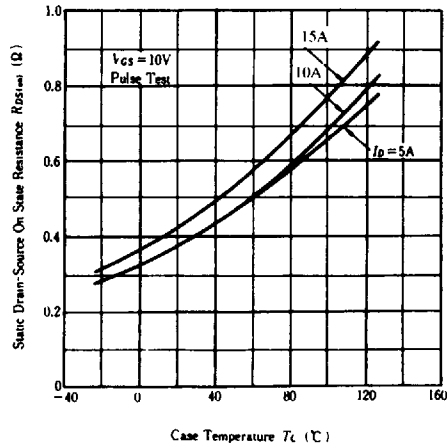

**FORWARD TRANSFER ADMITTANCE VS. DRAIN CURRENT**

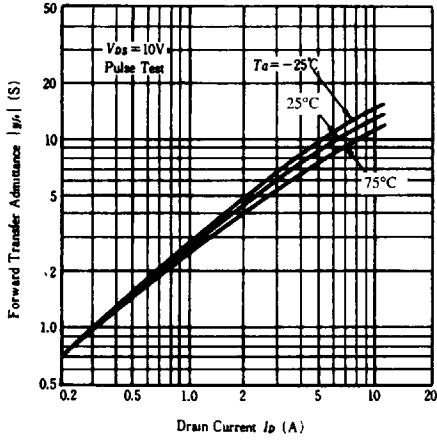

**FORWARD TRANSFER ADMITTANCE VS. FREQUENCY**

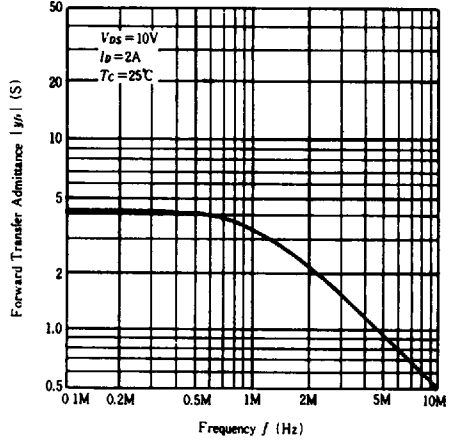

**HITACHI/(OPTOELECTRONICS)**

**TYPICAL CAPACITANCE VS. DRAIN-SOURCE VOLTAGE**

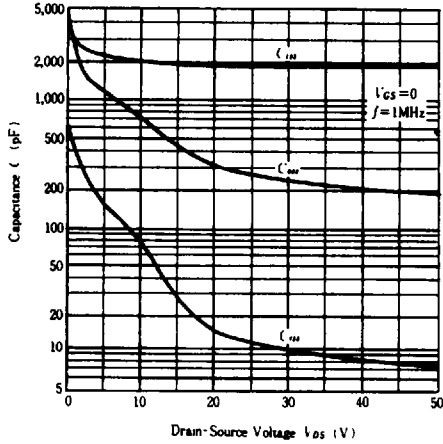

**DYNAMIC INPUT CHARACTERISTICS**

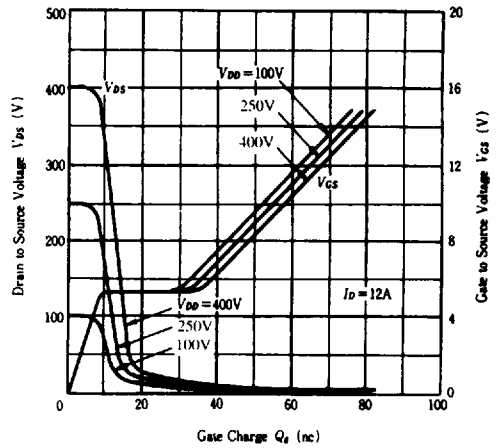

**SWITCHING CHARACTERISTICS**

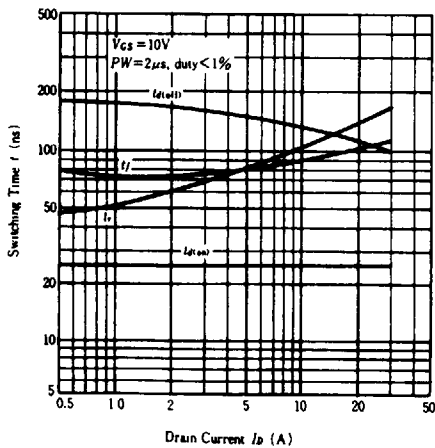

**REVERSE DRAIN CURRENT VS. SOURCE DRAIN VOLTAGE**

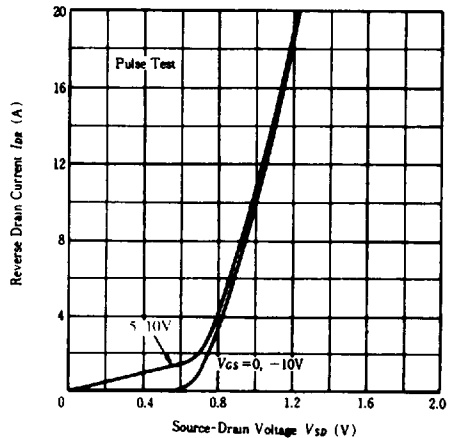

HITACHI/(OPTOELECTRONICS)

NORMALIZED TRANSIENT THERMAL IMPEDANCE VS. PULSE WIDTH

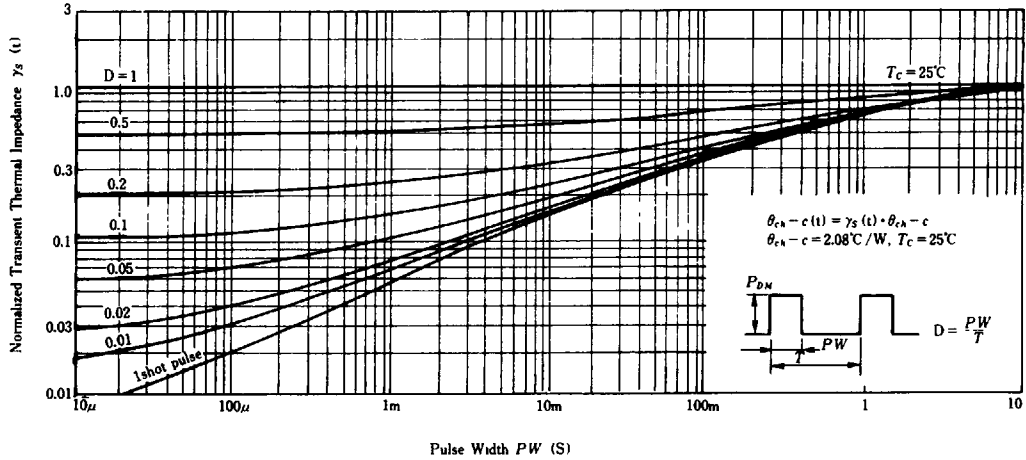

SWITCHING TIME TEST CIRCUIT

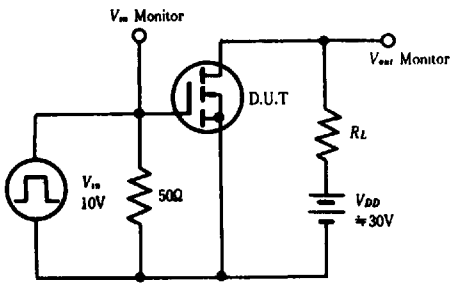

WAVEFORMS

