

Solid State Relays

Industrial, 1-Phase ZS (IO), High Volt./Current Range

Types RA 60 50 -D 16, RA .. 90 -D .., RA .. 110 -D..



- High-current, high-voltage
- AC Solid State Relay
- Zero switching or instant-on switching
- Rated operational current: 50, 90 and 110 AACrms
- Non-repetitive voltage: U_p to 1600 V_p
- Rated operational voltage: Up to 600 VACrms
- High surge current capability
- Insulation: OPTO (input-output) 4000 VACrms

Product Description

These high-current, high-voltage solid state relays are designed for ON-OFF or phase controlling of high-power AC applications. High current and high dV/dt capabilities will allow switching of inductive loads e.g. transformers, motors, val-

ves and solenoids as well as all resistive loads. Both a zero crossing and an instant-on drive circuit will minimize the negative effects of different load types. Optocouplers provide an ideal interface to logic level DC-outputs.

Ordering Key

RA 60 110 -D 16

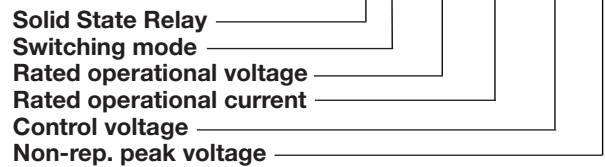

Type Selection

Switching mode	Rated operational voltage	Rated operational current	Control voltage	Non-rep. voltage
A: Zero switching	24: 230 VACrms	50: 50 AACrms	-D: 4.5 to 32 VDC	06: 650 V _p
Optional:	40: 400 VACrms	90: 90 AACrms		10: 1000 V _p
B: Instant-on switching	48: 480 VACrms	110: 110 AACrms		12: 1200 V _p
	60: 600 VACrms			16: 1600 V _p

Selection Guide

Rated operational voltage	Non-rep. voltage	Control voltage	Rated operational current		
			50 AACrms	90 AACrms	110 AACrms
230 VACrms	650 V _p	4.5 to 32 VDC	*	RA 2490 -D 06	RA 24110-D 06
400 VACrms	1000 V _p	4.5 to 32 VDC	*	RA 4090 -D 10	RA 40110-D 10
480 VACrms	1200 V _p	4.5 to 32 VDC	*	RA 4890 -D 12	RA 48110-D 12
600 VACrms	1600 V _p	4.5 to 32 VDC		RA 6050 -D 16	RA 6090 -D 16

* Please refer to standard range, RA-relays.

General Specifications

	RA 24 .. -D 06	RA 40 .. -D 10	RA 48 .. -D 12	RA 60 .. -D 16
Operational voltage range	24 to 280 VACrms	24 to 440 VACrms	24 to 530 VACrms	24 to 690 VACrms
Non-rep. peak voltage	≥ 650 V _p	≥ 1000 V _p	≥ 1200 V _p	≥ 1600 V _p
Zero voltage turn-on	≤ 15 V	≤ 15 V	≤ 15 V	≤ 20 V
Operational frequency range	45 to 65 Hz	45 to 65 Hz	45 to 65 Hz	45 to 65 Hz
Power factor	≥ 0.5 @ 400 VACrms	≥ 0.5 @ 400 VACrms	≥ 0.5 @ 480 VACrms	≥ 0.5 @ 690 VACrms
Approvals	CSA, UL	CSA, UL	CSA, UL	CSA (max 600 VAC), UL
CE-marking	Yes	Yes	Yes	Yes



Input Specifications

Control voltage range	4.5 to 32 VDC
Pick-up voltage	≤ 4.5 VDC
Drop-out voltage	≥ 1 VDC
Input current @ max. input voltage	≤ 40 mA
Reverse voltage	≤ 32 VDC
Response time pick-up	
RA	≤ 1/2 cycle
RB	≤ 1 ms
Response time drop-out	≤ 1/2 cycle

Insulation

Rated insulation voltage	
Input to output	≥ 4000 VACrms
Rated insulation voltage	
Output to case	≥ 4000 VACrms
Insulation resistance	
Input to output	≥ 10 ¹⁰ Ω
Insulation resistance	
Output to case	≥ 10 ¹⁰ Ω
Insulation capacitance	
Input to output	≤ 16 pF
Insulation capacitance	
Output to case	≤ 100 pF

Output Specifications

	RA 60 50 -D 16	RA .. 90 -D ..	RA .. 110 -D ..
Rated operational current AC 1	50 Arms	90 Arms	110 Arms
AC 3	15 Arms	20 Arms	30 Arms
Minimum operational current	20 mArms	20 mArms	20 mArms
Rep. overload current t=1 s	≤ 75 Arms	≤ 150 Arms	≤ 200 Arms
Non-rep. surge current t=20 ms	600 A _p	1000 A _p	≤ 1500 A _p
Off-state leakage current @ rated voltage and frequency	≤ 2 mArms	≤ 2 mArms	≤ 5 mArms
I ² t for fusing t=1-10 ms	≤ 1800 A ² s	≤ 5000 A ² s	≤ 11,250 A ² s
Critical di/dt	≥ 100 A/μs	≥ 100 A/μs	≥ 100 A/μs
On-state voltage drop @ rated current	≤ 1.6 Vrms	≤ 1.6 Vrms	≤ 1.6 Vrms
Critical dV/dt commutating	≥ 500 V/μs	≥ 500 V/μs	≥ 500 V/μs
Critical dV/dt off-state	≥ 500 V/μs	≥ 500 V/μs	≥ 500 V/μs

Thermal Specifications

	RA 60 50 -D 16	RA .. 90 -D ..	RA .. 110 -D ..
Operating temperature	-20° to +70°C (-4° to +158°F)	-20° to +70°C (-4° to +158°F)	-20° to +70°C (-4° to +158°F)
Storage temperature	-40° to +100°C (-40° to +212°F)	-40° to +100°C (-40° to +212°F)	-40° to +100°C (-40° to +212°F)
Junction temperature	≤ 125°C (257°F)	≤ 125°C (257°F)	≤ 125°C (257°F)
R _{th} junction to case	≤ 0.65 K/W	≤ 0.35 K/W	≤ 0.3 K/W
R _{th} junction to ambient	≤ 12 K/W	≤ 12 K/W	≤ 12 K/W

Wiring Diagram

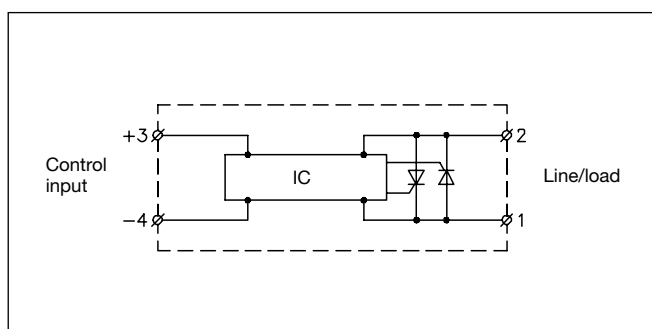

Functional Diagram

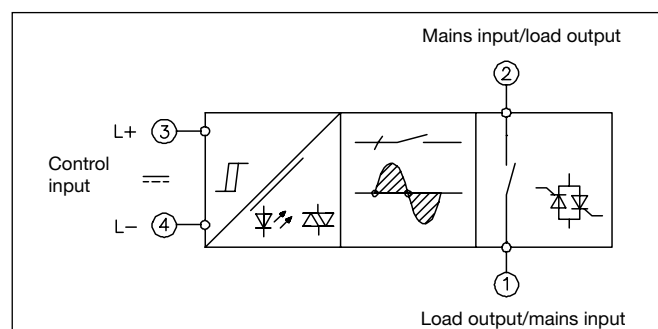

Heatsink Dimensions (load current versus ambient temperature)

RA 60 50 -D 16

Load current [A]	Thermal resistance [K/W]						Power dissipation [W]
	20	30	40	50	60	70	
50	0.92	0.76	0.60	0.45	0.29	-	63
45	1.2	0.99	0.80	0.62	0.44	0.26	55
40	1.5	1.3	1.1	0.85	0.63	0.42	47
35	1.9	1.6	1.4	1.1	0.89	0.63	40
30	2.4	2.1	1.8	1.5	1.2	0.91	33
25	3	2.7	2.3	1.9	1.5	1.1	26
20	3.9	3.5	3	2.5	2	1.5	20
15	5.5	4.8	4.1	3.4	2.7	2.1	15
10	8.6	7.5	6.4	5.4	4.3	3.2	9
5	17.9	15.6	13.4	11.2	8.9	6.7	4

Ambient temp. [°C]

RA .. 90 .. -D ..

Load current [A]	Thermal resistance [K/W]						Power dissipation [W]
	20	30	40	50	60	70	
90	0.63	0.53	0.42	0.32	-	-	97
80	0.81	0.69	0.57	0.45	0.33	-	84
70	1	0.89	0.75	0.61	0.47	0.33	71
60	1.3	1.2	1	0.83	0.66	0.49	59
50	1.7	1.5	1.3	1.1	0.85	0.64	47
40	2.2	1.9	1.7	1.4	1.1	0.83	36
30	3.1	2.7	2.3	1.9	1.5	1.2	26
20	4.8	4.2	3.6	3	2.4	1.8	17
10	10	8.8	7.5	6.3	5	3.8	8

Ambient temp. [°C]

RA.. 110-D ..

Load current [A]	Thermal resistance [K/W]						Power dissipation [W]
	20	30	40	50	60	70	
110	0.43	0.35	0.27	-	-	-	126
90	0.63	0.53	0.42	0.32	-	-	97
80	0.81	0.69	0.57	0.45	0.33	-	84
70	1	0.89	0.75	0.61	0.47	0.33	71
60	1.3	1.2	1	0.83	0.66	0.49	59
50	1.7	1.5	1.3	1.1	0.85	0.64	47
40	2.2	1.9	1.7	1.4	1.1	0.83	36
30	3.1	2.7	2.3	1.9	1.5	1.2	26
20	4.8	4.2	3.6	3	2.4	1.8	17
10	10	8.8	7.5	6.3	5	3.8	8

Ambient temp. [°C]

Heatsink Selection

Carlo Gavazzi Heatsink (see Accessories)	Thermal resistance
No heatsink required	$R_{th\ s-a} > 12.5$ K/W
RHS 100 Assy	3.0 K/W
RHS 301 Assy	0.8 K/W
RHS 301 F Assy	0.25 K/W
Consult your distributor	< 0.25 K/W

Compare the value found in the load current versus temperature chart with the standard heatsink values and select the heatsink with the next lower value.

Applications

This relay is designed for use in applications in which it is exposed to high surge conditions. Care must be taken to ensure proper heatsinking when the relay is to be used at high sustained currents. Adequate electrical connection between relay terminals and cable must be ensured.

Thermal characteristics

The thermal design of Solid State Relays is very important.

It is essential that the user makes sure that cooling is adequate and that the maximum junction temperature of the relay is not exceeded.

If the heatsink is placed in a small closed room, control panel or the like, the power dissipation can cause the ambient temperature to rise. The heatsink is to be calculated on the basis of the ambient temperature and the increase in temperature.

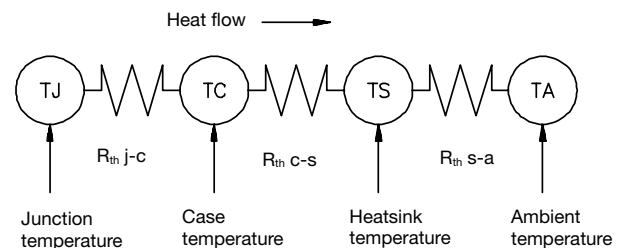

Thermal resistance:
 $R_{th\ j-c}$ = junction to case

$R_{th\ c-s}$ = case to heatsink
 $R_{th\ s-a}$ = heatsink to ambient

Applications (cont.)

Motor start application (3-phase motors)

Starting time: 5 s max.

Running time/starting time ratio ≥ 10 .

Selection Guide

Motor size [kW]	Mains voltage	Relay type	Varistor voltage ¹⁾	Heatsink ²⁾	Full load current	Fuse type
11 kW	230/400 VAC	RA 40 90 -D 10	420 V	1 K/W	24 A	6.621 CP URD 22x58/100
18.5 kW	230/400 VAC	RA 40 110 -D 10	420 V	0.5 K/W	39 A	6.621 CP URQ 27x60/160
15 kW	280/480 VAC	RA 48 90 -D 12	480 V	1 K/W	27 A	6.621 CP URD 22x58/80
22 kW	280/480 VAC	RA 48 110 -D 12	480 V	0.5 K/W	34 A	6.621 CP URD 22x58/100
7.5 kW	400/600 VAC	RA 60 50 -D 16	690 V	3 K/W	11 A	6.621 CP URD 22x58/50
18.5 kW	400/600 VAC	RA 60 90 -D 16	690 V	1 K/W	25 A	6.621 CP URD 22x58/80
30 kW	400/600 VAC	RA 60 110 -D 16	690 V	0.5 K/W	39 A	6.621 CP URD 27x58/100

¹⁾ Varistor diameter min. 20 mm

²⁾ Max. ambient temperature 50°C (one relay per heatsink)

3-phase switching circuit or 2-phase switching circuit

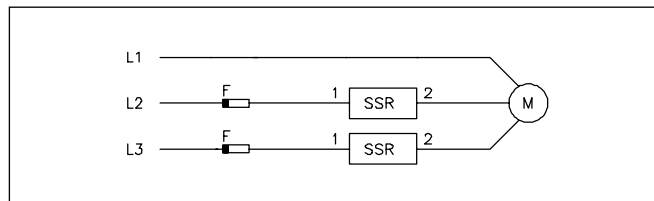
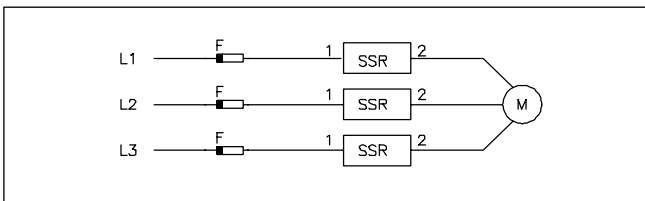

Dimensions

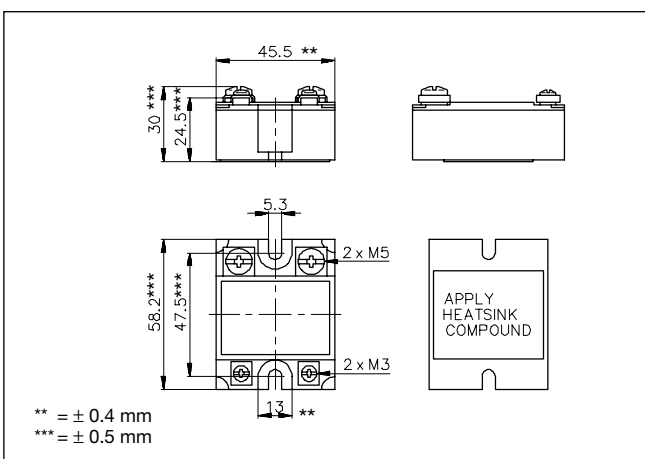

Housing Specifications

Weight	Approx. 110 g
Housing material	Noryl GFN 1, black
Base plate	Aluminium, nickel-plated
50 A type	Copper, nickel-plated
90 and 110 A types	
Potting compound	Polyurethane
Relay	
Mounting screws	M5
Mounting torque	≤ 1.5 Nm
Control terminal	
Mounting screws	M3 x 6
Mounting torque	≤ 0.5 Nm
Power terminal	
Mounting screws	M5 x 6
Mounting torque	≤ 2.4 Nm

Accessories

Protection cover
Heatsinks
DIN rail adapter
Varistors
Fuses

For further information refer to "General Accessories".