

**PLEASE CHECK WWW.MOLEX.COM FOR LATEST PART INFORMATION**

**Part Number:** [0082245912](#)  
**Status:** **Active**  
**Description:** 2.54mm (.100") Pitch Round Conductor Flat Cable - 24 AWG (7 x 32) Stranded, Topcoat, 12 Circuits, Reel 30.48m (100.0' ) Length

**Documents:**

[Drawing \(PDF\)](#) [RoHS Certificate of Compliance \(PDF\)](#)

**Agency Certification**

CSA LR61126  
 UL E61522

**General**

Product Family Cable  
 Series [8997](#)  
 Crimp Quality Equipment Yes  
 Geographic Area Asia  
 Product Name Ribbon

**Physical**

Cable Length 30.48m (100.0' )  
 Circuits (Loaded) 12  
 Insulation PVC  
 Packaging Type Reel  
 Pitch - Term. Interface (in) 0.100 In  
 Pitch - Term. Interface (mm) 2.54 mm  
 Temperature Range - Operating -20°C to +105°C  
 Wire Size AWG 24  
 Wire/Cable Type (7x32) Stranded, Topcoat

**Electrical**

Current - Maximum per Contact N/A  
 Voltage - Maximum 300V

**Material Info**

Old Part Number 8997-12-100B

**Reference - Drawing Numbers**

Sales Drawing SD-8997-001



**EU RoHS**

**ELV and RoHS  
 Compliant  
 REACH SVHC  
 Not Reviewed  
 Halogen-Free  
 Status  
 Not Reviewed**

**China RoHS**



**Need more information on product environmental compliance?**

Email [productcompliance@molex.com](mailto:productcompliance@molex.com)  
 For a multiple part number RoHS Certificate of Compliance, [click here](#)

Please visit the [Contact Us](#) section for any non-product compliance questions.

**Search Parts in this Series**

[8997Series](#)

**Use With**

[70400](#) C-Grid SL™ IDT Connector Assembly. [70475](#) SL™ IDT Connector Assembly. [7720](#) KK® IDT Double Cantilever Contact

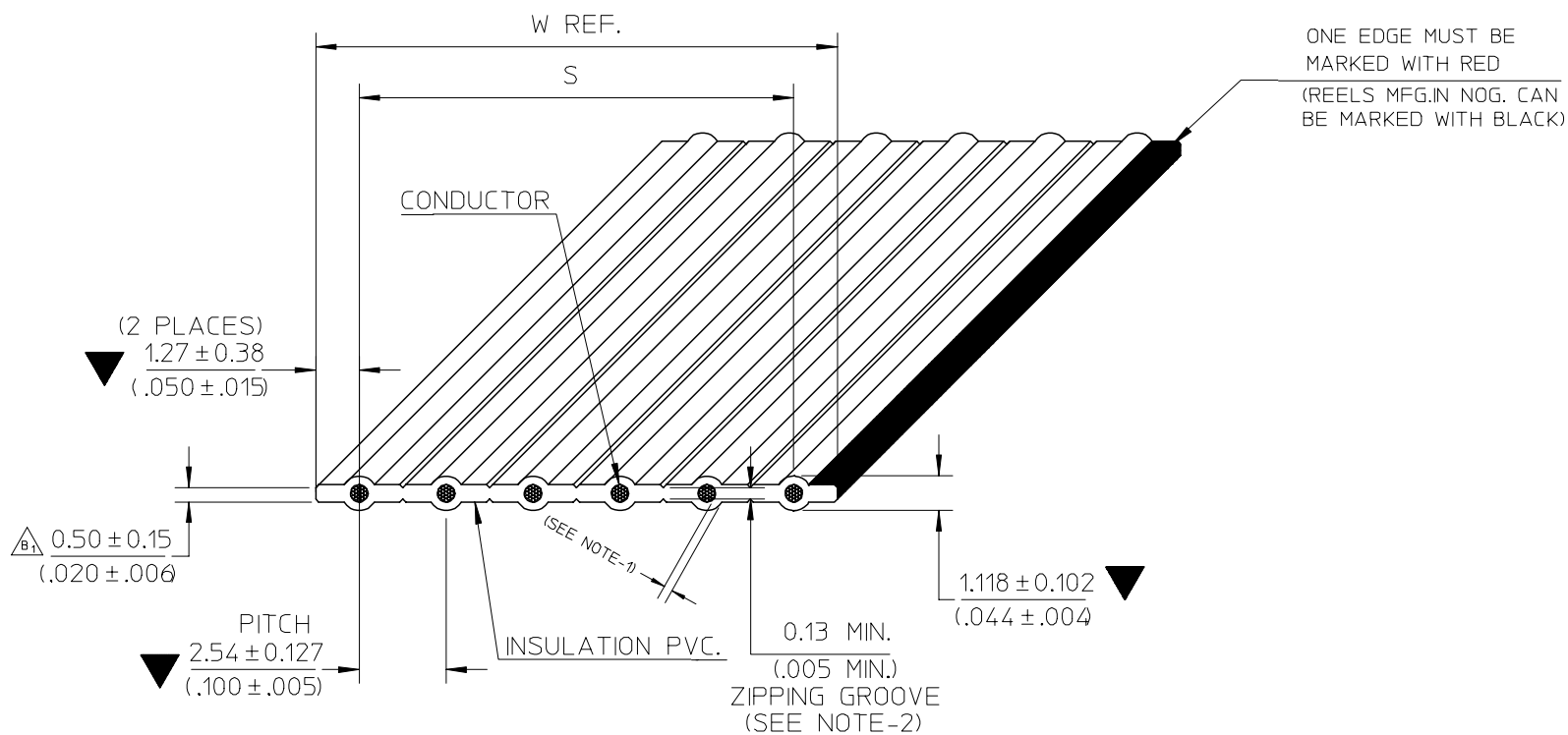

- NOTE :**
1. THE CABLE SHALL HAVE A MINIMUM OF 0.178mm. (.007") THICKNESS INSULATION AT ANY POINT
  2. RIP TEST:
    - THE 0.13mm. (.005") ZIPPING GROOVE SHALL BE CAPABLE OF BEING RIPPED BY HAND WITHIN THE RECESS, WITHOUT EXPOSING THE ADJACENT CONDUCTORS
  3. RoHS AND LEAD FREE COMPLIANT
  4. SPECIAL REQUIREMENT: N/A

B	E-07-0748	B <sub>4</sub> : ADD NON-OPERATING TEMP. B <sub>3</sub> : ADD SOLDERING CONDITION B <sub>2</sub> : CHANGE ELECTRICAL B <sub>1</sub> : CHANGE WEB THICKNESS	07/09/26
A	N/A	NEW RELEASE	06/07/18
REV. HISTORY	EC NO.	DETAIL	DATE

SEE CHANGE DETAIL  
EC NO: THL2008-0015  
DRWN: CPANSAKHOM 2007/11/28  
CHKD: DNARINTARA 2007/11/29  
APPR: SVIRATJAPOL 2007/12/04

QUALITY SYMBOLS	DESCRIPTION
▽=3	
▽=0	
REV	

GENERAL TOLERANCES (UNLESS SPECIFIED)	
	mm      INCH
4 PLACES	± ---      ± ---
3 PLACES	± ---      ± ---
2 PLACES	± ---      ± ---
1 PLACE	± ---      ± ---
ANGULAR ± ---°	
DRAFT WHERE APPLICABLE MUST REMAIN WITHIN DIMENSIONS	

DIMENSION STYLE MM/IN	
DRAWN BY	DATE
CPANSAKHOM	2006/07/18
CHECKED BY	DATE
PMEECHAI	2006/07/18
APPROVED BY	DATE
SVIRATJAPOL	2006/07/18
MATERIAL NO. SEE CHART	
SIZE	
A 4	

SCALE NTS	DESIGN UNITS INCH	THIRD ANGLE PROJECTION
TITLE FCB ROUND CONDUCTOR 2.54MM(.100)CENTER PVC. 24AWG STRANDED TOPCOATED		
MOLEX INCORPORATED		
MATERIAL NO. SEE CHART	DOCUMENT NO. SD-8997-001	SHEET NO. 1 OF 3
THIS DRAWING CONTAINS INFORMATION THAT IS PROPRIETARY TO MOLEX INCORPORATED AND SHOULD NOT BE USED WITHOUT WRITTEN PERMISSION		

SPECIFICATIONS

PHYSICAL

CONDUCTOR SPACING ----- 2.54 (.100")  $\bar{C}$  TO  $\bar{C}$   
 WIRE GAUGE ----- 24 AWG(7/32) STRANDED TOPCOATED  
 INSULATION ----- P.V.C GRAY (LEAD FREE)

AGENCY

U.L. STYLE NO. ----- 2651  
 TEMPERATURE RATING ----- -20°C TO 105°C  
 VOLTAGE RATING ----- 300V.MAX.  
 FLAMMABILITY RATING ----- VW-1

$\triangle_{B_2}$  ELECTRICAL

CONDUCTOR RESISTANCE (D.C.) ----- 27m. OHMS/FT. MAX.  
 CHARACTERISTIC IMPEDANCE ----- 134 OHMS NOM. (GS)  
 114 OHMS NOM. (GSG)  
 CAPACITANCE ----- 6.6 pF/FT. NOM. (GS)  
 12.0 pF/FT. NOM. (GSG)  
 PROPAGATION DELAY ----- 1.4 ns/FT. NOM.  
 INSULATION RESISTANCE ----- 10M OHMS (10FT. SAMPLE)  
 DIELECTRIC WITHSTAND VOLTAGE ----- 2000 VRMS/MINUTE

GENERAL

$\triangle_{B_4}$  NON-OPERATING TEMPERATURE ----- -20°C TO 105°C  
 FAULTS AND/OR SPLICES ----- 1/REEL MAX. 100 $^{+3}_0$  FT. (30.48 $^{+0.914}_0$  M.)/REEL  
 20FT. (6.096M.) MIN. LENGTH

$\triangle_{B_3}$  SOLDERING CONDITION

SOLDER TEMPERATURE ----- 260°C. MAX.  
 SOLDERING TIME ----- 3 SECOND, MAX.  
 INSULATION SHRINK ----- 2MM. NOM.

SEE CHANGE DETAIL EC NO: THL2008-0015 DRWN: CPANSAKHOM 2007/11/28 CHKD: DNARINTARA 2007/11/29 APPR: SVIRATJAPOL 2007/12/04	DESCRIPTION REV	QUALITY SYMBOLS	GENERAL TOLERANCES (UNLESS SPECIFIED)		DIMENSION STYLE		SCALE	DESIGN UNITS	THIRD ANGLE PROJECTION		
		$\blacktriangledown =$ $\triangle =$	mm	INCH	MM/IN		NTS	INCH	DRAWN BY CPANSAKHOM DATE 2006/07/18 CHECKED BY PREECHAI DATE 2006/07/18 APPROVED BY SVIRATJAPOL DATE 2006/07/18 MATERIAL NO. SEE CHART DOCUMENT NO. SD-8997-001 SHEET NO. 2 OF 3		
			4 PLACES $\pm$ ----	$\pm$ ----	DRAWN BY DATE		TITLE				
		DRAFT WHERE APPLICABLE MUST REMAIN WITHIN DIMENSIONS		ANGULAR $\pm$ ----		MATERIAL NO. SEE CHART		DOCUMENT NO. SD-8997-001		FCB ROUND CONDUCTOR 2.54MM(.100)CENTER PVC. 24AWG STRANDED TOPCOATED MOLEX INCORPORATED	

E

E

CHART A				
DIMENSIONS MM. (INCHES)				
ENGINEERING NO.	ORDER NO.	NO. OF CONDUCTOR	DIMENSION S	DIM. W (REF.)
8997-02-100B	82-24-5902	2	2.54±0.127(.100±.005)	5.08 (.200)
↑ -03- ↑	↑ 03	3	5.08±0.20 (.200±.008)	7.62 (.300)
-04-	04	4	7.62±0.30 (.300±.012)	10.16 (.400)
-05-	05	5	10.16±0.33 (.400±.013)	12.70 (.500)
-06-	06	6	12.70±0.33 (.500±.013)	15.24 (.600)
-07-	07	7	15.24±0.33 (.600±.013)	17.78 (.700)
-08-	08	8	17.78±0.33 (.700±.013)	20.32 (.800)
-09-	09	9	20.32±0.33 (.800±.013)	22.86 (.900)
-10-	10	10	22.86±0.33 (.900±.013)	25.40 (1.000)
-11-	11	11	25.40±0.33 (1.000±.013)	27.94 (1.100)
-12-	12	12	27.94±0.33 (1.100±.013)	30.48 (1.200)
-13-	13	13	30.48±0.33 (1.200±.013)	33.02 (1.300)
-14-	14	14	33.02±0.33 (1.300±.013)	35.56 (1.400)
-15-	15	15	35.56±0.33 (1.400±.013)	38.10 (1.500)
-16-	16	16	38.10±0.33 (1.500±.013)	40.64 (1.600)
-17-	17	17	40.64±0.33 (1.600±.013)	43.18 (1.700)
-18-	18	18	43.18±0.33 (1.700±.013)	45.72 (1.800)
↓ -19- ↓	↓ 19	19	45.72±0.33 (1.800±.013)	48.26 (1.900)
8997-20-100B	82-24-5920	20	48.26±0.33 (1.900±.013)	50.80 (2.000)

ENGINEERING NO.

8997-XX-XXXX  
 A B C D

- A : CABLE 2.54mm. (.100") CENTERS 24AWG STRANDED TOPCOATED
- B : CONDUCTOR SIZE ( AVAILABILITY 2 THROUGH 20 )
- C : CABLE LENGTH 100FT. (30.48M.)
- D : A = INCHES  
B = FEET

D

D

C

C

B

B

A

A

SEE CHANGE DETAIL EC NO: THL2008-0015 DRWN: CPANSAKHOM 2007/11/28 CHKD: DNARINTARA 2007/11/29 APPR: SVIRATJAPOL 2007/12/04	QUALITY SYMBOLS	GENERAL TOLERANCES (UNLESS SPECIFIED)		DIMENSION STYLE	SCALE	DESIGN UNITS	THIRD ANGLE PROJECTION	
	▽ = ▽ =	mm	INCH	MM/IN	NTS	INCH		
		4 PLACES ± ---	± ---	DRAWN BY	DATE	TITLE		
		3 PLACES ± ---	± ---	CPANSAKHOM	2006/07/18	FCB ROUND CONDUCTOR 2.54MM(.100)CENTER PVC. 24AWG STRANDED TOPCOATED		
		2 PLACES ± ---	± ---	CHECKED BY	DATE	MOLEX INCORPORATED		
	1 PLACE ± ---	± ---	PMEECHAI	2006/07/18				
	ANGULAR ± ---°			APPROVED BY	DATE			
		DRAFT WHERE APPLICABLE MUST REMAIN WITHIN DIMENSIONS		SVIRATJAPOL	2006/07/18			
				MATERIAL NO.	DOCUMENT NO.	SHEET NO.		
				SEE CHART	SD-8997-001	3 OF 3		
				SIZE	THIS DRAWING CONTAINS INFORMATION THAT IS PROPRIETARY TO MOLEX INCORPORATED AND SHOULD NOT BE USED WITHOUT WRITTEN PERMISSION			
				A 4				