

NON-ISOLATED DC/DC CONVERTERS

6.5 Vdc - 13.2 Vdc Input, 1.2 Vdc - 2.1 Vdc Output



Aug. 12, 2010

Bel Power Inc., a subsidiary of Bel Fuse Inc.

VRP3-90ExA0

RoHS Compliant

Rev.G

Features

- Non-Isolated
- High Efficiency
- Fixed Frequency
- Wide Input
- Remote On/Off
- IMON Pin for Output Current Monitoring
- Power State Indicator(PSI#) Pin for Phase Dropping and Higher Efficiency During Light Load States
- Class 1, Category 2, Non-Isolated DC/DC Converter (refer to IPC-9592)
- Over/Under Voltage Protection
- OCP/SCP
- 2-Wire Remote sense
- 2 bit VID Digital Voltage Programming
- Open-drain Power Good Output



Applications

- Networking
- Computers and peripherals
- Telecommunications

Description

The VRP3-90ExA0 series are non-isolated step down DC/DC converters providing up to 90 A output current. Standard features include remote on/off, remote sense, 2 bit VID digital voltage programming, a power good signal, over voltage and under voltage protection, over current protection, current monitor and power State Indicator (PSI#). This product may be used almost anywhere low-voltage silicon is being employed and a nominal 12V source is available. Typical applications include telecommunications, networking and other computing applications.

Part Selection

Output Voltage	Input Voltage	Max. Output Current	Max. Output Power	Typical Efficiency	Model Number Active High
1.21 Vdc - 2.1Vdc	6.5 Vdc - 13.2 Vdc	90 A	200 W	85%	VRP3-90E1A0
1.2 Vdc - 2.1Vdc	6.5 Vdc - 13.2 Vdc	90 A	200 W	85%	VRP3-90E2A0

Notes: Add "G" suffix at the end of the model number to indicate Tray Packaging.

Part Number Explanation

V R P3 - 90 E 1A 0
1 2 3 4 5 6 7

- 1---Vertical mount
- 2---RoHS 6, change "R" to "7" means RoHS 5
- 3---Series name, SIP
- 4---Series code, output current 90A
- 5---Wide input range (6.5-13.2V)
- 6---"1A", "2A" Wide trim range
- 7---Suffix

NON-ISOLATED DC/DC CONVERTERS

6.5 Vdc - 13.2 Vdc Input, 1.2 Vdc - 2.1 Vdc Output



Aug. 12, 2010

Bel Power Inc., a subsidiary of Bel Fuse Inc.

Absolute Maximum Ratings

Parameter	Min	Typ	Max	Unit	Notes
Continuous non-operating Input Voltage	-0.3	-	15	V	
Remote On/Off	-0.3	-	5	V	
Ambient Temperature	0	-	70	°C	
Storage Temperature	-55	-	125	°C	

Note: Ratings used beyond the maximum ratings may cause a reliability degradation of the converter or may permanently damage the device.

Input Specifications

Parameter	Min	Typ	Max	Unit	Notes
Operating Input Voltage	6.5	12	13.2	V	
Input Current (full load)	-	-	35	A	
Input Current (no load)	-	500	700	mA	
Remote Off Input Current	-	10	25	mA	
Input Reflected Ripple Current (rms)	-	10	25	mA	With simulated source impedance of 100nH, 5Hz to 20MHz. Use 2 * 470uF/16V Oscon capacitor.
Input Reflected Ripple Current (pk-pk)	-	25	50	mA	
I ² t Inrush Current Transient	-	-	1	A ² s	
Turn-on Voltage Threshold	5.4	5.7	6.0	V	
Turn-off Voltage Threshold	4.8	5.1	5.4	V	

Note: All specifications are typical at 25 °C unless otherwise stated.

Output Specifications

Parameter	Min	Typ	Max	Unit	Notes
Output Voltage Set Point VRP3-90E1A0	1.192	1.210	1.228	V	-
	1.330	1.350	1.370	V	
	1.478	1.500	1.523	V	
	2.069	2.100	2.132	V	
Output Voltage Set Point VRP3-90E2A0	1.182	1.20	1.218	V	VID1,VID0=00 VID1,VID0=01 VID1,VID0=10 VID1,VID0=11
	1.478	1.50	1.523	V	
	1.773	1.80	1.827	V	
	2.069	2.10	2.132	V	
Load regulation	-	-	12	mV	
Line Regulation	-	5	10	mV	
Regulation Over Temperature (0deg.C-70deg.C)	-	10	20	mV	
Ripple and Noise (pk-pk)	-	25	40	mV	20MHz BW, Co=3600uF.
Ripple and Noise (rms)	-	10	20	mV	
Ripple and Noise (pk-pk) under worst case	-	-	60	mV	over all operating input voltage, load and temperature conditions.
Output Current Range	0	-	90	A	
Output DC Current Limit	100	-	130	A	

NON-ISOLATED DC/DC CONVERTERS

6.5 Vdc - 13.2 Vdc Input, 1.2 Vdc - 2.1 Vdc Output



Aug. 12, 2010

Bel Power Inc., a subsidiary of Bel Fuse Inc.

Output Specifications (continued)

Parameter	Min	Typ	Max	Unit	Notes	
Turn on Delay Time	-	3.5	5	mS		
Rise Time	-	2.5	5	mS		
Overshoot at Turn on	-	-	1	%		
Output Capacitance	-	3600	-	uF		
Transient Response						
ΔV50%~100% of Max Load	Overshoot	-	-	200	mV	di/dt=2.5A/us, Vin=12Vdc, Ta=25°C, Co=3600uF
	Settling Time	-	-	150	uS	
ΔV100%~50% of Max Load	Overshoot	-	-	200	mV	
	Settling Time	-	-	150	uS	

Note: All specifications are typical at nominal input, full load at 25°C unless otherwise stated.

General Specifications

Parameter	Min	Typ	Max	Unit	Notes
Efficiency Vin =12, Vout=1.5V,Iout=90A	82	85	-	%	VRP3-90E1A0: Rtrim-up=3.79k VRP3-90E2A0: VID0=0, VID1=1
Efficiency Vin =12, Vout=1.35V,Iout=90A	81	84	-	%	VRP3-90E1A0: Rtrim-up=7.86k VRP3-90E2A0: VID0=0, VID1=1, Rtrim-down = 16.67k
Switching Frequency	-	400	-	kHz	
Over Temperature Protection	100	-	120	°C	
Over Voltage Protection	105	-	115	%Vo	Latch off
Weight	-	33	-	g	
FIT	400 (design goal)			-	Calculated Per Bell Core SR-332 (Vin=12 V, Vo=1.2 V, Io=80%load, Ta = 25 °C, FIT=10 ⁹ /MTBF)
Dimensions Inches (L x W x H) Millimeters (L x W x H)	2.00 x 1.2 x 0.70 50.8 x 30.48 x 17.8			-	

Note: All specifications are typical at 25 °C unless otherwise stated.

Efficiency Data

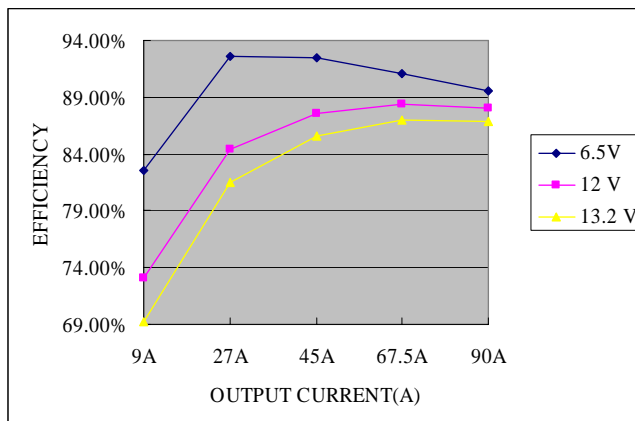

Vo=1.5V

NON-ISOLATED DC/DC CONVERTERS

6.5 Vdc - 13.2 Vdc Input, 1.2 Vdc - 2.1 Vdc Output



Aug. 12, 2010

Bel Power Inc., a subsidiary of Bel Fuse Inc.

Thermal Derating Curves

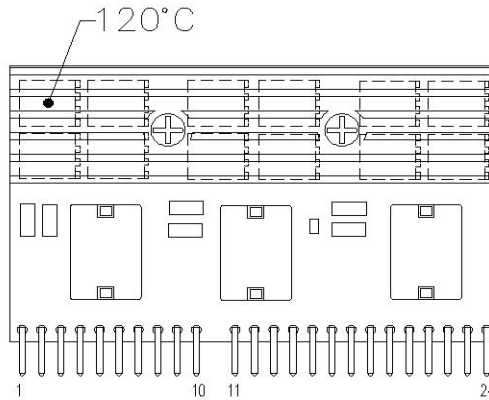

Top view

The thermal reference point is shown above. For reliable operation this temperature should not exceed 120°C. The output power of the module should not exceed the rated power for the module.

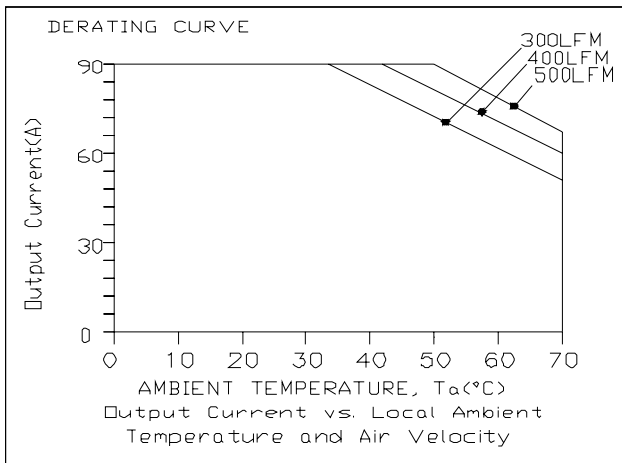

$V_{in}=12V, V_o=1.35V$

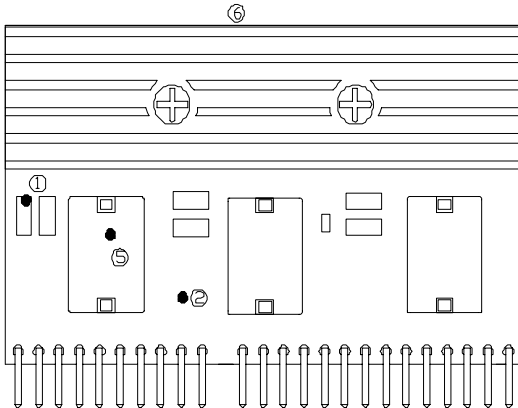

Top view

Temperature reference points on top side

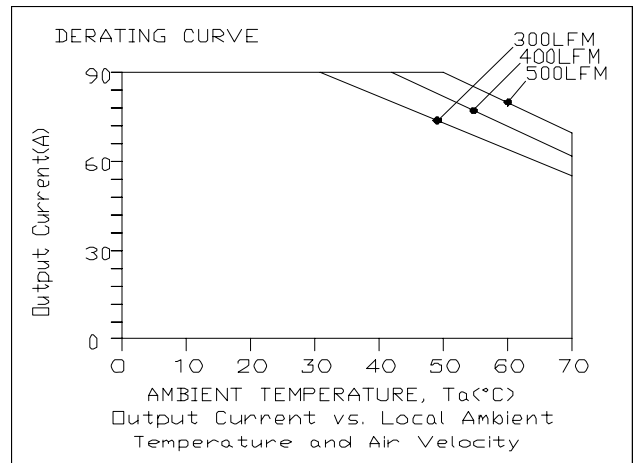

$V_{in}=12V, V_o=2.1V$

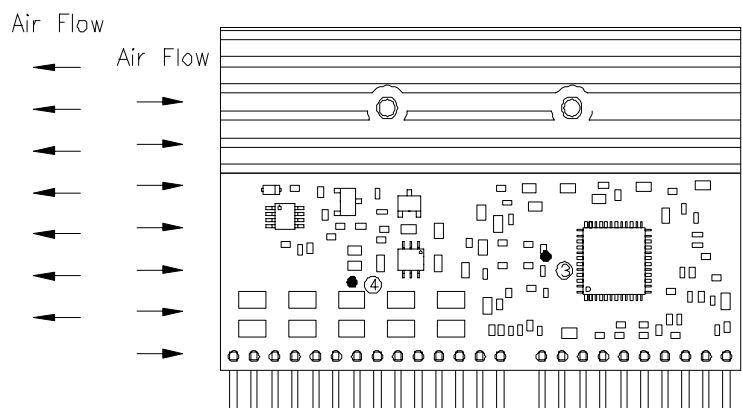

Bottom view

Temperature reference points on bottom side

NON-ISOLATED DC/DC CONVERTERS

6.5 Vdc - 13.2 Vdc Input, 1.2 Vdc - 2.1 Vdc Output



Aug. 12, 2010

Bel Power Inc., a subsidiary of Bel Fuse Inc.

Ripple and Noise Waveform

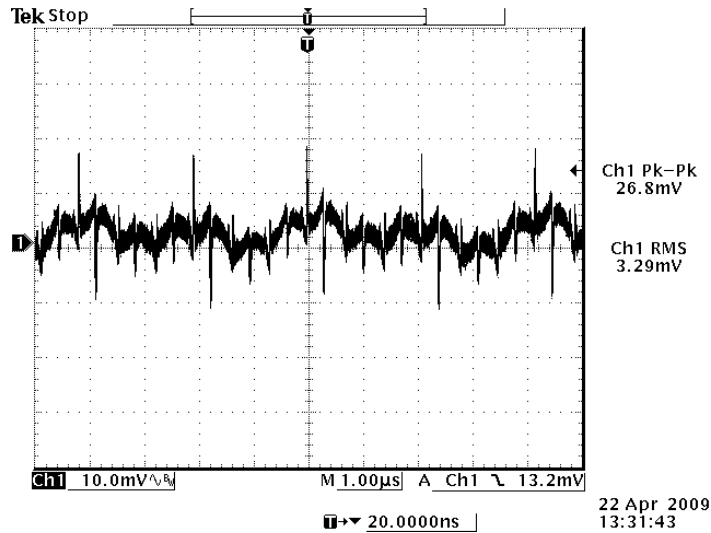

Note: Ripple and noise at 12Vdc input, Vout=1.5V, Iout=90A and Ta=25 deg C, Co=3600uF.

Transient Response Waveforms

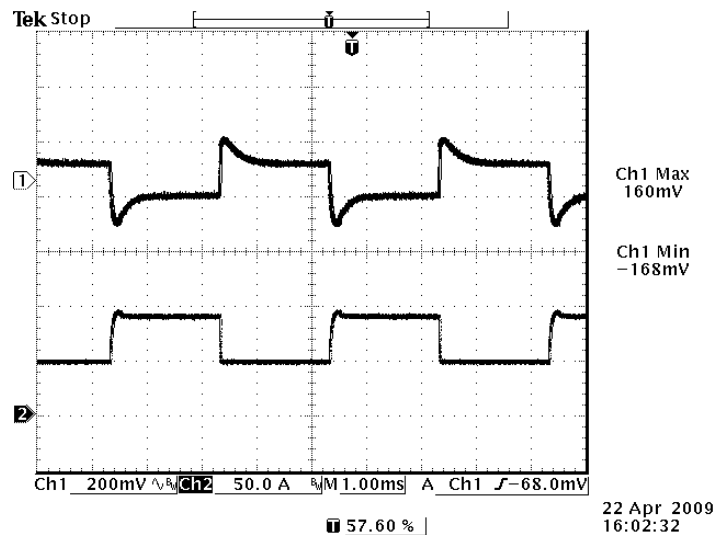

Note: Vout=1.5V, Vin=12V@Ta=25°C, Co=3600uF.

NON-ISOLATED DC/DC CONVERTERS

6.5 Vdc - 13.2 Vdc Input, 1.2 Vdc - 2.1 Vdc Output



Aug. 12, 2010

Bel Power Inc., a subsidiary of Bel Fuse Inc.

Startup & Shutdown

Rise Time

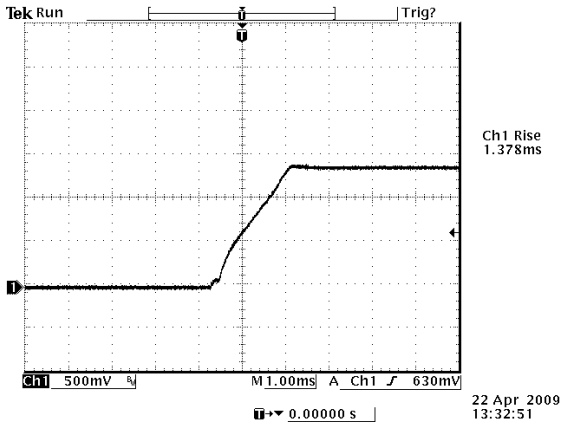

Test Condition:
12Vdc input, $V_{out}=1.5V$,
 $I_{out}=90A$ and $T_a=25$ deg C,
 $C_o=3600\mu F$

Startup time

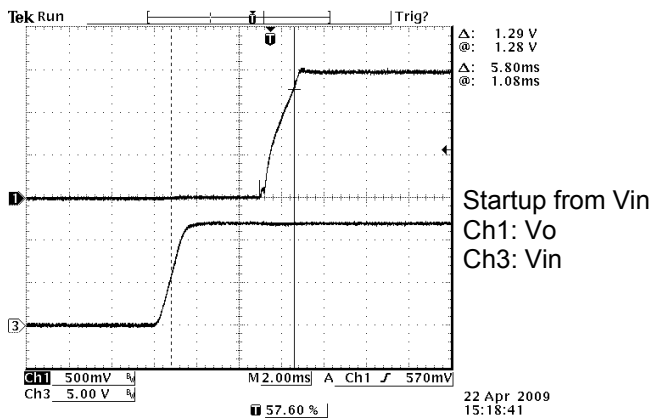

Test Condition: 12Vdc input, $V_{out}=1.5V$,
 $I_{out}=90A$ and $T_a=25$ deg C, $C_o=3600\mu F$

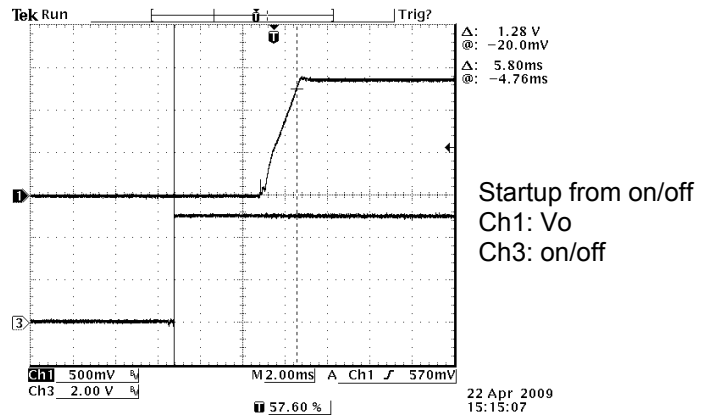

Test Condition: 12Vdc input, $V_{out}=1.5V$,
 $I_{out}=90A$ and $T_a=25$ deg C, $C_o=3600\mu F$

Shutdown

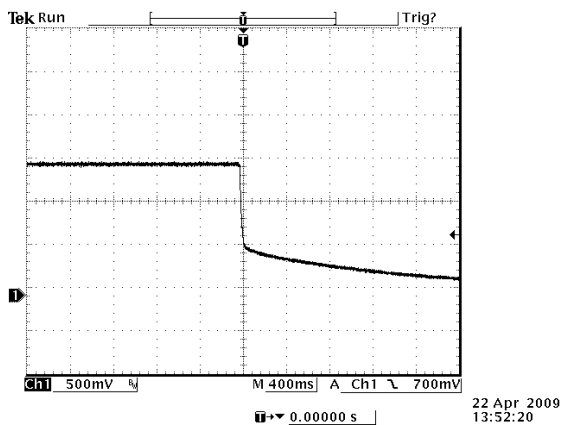

Test Condition: 12Vdc input, $V_{out}=1.5V$, $I_{out}=0A$
and $T_a=25$ deg C, $C_o=3600\mu F$

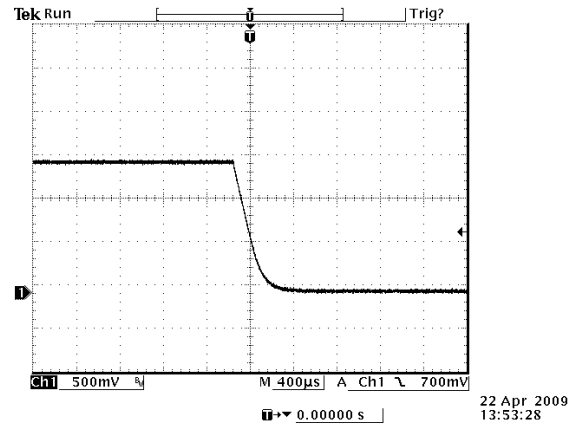

Test Condition: 12Vdc input, $V_{out}=1.5V$,
 $I_{out}=90A$ and $T_a=25$ deg C, $C_o=3600\mu F$

NON-ISOLATED DC/DC CONVERTERS

6.5 Vdc - 13.2 Vdc Input, 1.2 Vdc - 2.1 Vdc Output



Aug. 12, 2010

Bel Power Inc., a subsidiary of Bel Fuse Inc.

Remote On/Off

Parameter		Min	Typ	Max	Unit	Notes
Signal Low (Unit Off)	Active High	-0.3	-	0.8	V	The remote on/off pin open, Unit off.
Signal High (Unit On)		2.4	-	5	V	
Current Sink		0	-	1	mA	

Recommended remote on/off circuit for active high

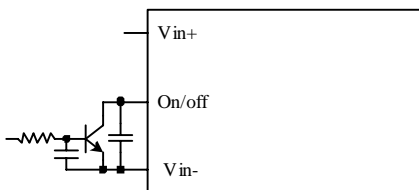

Control with open collector/drain circuit

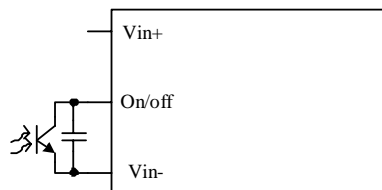

Control with photocoupler circuit

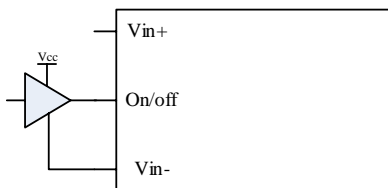

Control with logic circuit

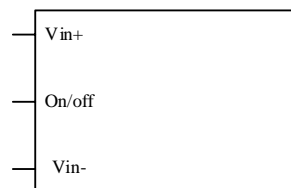

Permanently off

NON-ISOLATED DC/DC CONVERTERS

6.5 Vdc - 13.2 Vdc Input, 1.2 Vdc - 2.1 Vdc Output



Aug. 12, 2010

Bel Power Inc., a subsidiary of Bel Fuse Inc.

Remote Sense

This module has remote sense compensation feature. It can minimize the effects of resistance between module's output and load in system layout and facilitates accurate voltage regulation at load terminals or other selected point.

1. The remote sense lines carries very little current and hence do not require a large cross-sectional area.
2. This module compensates for a maximum drop of 10% of the nominal output voltage.
3. If the unit is already trimmed up, the available remote sense compensation range should be correspondingly reduced. The total voltage increased by trim and remote sense should not exceed 10% of the nominal output voltage.
4. When using remote sense compensation, all the resistance, parasitic inductance and capacitance of the system are incorporated within the feedback loop of this module. It can make an effect on the module's compensation, affecting the stability and dynamic response. A 0.1 μ F ceramic capacitor can be connected at the point of load to de-couple noise on the sense wires.
5. Recommend the connection of remote sense compensation as below figure. There are a resistor RS+ (51.1 ohm) from Vo+ to Sense+ and a resistor RS- (51.1 ohm) from Vo- to Sense- inside of this module.

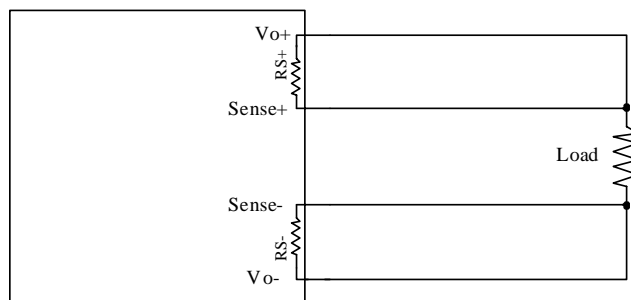

6. If not using remote sense compensation, please connect sense directly to output at module's pin, that is, connect sense+ to Vo+ and sense- to Vo- at module's pin, the shorter the better. See below figure.

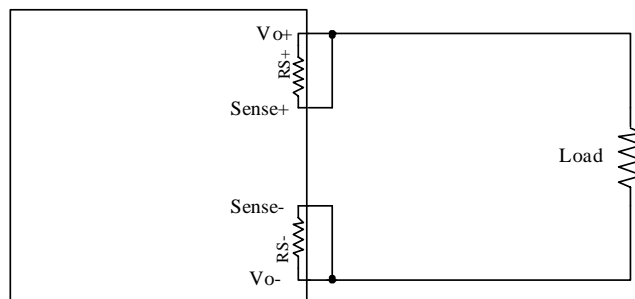

Aug. 12, 2010

Bel Power Inc., a subsidiary of Bel Fuse Inc.

Output Trim Equations

VRP3-90E1A0

Equations for calculating the trim resistor are shown below. The Rtrim resistor should be connected between the Trim pin and the Vsense(-).

Maximum trim up voltage is 2.1V.

The total voltage increased by trim and remote sense should not exceed 10% of the nominal output voltage.

$$R_{trim-up} = \frac{1.1}{V_o - 1.21} (k\Omega)$$

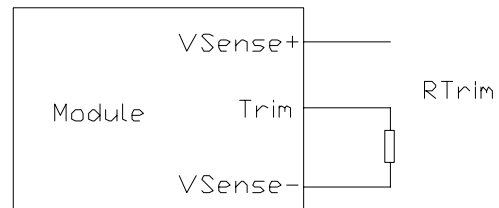

VRP3-90E2A0

Equations for calculating the trim resistor are shown below. The Trim Down resistor should be connected between the Trim pin and Sense (+) pin. The Trim Up resistor should be connected between the Trim pin and the GND. Only one of the resistors should be used for any given application.

Minimum trim down voltage is 1.1V

Maximum trim up voltage is 2.1V.

The total voltage increased by trim and remote sense should not exceed 10% of the nominal output voltage.

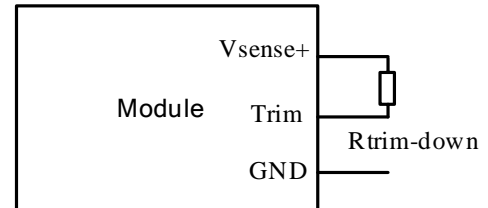
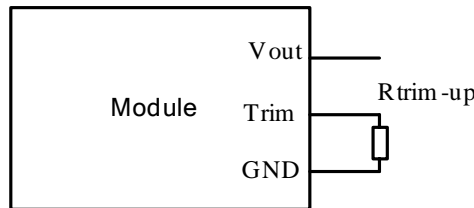

VID0	VID1	Vout	Trim up equation	Trim down equation
0	0	1.2V	$R_{trim-up} = \frac{11}{V_o - 1.2} (K\Omega)$	$R_{trim-down} = \frac{10V_o - 11}{1.2 - V_o} (K\Omega)$
0	1	1.5V	$R_{trim-up} = \frac{11}{V_o - 1.5} (K\Omega)$	$R_{trim-down} = \frac{10V_o - 11}{1.5 - V_o} (K\Omega)$
1	0	1.8V	$R_{trim-up} = \frac{11}{V_o - 1.8} (K\Omega)$	$R_{trim-down} = \frac{10V_o - 11}{1.8 - V_o} (K\Omega)$
1	1	2.1V	$R_{trim-up} = \frac{11}{V_o - 2.1} (K\Omega)$	$R_{trim-down} = \frac{10V_o - 11}{2.1 - V_o} (K\Omega)$

NON-ISOLATED DC/DC CONVERTERS

6.5 Vdc - 13.2 Vdc Input, 1.2 Vdc - 2.1 Vdc Output



Aug. 12, 2010

Bel Power Inc., a subsidiary of Bel Fuse Inc.

Over Current Protection

The module is equipped with internal current-limiting circuitry in order to provide protection in a fault output overload condition. The module will be in latch off mode when the output current exceeds the current limit and restart by either cycling the input power or by toggling the on/off pin.

Over Voltage Protection

The output over-voltage protection consists of circuitry that monitors the voltage on the output terminals. If the voltage on the output terminals exceeds the over voltage protection threshold, the module will shutdown into latch off mode. The over-voltage latch can be reset by either cycling the input power or toggling the on/off signal for one second at least.

Input Under-voltage Lockout

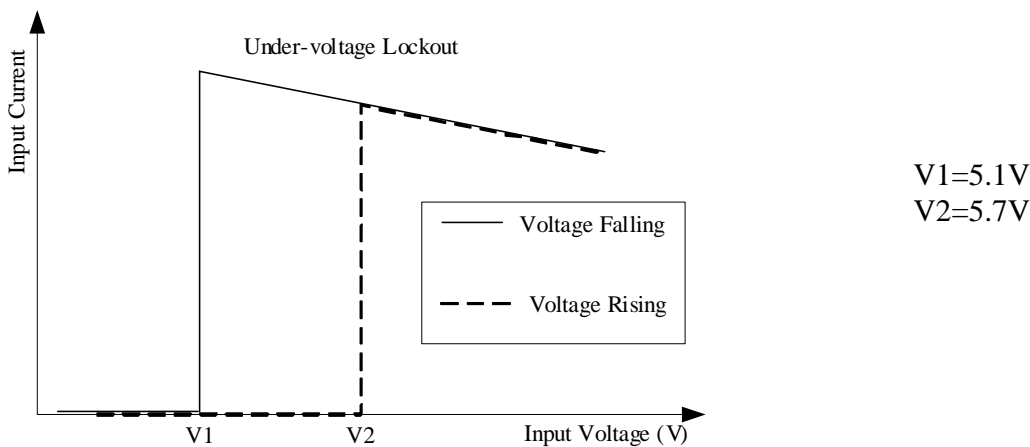

NON-ISOLATED DC/DC CONVERTERS

6.5 Vdc - 13.2 Vdc Input, 1.2 Vdc - 2.1 Vdc Output



Aug. 12, 2010

Bel Power Inc., a subsidiary of Bel Fuse Inc.

Power Good

1. This module has a power good indicator output. Power good pin used positive logic and is open collector.
2. Power good pin can sink 10mA.
3. The maximum voltage pulled up externally on Power Good pin should not exceed 6V.
4. When a successful soft-start is completed, the power good pin will be pulled high.

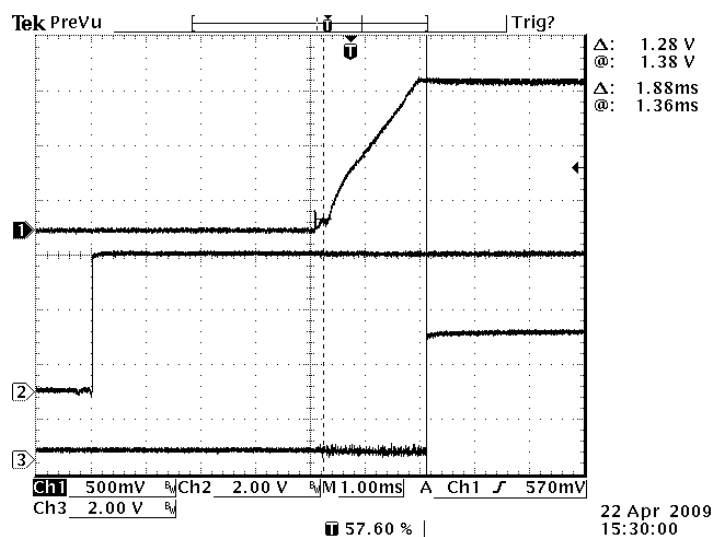

CH1: Output Voltage CH2: Remote ON/OFF CH3: PG
Typical Start-up Using Remote ON/OFF(Vin=12.0V, Vout=1.5V, Io=90A)

IMON Diagram

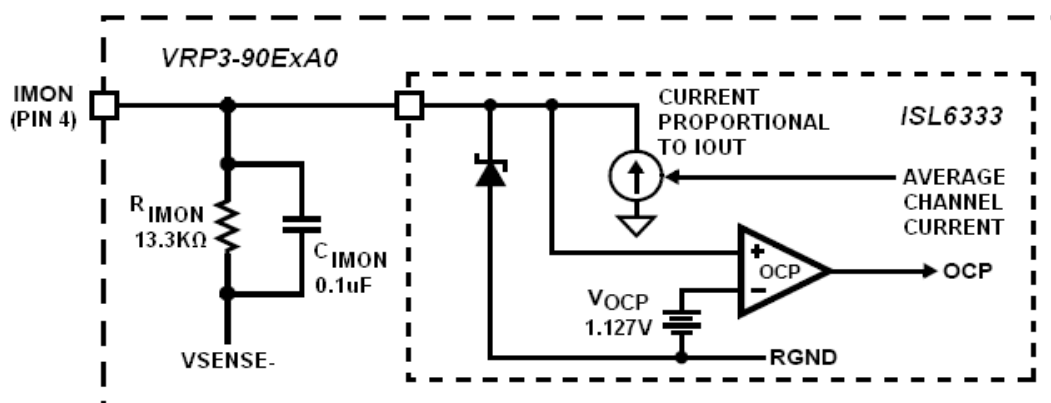

Note: The IMON pin is the average channel-current sense output. This pin is used as a load current indicator to monitor the output load current. When $I_{out} = 90A$ the voltage on the IMON pin = 900mV.

NON-ISOLATED DC/DC CONVERTERS

6.5 Vdc - 13.2 Vdc Input, 1.2 Vdc - 2.1 Vdc Output



Aug. 12, 2010

Bel Power Inc., a subsidiary of Bel Fuse Inc.

Mechanical Outline

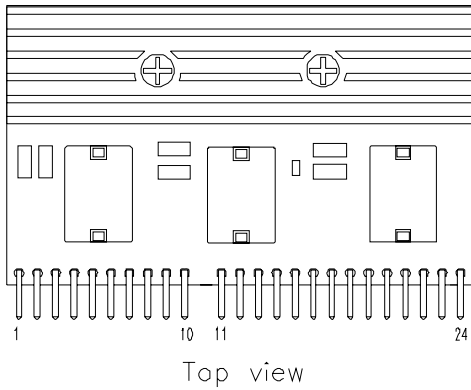
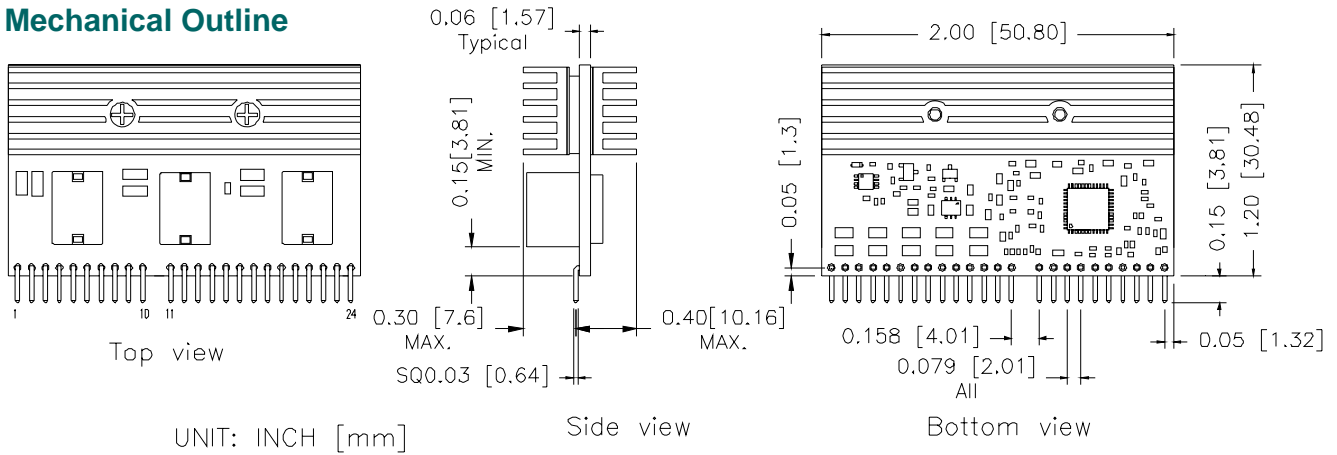

RECOMMENDED PAD LAYOUT

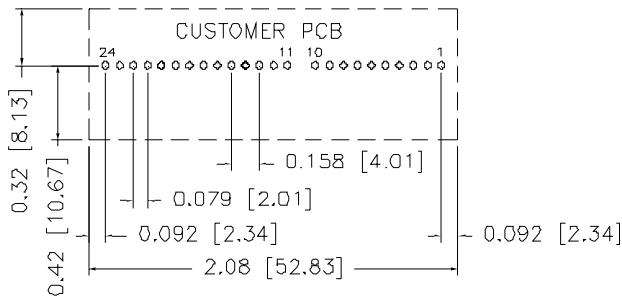

24 PIN PAD THR. HOLES: $\varnothing 0.04$ [$\varnothing 1.0$] BOTH SIDE

VRP3-90E1A0

Pin	Function	Pin	Function	Pin	Function
1	Reserved	9	PSI#	17	GND
2	Reserved	10	PGOOD	18	GND
3	Reserved	11	Vin	19	Vout
4	IMON	12	Vin	20	Vout
5	Enable	13	GND	21	GND
6	Vsense+	14	GND	22	GND
7	Vesense-	15	Vout	23	Vout
8	Trim	16	Vout	24	Vout

VRP3-90E2A0

Pin	Function	Pin	Function	Pin	Function
1	VID0	9	PSI#	17	GND
2	VID1	10	PGOOD	18	GND
3	Reserved	11	Vin	19	Vout
4	IMON	12	Vin	20	Vout
5	Enable	13	GND	21	GND
6	Vsense+	14	GND	22	GND
7	Vesense-	15	Vout	23	Vout
8	Trim	16	Vout	24	Vout

Note: This module is recommended and compatible with Pb-Free Wave Soldering and must be soldered using a peak solder temperature of no more than 260 °C for less than 5 seconds.

Note:

- 1) All Pins: Material - Copper Alloy;
Finish – 3 micro inches minimum Gold over 50 micro inches minimum Nickel plate.
- 2) Undimensioned components are shown for visual reference only.
- 3) All dimensions in inches (mm); Tolerances: x.xx +/-0.02 in. (x.x +/-0.5mm) x.xxx +/-0.010 in. (x.xx +/-0.25mm).

NON-ISOLATED DC/DC CONVERTERS

6.5 Vdc - 13.2 Vdc Input, 1.2 Vdc - 2.1 Vdc Output



Aug. 12, 2010

Bel Power Inc., a subsidiary of Bel Fuse Inc.

Signal Definitions

Pin Name	Pin Description
VID0, VID1	Logic level inputs used to set the output voltage, refer to VID table. Connect VID0 thru VID1 pins to open-drain outputs with external pull-up resistors or to active-pull-up outputs. Valid logic low is -0.3V to 0.4V, valid logic high level is 0.8V to 5.3V.
IMON	The IMON pin is the average channel-current sense output. This pin is used as a load current indicator to monitor the output load current. The voltage on the Imon pin = 900mV when Iout = 90A.
Enable	Logic level input used to enable the converter when high.
Vsense+	Positive remote sense.
Vsense-	Negative remote sense.
Trim	Output voltage Trim.
PSI#	A low input signal indicates the low power mode operation of the processor. The controller drops the number of active phases to single phase operation. A high input signal pulls the controller back to normal operation.
PGOOD	PGOOD indicates that soft-start has completed and the output voltage is within the regulated range around VID setting.
Vin	Input voltage of the converter.
GND	Common return for both input and output.
Vout	Output voltage of the converter.

NON-ISOLATED DC/DC CONVERTERS

6.5 Vdc - 13.2 Vdc Input, 1.2 Vdc - 2.1 Vdc Output



Aug. 12, 2010

Bel Power Inc., a subsidiary of Bel Fuse Inc.

Revision History

Date	Revision	Changes Detail	Approval
2009-03-17	A	First release	XF JIANG
2009-03-24	B	Updated mechanical drawing	XF JIANG
2009-04-22	C	1. Correct error in part number explanation; 2. Update mechanical drawing; 3. Update ripple, switching frequency, OVP, FIT, weight; 4. Add efficiency data, TD, NR, TR, Startup&shutdown, PG waveforms.	XF JIANG
2009-05-05	D	1, Add ripple and noise (p-p) under worst case. 2, Add efficiency curve of 1.35V output. 3, Add pin description. 4, Update Turn on/off voltage Threshold.	XF JIANG
2009-05-15	E	1. Add P/N VRP3-90E2A0; 2. Adjust output voltage range; 3. Update set point, efficiency, trim, FIT.	XF JIANG
2010-03-30	F	1. Remove "Preliminary", add product picture; 2. Input spec: 1)Update turn on/off voltage; 3. Output spec: 1)Update output voltage setpoint of VRP3-90E1A0; 2) output current limit; 3) turn on delay time and rise time; 4) output capacitance; 5) transient response setting time. 4. General spec: 1)Update switching frequency; 2)OTP; 3)product weight. 5. Update efficiency curve, thermal derating curves, Trim, UVLO, mechanical top and bottom view.	YF SUN
2010-08-12	G	Add the diagram of IMON	YF SUN

RoHS Compliance

Complies with the European Directive 2002/95/EC, calling for the elimination of lead and other hazardous substances from electronic products.



©2010 Bel Fuse Inc. Specifications subject to change without notice. 081210

14

CORPORATE

Bel Fuse Inc.
206 Van Vorst Street
Jersey City, NJ 07302
Tel 201-432-0463
Fax 201-432-9542
www.belfuse.com

FAR EAST

Bel Fuse Ltd.
8F/ 8 Luk Hop Street
San Po Kong
Kowloon, Hong Kong
Tel 852-2328-5515
Fax 852-2352-3706
www.belfuse.com

EUROPE

Bel Fuse Europe Ltd.
Preston Technology Management Centre
Marsh Lane, Suite G7, Preston
Lancashire, PR1 8UD, U.K.
Tel 44-1772-556601
Fax 44-1772-888366
www.belfuse.com