

8-bit Proprietary Microcontroller

CMOS

F²MC-8L MB89850R Series

MB89855R/P857/W857

■ DESCRIPTION

The MB89850R series has been developed as a general-purpose version of the F²MC*-8L family consisting of proprietary 8-bit, single-chip microcontrollers.

In addition to the F²MC-8L CPU core which can operate at low voltage but at high speed, the microcontrollers contain a variety of peripheral functions such as a timer unit, PWM timers, a UART, a serial interface, a 10-bit A/D converter, and an external interrupt.

The MB89850R series is applicable to a wide range of applications from consumer products to industrial equipment, including portable devices.

*: F²MC stands for FUJITSU Flexible Microcontroller.

■ FEATURES

- Various package options
SDIP package (64 pins)/QFP package (64 pins)
- High-speed processing at low voltage
Minimum execution time: 0.4 μ s/3.5 V, 0.8 μ s/2.7 V

(Continued)

■ PACKAGE

64-pin Plastic SH-DIP

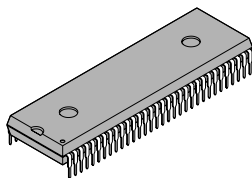

(DIP-64P-M01)

64-pin Plastic QFP

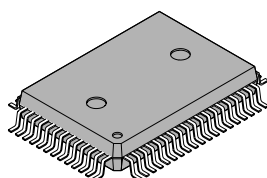

(FPT-64P-M06)

64-pin Ceramic SH-DIP

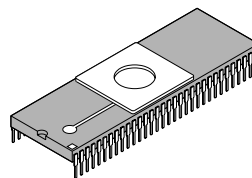

(DIP-64C-A06)

64-pin Ceramic QFP

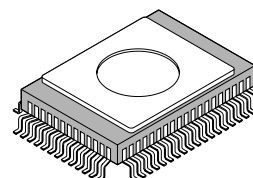

(FPT-64C-A02)

MB89850R Series

(Continued)

- F²MC-8L family CPU core

Instruction set optimized for controllers

Multiplication and division instructions
16-bit arithmetic operations
Test and branch instructions
Bit manipulation instructions, etc.

- 8-bit PWM timers: 2 channels
Also usable as a reload timer
- UART
Full-duplex double buffer
Synchronous and asynchronous data transfer
- 8-bit serial I/O
Switchable transfer direction allows communication with various equipment.
- 10-bit A/D converter
Conversion time: 13.2 μ s
Activation by an external input or a timer unit capable
- External interrupt: 4 channels
Four channels are independent and capable of wake-up from low-power consumption modes (with an edge detection function).
- Low-power consumption modes
Stop mode (Oscillation stops to minimize the current consumption.)
Sleep mode (The CPU stops to reduce the current consumption to approx. 1/3 of normal.)
- Bus interface functions
Including hold and ready functions
- Timer unit
Outputs non-overlap three-phase waveforms to control an AC inverter motor.
Also usable as a PWM timer (4 channels)

MB89850R Series

■ PRODUCT LINEUP

Part number Parameter	MB89855R	MB89P857 MB89W857
Classification	Mass production products (mask ROM products)	One-time PROM products/EPROM products, also used for evaluation
ROM size	16 K × 8 bits (internal mask ROM)	32 K × 8 bits (internal PROM, programming with general-purpose EPROM programmer)
RAM size	512 × 8 bits	1 K × 8 bits
CPU functions	Number of instructions: 136 Instruction bit length: 8 bits Instruction length: 1 to 3 bytes Data bit length: 1, 8, 16 bits Minimum execution time: 0.4 μs/10 MHz Interrupt processing time: 3.6 μs/10 MHz	
Ports	Input ports: 5 (All also serve as peripherals) Output ports (N-ch open drain): 8 (All also serve as peripherals) Output ports (CMOS): 8 (All also serve as bus control pins) I/O ports (CMOS): 32 (All also serve as bus pins or peripherals) Total: 53	
Timer unit	10-bit up/down count timer × 1 Compare registers with buffer × 4 Compare timer unit clear register with buffer × 1 Zero detection pin control 4 output channels Non-overlap three-phase waveform output Independent three-phase dead-time timer	
8-bit PWM timer 1, 8-bit PWM timer 2	8-bit reload timer operation (toggled output capable, operating clock cycle: 0.4 μs to 25.6 μs) 8-bit resolution PWM operation (conversion cycle: 102 μs to 6.528 ms)	
UART	8 bits Clock synchronous/asynchronous data transfer capable	
8-bit serial I/O	8 bits LSB first/MSB first selectability One clock selectable from four transfer clocks (one external shift clock, three internal shift clocks: 0.8 μs, 3.2 μs, 12.8 μs)	
10-bit A/D converter	10-bit resolution × 8 channels A/D conversion time: 13.2 μs Continuous activation by a compare channel 0 in timer unit or an external activation capable	
External interrupt	4 independent channels (edge selection, interrupt vector, source flag) Rising edge/falling edge selectability. Used also for wake-up from stop/sleep mode. (Edge detection is also permitted in stop mode.)	
Standby modes	Sleep mode, stop mode	
Process	CMOS	
Operating voltage*	2.7 V to 6.0 V	2.7 V to 5.5 V

* : Varies with conditions such as the operating frequency. (See section “■ Electrical Characteristics.”)

MB89850R Series

■ PACKAGE AND CORRESPONDING PRODUCTS

Package	MB89855R	MB89P857	MB89W857
DIP-64P-M01	○	○	×
DIP-64C-A06	×	×	○
FPT-64P-M06	○	○	×
FPT-64C-A02	×	×	○

○ : Available × : Not available

Note: For more information about each package, see section “■ Package Dimensions.”

■ DIFFERENCES AMONG PRODUCTS

1. Memory Size

Before evaluating using the OTPROM (one-time PROM) products (also used for evaluation), verify its differences from the product that will actually be used.

Take particular care on the following point:

- The stack area, etc., is set at the upper limit of the RAM.

2. Current Consumption

When operated at low speed, the product with an OTPROM or an EPROM will consume more current than the product with a mask ROM.

However, the current consumption in sleep/stop modes is the same.

3. Mask Options

In the MB89P857/W857, no option can be set.

Before using options check section “■ Mask Options.”

Take particular care on the following point:

- A pull-up resistor can be set for P00 to P07, P10 to P17 and P20 to P27 only at single-chip mode.

■ PIN ASSIGNMENT

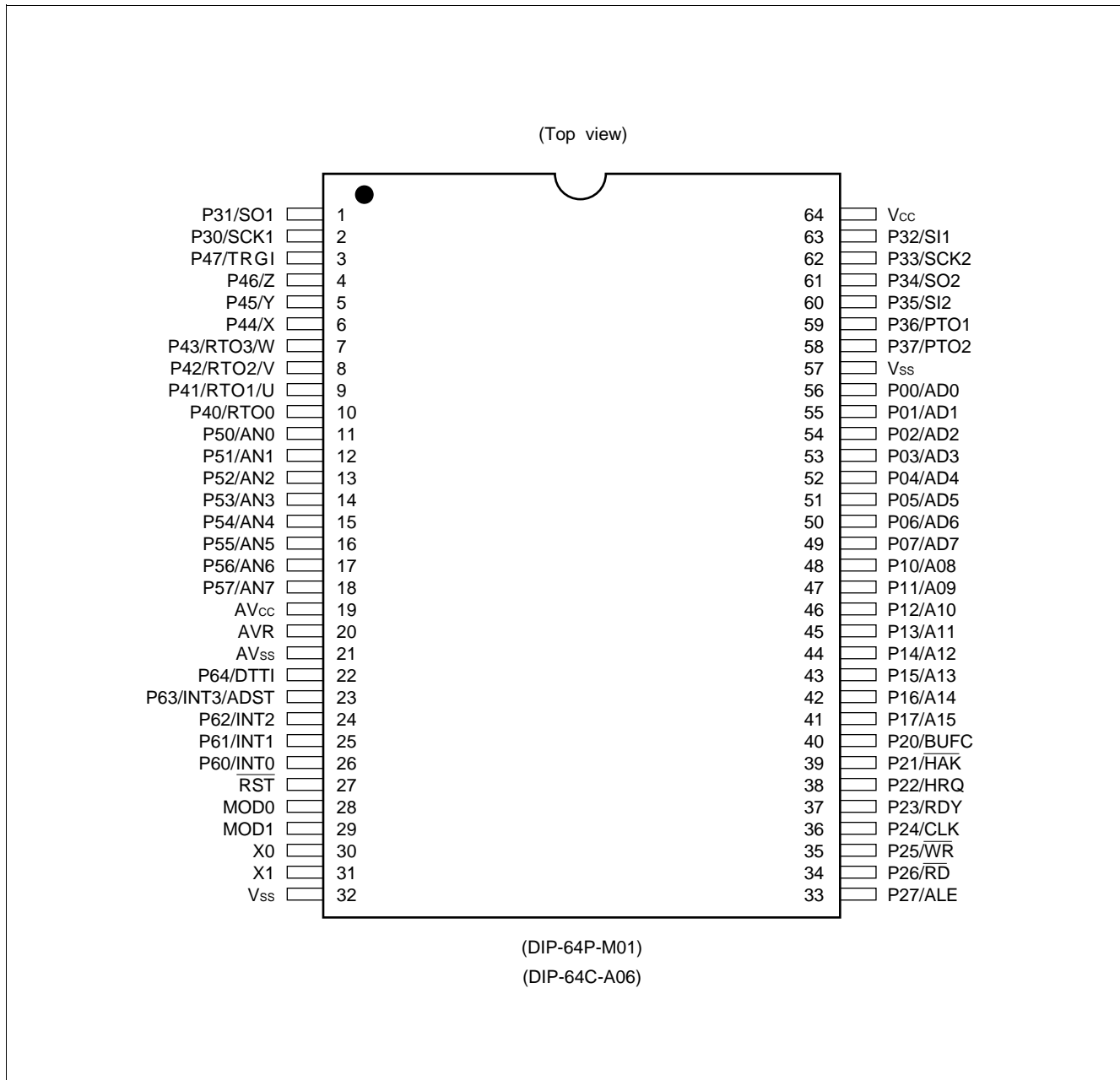

MB89850R Series

(Top view)

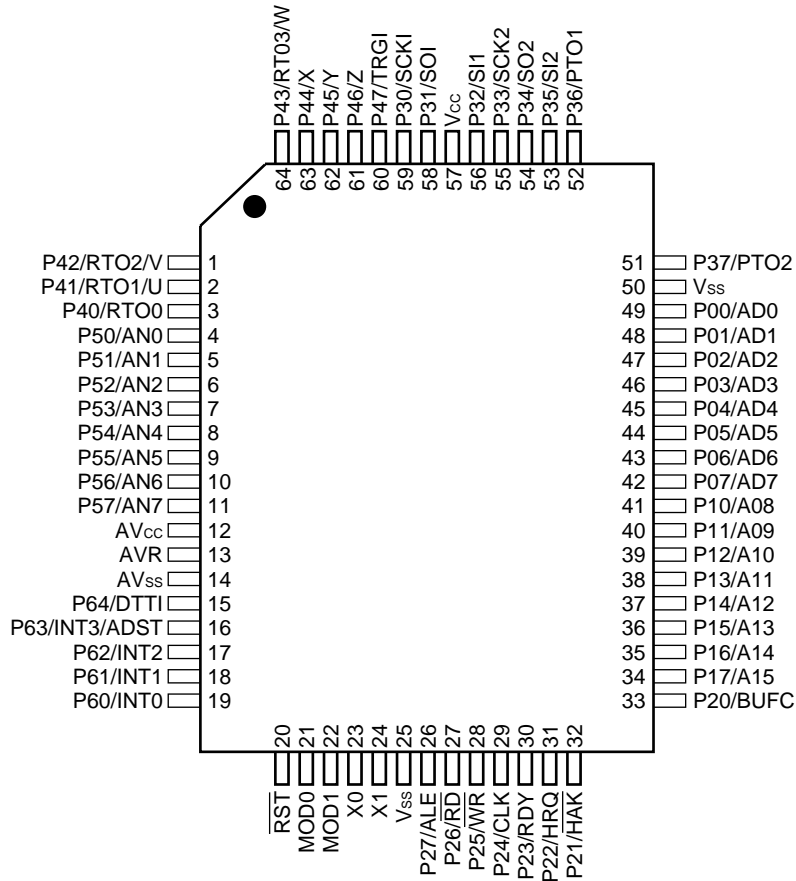

(FPT-64P-M06)
(FPT-64C-A02)

■ PIN DESCRIPTION

Pin no.		Pin name	Circuit type	Function
SH-DIP*1	QFP*2			
30	23	X0	A	Crystal oscillator pins (10 MHz)
31	24	X1		
28	21	MOD0	B	Operating mode selection pins Connect directly to V _{CC} or V _{SS} .
29	22	MOD1		
27	20	$\overline{\text{RST}}$	C	Reset I/O pin This pin is an N-ch open-drain output type with a pull-up resistor, and a hysteresis input type. "L" is output from this pin by an internal reset source. The internal circuit is initialized by the input of "L".
56 to 49	49 to 42	P00/AD0 to P07/AD7	D	General-purpose I/O ports When an external bus is used, these ports function as multiplex pins of lower address output and data I/O.
48 to 41	41 to 34	P10/A08 to P17/A15	D	General-purpose I/O ports When an external bus is used, these ports function as upper address output.
40	33	P20/BUFC	F	General-purpose output port When an external bus is used, this port can also be used as a buffer control output.
39	32	P21/ $\overline{\text{HAK}}$	F	General-purpose output port When an external bus is used, this port can also be used as a hold acknowledge output.
38	31	P22/HRQ	D	General-purpose output port When an external bus is used, this port can also be used as a hold request input.
37	30	P23/RDY	D	General-purpose output port When an external bus is used, this port functions as a ready input.
36	29	P24/CLK	F	General-purpose output port When an external bus is used, this port functions as a clock output.
35	28	P25/ $\overline{\text{WR}}$	F	General-purpose output port When an external bus is used, this port functions as a write signal output.
34	27	P26/ $\overline{\text{RD}}$	F	General-purpose output port When an external bus is used, this port functions as a read signal output.
33	26	P27/ALE	F	General-purpose output port When an external bus is used, this port functions as an address latch signal output.
2	59	P30/SCK1	E	General-purpose I/O port Also serves as the clock I/O for the UART. This port is a hysteresis input type.

*1: DIP-64P-M01, DIP-64C-A06

*2: FPT-64P-M06, FPT-64C-A02

(Continued)

MB89850R Series

(Continued)

Pin no.		Pin name	Circuit type	Function
SH-DIP*1	QFP*2			
1	58	P31/SO1	E	General-purpose I/O port Also serves as the data output for the UART. This port is a hysteresis input type.
63	56	P32/SI1	E	General-purpose I/O port Also serves as the data input for the UART. This port is a hysteresis input type.
62	55	P33/SCK2	E	General-purpose I/O port Also serves as the clock I/O for the 8-bit serial I/O. This port is a hysteresis input type.
61	54	P34/SO2	E	General-purpose I/O port Also serves as the data output for the 8-bit serial I/O. This port is a hysteresis input type.
60	53	P35/SI2	E	General-purpose I/O port Also serves as the data input for the 8-bit serial I/O. This port is a hysteresis input type.
59	52	P36/PTO1	E	General-purpose I/O port Also serves as the pulse output for the 8-bit PWM timer 1. This port is a hysteresis input type.
58	51	P37/PTO2	E	General-purpose I/O port Also serves as the pulse output for the 8-bit PWM timer 2. This port is a hysteresis input type.
10	3	P40/RTO0	E	General-purpose I/O port Also serves as the pulse output for the timer unit. This port is a hysteresis input type.
9, 8, 7	2, 1, 64	P41/RTO1/U, P42/RTO2/V, P43/RTO3/W	E	General-purpose I/O ports Also serve as the pulse output or non-overlap three-phase waveform output for the timer unit. These ports are a hysteresis input type.
6, 5, 4	63, 62, 61	P44/X, P45/Y, P46/Z	E	General-purpose I/O ports Also serve as a non-overlap three-phase waveform output. These ports are a hysteresis input type.
3	60	P47/TRGI	E	General-purpose I/O port Also serves as the trigger input for the timer unit. This port is a hysteresis input type.
11 to 18	4 to 11	P50/AN0 to P57/AN7	G	N-ch open-drain output ports Also serve as the analog input for the A/D converter.
26 to 24	19 to 17	P60/INT0 to P62/INT2	H	General-purpose input ports Also serve as an external interrupt input. These ports are a hysteresis input type.
23	16	P63/INT3/ ADST	H	General-purpose input port Also serves as an external interrupt input and as the activation trigger input for the A/D converter. This port is a hysteresis input type.

*1: DIP-64P-M01, DIP-64C-A06

*2: FPT-64P-M06, FPT-64C-A02

(Continued)

MB89850R Series

(Continued)

Pin no.		Pin name	Circuit type	Function
SH-DIP*1	QFP*2			
22	15	P64/DTTI	H	General-purpose input port Also serves as a dead-time timer disable input. This port is a hysteresis input type. DTTI input is with a noise canceller.
64	57	V _{CC}	—	Power supply pin
32, 57	25, 50	V _{SS}	—	Power supply (GND) pins
19	12	AV _{CC}	—	A/D converter power supply pin
20	13	AVR	—	A/D converter reference voltage input pin
21	14	AV _{SS}	—	A/D converter power supply (GND) pin Use this pin at the same voltage as V _{SS} .

*1: DIP-64P-M01, DIP-64C-A06

*2: FPT-64P-M06, FPT-64C-A02

MB89850R Series

■ I/O CIRCUIT TYPE

Type	Circuit	Remarks
A	<p>Standby control signal</p>	<ul style="list-style-type: none"> • At an oscillation feedback resistor of approximately 1 MΩ/5.0 V
B		
C		<ul style="list-style-type: none"> • At an output pull-up resistor (P-ch) of approximately 50 kΩ/5.0 V • Hysteresis input
D		<ul style="list-style-type: none"> • CMOS output • CMOS input • Pull-up resistor optional (Mask ROM products) • At a pull-up resistor of approximately 50 kΩ/5.0 V
E		<ul style="list-style-type: none"> • CMOS output • Hysteresis input • Pull-up resistor optional (Mask ROM products) • At a pull-up resistor of approximately 50 kΩ/5.0 V

(Continued)

MB89850R Series

(Continued)

Type	Circuit	Remarks
F		<ul style="list-style-type: none"> • CMOS output • Pull-up resistor optional (Mask ROM products) • At a pull-up resistor of approximately 50 kΩ/5.0 V
G		<ul style="list-style-type: none"> • N-ch open-drain output • Analog input
H		<ul style="list-style-type: none"> • Hysteresis input • Pull-up resistor optional (Mask ROM products) • At a pull-up resistor of approximately 50 kΩ/5.0 V

■ HANDLING DEVICES

1. Preventing Latchup

Latchup may occur on CMOS ICs if voltage higher than V_{CC} or lower than V_{SS} is applied to input and output pins other than medium- and high-voltage pins or if higher than the voltage which shows on “1. Absolute Maximum Ratings” in section “■ Electrical Characteristics” is applied between V_{CC} and V_{SS} .

When latchup occurs, power supply current increases rapidly and might thermally damage elements. When using, take great care not to exceed the absolute maximum ratings.

Also, take care to prevent the analog power supply (AV_{CC} and AVR) and analog input from exceeding the digital power supply (V_{CC}) when the analog system power supply is turned on and off.

2. Treatment of Unused Input Pins

Leaving unused input pins open could cause malfunctions. They should be connected to a pull-up or pull-down resistor.

3. Treatment of Power Supply Pins on Microcontrollers with A/D and D/A Converters

Connect to be $AV_{CC} = DAVC = V_{CC}$ and $AV_{SS} = AVR = V_{SS}$ even if the A/D and D/A converters are not in use.

4. Treatment of N.C. Pin

Be sure to leave (internally connected) N.C. pin open.

5. Power Supply Voltage Fluctuations

Although V_{CC} power supply voltage is assured to operate within the rated range, a rapid fluctuation of the voltage could cause malfunctions, even if it occurs within the rated range. Stabilizing voltage supplied to the IC is therefore important. As stabilization guidelines, it is recommended to control power so that V_{CC} ripple fluctuations (P-P value) will be less than 10% of the standard V_{CC} value at the commercial frequency (50 to 60 Hz) and the transient fluctuation rate will be less than 0.1 V/ms at the time of a momentary fluctuation such as when power is switched.

6. Precautions when Using an External Clock

Even when an external clock is used, oscillation stabilization time is required for power-on reset (optional) and wake-up from stop mode.

■ PROGRAMMING TO THE EPROM ON THE MB89P857/W857

The MB89P857/W857 are an OTPROM version of the MB89850R series.

1. Features

- 32-Kbyte PROM on chip
- Equivalency to the MBM27C256A in EPROM mode (when programmed with the EPROM programmer)

2. Memory Space

Memory space in EPROM mode is diagrammed below.

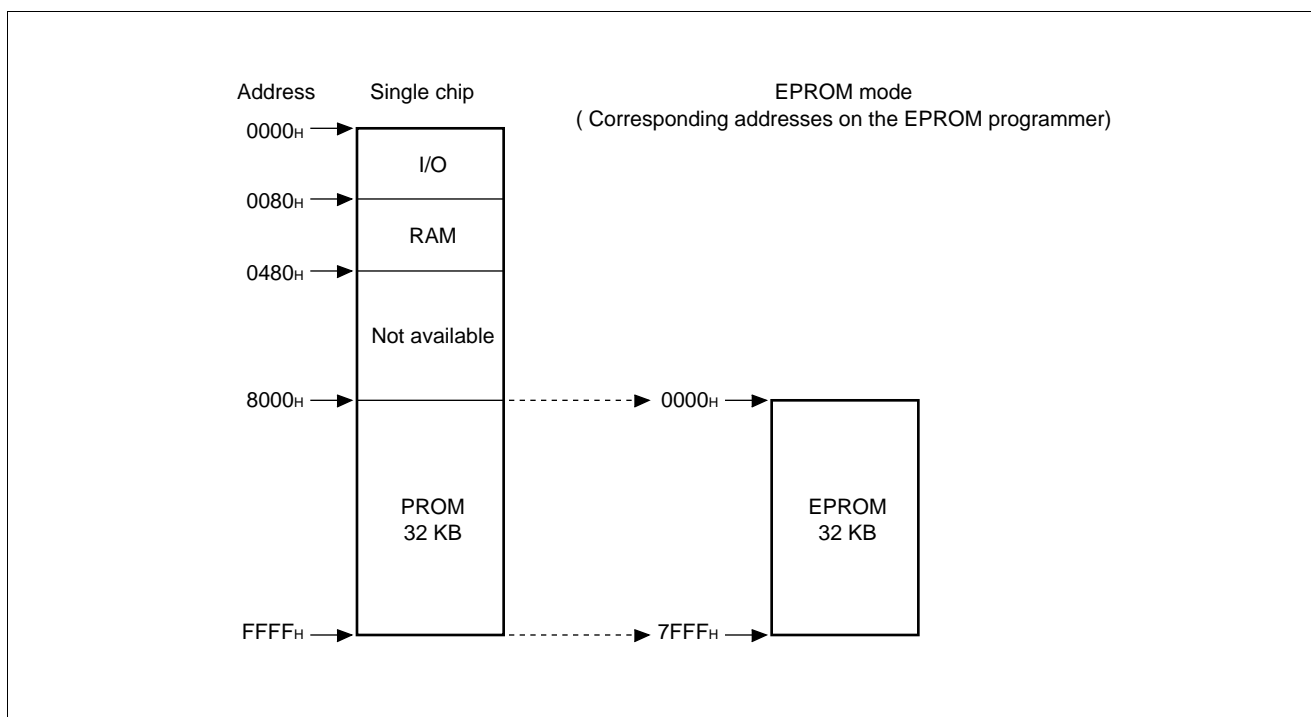

3. Programming to the EPROM

In EPROM mode, the MB89P857/W857 functions equivalent to the MBM27C256A. This allows the PROM to be programmed with a general-purpose EPROM programmer (the electronic signature mode cannot be used) by using the dedicated socket adapter.

• Programming procedure

- (1) Set the EPROM programmer to the MBM27C256A.
- (2) Load program data into the EPROM programmer at 0000H to 7FFFH (note that addresses 8000H to FFFFH while operating as a single chip assign to addresses 0000H to 7FFFH in EPROM mode.)
- (3) Program to 0000H to 7FFFH with the EPROM programmer.

MB89850R Series

4. Recommended Screening Conditions

High-temperature aging is recommended as the pre-assembly screening procedure for a product with a blanked OTPROM microcomputer program.

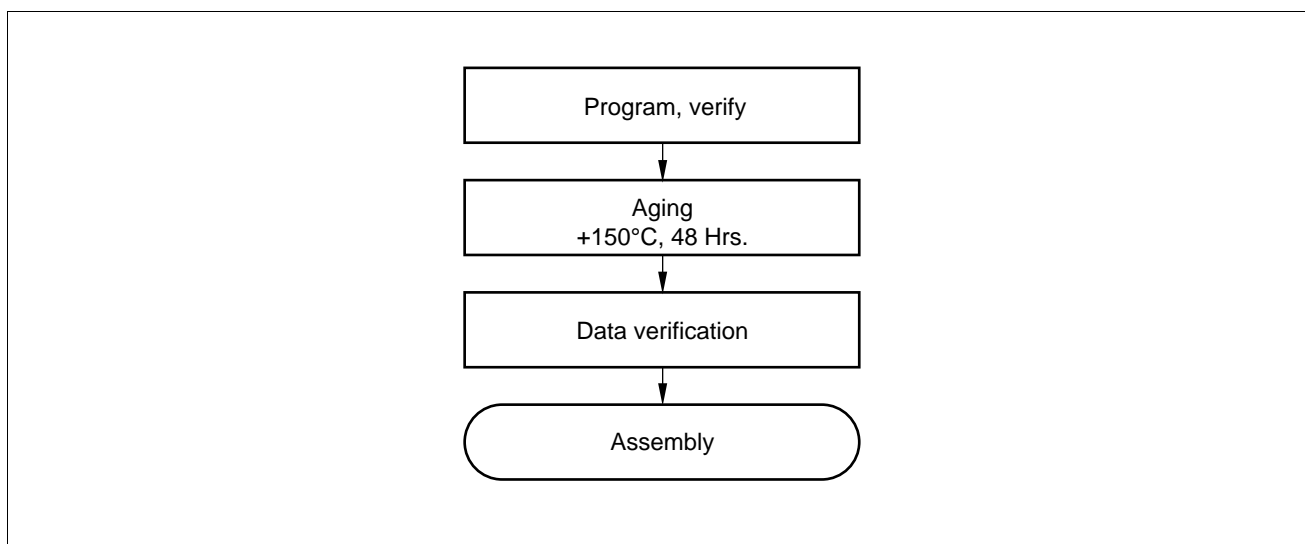

5. Programming Yield

All bits cannot be programmed at Fujitsu shipping test to a blanked OTPROM microcomputer, due to its nature. For this reason, a programming yield of 100% cannot be assured at all times.

6. Erasure

In order to clear all locations of their programmed contents, it is necessary to expose the internal EPROM to an ultraviolet light source. A dosage of 10 W-seconds/cm² is required to completely erase an internal EPROM. This dosage can be obtained by exposure to an ultraviolet lamp (wavelength of 2537 Angstroms (Å)) with intensity of 12000 μW/cm² for 15 to 21 minutes. The internal EPROM should be about one inch from the source and all filters should be removed from the UV light source prior to erasure.

It is important to note that the internal EPROM and similar devices, will erase with light sources having wavelengths shorter than 4000 Å. Although erasure time will be much longer than with UV source at 2537 Å, nevertheless the exposure to fluorescent light and sunlight will eventually erase the internal EPROM, and exposure to them should be prevented to realize maximum system reliability. If used in such an environment, the package windows should be covered by an opaque label or substance.

7. EPROM Programmer Socket Adapter

Package	Compatible socket adapter
DIP-64P-M01	ROM-64SD-28DP-8L*
FPT-64P-M06	ROM-64QF-28DP-8L
FPT-64P-A02	ROM-64QF-28DP-8L5

* : Connect the adapter jumper pin to V_{SS} when using.

Inquiry: Sun Hayato Co., Ltd.: Fax 81-3-5396-9106

■ BLOCK DIAGRAM

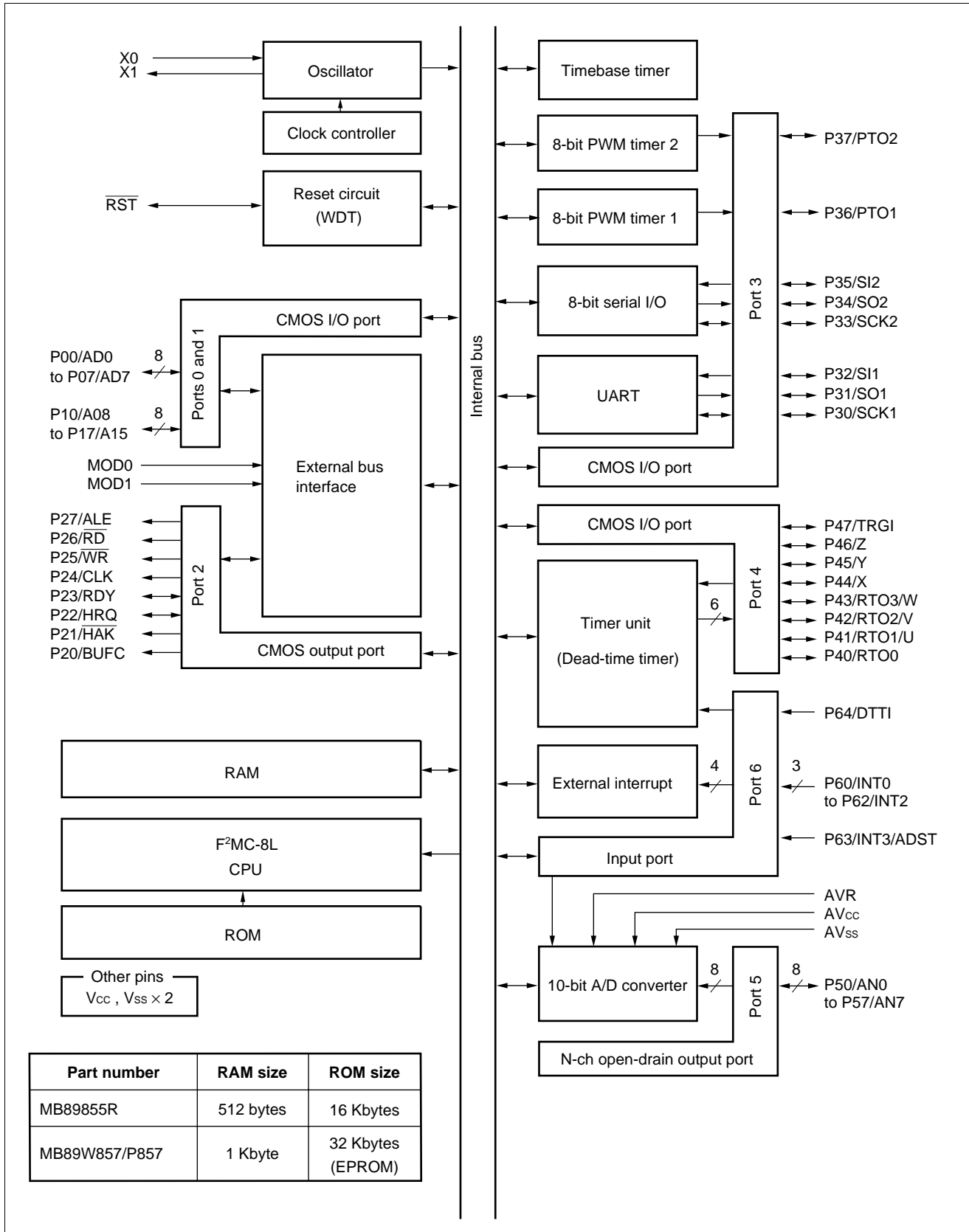

MB89850R Series

■ CPU CORE

1. Memory Space

The microcontrollers of the MB89850R series offer a memory space of 64 Kbytes for storing all of I/O, data, and program areas. The I/O area is located at the lowest address. The data area is provided immediately above the I/O area. The data area can be divided into register, stack, and direct areas according to the application. The program area is located at exactly the opposite end, that is, near the highest address. Provide the tables of interrupt reset vectors and vector call instructions toward the highest address within the program area. The memory space of the MB89860/850 series is structured as illustrated below.

• Memory Space

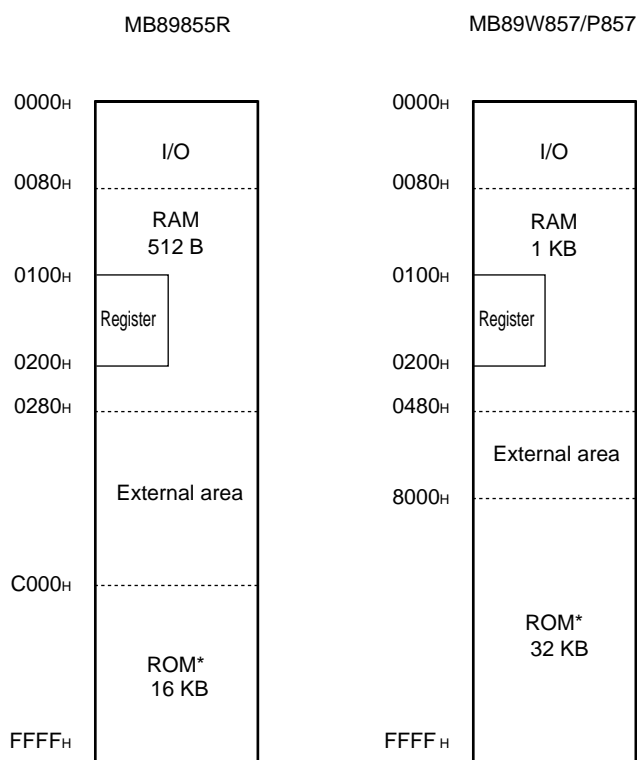

*: The ROM area is an external area depending on the mode.

2. Registers

The F²MC-8L family has two types of registers; dedicated registers in the CPU and general-purpose registers in the memory. The following dedicated registers are provided:

- Program counter (PC): A 16-bit register for indicating instruction storage positions
- Accumulator (A): A 16-bit temporary register for storing arithmetic operations, etc. When the instruction is an 8-bit data processing instruction, the lower byte is used.
- Temporary accumulator (T): A 16-bit register which performs arithmetic operations with the accumulator
When the instruction is an 8-bit data processing instruction, the lower byte is used.
- Index register (IX): A 16-bit register for index modification
- Extra pointer (EP): A 16-bit pointer for indicating a memory address
- Stack pointer (SP): A 16-bit register for indicating a stack area
- Program status (PS): A 16-bit register for storing a register pointer, a condition code

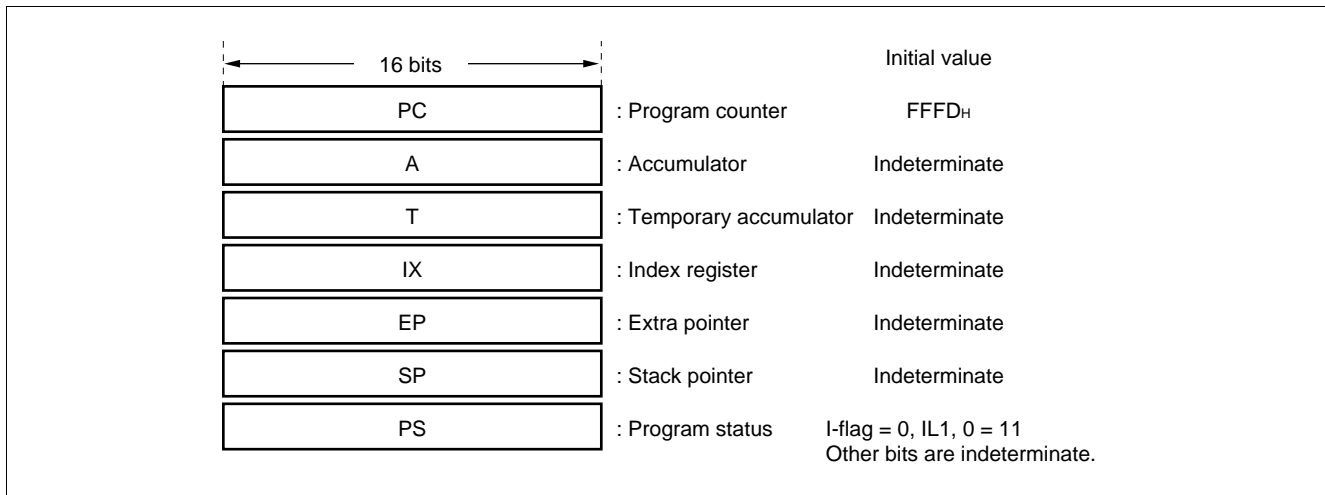

The PS can further be divided into higher 8 bits for use as a register bank pointer (RP) and the lower 8 bits for use as a condition code register (CCR). (See the diagram below.)

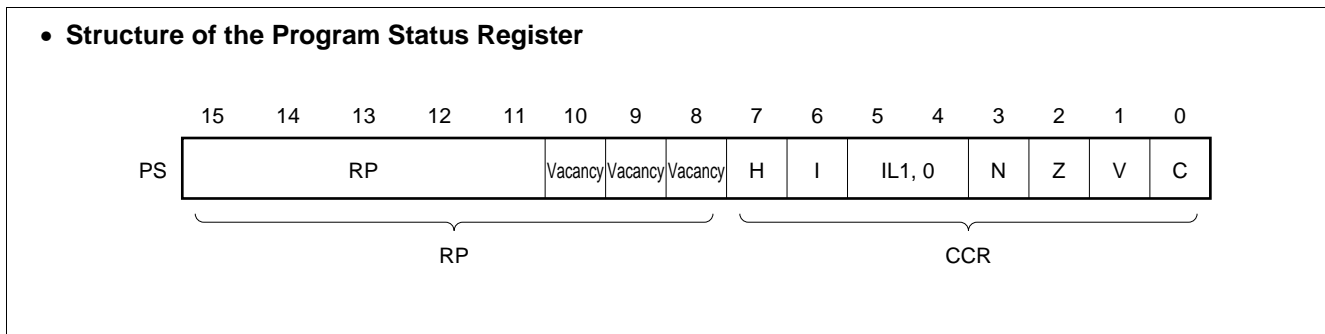

MB89850R Series

The RP indicates the address of the register bank currently in use. The relationship between the pointer contents and the actual address is based on the conversion rule illustrated below.

• **Rule for Conversion of Actual Addresses of the General-purpose Register Area**



The CCR consists of bits indicating the results of arithmetic operations and the contents of transfer data and bits for control of CPU operations at the time of an interrupt.

H-flag: Set when a carry or a borrow from bit 3 to bit 4 occurs as a result of an arithmetic operation. Cleared otherwise. This flag is for decimal adjustment instructions.

I-flag: Interrupt is allowed when this flag is set to 1. Interrupt is prohibited when the flag is set to 0. Set to 0 when reset.

IL1, 0: Indicates the level of the interrupt currently allowed. Processes an interrupt only if its request level is higher than the value indicated by this bit.

IL1	IL0	Interrupt level	High-low
0	0	1	<div style="text-align: center;">High</div> <div style="text-align: center;">↑</div> <div style="text-align: center;">↓</div> <div style="text-align: center;">Low = no interrupt</div>
0	1		
1	0	2	
1	1	3	

N-flag: Set if the MSB is set to 1 as the result of an arithmetic operation. Cleared when the bit is set to 0.

Z-flag: Set when an arithmetic operation results in 0. Cleared otherwise.

V-flag: Set if the complement on 2 overflows as a result of an arithmetic operation. Reset if the overflow does not occur.

C-flag: Set when a carry or a borrow from bit 7 occurs as a result of an arithmetic operation. Cleared otherwise. Set to the shift-out value in the case of a shift instruction.

The following general-purpose registers are provided:

General-purpose registers: An 8-bit register for storing data

The general-purpose registers are 8 bits and located in the register banks of the memory. One bank contains eight registers and up to a total of 32 banks can be used on the MB89850R series. The bank currently in use is indicated by the register bank pointer (RP).

Note: The number of register banks that can be used varies with the RAM size.

- **Register Bank Configuration**

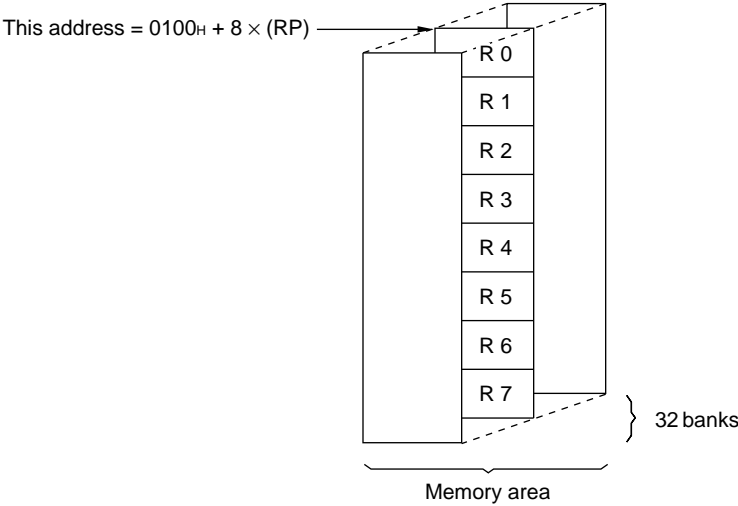

MB89850R Series

■ I/O MAP

Address	Read/write	Register name	Register description
00 _H	(R/W)	PDR0	Port 0 data register
01 _H	(W)	DDR0	Port 0 data direction register
02 _H	(R/W)	PDR1	Port 1 data register
03 _H	(W)	DDR1	Port 1 data direction register
04 _H	(R/W)	PDR2	Port 2 data register
05 _H	(W)	BCTR	External bus pin control register
06 _H			Vacancy
07 _H			Vacancy
08 _H	(R/W)	STBC	Standby control register
09 _H	(W)	WDTC	Watchdog timer control register
0A _H	(R/W)	TBTC	Timebase timer control register
0B _H			Vacancy
0C _H	(R/W)	PDR3	Port 3 data register
0D _H	(W)	DDR3	Port 3 data direction register
0E _H	(R/W)	PDR4	Port 4 data register
0F _H	(W)	DDR4	Port 4 data direction register
10 _H	(R/W)	PDR5	Port 5 data register
11 _H			Vacancy
12 _H	(R)	PDR6	Port 6 data register
13 _H			Vacancy
14 _H	(R/W)	PDR7	Port 7 data register
15 _H			Vacancy
16 _H	(R/W)	PDR8	Port 8 data register
17 _H to 1B _H			Vacancy
1C _H	(R/W)	CTR1	PWM control register 1
1D _H	(W)	CMR1	PWM compare register 1
1E _H	(R/W)	CTR2	PWM control register 2
1F _H	(W)	CMR2	PWM compare register 2
20 _H	(R/W)	SMC	UART serial mode control register
21 _H	(R/W)	SRC	UART serial rate control register
22 _H	(R/W)	SSD	UART serial status/data register
23 _H	(R/W)	SIDR/SODR	UART serial data register
24 _H	(R/W)	SMR	Serial mode register
25 _H	(R/W)	SDR	Serial data register

(Continued)

(Continued)

Address	Read/write	Register name	Register description
26 _H	(R/W)	EIC1	External interrupt control register 1
27 _H	(R/W)	EIC2	External interrupt control register 2
28 _H	(R/W)	ADC1	A/D converter control register 1
29 _H	(R/W)	ADC2	A/D converter control register 2
2A _H	(R)	ADDH	A/D converter data register (H)
2B _H	(R)	ADDL	A/D converter data register (L)
2C _H			Vacancy
2D _H	(W)	ZOCTR	Zero detection output control register
2E _H	(W)	CLRBRH	Compare clear buffer register (H)
2F _H	(W)	CLRBRL	Compare clear buffer register (L)
30 _H	(R/W)	TCSR	Timer control status register
31 _H	(R/W)	CICR	Compare interrupt control register
32 _H	(R/W)	TMCR	Timer mode control register
33 _H	(R/W)	COER	Compare/port selection register
34 _H	(R/W)	CMCR	Compare buffer mode control register
35 _H	(R/W)	DTCR	Dead-time timer control register
36 _H	(W)	DTSR	Dead-time setting register
37 _H	(R/W)	OCTBR	Output control buffer register
38 _H	(W)	OCPBR0H	Output compare buffer register 0 (H)
39 _H	(W)	OCPBR0L	Output compare buffer register 0 (L)
3A _H	(W)	OCPBR1H	Output compare buffer register 1 (H)
3B _H	(W)	OCPBR1L	Output compare buffer register 1 (L)
3C _H	(W)	OCPBR2H	Output compare buffer register 2 (H)
3D _H	(W)	OCPBR2L	Output compare buffer register 2 (L)
3E _H	(W)	OCPBR3H	Output compare buffer register 3 (H)
3F _H	(W)	OCPBR3L	Output compare buffer register 3 (L)
40 _H to 7B _H			Vacancy
7C _H	(W)	ILR1	Interrupt level setting register 1
7D _H	(W)	ILR2	Interrupt level setting register 2
7E _H	(W)	ILR3	Interrupt level setting register 3
7F _H			Vacancy

Notes: • Do not use vacancies.

- When a read-modify-write instruction (such as bit set) is used to access a write-only register or a register containing a write-only bit, a bit designated by the instruction will have a predetermined value. However, a write-only bit included, if any, in bits not defined by the instruction will cause a malfunction. So no access to the register should be tried with any read-modify-write instruction.

MB89850R Series

■ ELECTRICAL CHARACTERISTICS

1. Absolute Maximum Ratings

($AV_{SS} = V_{SS} = 0.0\text{ V}$)

Parameter	Symbol	Value		Unit	Remarks
		Min.	Max.		
Power supply voltage	V_{CC} AV_{CC}	$V_{SS} - 0.3$	$V_{SS} + 7.0$	V	*
A/D converter reference input voltage	AVR	$V_{SS} - 0.3$	$V_{SS} + 7.0$	V	AVR must not exceed $AV_{CC} + 0.3\text{ V}$.
Program voltage	V_{PP}	$V_{SS} - 0.3$	13.0	V	MOD1 pins of MB89P857/ W857
Input voltage	V_I	$V_{SS} - 0.3$	$V_{CC} + 0.3$	V	
Output voltage	V_O	$V_{SS} - 0.3$	$V_{SS} + 0.3$	V	
“L” level maximum output current	I_{OL}	—	20	mA	
“L” level average output current	I_{OLAV1}	—	4	mA	P00 to P07, P10 to P17, P20 to P27, P30 to P37, P50 to P57
	I_{OLAV2}	—	15	mA	P40 to P47
“L” level total average output current	ΣI_{OLAV1}	—	30	mA	P00 to P07, P10 to P17, P20 to P27, P30 to P37, P50 to P57
	ΣI_{OLAV2}	—	50	mA	P40 to P47
“H” level maximum output current	I_{OH}	—	-20	mA	
“H” level average output current	I_{OHAV}	—	-4	mA	
“H” level total maximum output current	ΣI_{OH}	—	-20	mA	
Power consumption	P_D	—	300	mW	
Operating temperature	T_A	-40	+85	°C	
Storage temperature	T_{stg}	-55	+150	°C	

*: Use AV_{CC} and V_{CC} set at the same voltage.

Take care so that AV_{CC} does not exceed V_{CC} , such as when power is turned on.

WARNING: Permanent device damage may occur if the above “Absolute Maximum Ratings” are exceeded. Functional operation should be restricted to the conditions as detailed in the operational sections of this data sheet. Exposure to absolute maximum rating conditions for extended periods may affect device reliability.

2. Recommended Operating Conditions

($AV_{SS} = V_{SS} = 0.0\text{ V}$)

Parameter	Symbol	Value		Unit	Remarks
		Min.	Max.		
Power supply voltage	V_{CC} AV_{CC}	2.7*	6.0*	V	Normal operation assurance range* MB89855R
		2.7*	5.5*	V	Normal operation assurance range* MB89P857/W855
		1.5	6.0	V	Retains the RAM state in stop mode
A/D converter reference input voltage	AVR	0.0	AV_{CC}	V	
Operating temperature	T_A	-40	+85	°C	

*: These values vary with the operating frequency, instruction cycle, and analog assurance range. See Figure 1 and "5. A/D Converter Electrical Characteristics."

Note: Connect the MOD0 and MOD1 pins to V_{CC} or V_{SS} .

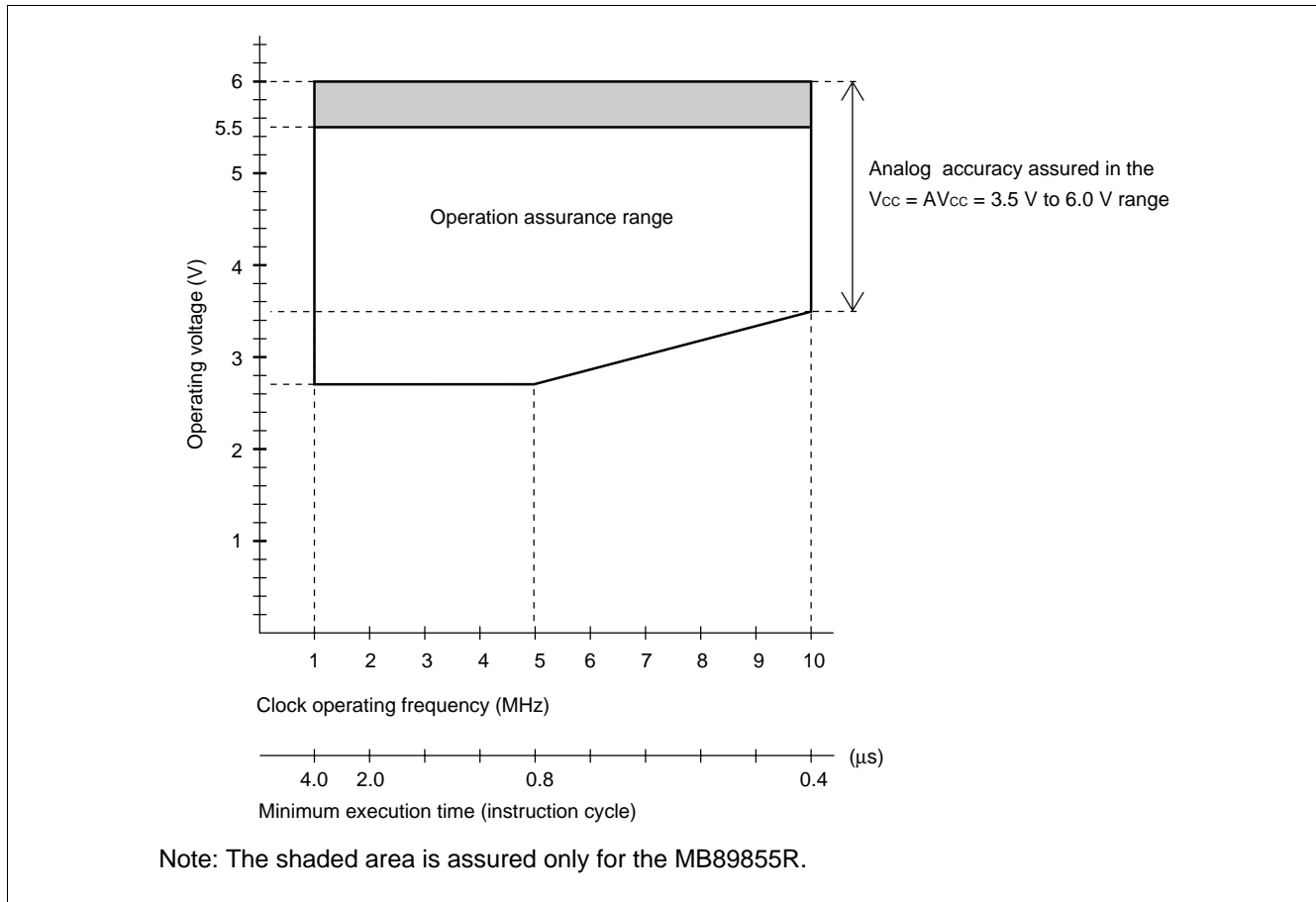

Figure 1 Operating Voltage vs. Clock Operating Frequency

MB89850R Series

3. DC Characteristics

($AV_{CC} = V_{CC} = +5.0\text{ V}$, $AV_{SS} = V_{SS} = 0.0\text{ V}$, $T_A = -40^\circ\text{C}$ to $+85^\circ\text{C}$)

Parameter	Symbol	Pin name	Condition	Value			Unit	Remarks
				Min.	Typ.	Max.		
“H” level input voltage	V_{IH}	P00 to P07, P10 to P17, P22, P23	—	$0.7 V_{CC}$	—	$V_{CC} + 0.3$	V	
	V_{IHS}	\overline{RST} , P30 to P37, P40 to P47, P60 to P64	—	$0.8 V_{CC}$	—	$V_{CC} + 0.3$	V	
“L” level input voltage	V_{IL}	P00 to P07, P10 to P17, P22, P23	—	$V_{SS} - 0.3$	—	$0.3 V_{CC}$	V	
	V_{ILS}	\overline{RST} , P30 to P37, P40 to P47, P60 to P64	—	$V_{SS} - 0.3$	—	$0.2 V_{CC}$	V	
“H” level output voltage	V_{OH}	P00 to P07, P10 to P17, P20 to P27, P30 to P37, P40 to P47	$I_{OH} = -2.0\text{ mA}$	2.4	—	—	V	
“L” level output voltage	V_{OL}	P00 to P07, P10 to P17, P20 to P27, P30 to P37, P50 to P57	$I_{OL} = +1.8\text{ mA}$	—	—	0.4	V	
	V_{OL2}	P40 to P47	$I_{OL} = +1.5\text{ mA}$	—	—	1.5	V	
Input leakage current	I_{LI1}	P00 to P07, P10 to P17, P20 to P27, P30 to P37, P40 to P47, P60 to P64, MOD0, MOD1	$0.0\text{ V} < V_I < V_{CC}$	—	—	± 5	μA	
Pull-up resistance	R_{PULL}	\overline{RST}	$V_I = 0.0\text{ V}$	25	50	100	k Ω	With pull-up resistor
Power supply current	I_{CC}	V_{CC}	$F_C = 10\text{ MHz}$ Normal operation mode (External clock)	—	15	18	mA	
	I_{CCS}		$F_C = 10\text{ MHz}$ Sleep mode (External clock)	—	6	8	mA	
	I_{CCH}		Stop mode $T_A = +25^\circ\text{C}$	—	—	10	μA	
	I_A	AV_{CC}	$F_C = 10\text{ MHz}$, when A/D conversion is activated	—	6	—	μA	
Input capacitance	C_{IN}	Other than AV_{CC} , AV_{SS} , V_{CC} , and V_{SS}	$f = 1\text{ MHz}$	—	10	—	pF	

4. AC Characteristics

(1) Reset Timing

($V_{CC} = +5.0\text{ V} \pm 10\%$, $A_{V_{SS}} = V_{SS} = 0.0\text{ V}$, $T_A = -40^\circ\text{C}$ to $+85^\circ\text{C}$)

Parameter	Symbol	Condition	Value		Unit	Remarks
			Min.	Max.		
$\overline{\text{RST}}$ "L" pulse width	t_{ZLZH}	—	16 t_{CYL}^*	—	ns	

* : t_{CYL} is the oscillation cycle ($1/F_C$) to input to the X0 pin.

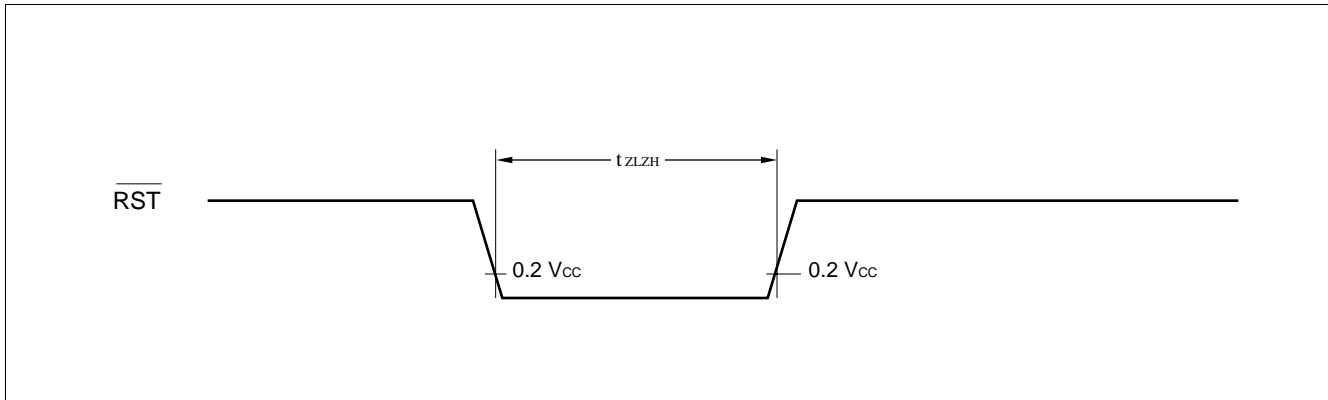

(2) Power-on Reset

($A_{V_{SS}} = V_{SS} = 0.0\text{ V}$, $T_A = -40^\circ\text{C}$ to $+85^\circ\text{C}$)

Parameter	Symbol	Condition	Value		Unit	Remarks
			Min.	Max.		
Power supply rising time	t_{R}	—	—	50	ms	Power-on reset function only
Power supply cut-off time	t_{OFF}		1	—	ms	Due to repeated operations

Note: Make sure that power supply rises within the selected oscillation stabilization time.

If power supply voltage needs to be varied in the course of operation, a smooth voltage rise is recommended.

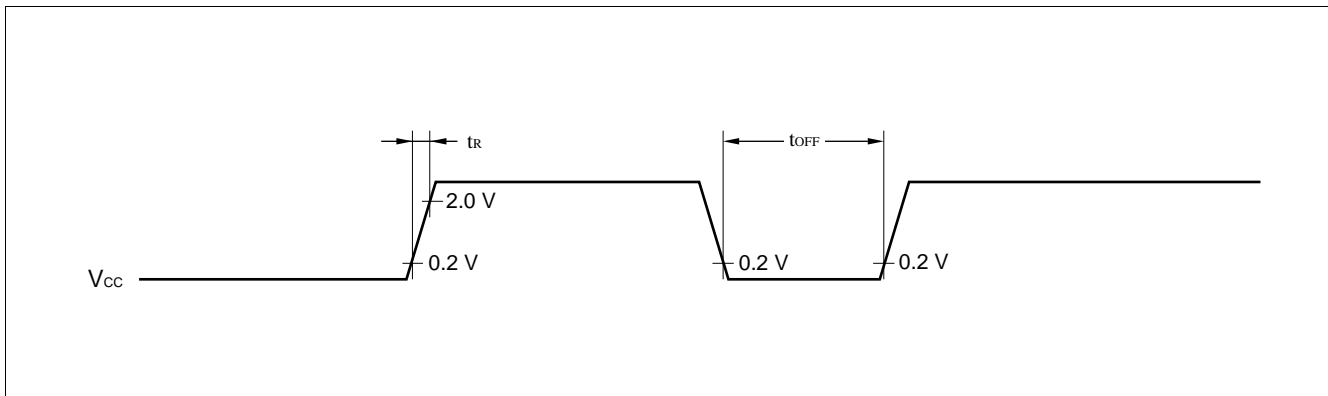

MB89850R Series

(3) Clock Timing

($V_{SS} = V_{SS} = 0.0\text{ V}$, $T_A = -40^\circ\text{C}$ to $+85^\circ\text{C}$)

Parameter	Symbol	Pin name	Condition	Value		Unit	Remarks
				Min.	Max.		
Clock frequency	F_C	X0, X1	—	1	10	MHz	
Clock cycle time	t_{XCYL}			100	1000	ns	
Input clock pulse width	P_{WH} P_{WL}	X0	—	20	—	ns	External clock
Input clock rising/falling time	t_{CR} t_{CF}			—	10	ns	External clock

• X0 and X1 Timing Conditions

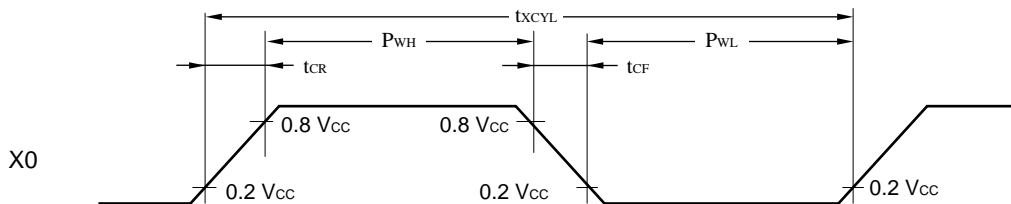

• Clock Conditions

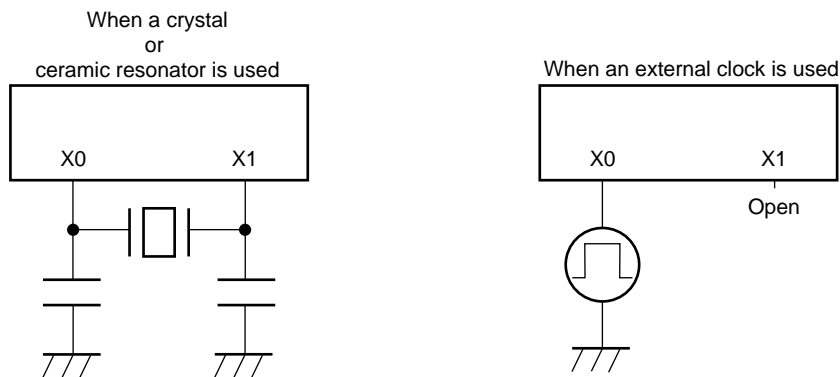

(4) Instruction Cycle

Parameter	Symbol	Value (typical)	Unit	Remarks
Instruction cycle (minimum execution time)	t_{inst}	$4/F_C$	μs	$t_{inst} = 0.4\ \mu\text{s}$ when operating at $F_C = 10\ \text{MHz}$

(5) Clock Output Timing

($V_{CC} = +5.0\text{ V} \pm 10\%$, $A_{V_{SS}} = V_{SS} = 0.0\text{ V}$, $T_A = -40^\circ\text{C}$ to $+85^\circ\text{C}$)

Parameter	Symbol	Pin name	Condition	Value		Unit	Remarks
				Min.	Max.		
Cycle time	t_{CYC}	CLK	Load condition: 50 pF	200	—	ns	$t_{CYL} \times 2$ at 10 MHz oscillation
CLK $\uparrow \rightarrow$ CLK \downarrow	t_{CHCL}			30	100	ns	Approx. $t_{CYC}/2$ at 10 MHz oscillation

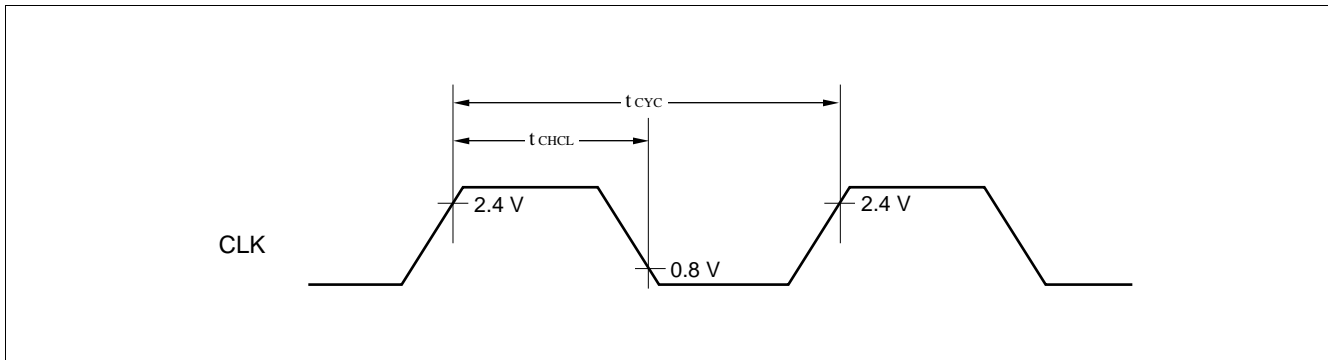

MB89850R Series

(6) Bus Read Timing

($V_{CC} = +5.0 V \pm 10\%$, $F_C = 10 \text{ MHz}$, $A_{VSS} = V_{SS} = 0.0 \text{ V}$, $T_A = -40^\circ\text{C}$ to $+85^\circ\text{C}$)

Parameter	Symbol	Pin name	Condition	Value (10 MHz)		Unit	Remarks
				Min.	Max.		
Valid address $\rightarrow \overline{\text{RD}} \downarrow$ time	t_{AVRL}	$\overline{\text{RD}}$, A15 to A08, AD7 to AD0	Load condition: 50 pF	$1/4 t_{\text{inst}}^* - 64 \text{ ns}$	—	ns	
$\overline{\text{RD}}$ pulse width	t_{RLRH}	$\overline{\text{RD}}$		$1/2 t_{\text{inst}}^* - 20 \text{ ns}$	—	ns	
Valid address \rightarrow data read time	t_{AVDV}	AD7 to AD0, A15 to A08		—	$1/2 t_{\text{inst}}^*$	ns	No wait
$\overline{\text{RD}} \downarrow \rightarrow$ data read time	t_{RLDV}	$\overline{\text{RD}}$, AD7 to AD0		—	$1/2 t_{\text{inst}}^* - 80 \text{ ns}$	ns	No wait
$\overline{\text{RD}} \uparrow \rightarrow$ data hold time	t_{RHDX}	AD7 to AD0, $\overline{\text{RD}}$		0	—	ns	
$\overline{\text{RD}} \uparrow \rightarrow$ ALE \uparrow time	t_{RHLH}	$\overline{\text{RD}}$, ALE		$1/4 t_{\text{inst}}^* - 40 \text{ ns}$	—	ns	
$\overline{\text{RD}} \uparrow \rightarrow$ address invalid time	t_{RHAX}	$\overline{\text{RD}}$, A15 to A08		$1/4 t_{\text{inst}}^* - 40 \text{ ns}$	—	ns	
$\overline{\text{RD}} \downarrow \rightarrow$ CLK \uparrow time	t_{RLCH}	$\overline{\text{RD}}$, CLK		$1/4 t_{\text{inst}}^* - 60 \text{ ns}$	—	ns	
CLK $\downarrow \rightarrow \overline{\text{RD}} \uparrow$ time	$t_{\text{CLR H}}$			0	—	ns	
$\overline{\text{RD}} \downarrow \rightarrow$ BUFC \downarrow time	t_{RLBL}	$\overline{\text{RD}}$, BUFC		-5	—	ns	
BUFC $\uparrow \rightarrow$ valid address time	t_{BHAV}	A15 to A08, AD7 to AD0, BUFC	5	—	ns		

* : For information on t_{inst} , see "(4) Instruction Cycle."

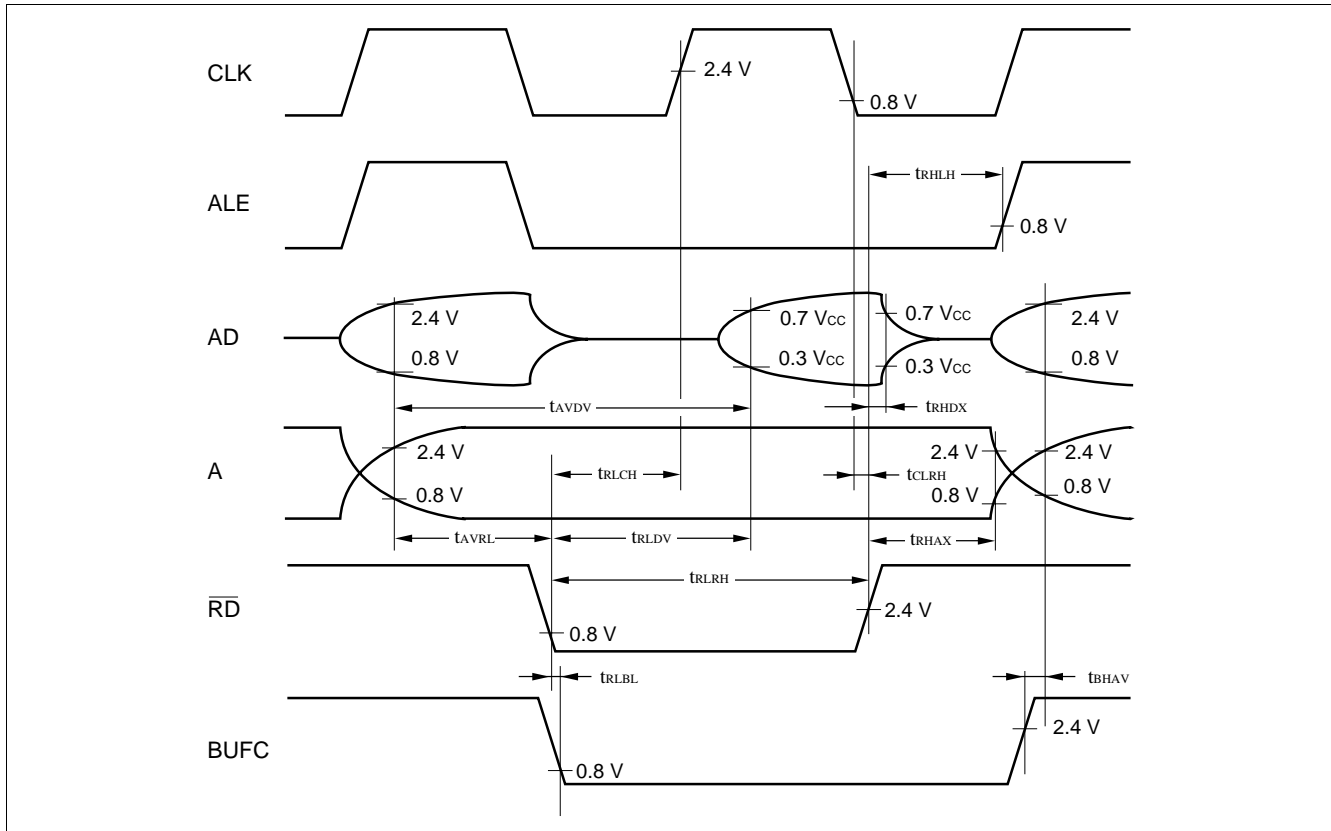

(7) Bus Write Timing

($V_{CC} = +5.0 V \pm 10\%$, $F_C = 10 \text{ MHz}$, $A_{VSS} = V_{SS} = 0.0 \text{ V}$, $T_A = -40^\circ\text{C}$ to $+85^\circ\text{C}$)

Parameter	Symbol	Pin name	Condition	Value (10 MHz)		Unit	Remarks
				Min.	Max.		
Valid address → ALE ↓ time	t_{AVLL}	AD7 to AD0, ALE, A15 to A08	Load condition: 50 pF	$1/4 t_{inst}^{*1} - 64 \text{ ns}$	—	ns	
ALE ↓ time → address invalid time	t_{LLAX}			5	—	ns	
Valid address → \overline{WR} ↓ time	t_{AVWL}	\overline{WR} , ALE		$1/4 t_{inst}^{*1} - 60 \text{ ns}$	—	ns	
\overline{WR} pulse width	t_{WLWH}	\overline{WR}		$1/2 t_{inst}^{*1} - 20 \text{ ns}$	—	ns	
Write data → \overline{WR} ↑ time	t_{DVWH}	AD7 to AD0, \overline{WR}		$1/2 t_{inst}^{*1} - 60 \text{ ns}$	—	ns	
\overline{WR} ↑ → address invalid time	t_{WHAX}	\overline{WR} , A15 to A08		$1/4 t_{inst}^{*1} - 40 \text{ ns}$	—	ns	
\overline{WR} ↑ → data hold time	t_{WHDX}	AD7 to AD0, \overline{WR}		$1/4 t_{inst}^{*1} - 40 \text{ ns}$	—	ns	
\overline{WR} ↑ → ALE ↑ time	t_{WHLH}	\overline{WR} , ALE		$1/4 t_{inst}^{*1} - 40 \text{ ns}$	—	ns	
\overline{WR} ↓ → CLK ↑ time	t_{WLCH}	\overline{WR} , CLK		$1/4 t_{inst}^{*1} - 60 \text{ ns}$	—	ns	
CLK ↓ → \overline{WR} ↑ time	t_{CLWH}			0	—	ns	
ALE pulse width	t_{LHLL}	ALE	$t_{XCYL} - 35 \text{ ns}^2$	—	ns		
ALE ↓ → CLK ↑ time	t_{LLCH}	ALE, CLK	$t_{XCYL} - 35 \text{ ns}^2$	—	ns		

*1: For information on t_{inst} , see “(4) Instruction Cycle.”

*2: These characteristics are also applicable to the bus read timing.

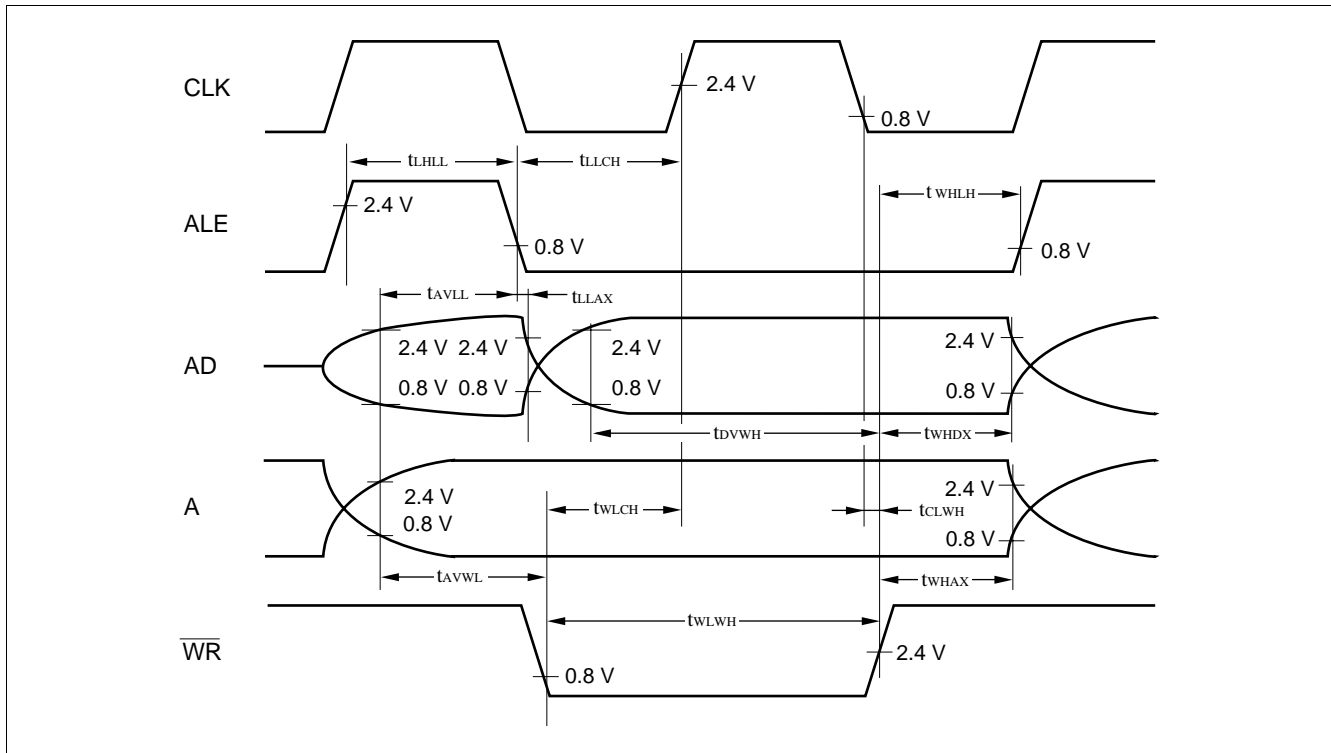

MB89850R Series

(8) Ready Input Timing

($V_{CC} = +5.0 V \pm 10\%$, $F_C = 10 \text{ MHz}$, $A_{V_{SS}} = V_{SS} = 0.0 \text{ V}$, $T_A = -40^\circ\text{C}$ to $+85^\circ\text{C}$)

Parameter	Symbol	Pin name	Condition	Value		Unit	Remarks
				Min.	Max.		
RDY valid \rightarrow CLK \uparrow time	t_{YVCH}	RDY, CLK	Load condition: 50 pF	60	—	ns	*
CLK \uparrow \rightarrow RDY invalid time	t_{CHYX}			0	—	ns	*

* : These characteristics are also applicable to the read cycle.

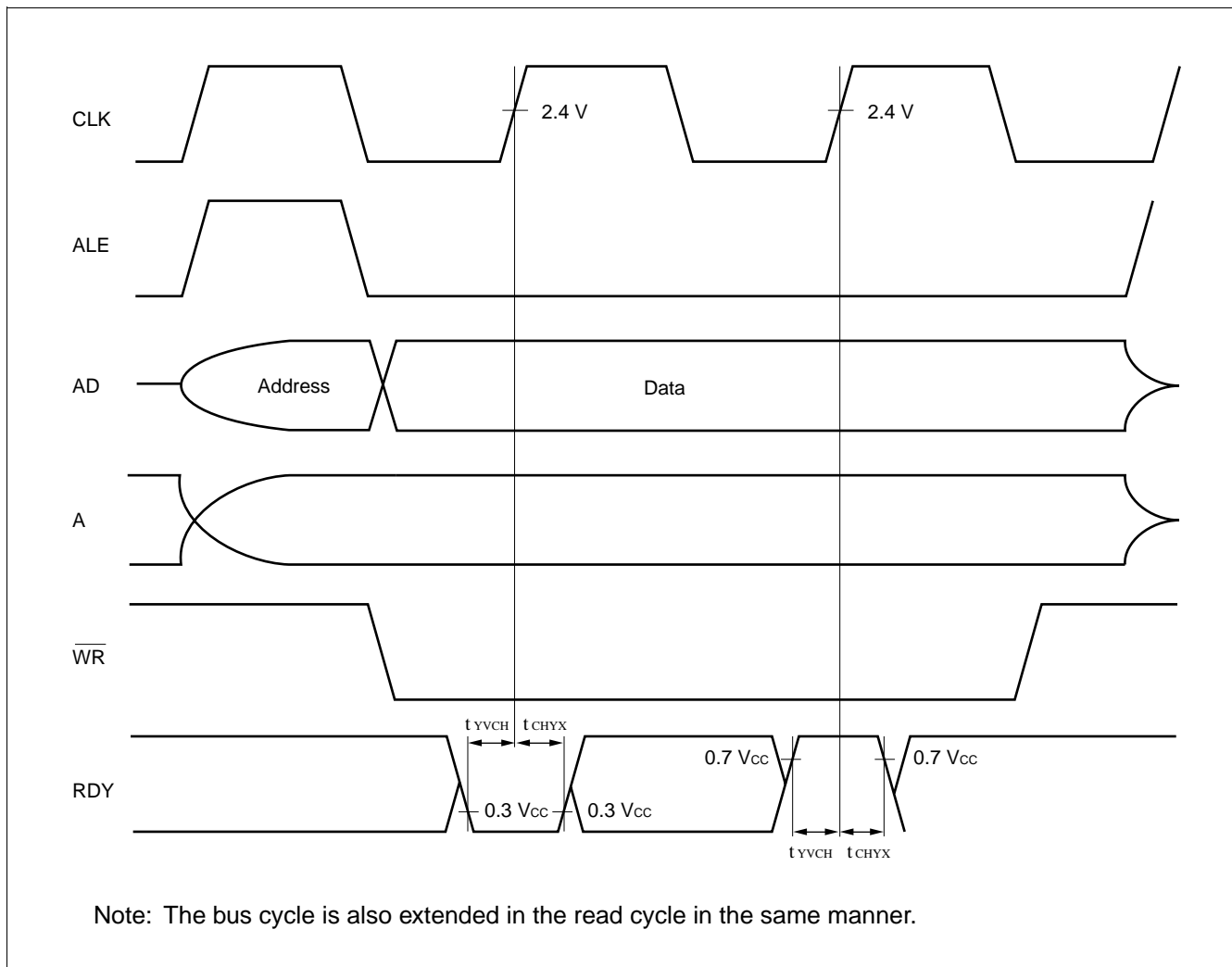

MB89850R Series

(9) UART and Serial I/O Timing

($V_{CC} = +5.0 V \pm 10\%$, $AV_{SS} = V_{SS} = 0.0 V$, $T_A = -40^\circ C$ to $+85^\circ C$)

Parameter	Symbol	Pin name	Condition	Value		Unit	Remarks
				Min.	Max.		
Serial clock cycle time	t_{SCYC}	SCK1, SCK2	Internal shift clock mode Load condition: 50 pF	$2 t_{inst}^*$	—	μs	
SCK1 $\downarrow \rightarrow$ SO1 time SCK2 $\downarrow \rightarrow$ SO2 time	t_{SLOV}	SCK1, SO1 SCK2, SO2		-200	200	ns	
Valid SI1 \rightarrow SCK1 \uparrow Valid SI2 \rightarrow SCK2 \uparrow	t_{IVSH}	SI1, SCK1 SI2, SCK2		$1/2 t_{inst}^*$	—	μs	
SCK1 $\uparrow \rightarrow$ valid SI1 hold time SCK2 $\uparrow \rightarrow$ valid SI2 hold time	t_{SHIX}	SCK1, SI1 SCK2, SI2		$1/2 t_{inst}^*$	—	μs	
Serial clock "H" pulse width	t_{SHSL}	SCK1, SCK2	External shift clock mode Load condition: 50 pF	$1 t_{inst}^*$	—	μs	
Serial clock "L" pulse width	t_{SLSH}			$1 t_{inst}^*$	—	μs	
SCK1 $\downarrow \rightarrow$ SO1 time SCK2 $\downarrow \rightarrow$ SO2 time	t_{SLOV}	SCK1, SO1 SCK2, SO2		0	200	ns	
Valid SI1 \rightarrow SCK1 \uparrow Valid SI2 \rightarrow SCK2 \uparrow	t_{IVSH}	SI1, SCK1 SI2, SCK2		$1/2 t_{inst}^*$	—	μs	
SCK1 $\uparrow \rightarrow$ valid SI1 hold time SCK2 $\uparrow \rightarrow$ valid SI2 hold time	t_{SHIX}	SCK1, SI1 SCK2, SI2		$1/2 t_{inst}^*$	—	μs	

* : For information on t_{inst} , see "(4) Instruction Cycle."

MB89850R Series

• Internal Shift Clock Mode

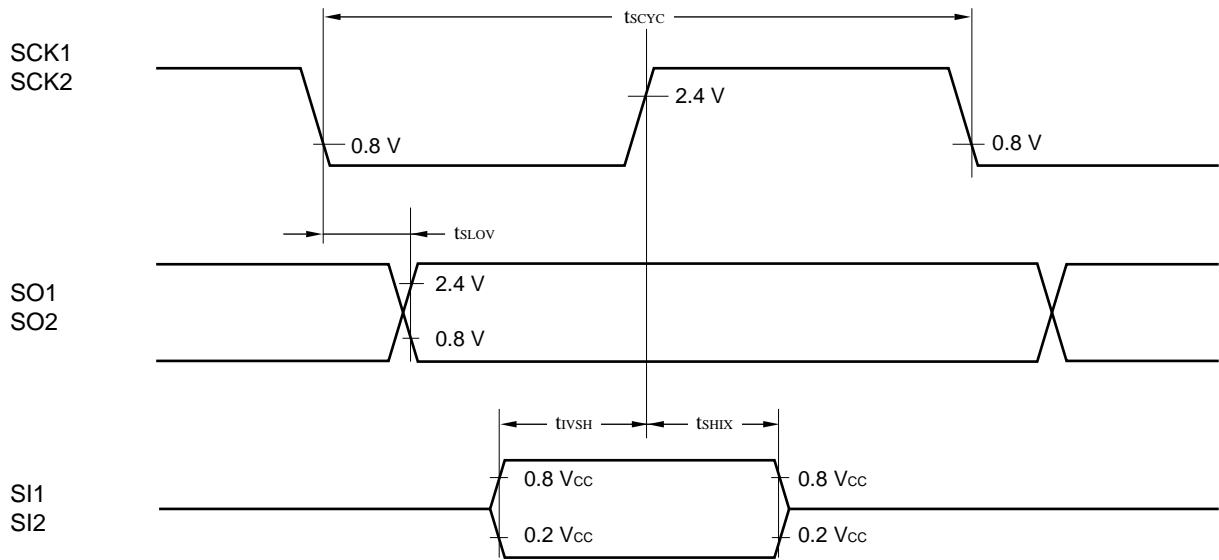

• External Shift Clock Mode

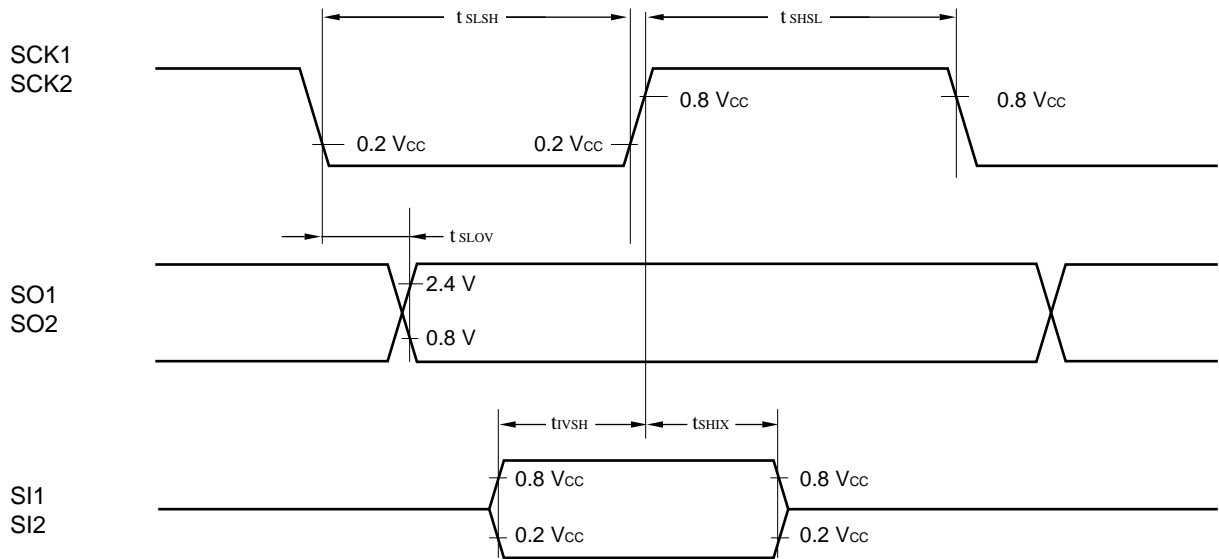

(10) Peripheral Input Timing

($V_{CC} = +5.0\text{ V} \pm 10\%$, $AV_{SS} = V_{SS} = 0.0\text{ V}$, $T_A = -40^\circ\text{C}$ to $+85^\circ\text{C}$)

Parameter	Symbol	Pin name	Condition	Value		Unit	Remarks
				Min.	Max.		
Peripheral input "H" pulse width 1	t_{LH1}	TRGI, DTTI, ADST, INT0 to INT3	Load condition: 50 pF	$2 t_{inst}^*$	—	μs	
Peripheral input "L" pulse width 1	t_{HL1}			$2 t_{inst}^*$	—	μs	

* : For information on t_{inst} , see "(4) Instruction Cycle."

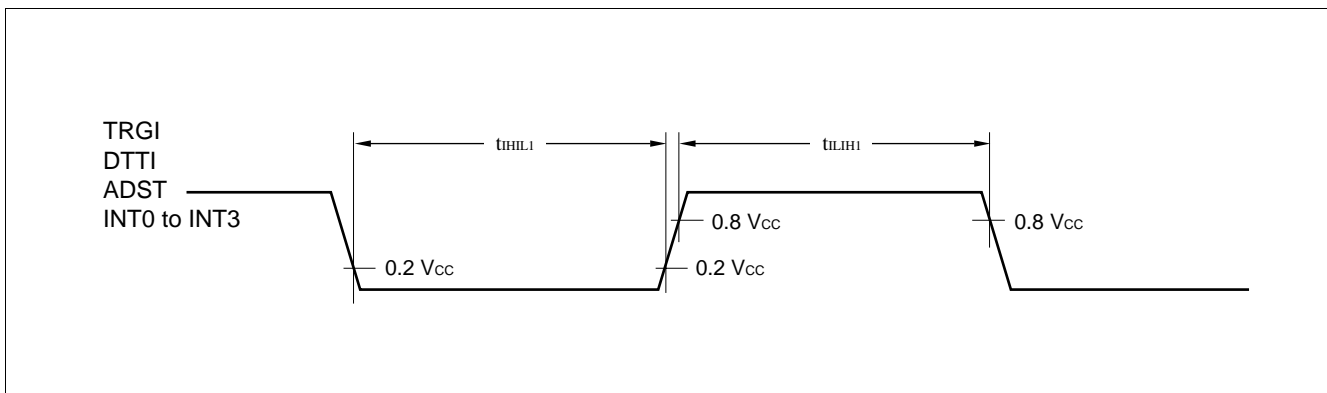

5. A/D Converter Electrical Characteristics

($AV_{CC} = V_{CC} = +3.5\text{ V}$ to $+6.0\text{ V}$, $F_C = 10\text{ MHz}$, $AV_{SS} = V_{SS} = 0.0\text{ V}$, $T_A = -40^\circ\text{C}$ to $+85^\circ\text{C}$)

Parameter	Symbol	Pin name	Condition	Value			Unit	Remarks
				Min.	Typ.	Max.		
Resolution	—	—	$AV_{CC} = V_{CC}$	—	—	10	bit	
Linearity error	—	—		—	—	± 2.0	LSB	
Differential linearity error				—	—	± 1.5	LSB	
Total error				—	—	± 3.0	LSB	
Zero transition voltage				V_{OT}	AN0 to AN7	$AV_{SS} - 1.5$	$AV_{SS} + 0.5$	$AV_{SS} + 2.5$
Full-scale transition voltage	V_{FST}	AN0 to AN7	$AVR - 3.5$	$AVR - 1.5$	$AVR + 0.5$	LSB		
Interchannel disparity	—	—	—	—	4	LSB		
A/D mode conversion time	—	—	—	—	$33 t_{inst}^*$	μs		
Analog port input current	I_{AIN}	AN0 to AN7	—	—	10	μA		
Analog input voltage	—	AN0 to AN7	—	0	—	AVR	V	
Reference voltage	—		—	0	—	AV_{CC}	V	
Reference voltage supply current	I_R	AVR	$AVR = 5.0\text{ V}$	—	200	—	μA	

* : For information on t_{inst} , see "(4) Instruction Cycle" in "4. AC Characteristics."

MB89850R Series

6. A/D Converter Glossary

- Resolution
Analog changes that are identifiable with the A/D converter
- Linearity error
The deviation of the straight line connecting the zero transition point (“00 0000 0000” ↔ “00 0000 0001”) with the full-scale transition point (“11 1111 1111” ↔ “11 1111 1110”) from actual conversion characteristics
- Differential linearity error
The deviation of input voltage needed to change the output code by 1 LSB from the theoretical value
- Total error
The total error indicates the difference between the actual value and theoretical value. This error is caused by the zero transition error, full-scale transition error, linearity error, quantization, and noise.

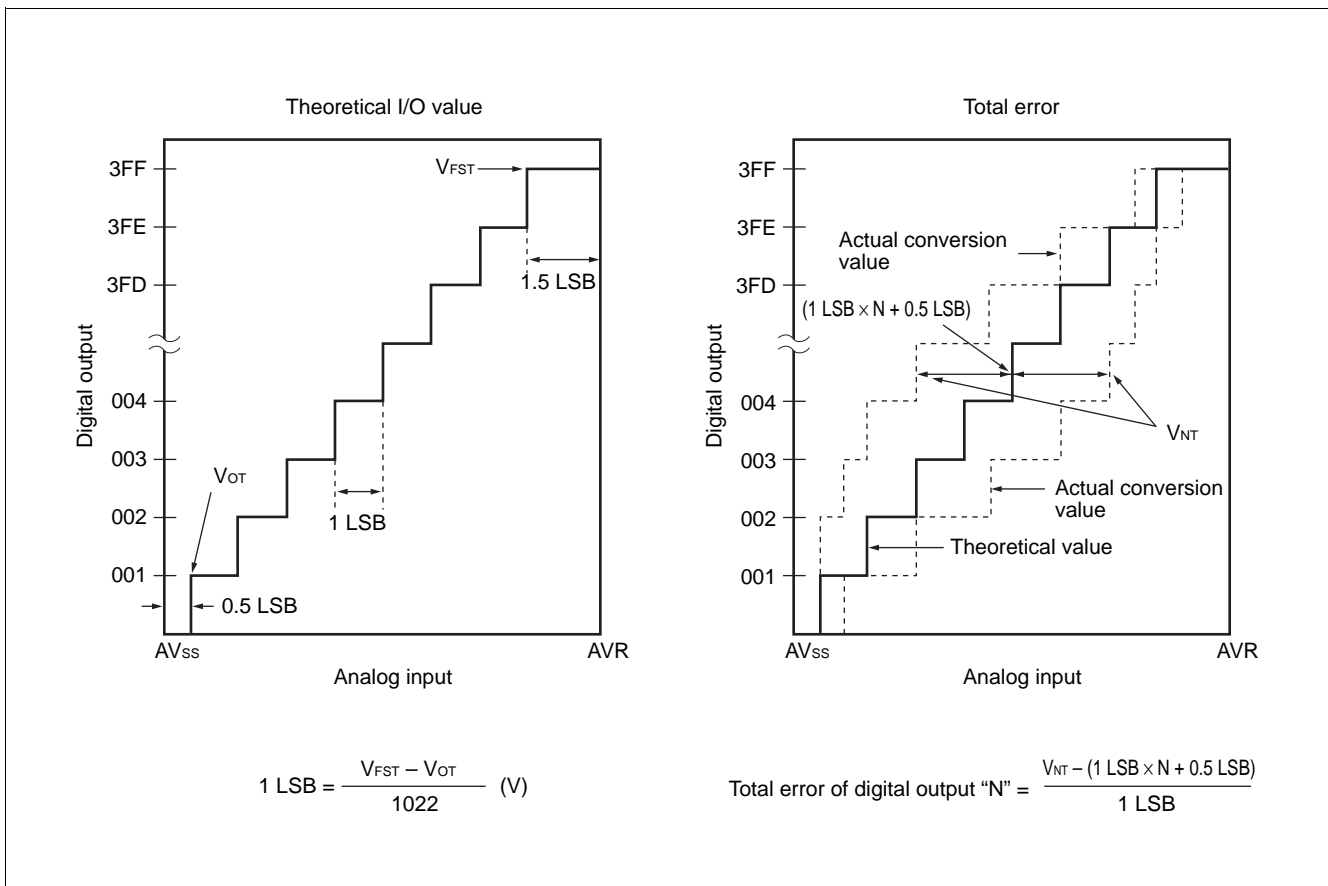

(Continued)

(Continued)

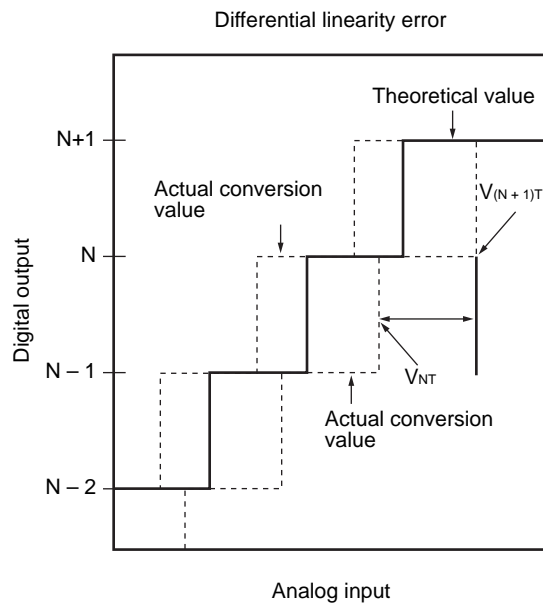
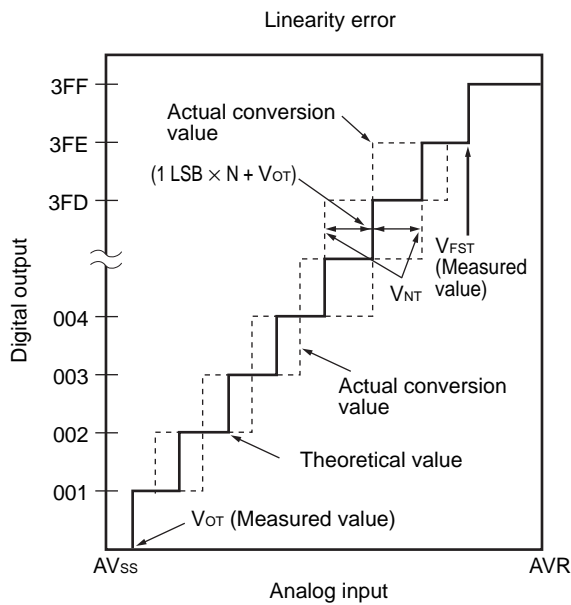
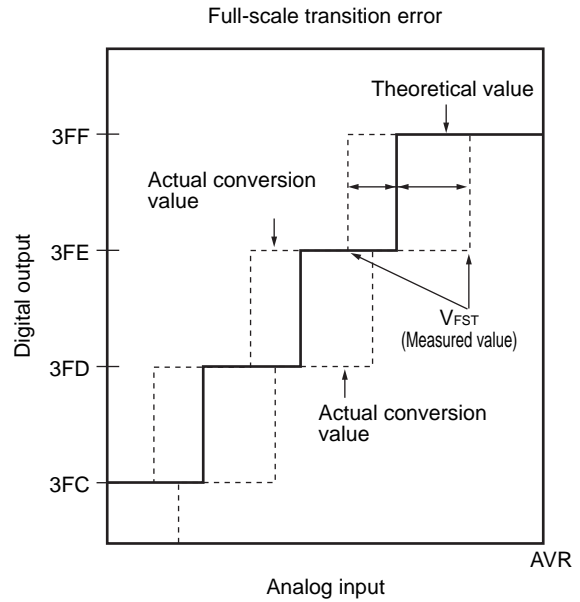
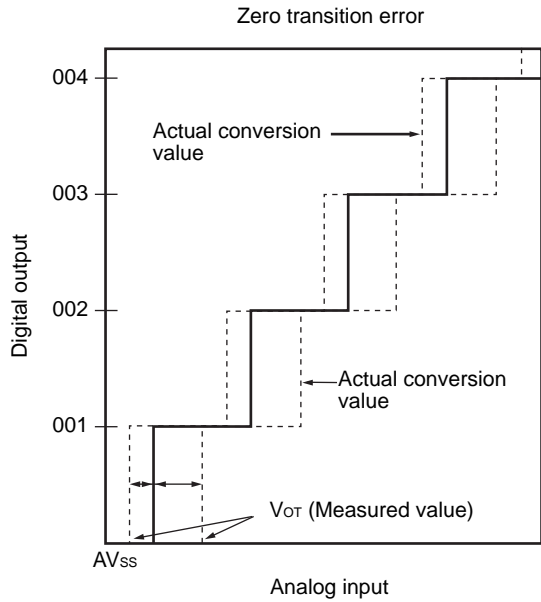

$$\text{Linearity error of digital output "N"} = \frac{V_{NT} - (1 \text{ LSB} \times N + V_{OT})}{1 \text{ LSB}}$$

$$\text{Differential linearity error of digital output "N"} = \frac{V_{(N+1)T} - V_{NT}}{1 \text{ LSB}} - 1$$

MB89850R Series

7. Notes on Using A/D Converter

- **Input impedance of the analog input pins**

The A/D converter used for the MB89860/850 series contains a sample hold circuit as illustrated below to fetch analog input voltage into the sample hold capacitor for fifteen instruction cycles after activation A/D conversion.

For this reason, if the output impedance of the external circuit for the analog input is high, analog input voltage might not stabilize within the analog input sampling period. Therefore, it is recommended to keep the output impedance of the external circuit low (below 10 k Ω).

Note that if the impedance cannot be kept low, it is recommended to connect an external capacitor of about 0.1 μ F for the analog input pin.

- **Analog Input Equivalent Circuit**

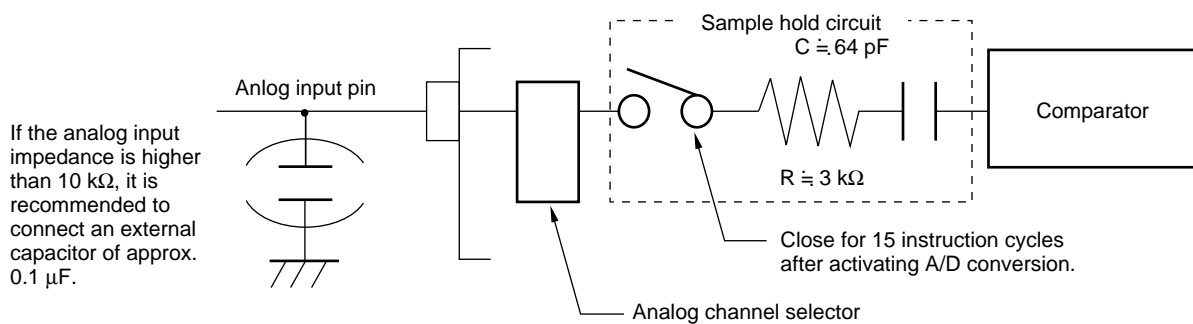

- **Error**

The smaller the $|AVR - AV_{SS}|$, the greater the error would become relatively.

EXAMPLE CHARACTERISTICS

(1) "L" Level Output Voltage (P00 to P07, P10 to P17, P20 to P27, P30 to P37, and P50 to P57)

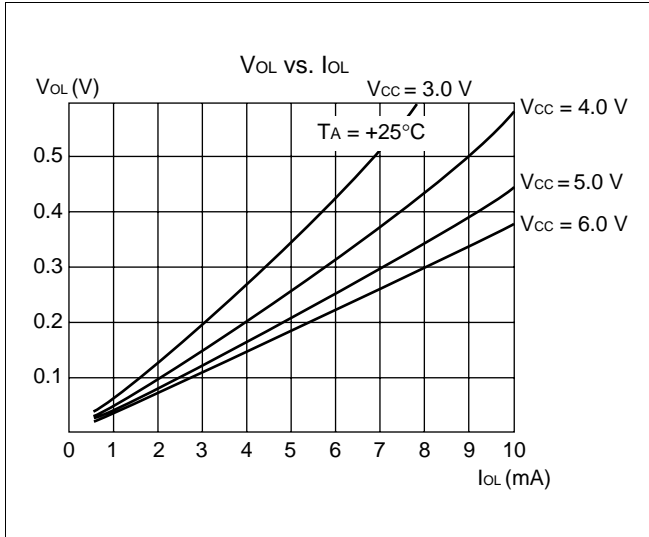

(2) "L" Level Output Voltage (P40 to P47)

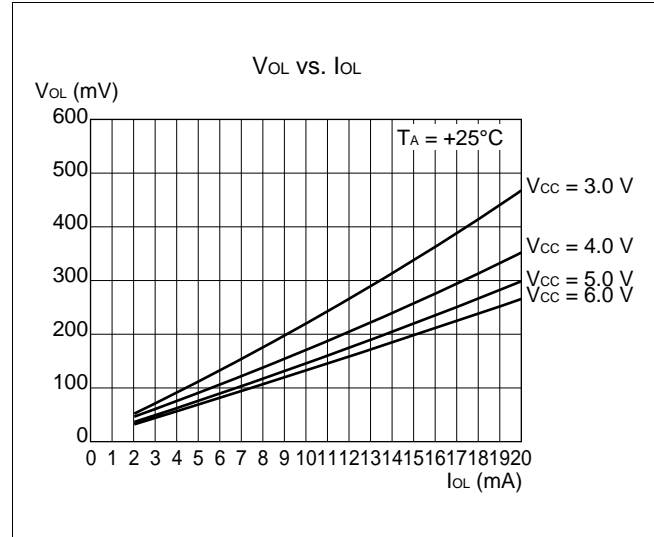

(3) "H" Level Output Voltage (P00 to P07, P10 to P17, P20 to P27, P30 to P37, and P40 to P47)

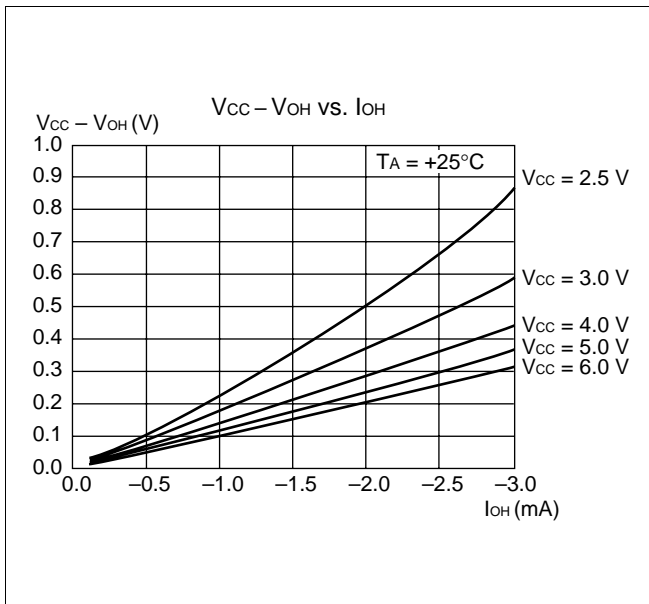

(4) Pull-up Resistance

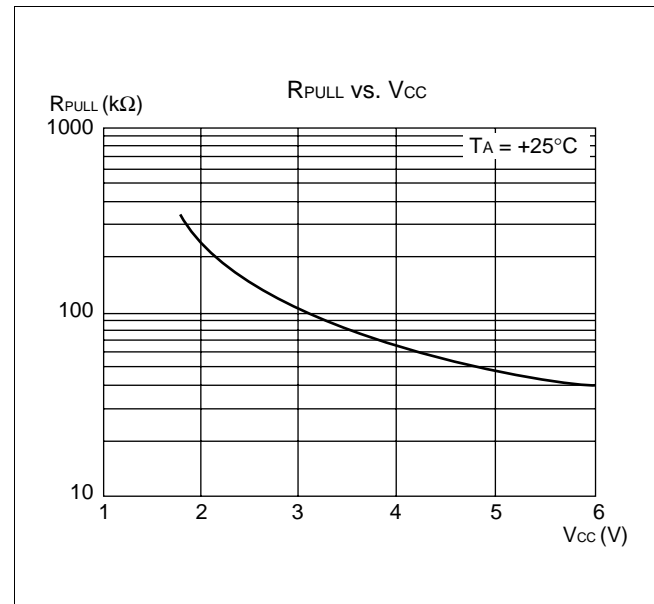

MB89850R Series

(5) "H" Level Input Voltage/"L" Level Input Voltage (CMOS Input)

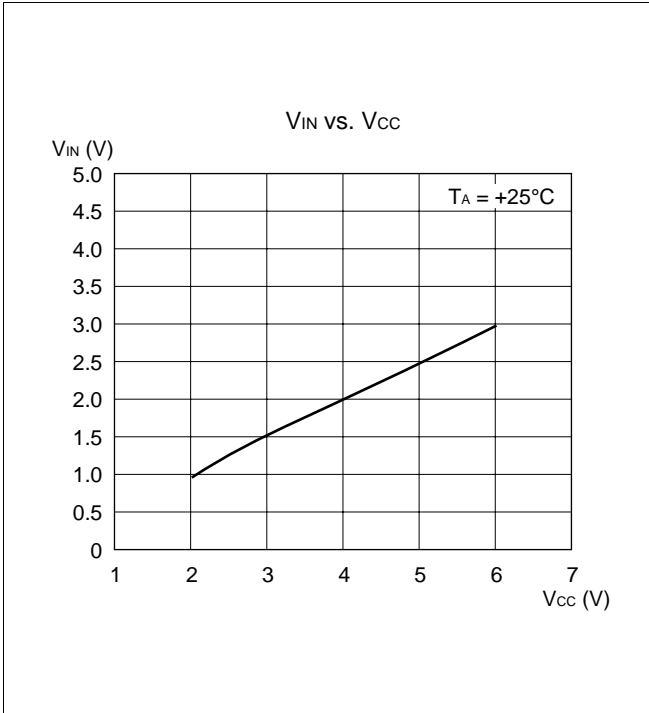

(6) "H" Level Input Voltage/"L" level Input Voltage (Hysteresis Input)



(7) Operating Supply Current vs. Frequency

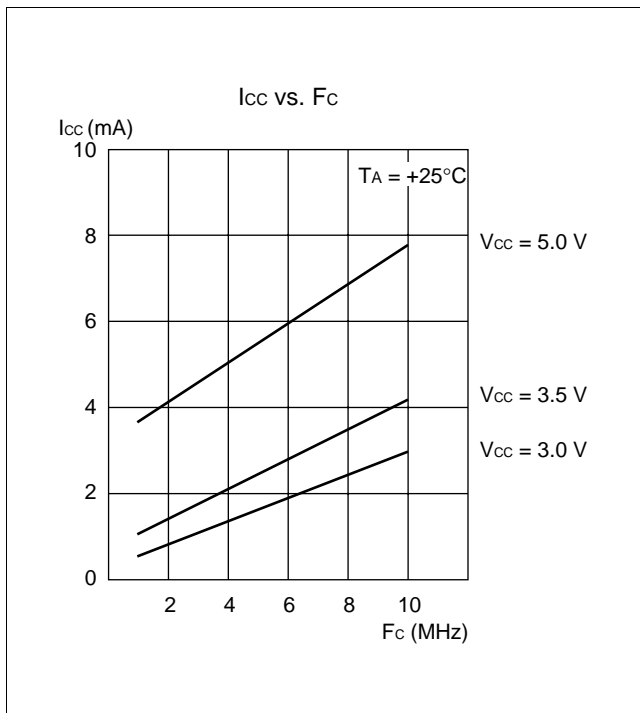

(8) Operating Supply Current vs. VCC

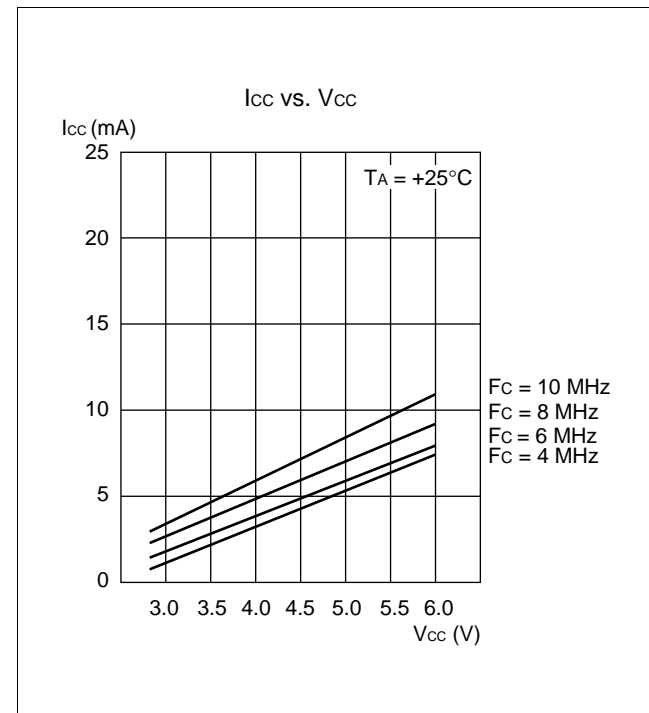

(9) Sleep Power Supply Current vs. Frequency

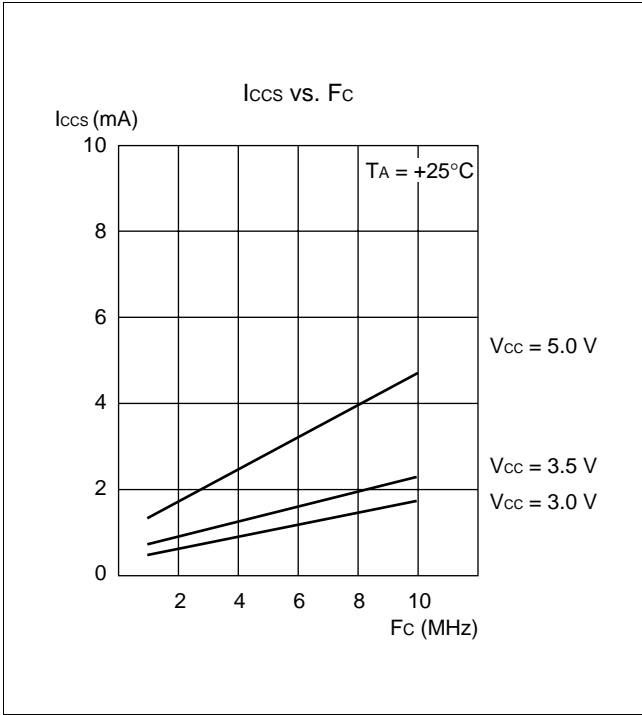

(10) Sleep Power Supply Current vs. V_{cc}

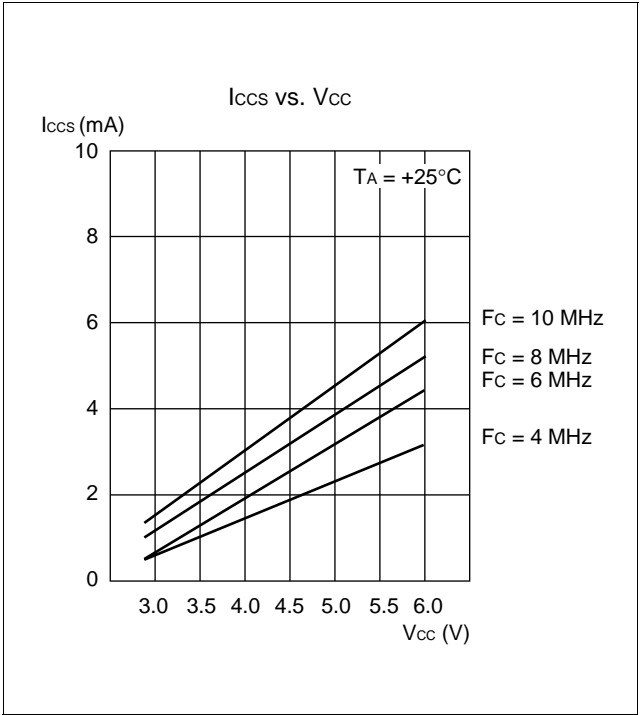

MB89850R Series

■ INSTRUCTIONS (136 INSTRUCTIONS)

Execution instructions can be divided into the following four groups:

- Transfer
- Arithmetic operation
- Branch
- Others

Table 1 lists symbols used for notation of instructions.

Table 1 Instruction Symbols

Symbol	Meaning
dir	Direct address (8 bits)
off	Offset (8 bits)
ext	Extended address (16 bits)
#vct	Vector table number (3 bits)
#d8	Immediate data (8 bits)
#d16	Immediate data (16 bits)
dir: b	Bit direct address (8:3 bits)
rel	Branch relative address (8 bits)
@	Register indirect (Example: @A, @IX, @EP)
A	Accumulator A (Whether its length is 8 or 16 bits is determined by the instruction in use.)
AH	Upper 8 bits of accumulator A (8 bits)
AL	Lower 8 bits of accumulator A (8 bits)
T	Temporary accumulator T (Whether its length is 8 or 16 bits is determined by the instruction in use.)
TH	Upper 8 bits of temporary accumulator T (8 bits)
TL	Lower 8 bits of temporary accumulator T (8 bits)
IX	Index register IX (16 bits)
EP	Extra pointer EP (16 bits)
PC	Program counter PC (16 bits)
SP	Stack pointer SP (16 bits)
PS	Program status PS (16 bits)
dr	Accumulator A or index register IX (16 bits)
CCR	Condition code register CCR (8 bits)
RP	Register bank pointer RP (5 bits)
Ri	General-purpose register Ri (8 bits, i = 0 to 7)
×	Indicates that the very × is the immediate data. (Whether its length is 8 or 16 bits is determined by the instruction in use.)
(×)	Indicates that the contents of × is the target of accessing. (Whether its length is 8 or 16 bits is determined by the instruction in use.)
((×))	The address indicated by the contents of × is the target of accessing. (Whether its length is 8 or 16 bits is determined by the instruction in use.)

Columns indicate the following:

Mnemonic: Assembler notation of an instruction

~: The number of instructions

#: The number of bytes

Operation: Operation of an instruction

TL, TH, AH: A content change when each of the TL, TH, and AH instructions is executed. Symbols in the column indicate the following:

- “-” indicates no change.
- dH is the 8 upper bits of operation description data.
- AL and AH must become the contents of AL and AH prior to the instruction executed.
- 00 becomes 00.

N, Z, V, C: An instruction of which the corresponding flag will change. If + is written in this column, the relevant instruction will change its corresponding flag.

OP code: Code of an instruction. If an instruction is more than one code, it is written according to the following rule:

Example: 48 to 4F ← This indicates 48, 49, ... 4F.

Table 2 Transfer Instructions (48 instructions)

Mnemonic	~	#	Operation	TL	TH	AH	NZVC	OP code
MOV dir,A	3	2	(dir) ← (A)	-	-	-	-----	45
MOV @IX +off,A	4	2	((IX) +off) ← (A)	-	-	-	-----	46
MOV ext,A	4	3	(ext) ← (A)	-	-	-	-----	61
MOV @EP,A	3	1	((EP)) ← (A)	-	-	-	-----	47
MOV Ri,A	3	1	(Ri) ← (A)	-	-	-	-----	48 to 4F
MOV A,#d8	2	2	(A) ← d8	AL	-	-	++--	04
MOV A,dir	3	2	(A) ← (dir)	AL	-	-	++--	05
MOV A,@IX +off	4	2	(A) ← ((IX) +off)	AL	-	-	++--	06
MOV A,ext	4	3	(A) ← (ext)	AL	-	-	++--	60
MOV A,@A	3	1	(A) ← ((A))	AL	-	-	++--	92
MOV A,@EP	3	1	(A) ← ((EP))	AL	-	-	++--	07
MOV A,Ri	3	1	(A) ← (Ri)	AL	-	-	++--	08 to 0F
MOV dir,#d8	4	3	(dir) ← d8	-	-	-	-----	85
MOV @IX +off,#d8	5	3	((IX) +off) ← d8	-	-	-	-----	86
MOV @EP,#d8	4	2	((EP)) ← d8	-	-	-	-----	87
MOV Ri,#d8	4	2	(Ri) ← d8	-	-	-	-----	88 to 8F
MOVW dir,A	4	2	(dir) ← (AH),(dir + 1) ← (AL)	-	-	-	-----	D5
MOVW @IX +off,A	5	2	((IX) +off) ← (AH), ((IX) +off + 1) ← (AL)	-	-	-	-----	D6
MOVW ext,A	5	3	(ext) ← (AH), (ext + 1) ← (AL)	-	-	-	-----	D4
MOVW @EP,A	4	1	((EP)) ← (AH),((EP) + 1) ← (AL)	-	-	-	-----	D7
MOVW EP,A	2	1	(EP) ← (A)	-	-	-	-----	E3
MOVW A,#d16	3	3	(A) ← d16	AL	AH	dH	++--	E4
MOVW A,dir	4	2	(AH) ← (dir), (AL) ← (dir + 1)	AL	AH	dH	++--	C5
MOVW A,@IX +off	5	2	(AH) ← ((IX) +off), (AL) ← ((IX) +off + 1)	AL	AH	dH	++--	C6
MOVW A,ext	5	3	(AH) ← (ext), (AL) ← (ext + 1)	AL	AH	dH	++--	C4
MOVW A,@A	4	1	(AH) ← ((A)), (AL) ← ((A)) + 1)	AL	AH	dH	++--	93
MOVW A,@EP	4	1	(AH) ← ((EP)), (AL) ← ((EP) + 1)	AL	AH	dH	++--	C7
MOVW A,EP	2	1	(A) ← (EP)	-	-	dH	-----	F3
MOVW EP,#d16	3	3	(EP) ← d16	-	-	-	-----	E7
MOVW IX,A	2	1	(IX) ← (A)	-	-	-	-----	E2
MOVW A,IX	2	1	(A) ← (IX)	-	-	dH	-----	F2
MOVW SP,A	2	1	(SP) ← (A)	-	-	-	-----	E1
MOVW A,SP	2	1	(A) ← (SP)	-	-	dH	-----	F1
MOV @A,T	3	1	((A)) ← (T)	-	-	-	-----	82
MOVW @A,T	4	1	((A)) ← (TH),((A) + 1) ← (TL)	-	-	-	-----	83
MOVW IX,#d16	3	3	(IX) ← d16	-	-	-	-----	E6
MOVW A,PS	2	1	(A) ← (PS)	-	-	dH	-----	70
MOVW PS,A	2	1	(PS) ← (A)	-	-	-	++++	71
MOVW SP,#d16	3	3	(SP) ← d16	-	-	-	-----	E5
SWAP	2	1	(AH) ↔ (AL)	-	-	AL	-----	10
SETB dir: b	4	2	(dir): b ← 1	-	-	-	-----	A8 to AF
CLRB dir: b	4	2	(dir): b ← 0	-	-	-	-----	A0 to A7
XCH A,T	2	1	(AL) ↔ (TL)	AL	-	-	-----	42
XCHW A,T	3	1	(A) ↔ (T)	AL	AH	dH	-----	43
XCHW A,EP	3	1	(A) ↔ (EP)	-	-	dH	-----	F7
XCHW A,IX	3	1	(A) ↔ (IX)	-	-	dH	-----	F6
XCHW A,SP	3	1	(A) ↔ (SP)	-	-	dH	-----	F5
MOVW A,PC	2	1	(A) ← (PC)	-	-	dH	-----	F0

Note During byte transfer to A, T ← A is restricted to low bytes.

Operands in more than one operand instruction must be stored in the order in which their mnemonics are written. (Reverse arrangement of F²MC-8 family)

MB89850R Series

Table 3 Arithmetic Operation Instructions (62 instructions)

Mnemonic	~	#	Operation	TL	TH	AH	NZVC	OP code
ADDC A,Ri	3	1	$(A) \leftarrow (A) + (Ri) + C$	-	-	-	++++	28 to 2F
ADDC A,#d8	2	2	$(A) \leftarrow (A) + d8 + C$	-	-	-	++++	24
ADDC A,dir	3	2	$(A) \leftarrow (A) + (dir) + C$	-	-	-	++++	25
ADDC A,@IX +off	4	2	$(A) \leftarrow (A) + ((IX) + off) + C$	-	-	-	++++	26
ADDC A,@EP	3	1	$(A) \leftarrow (A) + ((EP)) + C$	-	-	-	++++	27
ADDCW A	3	1	$(A) \leftarrow (A) + (T) + C$	-	-	dH	++++	23
ADDC A	2	1	$(AL) \leftarrow (AL) + (TL) + C$	-	-	-	++++	22
SUBC A,Ri	3	1	$(A) \leftarrow (A) - (Ri) - C$	-	-	-	++++	38 to 3F
SUBC A,#d8	2	2	$(A) \leftarrow (A) - d8 - C$	-	-	-	++++	34
SUBC A,dir	3	2	$(A) \leftarrow (A) - (dir) - C$	-	-	-	++++	35
SUBC A,@IX +off	4	2	$(A) \leftarrow (A) - ((IX) + off) - C$	-	-	-	++++	36
SUBC A,@EP	3	1	$(A) \leftarrow (A) - ((EP)) - C$	-	-	-	++++	37
SUBCW A	3	1	$(A) \leftarrow (T) - (A) - C$	-	-	dH	++++	33
SUBC A	2	1	$(AL) \leftarrow (TL) - (AL) - C$	-	-	-	++++	32
INC Ri	4	1	$(Ri) \leftarrow (Ri) + 1$	-	-	-	+++-	C8 to CF
INCW EP	3	1	$(EP) \leftarrow (EP) + 1$	-	-	-	----	C3
INCW IX	3	1	$(IX) \leftarrow (IX) + 1$	-	-	-	----	C2
INCW A	3	1	$(A) \leftarrow (A) + 1$	-	-	dH	+- - -	C0
DEC Ri	4	1	$(Ri) \leftarrow (Ri) - 1$	-	-	-	+++-	D8 to DF
DECW EP	3	1	$(EP) \leftarrow (EP) - 1$	-	-	-	----	D3
DECW IX	3	1	$(IX) \leftarrow (IX) - 1$	-	-	-	----	D2
DECW A	3	1	$(A) \leftarrow (A) - 1$	-	-	dH	+- - -	D0
MULU A	19	1	$(A) \leftarrow (AL) \times (TL)$	-	-	dH	----	01
DIVU A	21	1	$(A) \leftarrow (T) / (AL), MOD \rightarrow (T)$	dL	00	00	----	11
ANDW A	3	1	$(A) \leftarrow (A) \wedge (T)$	-	-	dH	++R-	63
ORW A	3	1	$(A) \leftarrow (A) \vee (T)$	-	-	dH	++R-	73
XORW A	3	1	$(A) \leftarrow (A) \nabla (T)$	-	-	dH	++R-	53
CMP A	2	1	$(TL) - (AL)$	-	-	-	++++	12
CMPW A	3	1	$(T) - (A)$	-	-	-	++++	13
RORC A	2	1	$\rightarrow C \rightarrow A$	-	-	-	++-+	03
ROLC A	2	1	$C \leftarrow A \leftarrow$	-	-	-	++-+	02
CMP A,#d8	2	2	$(A) - d8$	-	-	-	++++	14
CMP A,dir	3	2	$(A) - (dir)$	-	-	-	++++	15
CMP A,@EP	3	1	$(A) - ((EP))$	-	-	-	++++	17
CMP A,@IX +off	4	2	$(A) - ((IX) + off)$	-	-	-	++++	16
CMP A,Ri	3	1	$(A) - (Ri)$	-	-	-	++++	18 to 1F
DAA	2	1	Decimal adjust for addition	-	-	-	++++	84
DAS	2	1	Decimal adjust for subtraction	-	-	-	++++	94
XOR A	2	1	$(A) \leftarrow (AL) \nabla (TL)$	-	-	-	++R-	52
XOR A,#d8	2	2	$(A) \leftarrow (AL) \nabla d8$	-	-	-	++R-	54
XOR A,dir	3	2	$(A) \leftarrow (AL) \nabla (dir)$	-	-	-	++R-	55
XOR A,@EP	3	1	$(A) \leftarrow (AL) \nabla ((EP))$	-	-	-	++R-	57
XOR A,@IX +off	4	2	$(A) \leftarrow (AL) \nabla ((IX) + off)$	-	-	-	++R-	56
XOR A,Ri	3	1	$(A) \leftarrow (AL) \nabla (Ri)$	-	-	-	++R-	58 to 5F
AND A	2	1	$(A) \leftarrow (AL) \wedge (TL)$	-	-	-	++R-	62
AND A,#d8	2	2	$(A) \leftarrow (AL) \wedge d8$	-	-	-	++R-	64
AND A,dir	3	2	$(A) \leftarrow (AL) \wedge (dir)$	-	-	-	++R-	65

(Continued)

(Continued)

Mnemonic	~	#	Operation	TL	TH	AH	NZVC	OP code
AND A,@EP	3	1	$(A) \leftarrow (AL) \wedge (EP)$	-	-	-	++R-	67
AND A,@IX +off	4	2	$(A) \leftarrow (AL) \wedge ((IX) + \text{off})$	-	-	-	++R-	66
AND A,Ri	3	1	$(A) \leftarrow (AL) \wedge (Ri)$	-	-	-	++R-	68 to 6F
OR A	2	1	$(A) \leftarrow (AL) \vee (TL)$	-	-	-	++R-	72
OR A,#d8	2	2	$(A) \leftarrow (AL) \vee d8$	-	-	-	++R-	74
OR A,dir	3	2	$(A) \leftarrow (AL) \vee (\text{dir})$	-	-	-	++R-	75
OR A,@EP	3	1	$(A) \leftarrow (AL) \vee (EP)$	-	-	-	++R-	77
OR A,@IX +off	4	2	$(A) \leftarrow (AL) \vee ((IX) + \text{off})$	-	-	-	++R-	76
OR A,Ri	3	1	$(A) \leftarrow (AL) \vee (Ri)$	-	-	-	++R-	78 to 7F
CMP dir,#d8	5	3	$(\text{dir}) - d8$	-	-	-	++++	95
CMP @EP,#d8	4	2	$(EP) - d8$	-	-	-	++++	97
CMP @IX +off,#d8	5	3	$((IX) + \text{off}) - d8$	-	-	-	++++	96
CMP Ri,#d8	4	2	$(Ri) - d8$	-	-	-	++++	98 to 9F
INCW SP	3	1	$(SP) \leftarrow (SP) + 1$	-	-	-	----	C1
DECW SP	3	1	$(SP) \leftarrow (SP) - 1$	-	-	-	----	D1

Table 4 Branch Instructions (17 instructions)

Mnemonic	~	#	Operation	TL	TH	AH	NZVC	OP code
BZ/BEQ rel	3	2	If $Z = 1$ then $PC \leftarrow PC + \text{rel}$	-	-	-	----	FD
BNZ/BNE rel	3	2	If $Z = 0$ then $PC \leftarrow PC + \text{rel}$	-	-	-	----	FC
BC/BLO rel	3	2	If $C = 1$ then $PC \leftarrow PC + \text{rel}$	-	-	-	----	F9
BNC/BHS rel	3	2	If $C = 0$ then $PC \leftarrow PC + \text{rel}$	-	-	-	----	F8
BN rel	3	2	If $N = 1$ then $PC \leftarrow PC + \text{rel}$	-	-	-	----	FB
BP rel	3	2	If $N = 0$ then $PC \leftarrow PC + \text{rel}$	-	-	-	----	FA
BLT rel	3	2	If $V \vee N = 1$ then $PC \leftarrow PC + \text{rel}$	-	-	-	----	FF
BGE rel	3	2	If $V \vee N = 0$ then $PC \leftarrow PC + \text{rel}$	-	-	-	----	FE
BBC dir: b,rel	5	3	If $(\text{dir}: b) = 0$ then $PC \leftarrow PC + \text{rel}$	-	-	-	-+---	B0 to B7
BBS dir: b,rel	5	3	If $(\text{dir}: b) = 1$ then $PC \leftarrow PC + \text{rel}$	-	-	-	-+---	B8 to BF
JMP @A	2	1	$(PC) \leftarrow (A)$	-	-	-	----	E0
JMP ext	3	3	$(PC) \leftarrow \text{ext}$	-	-	-	----	21
CALLV #vct	6	1	Vector call	-	-	-	----	E8 to EF
CALL ext	6	3	Subroutine call	-	-	-	----	31
XCHW A,PC	3	1	$(PC) \leftarrow (A), (A) \leftarrow (PC) + 1$	-	-	dH	----	F4
RET	4	1	Return from subroutine	-	-	-	----	20
RETI	6	1	Return from interrupt	-	-	-	Restore	30

Table 5 Other Instructions (9 instructions)

Mnemonic	~	#	Operation	TL	TH	AH	NZVC	OP code
PUSHW A	4	1		-	-	-	----	40
POPW A	4	1		-	-	dH	----	50
PUSHW IX	4	1		-	-	-	----	41
POPW IX	4	1		-	-	-	----	51
NOP	1	1		-	-	-	----	00
CLRC	1	1		-	-	-	----R	81
SETC	1	1		-	-	-	----S	91
CLRI	1	1		-	-	-	----	80
SETI	1	1		-	-	-	----	90

MB89850R Series

INSTRUCTION MAP

L	H	0	1	2	3	4	5	6	7	8	9	A	B	C	D	E	F
0	NOP	SWAP	RET	RETI	PUSHW A	PUSHW A	POPW A	MOV A,ext	MOVW A,PS	CLR	SETI	CLRB dir: 0	BBC dir: 0,rel	INCW A	DECW A	JMP @A	MOVW A,PC
1	MULU A	DIVU A	JMP addr16	CALL addr16	PUSHW IX	PUSHW IX	POPW PS,A	MOV ext,A	MOVW PS,A	CLRC	SETC	CLRB dir: 1	BBC dir: 1,rel	INCW SP	DECW SP	MOVW SPA	MOVW A,SP
2	ROLC A	CMP A	ADDC A	SUBC A	XCH A,T	XCH A,T	XOR A	AND A	OR A	MOV @A,T	MOV A,@A	CLRB dir: 2	BBC dir: 2,rel	INCW IX	DECW IX	MOVW IX,A	MOVW A,IX
3	RORC A	CMPW A	ADDCW A	SUBCW A	XCHW A,T	XCHW A,T	XORW A	ANDW A	ORW A	MOVW @A,T	MOVW A,@A	CLRB dir: 3	BBC dir: 3,rel	INCW EP	DECW EP	MOVW EPA	MOVW A,EP
4	MOV A,#d8	CMP A,#d8	ADDC A,#d8	SUBC A,#d8	XOR A,#d8	XOR A,#d8	XOR A,#d8	AND A,#d8	OR A,#d8	DAA	DAS	CLRB dir: 4	BBC dir: 4,rel	MOVW A,ext	MOVW ext,A	MOVW A,#d16	XCHW A,PC
5	MOV A,dir	CMP A,dir	ADDC A,dir	SUBC A,dir	XOR A,dir	XOR A,dir	XOR A,dir	AND A,dir	OR A,dir	MOV dir,#d8	CMP dir,#d8	CLRB dir: 5	BBC dir: 5,rel	MOVW A,dir	MOVW dir,A	MOVW SP,#d16	XCHW A,SP
6	MOV A,@IX+d	CMP A,@IX+d	ADDC A,@IX+d	SUBC A,@IX+d	XOR A,@IX+d	XOR A,@IX+d	XOR A,@IX+d	AND A,@IX+d	OR A,@IX+d	MOV @IX+d,#d8	CMP @IX+d,#d8	CLRB dir: 6	BBC dir: 6,rel	MOVW A,@IX+d	MOVW @IX+d,A	MOVW IX,#d16	XCHW A,IX
7	MOV A,@EP	CMP A,@EP	ADDC A,@EP	SUBC A,@EP	XOR A,@EP	XOR A,@EP	XOR A,@EP	AND A,@EP	OR A,@EP	MOV @EP,#d8	CMP @EP,#d8	CLRB dir: 7	BBC dir: 7,rel	MOVW A,@EP	MOVW @EP,A	MOVW EP,#d16	XCHW A,EP
8	MOV A,R0	CMP A,R0	ADDC A,R0	SUBC A,R0	XOR A,R0	XOR A,R0	XOR A,R0	AND A,R0	OR A,R0	MOV R0,#d8	CMP R0,#d8	SETB dir: 0	BBS dir: 0,rel	INC R0	DEC R0	CALLV #0	BNC rel
9	MOV A,R1	CMP A,R1	ADDC A,R1	SUBC A,R1	XOR A,R1	XOR A,R1	XOR A,R1	AND A,R1	OR A,R1	MOV R1,#d8	CMP R1,#d8	SETB dir: 1	BBS dir: 1,rel	INC R1	DEC R1	CALLV #1	BC rel
A	MOV A,R2	CMP A,R2	ADDC A,R2	SUBC A,R2	XOR A,R2	XOR A,R2	XOR A,R2	AND A,R2	OR A,R2	MOV R2,#d8	CMP R2,#d8	SETB dir: 2	BBS dir: 2,rel	INC R2	DEC R2	CALLV #2	BP rel
B	MOV A,R3	CMP A,R3	ADDC A,R3	SUBC A,R3	XOR A,R3	XOR A,R3	XOR A,R3	AND A,R3	OR A,R3	MOV R3,#d8	CMP R3,#d8	SETB dir: 3	BBS dir: 3,rel	INC R3	DEC R3	CALLV #3	BN rel
C	MOV A,R4	CMP A,R4	ADDC A,R4	SUBC A,R4	XOR A,R4	XOR A,R4	XOR A,R4	AND A,R4	OR A,R4	MOV R4,#d8	CMP R4,#d8	SETB dir: 4	BBS dir: 4,rel	INC R4	DEC R4	CALLV #4	BNZ rel
D	MOV A,R5	CMP A,R5	ADDC A,R5	SUBC A,R5	XOR A,R5	XOR A,R5	XOR A,R5	AND A,R5	OR A,R5	MOV R5,#d8	CMP R5,#d8	SETB dir: 5	BBS dir: 5,rel	INC R5	DEC R5	CALLV #5	BZ rel
E	MOV A,R6	CMP A,R6	ADDC A,R6	SUBC A,R6	XOR A,R6	XOR A,R6	XOR A,R6	AND A,R6	OR A,R6	MOV R6,#d8	CMP R6,#d8	SETB dir: 6	BBS dir: 6,rel	INC R6	DEC R6	CALLV #6	BGE rel
F	MOV A,R7	CMP A,R7	ADDC A,R7	SUBC A,R7	XOR A,R7	XOR A,R7	XOR A,R7	AND A,R7	OR A,R7	MOV R7,#d8	CMP R7,#d8	SETB dir: 7	BBS dir: 7,rel	INC R7	DEC R7	CALLV #7	BLT rel

■ MASK OPTIONS (MB89855R)

Option type	Option selection	Remarks
Power-on reset	0: Without power-on reset 1: With power-on reset	—
Initial value of oscillation stabilization delay time	0: $2^{18}/F_c$ (s) (Crystal oscillator) 1: $2^{14}/F_c$ (s) (Ceramic oscillator)	Selects the initial value of the OSCS bit in the STBC register during power-on reset.
Reset pin output	0: Without reset output 1: With reset output	—
Pull-up resistor at port pin P00 to P07, P10 to P17, P20 to P27, P30 to P37, P40 to P47, P60 to P64	1: Without pull-up resistor 0: With pull-up resistor	<ul style="list-style-type: none"> • Can be set per pin. • P00 to P07, P10 to P17, and P20 to P27 with a pull-up resistor can be set only for single-chip mode.

■ STANDARD OPTION LIST

Parameter	Part number	MB89P857/W857
Power-on reset		Available
Initial value of oscillation stabilization delay time		$2^{18}/F_c$ (s)
Output at reset pin		Available
Pull-up resistor at port pin		Not available

■ ORDERING INFORMATION

Part number	Package	Remarks
MB89855RP-SH MB89P857P-SH	64-pin Plastic SH-DIP (DIP-64P-M01)	
MB89W857C-SH	64-pin Ceramic SH-DIP (DIP-64C-A06)	ES level only
MB89W857CF-ES-BND	64-pin Ceramic QFP (FPT-64C-A02)	ES level only

MB89850R Series

■ PACKAGE DIMENSIONS

64-pin Plastic SH-DIP
(DIP-64P-M01)

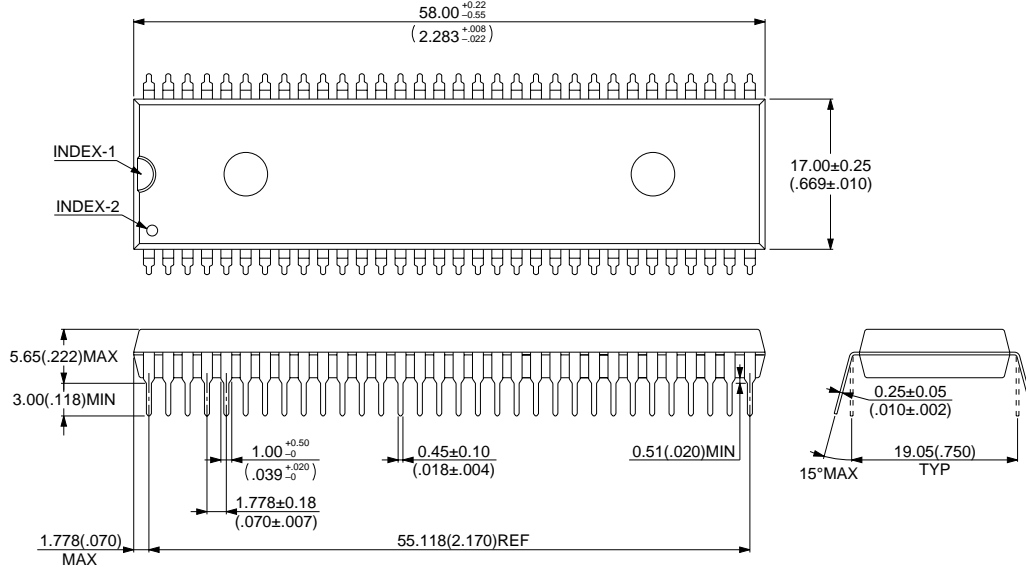

© 1994 FUJITSU LIMITED D64001S-3C-4

Dimensions in mm (inches)

64-pin Ceramic SH-DIP
(DIP-64C-A06)

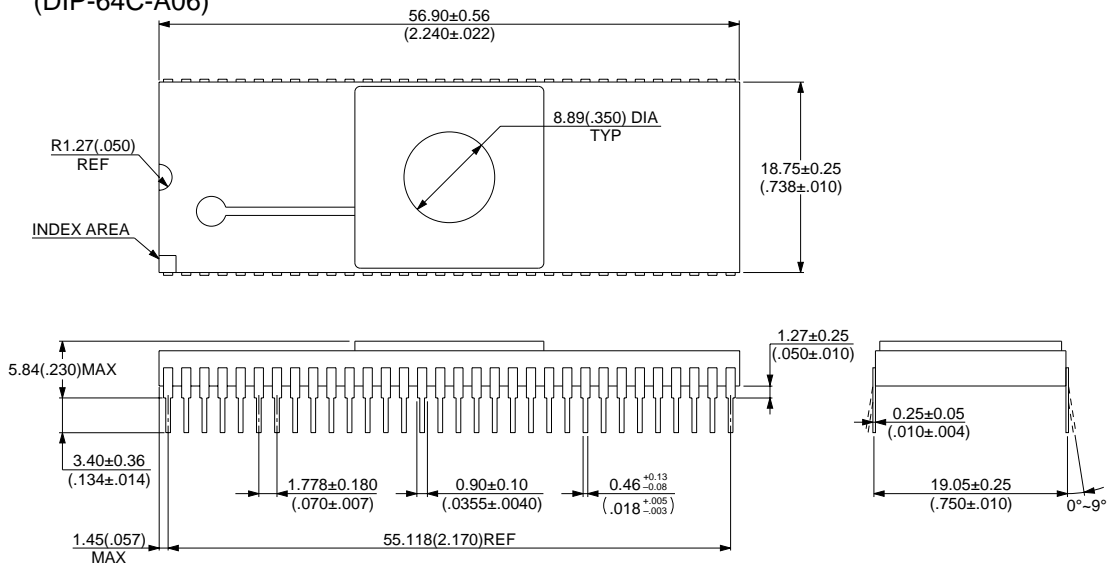

© 1994 FUJITSU LIMITED D64006SC-1-2

Dimensions in mm (inches)

64-pin Plastic QFP (FPT-64P-M06)

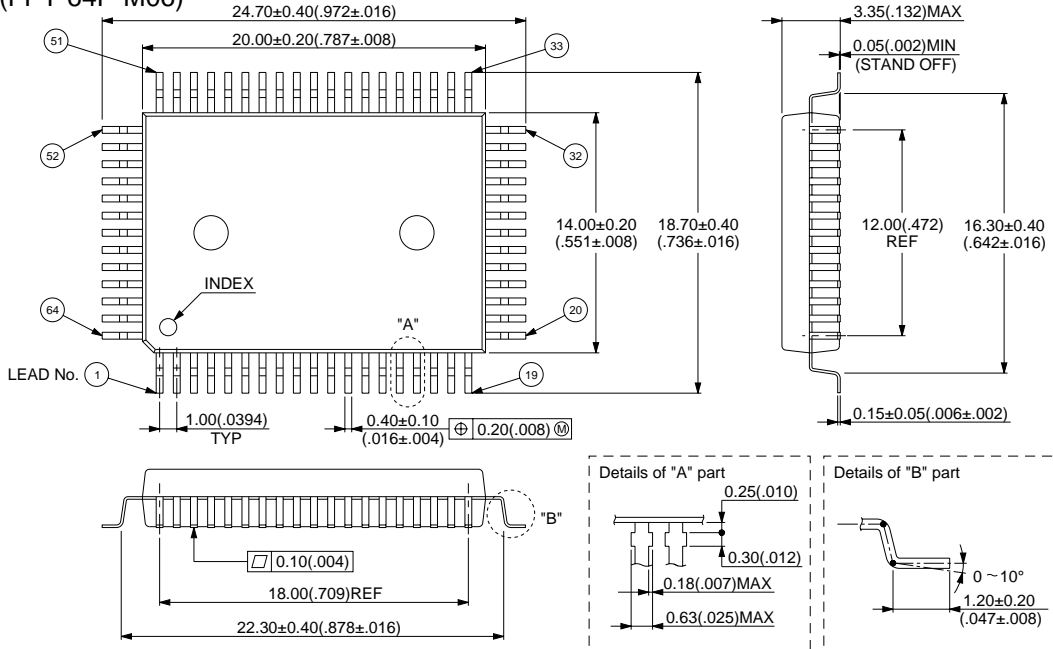

© 1994 FUJITSU LIMITED F64013S-3C-2

Dimensions in mm (inches)

64-pin Ceramic QFP (FPT-64C-A02)

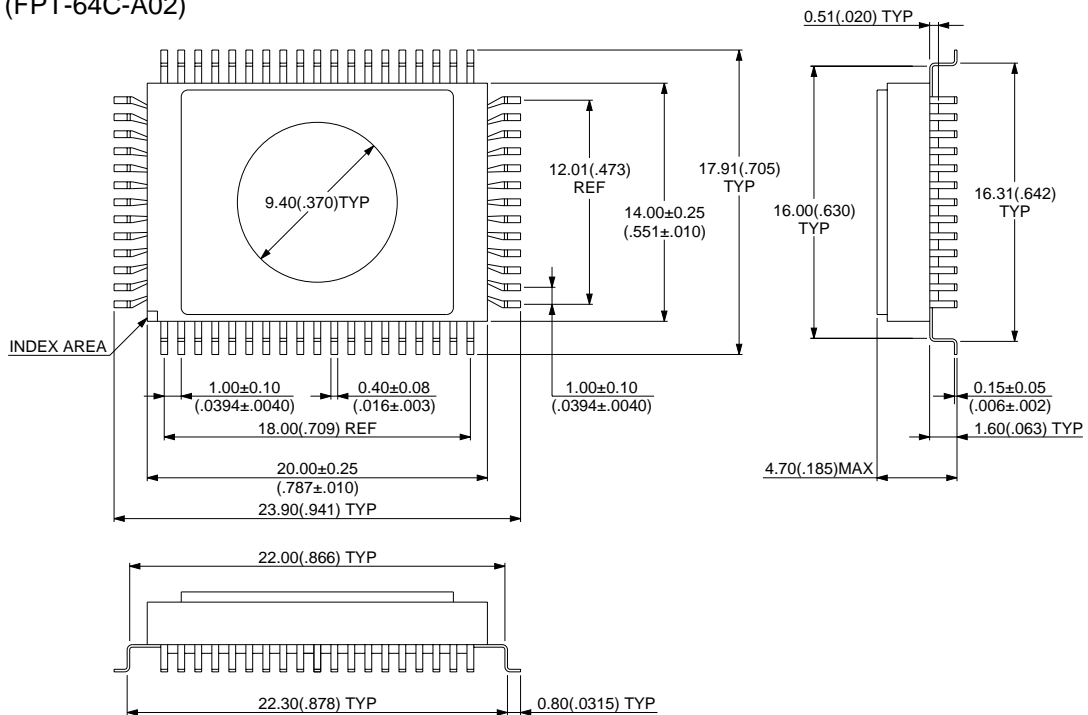

© 1994 FUJITSU LIMITED F64012SC-2-2

Dimensions in mm (inches)

MB89850R Series

FUJITSU LIMITED

For further information please contact:

Japan

FUJITSU LIMITED
Corporate Global Business Support Division
Electronic Devices
KAWASAKI PLANT, 4-1-1, Kamikodanaka,
Nakahara-ku, Kawasaki-shi,
Kanagawa 211-8588, Japan
Tel: +81-44-754-3763
Fax: +81-44-754-3329

<http://www.fujitsu.co.jp/>

North and South America

FUJITSU MICROELECTRONICS, INC.
3545 North First Street,
San Jose, CA 95134-1804, USA
Tel: +1-408-922-9000
Fax: +1-408-922-9179

Customer Response Center
Mon. - Fri.: 7 am - 5 pm (PST)
Tel: +1-800-866-8608
Fax: +1-408-922-9179

<http://www.fujitsumicro.com/>

Europe

FUJITSU MICROELECTRONICS EUROPE GmbH
Am Siebenstein 6-10,
D-63303 Dreieich-Buchsschlag,
Germany
Tel: +49-6103-690-0
Fax: +49-6103-690-122

<http://www.fujitsu-fme.com/>

Asia Pacific

FUJITSU MICROELECTRONICS ASIA PTE LTD
#05-08, 151 Lorong Chuan,
New Tech Park,
Singapore 556741
Tel: +65-281-0770
Fax: +65-281-0220

<http://www.fmap.com.sg/>

F9609

© FUJITSU LIMITED Printed in Japan

All Rights Reserved.

The contents of this document are subject to change without notice.

Customers are advised to consult with FUJITSU sales representatives before ordering.

The information and circuit diagrams in this document are presented as examples of semiconductor device applications, and are not intended to be incorporated in devices for actual use. Also, FUJITSU is unable to assume responsibility for infringement of any patent rights or other rights of third parties arising from the use of this information or circuit diagrams.

The contents of this document may not be reproduced or copied without the permission of FUJITSU LIMITED.

FUJITSU semiconductor devices are intended for use in standard applications (computers, office automation and other office equipments, industrial, communications, and measurement equipments, personal or household devices, etc.).

CAUTION:

Customers considering the use of our products in special applications where failure or abnormal operation may directly affect human lives or cause physical injury or property damage, or where extremely high levels of reliability are demanded (such as aerospace systems, atomic energy controls, sea floor repeaters, vehicle operating controls, medical devices for life support, etc.) are requested to consult with FUJITSU sales representatives before such use. The company will not be responsible for damages arising from such use without prior approval.

Any semiconductor devices have inherently a certain rate of failure. You must protect against injury, damage or loss from such failures by incorporating safety design measures into your facility and equipment such as redundancy, fire protection, and prevention of over-current levels and other abnormal operating conditions.

If any products described in this document represent goods or technologies subject to certain restrictions on export under the Foreign Exchange and Foreign Trade Control Law of Japan, the prior authorization by Japanese government should be required for export of those products from Japan.