

Differential Positive ECL (DPECL) SK-A29C0 Series

Description

The **SK-A29C0 Series** of quartz crystal oscillators provide DPECL Fast Edge compatible signals. This device is to operate using positive voltage and uses multiple ground pins for improved signal integrity. This device is intended to operate on positive voltage for PECL applications.

Features

- Wide frequency range - 60.0MHz to 350.0MHz
- User specified tolerance available
- Case at electrical ground
- Will withstand vapor phase temperatures of 253°C for 4 minutes maximum
- All metal, resistance weld, hermetically sealed package
- High shock resistance, to 1500g
- Low Jitter - Wavecrest jitter characterization available
- High Reliability - NEL HALT/HASS qualified for crystal oscillator start-up conditions
- High Q Crystal actively tuned oscillator circuit
- Power supply decoupling internal
- High frequencies due to proprietary design
- RoHS compliant, Lead-free construction

Electrical Connection

Pin	Connection
1	V _{CC}
2	V _{EE} Case
6	V _{EE} Case
7	Output
8	/Output
9	V _{EE} Case
13	V _{EE} Case
14	Enable/Disable

All other pins are
No Connect

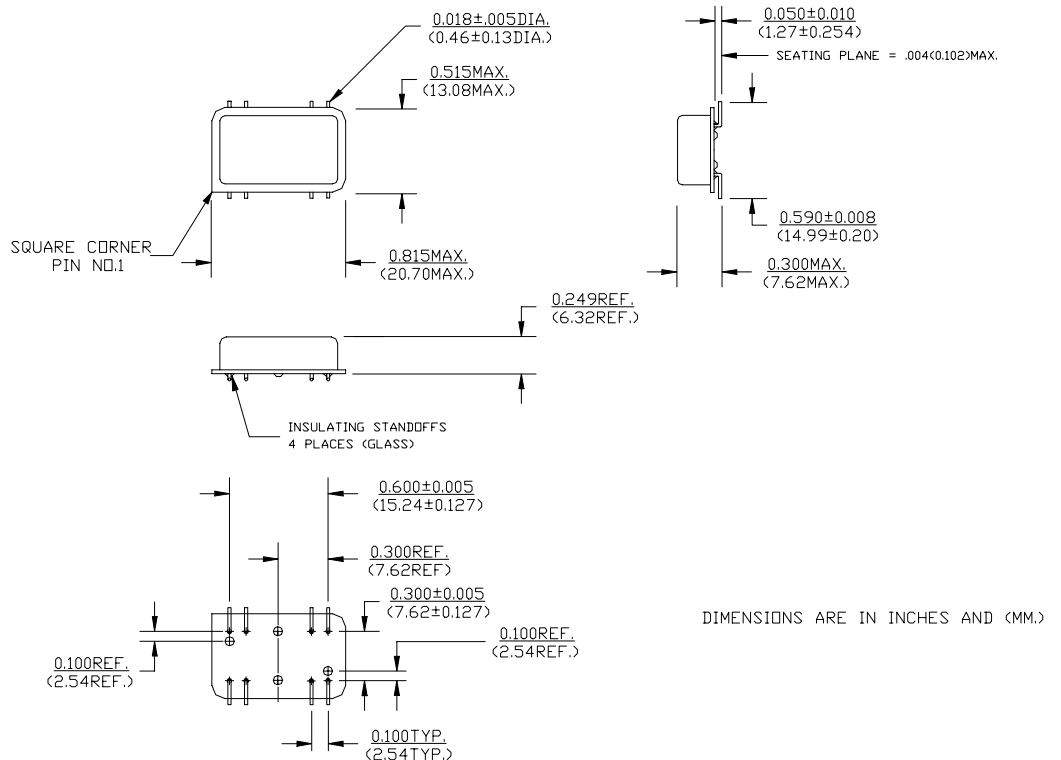

SK-A29C0 Series Continued
Differential Positive ECL (DPECL)

Rev. -

Operating Conditions and Output Characteristics

Electrical Characteristics

Parameter	Symbol	Conditions	Min	Typical	Max
Frequency	----	----	60.0MHz	----	350.0MHz
Duty Cycle	----	@ 50% points	48/52%	----	52/48%
Logic 0 ⁽¹⁾	V _{OL}	----	V _{CC} -1.810V	----	V _{CC} -1.620V
Logic 1 ⁽¹⁾	V _{OH}	----	V _{CC} -1.025V	----	V _{CC} -0.880V
Rise & Fall Time	tr,tf	20-80%V _O with 50 ohm load to V _{CC} -2V	----	350 psec	600 psec
Jitter, Cycle to Cycle	----	----	----	----	50 psec
Enable Voltage ⁽²⁾	----	with V _{EE} =0V	2.0V	----	----
Disable Voltage	----	with V _{EE} =0V	----	----	0.8V
Frequency Stability ⁽³⁾	dF/F	Overall conditions including: voltage, calibration, temp., 10 yr aging, shock, vibration	-100ppm	----	+100ppm

General Characteristics

Parameter	Symbol	Conditions	Min	Typical	Max
Supply Voltage	V _{CC}	----	3.135V	3.3V	3.465V
Supply Current	I _{CC}	50 ohm termination To 2.00V below V _{CC}	0.0 mA	----	50 mA
Output current	I _O	Low level Output Current	0.0 mA	----	±50.0 mA
Operating temperature	T _A	----	0°C	----	55°C
Storage temperature	T _S	----	-55°C	----	125°C
Input: Logic High (ECL) - Disables V _{EE} or Open - Enables					
Lead temperature	T _L	Soldering, 10 sec.	----	----	300°C
Load		50 Ohm to V _{CC} -2V or Thevenin Equivalent, Bias Required			
Start-up time	t _S	----	----	2 ms	10 ms

Environmental and Mechanical Characteristics

Mechanical Shock	Per MIL-STD-202, Method 213, Condition E
Thermal Shock	Per MIL-STD-833, Method 1011, Condition A
Vibration	0.060" double amplitude 10 Hz to 55 Hz, 35g's 55Hz to 2000 Hz
Soldering Condition	300°C for 10 seconds
Hermetic Seal	Leak rate less than 1 x 10 ⁻⁸ atm.cc/sec of helium

Footnotes:

- 1) V_{OL}, V_{OH}, referenced to ground
- 2) Open to Enable pin also enables the output.
- 3) Standard frequency stability (other available)

Creating a Part Number

SK - A29CX - FREQ

<p>Package Code</p> <p>HK Leaded 8 pin (14 pin)</p> <p>SK 8 pin (14 pin) SMD Gull Wing</p> <p>Input Voltage</p> <table border="0"> <tr> <td>Code</td> <td>Specification</td> </tr> <tr> <td>A</td> <td>3.3V</td> </tr> <tr> <td>B</td> <td>2.5V</td> </tr> </table>	Code	Specification	A	3.3V	B	2.5V	<p>Tolerance/Performance</p> <p>0 ±100ppm 0-70°C</p> <p>1 ±50ppm 0-70°C</p> <p>7 ±25ppm 0-70°C</p> <p>9 Customer Specific</p> <p>A ±20ppm 0-70°C</p> <p>B ±50ppm -40 to +85°C</p> <p>C ±100ppm -40 to +85°C</p>
Code	Specification						
A	3.3V						
B	2.5V						

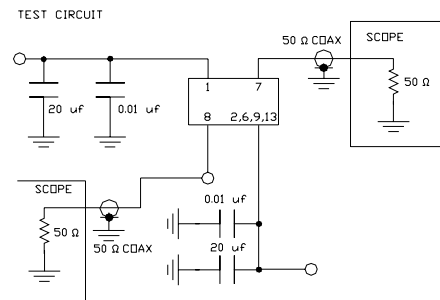

TEST CIRCUIT USES A SPLIT SUPPLY OF +2V AND -1.3V FOR EASE OF TESTING.