



Free Mount Cylinder

A space-saving air cylinder with multiple surfaces capable of mounting directly. Offered in rich variations.



Space-saving

The multiple surface direct mounting with a square body and no brackets allows the freedom of the mounting surface. This enables space-saving designs for equipment.

Auto Switch Capable

Mounting

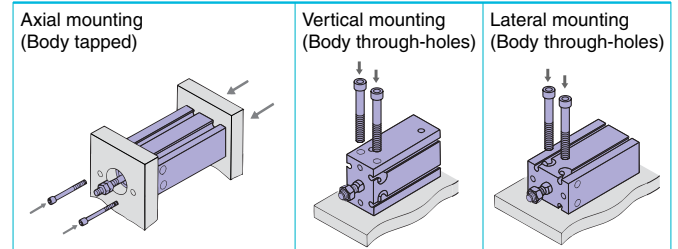

Series Variations

Series	Action	Rod	Bore size(mm)	Page	
Standard Series CU	Double acting	Single rod	6, 10, 16, 20, 25, 32	2	
	Single acting	Double rod		8	
Non-rotating Series CUK	Double acting	Single rod (Retracted/Extended)		13	
	Single acting	Single rod		21	
Long stroke Series CU	Double acting	Double rod		25	
	Single acting	Single rod (Retracted/Extended)		29	
Long stroke, Non-rotating rod Series CUK	Double acting	Single rod		35	
	Double acting	Single rod		39	
With air cushion Series CU-A	Double acting	Single rod		20, 25, 32	46
For vacuum Series ZCUK	Double acting	Single rod		10, 16, 20, 25, 32	55

Made to Order

- XB6 : Heat resistant (150°C)
- XB7 : Cold resistant (-40°C)
- XB9 : Low speed (10 to 50 mm/s)
- XB13 : Low speed (5 to 50 mm/s)
- XC19 : Intermediate stroke (with a spacer built-in)
- XC22 : Seals made of fluorine rubber
- XC34 : Non-rotating plate
(No protrusion from the rod end)

P. 43

Related Products

- Copper/Fluorine-free: Series **20-**

P. 4, 23, 37

- Clean Series: Series **10/11-**
- Copper/Fluorine/Silicon-based free
+ Low particle generation: Series **21/22-**
- Low speed: Series **CUX**

P. 45

Series CU

Precautions on Free Mount

1. Operating speed

Make sure to connect a speed controller to the cylinder and adjust its speed to 500 mm/s or less.

If a load is to be attached to the end of the rod, adjust the speed to the maximum speed shown in Graph (1) or less, in accordance with the added mass.

Graph (1) Load Weight and Maximum Speed

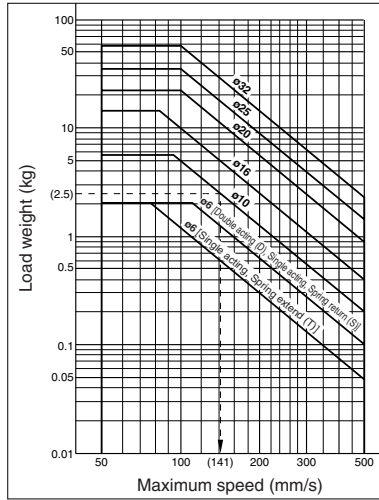

How to read the graph

- Using the CU10 to drive a load weighing 2.5 kg: From the vertical axis in the graph on the left, extend the horizontally from 2.5 kg., and drop down from the point at which it intersects with the tube bore ø10. The maximum speed will be 141 mm/s.

2. Rod end allowable lateral load

Make sure that the lateral load that is applied to the rod end will be no more than the values shown in the tables.

The tables show the value for a single rod. For double rods, please contact SMC.

Standard Double Acting, Single Rod

Without auto switch: CU□-□D

(N)

Model	Stroke (mm)												
	5	10	15	20	25	30	40	50	60	70	80	90	100
CU6	0.085	0.075	0.068	0.061	0.056	0.052	0.045	0.039	0.035	—	—	—	—
CU10	0.34	0.30	0.27	0.25	0.23	0.21	0.18	0.16	0.15	—	—	—	—
CU16	0.69	0.61	0.55	0.50	0.46	0.43	0.37	0.33	0.29	—	—	—	—
CU20	2.2	2.0	1.8	1.6	1.5	1.4	1.2	1.1	1.0	0.92	0.85	0.78	0.73
CU25	3.5	3.2	3.0	2.7	2.6	2.4	2.1	1.9	1.7	1.6	1.4	1.3	1.2
CU32	5.4	4.9	4.6	4.3	4.0	3.8	3.3	3.0	2.8	2.5	2.3	2.2	2.0

With auto switch: CDU□-□D

(N)

Model	Stroke (mm)												
	5	10	15	20	25	30	40	50	60	70	80	90	100
CDU6	0.085	0.075	0.068	0.061	0.056	0.052	0.045	0.039	0.035	—	—	—	—
CDU10	0.34	0.30	0.27	0.25	0.23	0.21	0.18	0.16	0.15	—	—	—	—
CDU16	0.99	0.89	0.81	0.74	0.69	0.64	0.56	0.50	0.45	—	—	—	—
CDU20	3.0	2.7	2.5	2.3	2.1	2.0	1.8	1.6	1.4	1.3	1.2	1.1	1.0
CDU25	4.7	4.3	4.0	3.7	3.5	3.2	2.9	2.6	2.4	2.2	2.0	1.9	1.7
CDU32	7.1	6.6	6.1	5.7	5.4	5.1	4.6	4.1	3.8	3.5	3.2	3.0	2.8

Non-rotating Rod Type

Without auto switch: CUK□-□D

(N)

Model	Stroke (mm)												
	5	10	15	20	25	30	40	50	60	70	80	90	100
CUK6	0.075	0.068	0.061	0.056	0.052	0.048	0.042	0.037	0.033	—	—	—	—
CUK10	0.30	0.27	0.25	0.23	0.21	0.20	0.17	0.15	0.14	—	—	—	—
CUK16	0.55	0.50	0.46	0.43	0.40	0.37	0.33	0.29	0.26	—	—	—	—
CUK20	1.8	1.6	1.5	1.4	1.3	1.2	1.1	1.0	0.92	0.85	0.78	0.73	0.68
CUK25	3.0	2.7	2.6	2.4	2.2	2.1	1.9	1.7	1.6	1.4	1.3	1.2	1.2
CUK32	4.3	4.0	3.8	3.5	3.3	3.2	2.9	2.6	2.4	2.2	2.1	2.0	1.8

With auto switch: CDUK□-□D

(N)

Model	Stroke (mm)												
	5	10	15	20	25	30	40	50	60	70	80	90	100
CDUK6	0.075	0.068	0.061	0.056	0.052	0.048	0.042	0.037	0.033	—	—	—	—
CDUK10	0.30	0.27	0.25	0.23	0.21	0.20	0.17	0.15	0.14	—	—	—	—
CDUK16	0.81	0.74	0.69	0.64	0.60	0.56	0.50	0.45	0.41	—	—	—	—
CDUK20	2.5	2.3	2.1	2.0	1.9	1.8	1.6	1.4	1.3	1.2	1.1	1.0	1.0
CDUK25	4.0	3.7	3.5	3.2	3.1	2.9	2.6	2.4	2.2	2.0	1.9	1.7	1.6
CDUK32	5.7	5.4	5.1	4.8	4.6	4.4	4.0	3.6	3.4	3.1	2.9	2.7	2.6

Single Acting, Spring Return (S)

Without auto switch: CU□-□S (N)

Model	Stroke (mm)		
	5	10	15
CU6	0.19	0.17	0.15
CU10	0.66	0.59	0.60
CU16	1.4	1.3	1.3
CU20	4.7	4.2	4.4
CU25	6.8	6.2	6.5
CU32	10	9.8	10

With auto switch: CDU□-□S (N)

Model	Stroke (mm)		
	5	10	15
CDU6	0.17	0.15	0.13
CDU10	0.66	0.59	0.60
CDU16	1.6	1.5	1.5
CDU20	5.3	4.8	4.9
CDU25	7.6	7.0	7.2
CDU32	12	11	11

Non-rotating Rod Type Single Acting, Spring Return (S)

Without auto switch: CUK□-□S (N)

Model	Stroke (mm)		
	5	10	15
CUK6	0.17	0.15	0.14
CUK10	0.59	0.54	0.56
CUK16	1.1	1.0	1.1
CUK20	3.9	3.6	3.8
CUK25	5.7	5.3	5.7
CUK32	8.5	7.9	8.6

With auto switch: CDUK□-□S (N)

Model	Stroke (mm)		
	5	10	15
CDUK6	0.15	0.13	0.12
CDUK10	0.59	0.54	0.56
CDUK16	1.3	1.2	1.3
CDUK20	4.4	4.1	4.3
CDUK25	6.5	6.1	6.4
CDUK32	9.7	9.1	9.6

Single Acting, Spring Extend (T)

Without auto switch: CU□-□T (N)

Model	Stroke (mm)		
	5	10	15
CU6	0.067	0.059	0.052
CU10	0.29	0.26	0.24
CU16	0.99	0.89	0.81
CU20	2.2	2.0	1.8
CU25	3.5	3.2	3.0
CU32	5.4	4.9	4.6

With auto switch: CDU□-□T (N)

Model	Stroke (mm)		
	5	10	15
CDU6	0.062	0.055	0.049
CDU10	0.29	0.26	0.24
CDU16	0.99	0.89	0.81
CDU20	3.0	2.7	2.5
CDU25	4.7	4.3	4.0
CDU32	7.1	6.6	6.1

Non-rotating Rod Type Single Acting, Spring Extend (T)

Without auto switch: CUK□-□T (N)

Model	Stroke (mm)		
	5	10	15
CUK6	0.059	0.052	0.047
CUK10	0.26	0.24	0.22
CUK16	0.81	0.74	0.69
CUK20	1.8	1.6	1.5
CUK25	3.0	2.7	2.6
CUK32	4.3	4.0	3.8

With auto switch: CDUK□-□T (N)

Model	Stroke (mm)		
	5	10	15
CDUK6	0.055	0.049	0.044
CDUK10	0.26	0.24	0.22
CDUK16	0.81	0.74	0.69
CDUK20	2.5	2.3	2.1
CDUK25	4.0	3.7	3.5
CDUK32	5.7	5.4	5.1

Free Mount Cylinder Double Acting, Single Rod Series CU

ø6, ø10, ø16, ø20, ø25, ø32



How to Order

Without auto switch CU 6 [] 30 D

With auto switch CDU 6 [] 30 D M9B []

Built-in magnet

Bore size

6	6 mm
10	10 mm
16	16 mm
20	20 mm
25	25 mm
32	32 mm

Port thread type

Symbol	Type	Bore size
Nil	M5 x 0.8	ø6, ø10, ø16, ø20, ø25
	Rc1/8	ø32
TN	NPT1/8	ø32
TF	G1/8	ø32

Number of auto switches

Nil	2 pcs.
S	1 pc.

Auto switch

Nil	Without auto switch
-----	---------------------

* Refer to the table below for applicable auto switches.
* Auto switches are shipped together but not assembled.

Action

D	Double acting
---	---------------

Standard stroke (mm)

ø6, ø10, ø16	5, 10, 15, 20, 25, 30
ø20, ø25, ø32	5, 10, 15, 20, 25, 30, 40, 50

Applicable Auto Switches/Refer to page P.68 to 72 for further information on auto switches.

Type	Special function	Electrical entry	Indicator light	Wiring (Output)	Load voltage			Auto switch model		Lead wire length (m)*			Pre-wired connector	Applicable load	
					DC	AC	Perpendicular	In-line	0.5 (Nil)	3 (L)	5 (Z)	Applicable load			
												IC circuit		Relay, PLC	
Reed switch	—	Grommet	Yes	3-wire (NPN equivalent)	—	5 V	—	A96V	A96	●	●	—	—	IC circuit	—
				2-wire	24V	12 V	100 V	A93V	A93	●	●	—	—	IC circuit	Relay, PLC
Solid state switch	Diagnostic indication (2-color indication)	Grommet	Yes	3-wire (NPN)	24V	5 V, 12 V	—	M9NV	M9N	●	●	○	○	IC circuit	Relay, PLC
				3-wire (PNP)				M9PV	M9P	●	●	○	○		
				2-wire				M9BV	M9B	●	●	○	○	—	
				3-wire (NPN)				F9NWV	F9NW	●	●	○	○	IC circuit	
				3-wire (PNP)				F9PWV	F9PW	●	●	○	○	IC circuit	
				2-wire				F9BWV	F9BW	●	●	○	○	—	

* Lead wire length symbols: 0.5 m.....Nil (Example) M9N
3 m.....L (Example) M9NL
5 m.....Z (Example) M9NZ

* Solid state switches marked with "○" are produced upon receipt of order.

* Normally closed (NC=b contact), solid states switches (Model D-F9G, F9H) are also available. For detail, refer to page 7-9-23 in Best Pneumatics 2004 Vol. 7 catalog.

* For detail about auto switches with pre-wired connector, refer to page 7-9-36 in the Best Pneumatics 2004 Vol. 7 catalog.

Series CU



JIS Symbol

Double acting,
Single rod

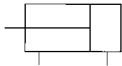

Made to Order Specifications (For details, refer to P.43.)

Symbol	Specifications
-XB6	Heat resistant (150°C)
-XB7	Cold resistant (-40°C)
-XB9	Low speed (10 to 50 mm/s)
-XB13	Low speed (5 to 50 mm/s)
-XC19	Intermediate stroke (with a spacer built-in)
-XC22	Seals made of fluorine rubber

Refer to "Pneumatic Clean Series" catalog for clean room specifications.

Tightening Torque

When mounting Series CU, refer to the below table.

Bore size (mm)	Hexagon socket head cap screw dia. (mm)	Proper tightening torque (N·m)
6, 10	M3	1.08 ±10%
16	M4	2.45 ±10%
20, 25	M5	5.10 ±10%
32	M6	8.04 ±10%

Specifications

Bore size (mm)	6	10	16	20	25	32
Fluid	Air					
Proof pressure	1.05 MPa					
Maximum operating pressure	0.7 MPa					
Minimum operating pressure	0.12 MPa	0.06 MPa	0.05 MPa			
Ambient and fluid temperature	Without auto switch: -10 to 70°C (No freezing) With auto switch: -10 to 60°C (No freezing)					
Lubrication	Non-lube					
Piston speed	50 to 500 mm/s					
Cushion	Rubber bumper					
Rod end thread	Male thread					
Thread tolerance	JIS Class 2					
Stroke length tolerance	+1.0 0 mm					

Standard Stroke

Bore size (mm)	Standard stroke (mm)
6, 10, 16	5, 10, 15, 20, 25, 30
20, 25, 32	5, 10, 15, 20, 25, 30, 40, 50

For "Long Stroke", refer to P. 36.

Minimum Stroke for Auto Switch Mounting

No. of auto switches mounted	Applicable auto switch		
	D-A9□, D-A9□V	D-M9□, D-M9□V	D-F9□W, D-F9□WV
1 pc.	5	5	5
2 pcs.	10	5	10

Theoretical Output

Bore size (mm)	Rod size (mm)	Operating direction	Piston area (mm ²)	Operating pressure (MPa)		
				0.3	0.5	0.7
6	3	OUT	28.3	8.49	14.2	19.8
		IN	21.2	6.36	10.6	14.8
10	4	OUT	78.5	23.6	39.3	55.0
		IN	66.0	19.8	33.0	46.2
16	6	OUT	201	60.3	101	141
		IN	172	51.6	86.0	121
20	8	OUT	314	94.2	157	220
		IN	264	79.2	132	185
25	10	OUT	491	147	246	344
		IN	412	124	206	288
32	12	OUT	804	241	402	563
		IN	691	207	346	454

Weight/(): Denotes the values with D-A93.

Model	Cylinder stroke (mm)							
	5	10	15	20	25	30	40	50
C(D)U6-□D	22 (27)	25 (35)	28 (38)	31 (41)	34 (44)	37 (47)	—	—
C(D)U10-□D	36 (41)	40 (50)	44 (54)	48 (58)	52 (62)	56 (66)	—	—
C(D)U16-□D	50 (75)	56 (86)	62 (92)	68 (98)	74 (104)	80 (110)	—	—
C(D)U20-□D	95 (128)	106 (143)	117 (154)	128 (165)	139 (176)	150 (187)	172 (209)	194 (231)
C(D)U25-□D	176 (230)	193 (252)	210 (269)	227 (286)	244 (303)	261 (320)	295 (354)	329 (388)
C(D)U32-□D	262 (335)	286 (364)	310 (388)	334 (412)	358 (436)	382 (460)	430 (508)	478 (556)

* For the auto switch weight, refer to P.68 to 72.

Copper-free

20-CU **Bore size** — **Stroke** D

• **Copper-free**

The type which prevents copper based ions from generating by changing the copper based materials into electroless nickel plated treatment or non-copper materials in order to eliminate the effects by copper based ions or fluororesins over the color cathode ray tube.

Minimum Operating Pressure (MPa)

Bore size (mm)	6	10, 16	20, 25, 32
Minimum operating pressure	0.12	0.06	0.05

Specifications

Action	Double acting, Single rod
Bore size (mm)	6, 10, 16, 20, 25, 32
Maximum operating pressure	1.05 MPa
Cushion	Rubber bumper
Stroke	Same as standard type (Refer to page 2.)
Auto switch	Mountable

Construction

ø6

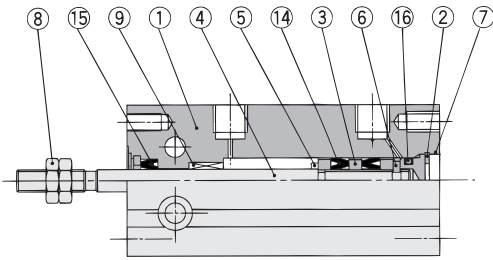

With auto switch

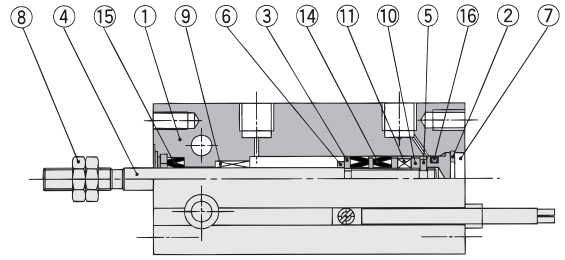

ø10

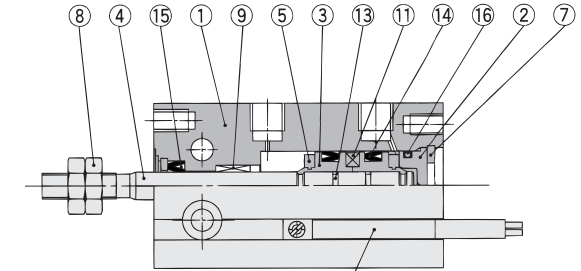
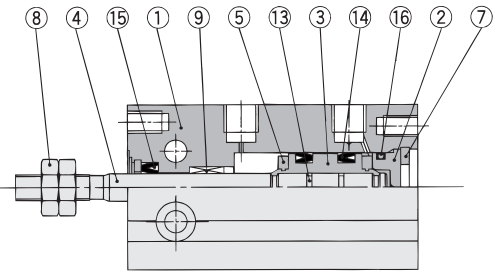

ø16 to ø32

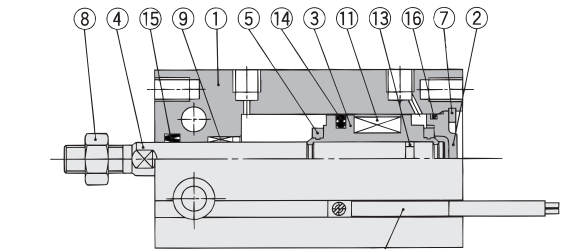
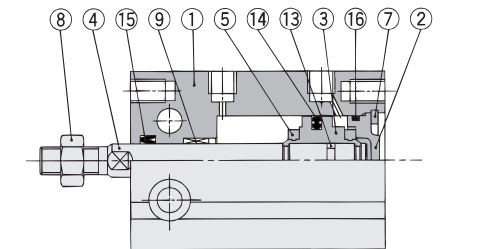

Component Parts

No.	Description	Material	Note
1	Cylinder tube	Aluminum alloy	Hard anodized
2	Head cover	Brass	ø6 to ø10, Electroless nickel plated
		Aluminum alloy	ø16 to ø32, Clear chromated
3	Piston	Brass	ø6 to ø10
		Aluminum alloy	ø16 to ø32, Chromated
4	Piston rod	Stainless steel	
5	Bumper A	Urethane	
6	Bumper B	Urethane	
7	Snap ring	Carbon tool steel	Phosphate coated

Component Parts

No.	Description	Material	Note
8	Rod end nut	Carbon steel	Nickel plated
9	Bushing	Oil-impregnated sintered alloy	
10	Magnet holder	Brass	ø6
11	Magnet	Magnetic material	
12	Auto switch	—	
13	Piston gasket	NBR	
14*	Piston seal		
15*	Rod seal		
16*	Gasket		

Replacement Parts: Seal Kit

Bore size (mm)	Kit no.	Contents
10	CU10D-PS	Set of nos. above 14, 15, 16
16	CU16D-PS	
20	CU20D-PS	
25	CU25D-PS	
32	CU32D-PS	

* Seal kit includes 14, 15, 16. Order the seal kit, based on each bore size.

Series CU

Dimensions: Double Acting, Single Rod

ø6, ø10

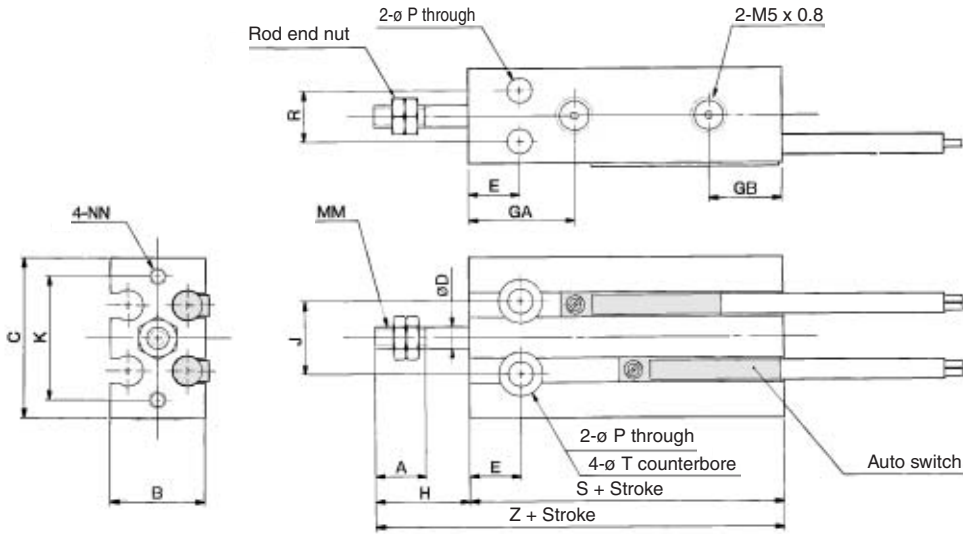

ø16 to ø32

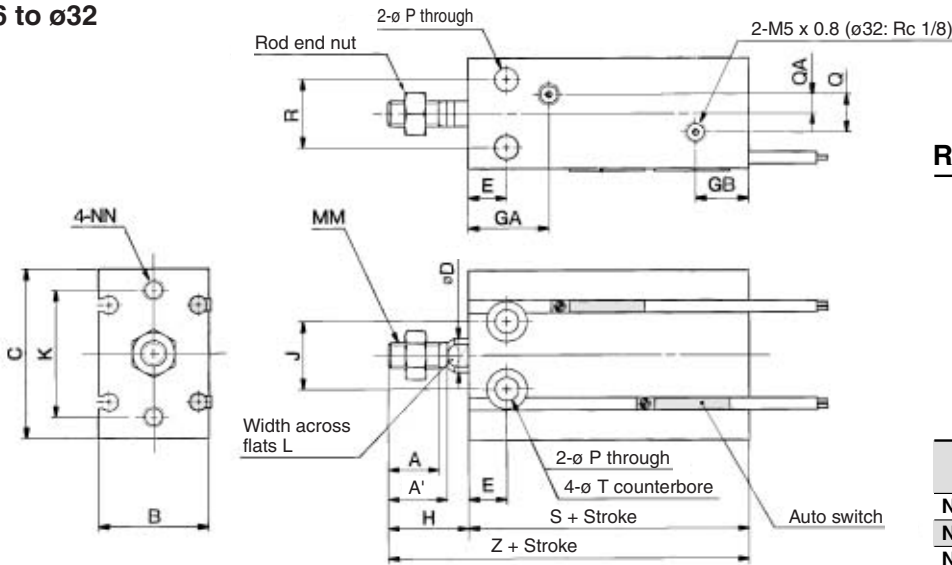

Rod End Nut/Accessory

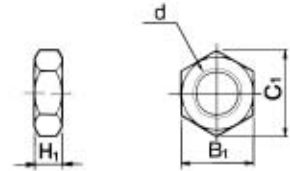

Material: Carbon steel

Part no.	Applicable bore (mm)	d	H ₁	B ₁	C ₁
NTP-006	6	M3 x 0.5	1.8	5.5	6.4
NTP-010	10	M4 x 0.7	2.4	7	8.1
NTJ-015A	16	M5 x 0.8	4	8	9.2
NT-015A	20	M6 x 1.0	5	10	11.5
NT-02	25	M8 x 1.25	5	13	15.0
NT-03	32	M10 x 1.25	6	17	19.6

Bore size (mm)	A	A'	B	C	D	E	GA	GB	H	J	K	L	MM	NN	P	Q	QA
6	7	—	13	22	3	7	15	10	13	10	17	—	M3 x 0.5	M3 x 0.5 depth 5	3.2	—	—
10	10	—	15	24	4	7	16.5	10	16	11	18	—	M4 x 0.7	M3 x 0.5 depth 5	3.2	—	—
16	11	12.5	20	32	6	7	16.5 ^(Note)	11.5	16	14	25	5	M5 x 0.8	M4 x 0.7 depth 6	4.5	4	2
20	12	14	26	40	8	9	19	12.5	19	16	30	6	M6 x 1.0	M5 x 0.8 depth 8	5.5	9	4.5
25	15.5	18	32	50	10	10	21.5	13	23	20	38	8	M8 x 1.25	M5 x 0.8 depth 8	5.5	9	4.5
32	19.5	22	40	62	12	11	23	12.5	27	24	48	10	M10 x 1.25	M6 x 1.0 depth 9	6.6	13.5	4.5

Note) 5 stroke (CU16-5D): 14.5 mm

Bore size (mm)	R	T	Without auto switch		With auto switch	
			S	Z	S	Z
6	7	6 depth 4.8	33	46	33	46
10	9	6 depth 5	36	52	36	52
16	12	7.6 depth 6.5	30	46	40	56
20	16	9.3 depth 8	36	55	46	65
25	20	9.3 depth 9	40	63	50	73
32	24	11 depth 11.5	42	69	52	79

Proper Auto Switch Mounting Position (Detection at stroke end) and Its Mounting Height

D-A9□
D-M9□
D-F9□W

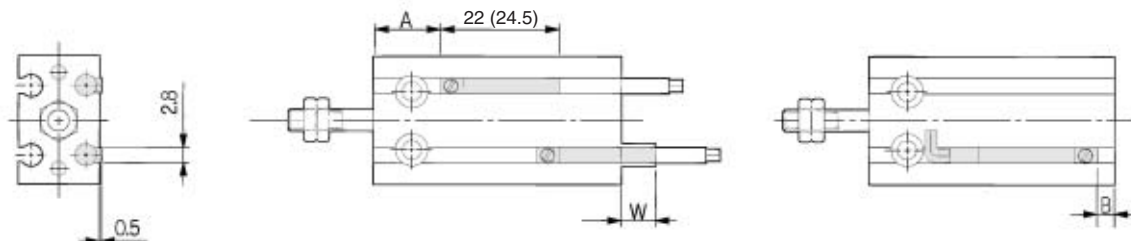

() : Denotes the values of D-A93.

D-A9□V
D-M9□V
D-F9□WV

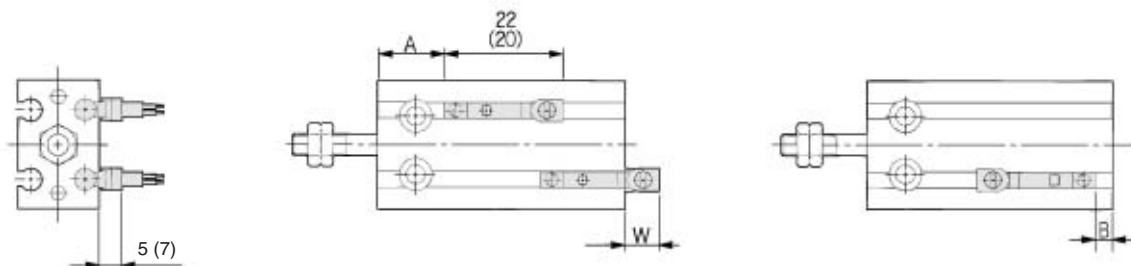

() : Denotes the values of D-M9□V, D-F9□WV.

CDU Double Acting, Single Rod

Bore size (mm)	D-A9□, D-A9□V			D-M9□, D-F9□W			D-M9□V, D-F9□WV		
	A	B	W	A	B	W	A	B	W
6	13.5	-0.5	2.5(5)	17.5	3.5	6.5	17.5	3.5	4.5
10	12.5	3.5	-1.5(1)	16.5	7.5	2.5	16.5	7.5	0.5
16	16	4	-2(0.5)	20	8	1.5	20	8	-0.5
20	20	6	-4(-1.5)	24	10	0	24	10	-2
25	22.5	7	-5.5(-3)	26.5	11	-1.5	26.5	11	-3.5
32	23.5	8.5	-6.5(-4)	27.5	12.5	-2.5	27.5	12.5	-4.5



Note 1) Figures in the table above are used as a reference when mounting the auto switches for stroke end detection. In the case of actually setting the auto switches, adjust them after confirming their operation.

Note 2) Negative figures in the table W indicate an auto switch is mounted inward from the edge of the cylinder body.

Note 3) In the case of the 5 stroke or the 10 stroke, there are times in which the switch will not turn OFF or 2 switches will turn ON simultaneously due to their movement range. Therefore, set the position approximately 1 to 4 mm outward from the values given in the table above. Then, perform an operation inspection to make sure that the switches operate normally (if 1 switch is used, make sure that it turns ON and OFF properly; if 2 switches are used, make sure that both switches turn ON).

Note 4) () in column W is the dimensions of D-A93.

Operating Range

Auto switch model	Bore size (mm)					
	6	10	16	20	25	32
D-A9□/A9□V	5	6	9	11	12.5	14
D-M9□/M9□V	2.5	2.5	3.5	5	5	5
D-F9□W/F9□WV	3	3.5	5.5	6.5	7	7

* Since this is a guideline including hysteresis, not meant to be guaranteed.
(assuming approximately ±30% dispersion.)

There may be the case it will vary substantially depending on an ambient environment.

Series CU

Mounting of Auto Switch

D-A9□/M9□/A9□V/M9□V/F9□W/F9□WV

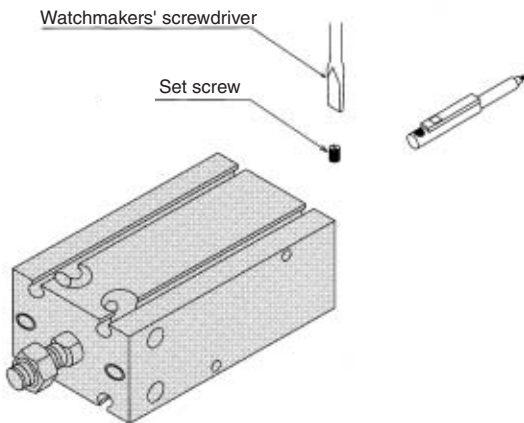

- When tightening an auto switch mounting screw, use a watchmakers' screwdriver with a grip diameter of 5 to 6 mm.
- Use a tightening torque of approximately 0.10 to 0.20 N·m.

Auto Switch Groove

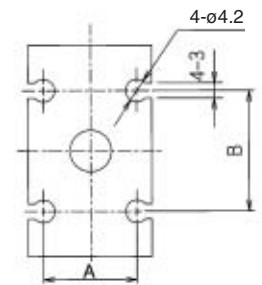

Bore size (mm)	A	B
6	8.2	9
10	10.3	13
16	15	18
20	21	23
25	27	25
32	35	27

Caution on Proximity Installation

When free mounting cylinders equipped with auto switches are used, the auto switches could activate unintentionally if the installed distance is less than the dimensions shown in the table. Therefore, make sure to provide a greater clearance. Due to unavoidable circumstances, if they must be used with less distance than the dimensions given in the table, the cylinders must be shielded. Therefore, affix a steel plate or a magnetic shield plate (MU-S025) to the area on the cylinder that corresponds to the adjacent auto switch. (Please contact SMC for details.) Auto switches may malfunction if a shield plate is not used.

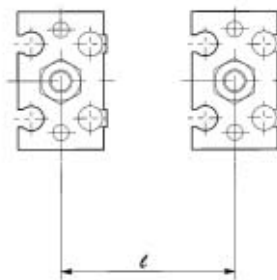

Bore size (mm)	Mounting pitch l (mm)
6	18
10	20
16	33
20	40
25	46
32	56

Free Mount Cylinder Double Acting, Double Rod Series **CUW** ø6, ø10, ø16, ø20, ø25, ø32



How to Order

Without auto switch

CUW **6** **30** **D**

With auto switch

CDUW **6** **30** **D** **M9B**

Built-in magnet

Double rod

Bore size

6	6 mm
10	10 mm
16	16 mm
20	20 mm
25	25 mm
32	32 mm

Port thread type

Symbol	Type	Bore size
Nil	M5 x 0.8	ø6, ø10, ø16, ø20, ø25
	Rc1/8	ø32
TN	NPT1/8	ø32
TF	G1/8	ø32

Number of auto switches

Nil	2 pcs.
S	1 pc.

Auto switch

Nil	Without auto switch
-----	---------------------

* Refer to the table below for applicable auto switches.
* Auto switches are shipped together but not assembled.

Action

D	Double acting
---	---------------

Standard stroke (mm)

ø6, ø10, ø16	5, 10, 15, 20, 25, 30, 40, 50, 60
ø20, ø25, ø32	5, 10, 15, 20, 25, 30, 40, 50, 60, 70, 80, 90, 100

Applicable Auto Switches/Refer to page 68 to 72 for further information on auto switches.

Type	Special function	Electrical entry	Indicator light	Wiring (Output)	Load voltage		Auto switch model		Lead wire length (m)*			Pre-wired connector	Applicable load		
					DC	AC	Perpendicular	In-line	0.5 (Nil)	3 (L)	5 (Z)		IC circuit	Relay, PLC	
Reed switch	—	Grommet	Yes	3-wire (NPN equivalent)	—	5 V	—	A96V	A96	●	●	—	—	IC circuit	—
				2-wire	24 V	12 V	100 V	A93V	A93	●	●	—	—	—	—
Solid state switch	Diagnostic indication (2-color indication)	Grommet	Yes	3-wire (NPN)	24 V	5 V, 12 V	—	M9NV	M9N	●	●	○	○	IC circuit	Relay, PLC
				3-wire (PNP)				M9PV	M9P	●	●	○	○	IC circuit	
				2-wire				M9BV	M9B	●	●	○	○	—	
				3-wire (NPN)				F9NWV	F9NW	●	●	○	○	IC circuit	
				3-wire (PNP)				F9PVV	F9PW	●	●	○	○	IC circuit	
				2-wire				F9BWW	F9BW	●	●	○	○	—	

* Lead wire length symbols: 0.5 m.....Nil (Example) M9N
3 m.....L (Example) M9NL
5 m.....Z (Example) M9NZ

* Solid state switches marked with "○" are produced upon receipt of order.

* Normally closed (NC=b contact), solid states switches (Model D-F9G, F9H) are also available. For detail, refer to page 7-9-23 in Best Pneumatics 2004 Vol. 7 catalog.

* For detail about auto switches with pre-wired connector, refer to page 7-9-36 in the Best Pneumatics 2004 Vol. 7 catalog.

Series CUW



Specifications

Bore size (mm)	6	10	16	20	25	32
Fluid	Air					
Proof pressure	1.05 MPa					
Maximum operating pressure	0.7 MPa					
Minimum operating pressure	0.15 MPa	0.10 MPa	0.08 MPa			
Ambient and fluid temperature	Without auto switch: -10 to 70°C (No freezing) With auto switch: -10 to 60°C (No freezing)					
Lubrication	Non-lube					
Piston speed	50 to 500 mm/s					
Cushion	Rubber bumper					
Rod end thread	Male thread					
Thread tolerance	JIS Class 2					
Stroke length tolerance	$^{+1.0}_0$ mm					

Standard Stroke

Bore size (mm)	Standard stroke (mm)
6, 10, 16	5, 10, 15, 20, 25, 30, 40, 50, 60
20, 25, 32	5, 10, 15, 20, 25, 30, 40, 50, 60, 70, 80, 90, 100

Minimum Stroke for Auto Switch Mounting

(mm)

No. of auto switches mounted	Applicable auto switch		
	D-A9□, D-A9□V	D-M9□, D-M9□V	D-F9□W, D-F9□WV
1 pc.	5	5	5
2 pcs.	10	5	10

JIS Symbol

Double acting,
Double rod



Theoretical Output

(N)

Bore size (mm)	Rod size (mm)	Piston area (mm ²)	Operating pressure (MPa)		
			0.3	0.5	0.7
6	3	21.2	6.36	10.6	14.8
10	4	66.0	19.8	33.0	46.2
16	6	172	51.6	86.0	121
20	8	264	79.2	132	185
25	10	412	124	206	288
32	12	691	207	346	484

Weight/(): Denotes the values with D-A93.

(g)

Model	Stroke (mm)												
	5	10	15	20	25	30	40	50	60	70	80	90	100
C(D)UW6-□D	27 (32)	30 (40)	34 (44)	37 (47)	40 (50)	44 (54)	51 (61)	58 (68)	65 (75)	—	—	—	—
C(D)UW10-□D	44 (49)	49 (59)	53 (63)	58 (68)	62 (72)	67 (77)	76 (86)	85 (95)	94 (104)	—	—	—	—
C(D)UW16-□D	74 (99)	81 (111)	88 (118)	95 (125)	102 (132)	109 (139)	123 (153)	137 (167)	151 (181)	—	—	—	—
C(D)UW20-□D	132 (165)	145 (182)	158 (195)	171 (208)	184 (221)	197 (234)	223 (260)	250 (287)	275 (312)	301 (338)	327 (364)	353 (390)	379 (416)
C(D)UW25-□D	240 (294)	260 (319)	280 (339)	300 (359)	321 (380)	341 (400)	381 (440)	421 (480)	461 (520)	501 (560)	541 (600)	581 (640)	621 (680)
C(D)UW32-□D	365 (438)	394 (472)	422 (500)	451 (529)	479 (557)	508 (586)	586 (664)	622 (700)	679 (757)	736 (814)	793 (871)	850 (928)	907 (985)

* For the auto switch weight, refer to page 68 to 72.

Tightening Torque

When mounting Series CUW, refer to page 3.

Construction

ø6

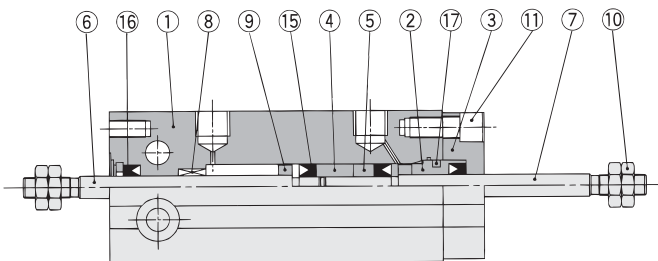

With auto switch

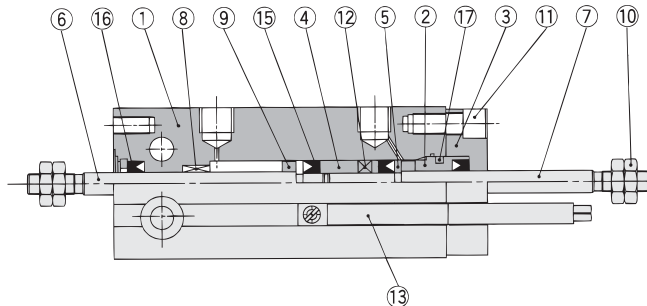

ø10

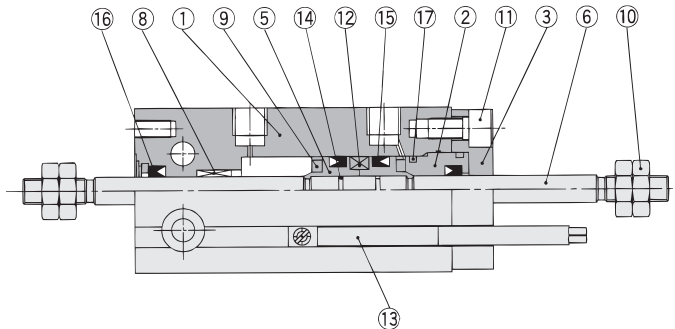
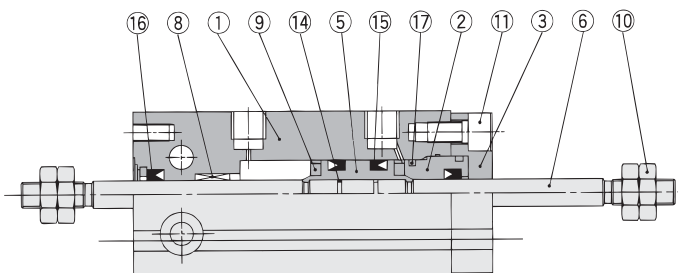

ø16 to 32

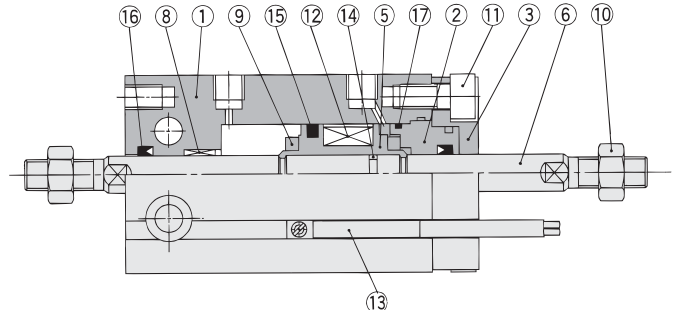
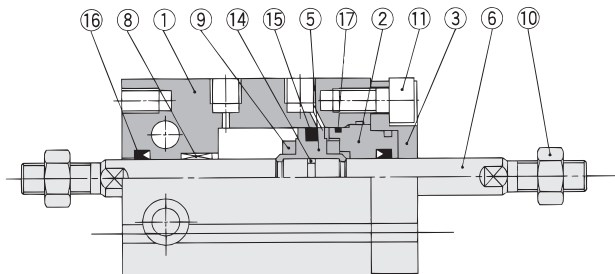

Component Parts

No.	Description	Material	Note
1	Cylinder tube	Aluminum alloy	Hard anodized
2	Rod cover	Aluminum bearing alloy	Chromated
3	Rod cover retainer	Aluminum alloy	Hard anodized
4	Piston	Brass	ø6
5	Piston	Brass	ø6, ø10
		Aluminum alloy	ø16 to ø32, Chromated
6	Piston rod	Stainless steel	
7	Piston rod	Stainless steel	ø6
8	Bushing	Oil-impregnated sintered alloy	

Component Parts

No.	Description	Material	Note
9	Bumper	Urethane	
10	Rod end nut	Carbon steel	Nickel plated
11	Hexagon socket head cap screw	Carbon steel	Nickel plated
12	Magnet	Magnetic material	
13	Auto switch	—	
14	Piston gasket	NBR	
15*	Piston seal		
16*	Rod seal		
17*	Gasket		

Replacement Parts: Seal Kit

Kit no.	Bore size (mm) / Part no.				
	10	16	20	25	32
	CUW10D-PS	CUW16D-PS	CUW20D-PS	CUW25D-PS	CUW32D-PS

* Seal kit includes 15, 16, 17. Order the seal kit, based on each bore size.

Series CU

Dimensions: Double Acting, Double Rod

ø6, ø10

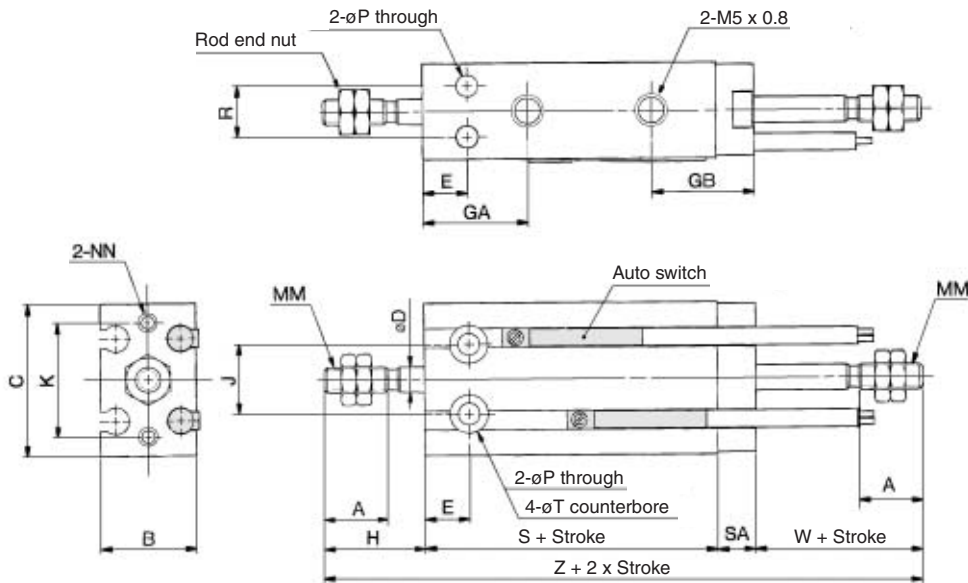

ø16 to ø32

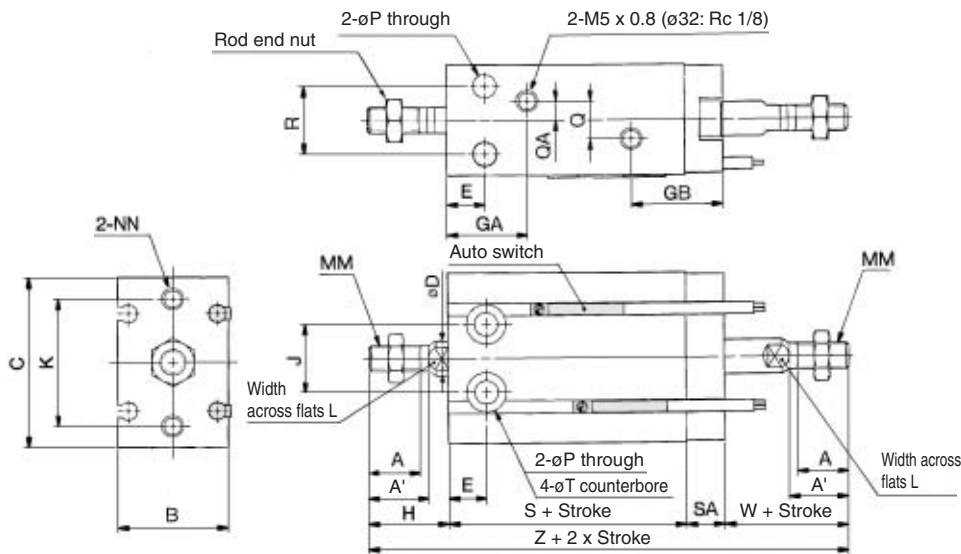

Rod End Nut/Accessory

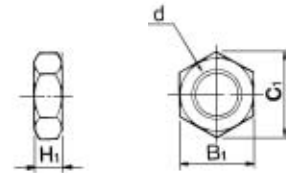

Material: Carbon steel

Part no.	Applicable bore size (mm)	d	H ₁	B ₁	C ₁
NTP-006	6	M3 x 0.5	1.8	5.5	6.4
NTP-010	10	M4 x 0.7	2.4	7	8.1
NTJ-015A	16	M5 x 0.8	4	8	9.2
NT-015A	20	M6 x 1.0	5	10	11.5
NT-02	25	M8 x 1.25	5	13	15.0
NT-03	32	M10 x 1.25	6	17	19.6

Bore size (mm)	A	A'	B	C	D	E	GA	GB	H	J	K	L	MM	NN	P	Q	QA
6	7	—	13	22	3	7	15	16	13	10	17	—	M3 x 0.5	M3 x 0.5 depth 5	3.2	—	—
10	10	—	15	24	4	7	16.5	16	16	11	18	—	M4 x 0.7	M3 x 0.5 depth 5	3.2	—	—
16	11	12.5	20	32	6	7	16.5 ^{Note)}	19	16	14	25	5	M5 x 0.8	M4 x 0.7 depth 6	4.5	4	2
20	12	14	26	40	8	9	19	21.5	19	16	30	6	M6 x 1.0	M5 x 0.8 depth 8	5.5	9	4.5
25	15.5	18	32	50	10	10	21.5	22	23	20	38	8	M8 x 1.25	M5 x 0.8 depth 8	5.5	9	4.5
32	19.5	22	40	62	12	11	23	22.5	27	24	48	10	M10 x 1.25	M6 x 1.0 depth 9	6.6	13.5	4.5

Note) 5 stroke (CUW16-5D): GA = 14.5

Bore size (mm)	R	SA	T	W	Without auto switch		With auto switch	
					S	Z	S	Z
6	7	6	6 depth 4.8	13	38	70	38	70
10	9	6	6 depth 5	16	36	74	36	74
16	12	7.5	7.6 depth 6.5	16	30	69.5	40	79.5
20	16	9	9.3 depth 8	19	36	83	46	93
25	20	9	9.3 depth 9	23	40	95	50	105
32	24	10	11 depth 11.5	27	42	106	52	116

Proper Auto Switch Mounting Position (Detection at stroke end) and Its Mounting Height

D-A9□
D-M9□
D-F9□W

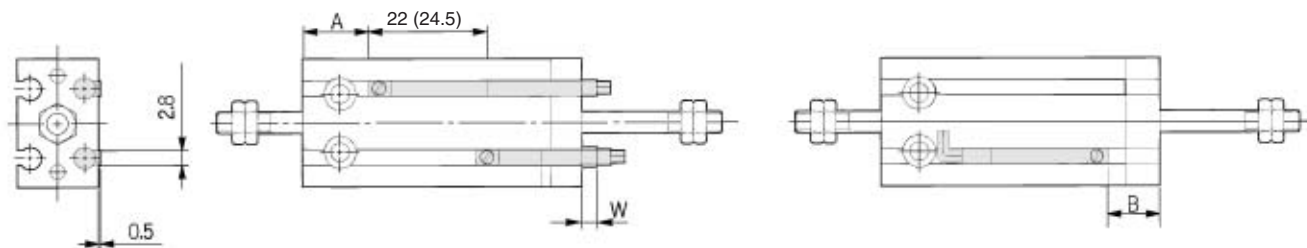

() : Denotes the values of D-A93.

D-A9□V
D-M9□V
D-F9□WV

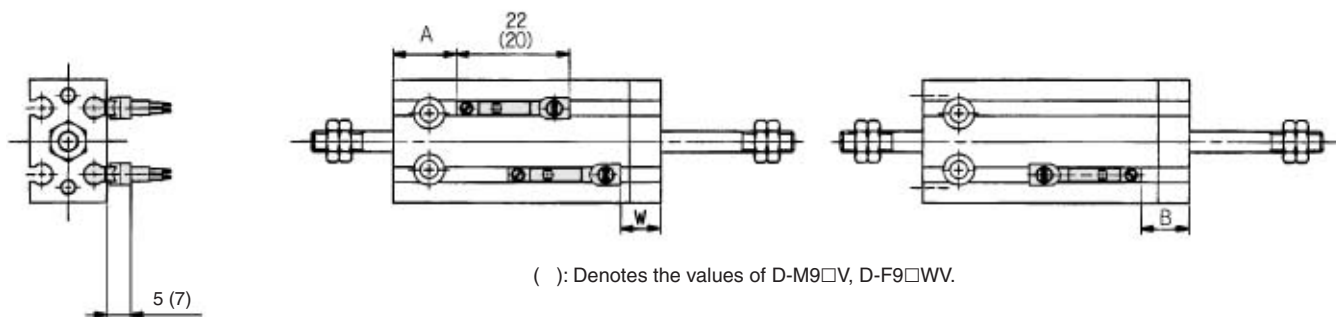

() : Denotes the values of D-M9□V, D-F9□WV.

Bore size (mm)	D-A9□, D-A9□V			D-M9□, D-F9□W			D-M9□V, D-F9□WV		
	A	B	W	A	B	W	A	B	W
6	13.5	5.5	-3.5(-1)	17.5	9.5	0.5	17.5	9.5	-1.5
10	12.5	9.5	-7.5(-5)	16.5	13.5	-3.5	16.5	13.5	-5.5
16	16	11.5	-9.5(-7)	20	15.5	5.5	20	15.5	-7.5
20	20	15	-13(-10.5)	24	19	-9	24	19	-11
25	22.5	16	-14.5(-12)	26.5	20	-10.5	26.5	20	-12.5
32	23.5	18.5	-16.5(-14)	27.5	22.5	-12.5	27.5	22.5	-14.5



Note 1) Figures in the table above are used as a reference when mounting the auto switches for stroke end detection. In the case of actually setting the auto switches, adjust them after confirming their operation.

Note 2) Negative figures in the table W indicate an auto switch is mounted inward from the edge of the cylinder body.

Note 3) In the case of the 5 stroke or the 10 stroke, there are times in which the switch will not turn OFF or 2 switches will turn ON simultaneously due to their movement range. Therefore, set the position approximately 1 to 4 mm outward from the values given in the table above. Then, perform an operation inspection to make sure that the switches operate normally (if 1 switch is used, make sure that it turns ON and OFF properly; if 2 switches are used, make sure that both switches turn ON).

Note 4) () in column W is the dimensions of D-A93.

Free Mount Cylinder

Single Acting, Single Rod, Spring Return/Extend

Series CU

ø6, ø10, ø16, ø20, ø25, ø32



How to Order

Without auto switch

CU 10 15 S

With auto switch

CDU 10 15 S M9B

Built-in magnet

Bore size

6	6 mm
10	10 mm
16	16 mm
20	20 mm
25	25 mm
32	32 mm

Port thread type

Symbol	Type	Bore size
Nil	M5 x 0.8	ø6, ø10, ø16, ø20, ø25
	Rc1/8	ø32
TN	NPT1/8	ø32
TF	G1/8	ø32

Number of auto switches

Nil	2 pcs.
S	1 pc.

Auto switch

Nil	Without auto switch
-----	---------------------

* Refer to the table below for applicable auto switches.
* Auto switches are shipped together but not assembled.

Action

S	Single acting, Spring return
T	Single acting, Spring extend

Standard stroke (mm)

ø6, ø10, ø16	5, 10, 15
ø20, ø25, ø32	

Applicable Auto Switches/Refer to page 68 to 72 for further information on auto switches.

Type	Special function	Electrical entry	Indicator light	Wiring (Output)	Load voltage		Auto switch model		Lead wire length (m)*			Pre-wired connector	Applicable load		
					DC	AC	Perpendicular	In-line	0.5 (Nil)	3 (L)	5 (Z)		Applicable load		
													IC circuit	Relay, PLC	
Reed switch	—	Grommet	Yes	3-wire (NPN equivalent)	—	5 V	—	A96V	A96	●	●	—	—	IC circuit	—
				2-wire	24 V	12 V	100 V	A93V	A93	●	●	—	—	—	Relay, PLC
Solid state switch	Diagnostic indication (2-color indication)	Grommet	No	3-wire (NPN)	24 V	5 V, 12 V	100 V or less	M9NV	M9N	●	●	○	○	IC circuit	Relay, PLC
				3-wire (PNP)				M9PV	M9P	●	●	○	○	IC circuit	
				2-wire	M9BV	M9B	●	●	○	○	—	—			
				3-wire (NPN)	F9NWV	F9NW	●	●	○	○	IC circuit				
				3-wire (PNP)	F9PWV	F9PW	●	●	○	○	IC circuit				
				2-wire	F9BWV	F9BW	●	●	○	○	—	—			

* Lead wire length symbols: 0.5 m.....Nil (Example) M9N
3 m.....L (Example) M9NL
5 m.....Z (Example) M9NZ

* Solid state switches marked with "○" are produced upon receipt of order.

* Normally closed (NC=b contact), solid states switches (Model D-F9G, F9H) are also available. For detail, refer to page 7-9-23 in Best Pneumatics 2004 Vol. 7 catalog.
* For detail about auto switches with pre-wired connector, refer to page 7-9-36 in the Best Pneumatics 2004 Vol. 7 catalog.

Free Mount Cylinder Single Acting, Single Rod, Spring Return/Extend **Series CU**



JIS Symbol

Single acting,
Spring return

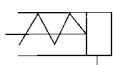

Single acting,
Spring extend

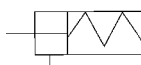

Specifications

Bore size (mm)	6	10	16	20	25	32
Fluid	Air					
Proof pressure	1.05 MPa					
Maximum operating pressure	0.7 MPa					
Minimum operating pressure	0.2 MPa	0.15 MPa	0.13 MPa			
Ambient and fluid temperature	Without auto switch: -10 to 70°C (No freezing) With auto switch: -10 to 60°C (No freezing)					
Lubrication	Non-lube					
Piston speed	50 to 500 mm/s					
Cushion	Rubber bumper ^{Note)}					
Rod end thread	Male thread					
Thread tolerance	JIS Class 2					
Stroke length tolerance	+ ⁰ / ₀ mm					

Note) ø6 with auto switch type: One side rubber bumper

Standard Stroke

Bore size (mm)	Standard stroke (mm)
6, 10, 16, 20, 25, 32	5, 10, 15

Minimum Stroke for Auto Switch Mounting

(mm)

No. of auto switches mounted	Applicable auto switch		
	D-A9□, D-A9□V	D-M9□, D-M9□V	D-F9□W, D-F9□WV
1 pc.	5	5	5
2 pcs.	10	5	10



Made to Order Specifications (For details, refer to page 43.)

Symbol	Specifications
-XC22	Seals made of fluorine rubber

Theoretical Output

(N)

Action	Bore size (mm)	Operating pressure (MPa)		
		0.3	0.5	0.7
Spring return (S)	ø6	4.99	10.7	16.3
	ø10	16.7	32.4	48.1
	ø16	45.6	86.3	126
	ø20	73	136	199
	ø25	119	218	316
	ø32	207	368	529
Spring extend (T)	ø6	2.86	7.10	11.3
	ø10	12.9	26.1	39.3
	ø16	37.2	71.8	106
	ø20	58	111	164
	ø25	95	178	260
	ø32	173	312	450

For the reactive force of spring return, refer to page 7-12-3 in Best Pneumatics 2004 Vol. 7 catalog.

Weight/(): Denotes the values with D-A93.

(g)

Model	Stroke (mm)		
	5	10	15
C(D)U6-□S,T	22(27)	25(35)	28(38)
C(D)U10-□S,T	36(41)	40(50)	48(58)
C(D)U16-□S,T	50(75)	56(86)	71(101)
C(D)U20-□S,T	95(128)	106(143)	133(170)
C(D)U25-□S,T	176(230)	193(252)	235(294)
C(D)U32-□S,T	262(335)	286(364)	347(425)

* For the weight of auto switch, refer to page 68 to 72.

Tightening Torque

When mounting a CU single acting series, refer to page 3.

Series CU

Construction

Single acting, Spring return

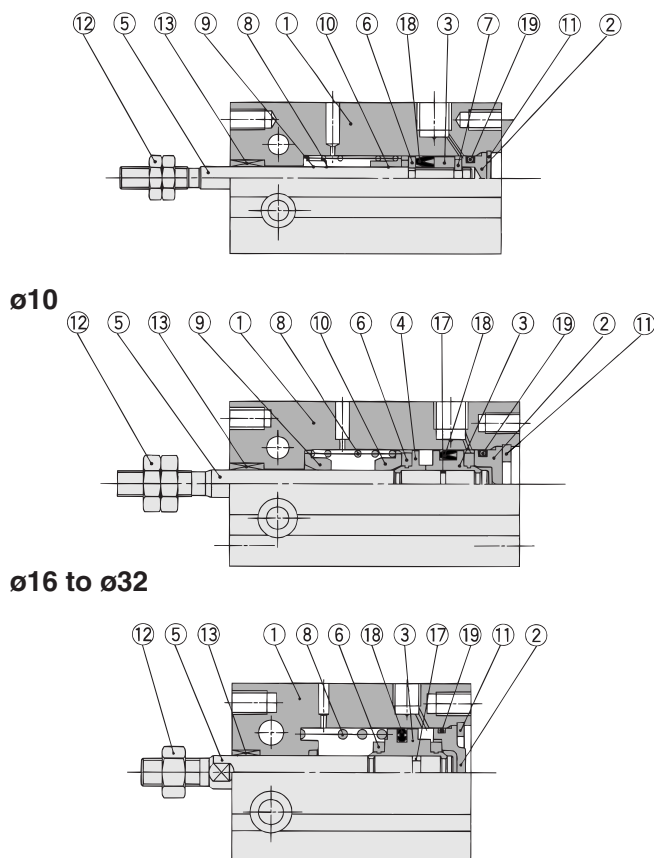

With auto switch

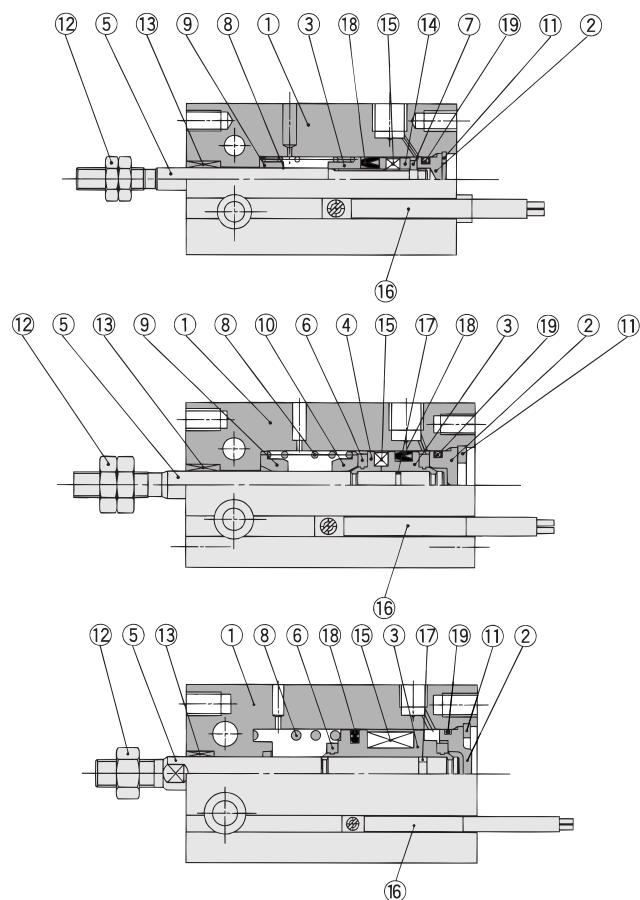

Component Parts

No.	Description	Material	Note
1	Cylinder tube	Aluminum alloy	Hard anodized
2	Head cover	Brass	ø6 to ø10, Electroless nickel plated
		Aluminum alloy	ø16 to ø32, Clear chromated
3	Piston	Brass	ø6 to ø10
		Aluminum alloy	ø16 to ø32, Chromated
4	Piston	Brass	ø10
5	Piston rod	Stainless steel	
6	Bumper A	Urethane	
7	Bumper B	Urethane	
8	Return spring	Piano wire	Zinc chromated

Component Parts

No.	Description	Material	Note
9	Spring seat	Brass	
10	Spring seat	Brass	
11	Snap ring	Carbon tool steel	Phosphate coated
12	Rod end nut	Carbon steel	Nickel plated
13	Bushing	Oil-impregnated sintered alloy	
14	Magnet holder	Brass	ø6
15	Magnet	Magnetic material	
16	Auto switch	—	
17	Piston gasket	NBR	
18*	Piston seal		
19*	Gasket		

Replacement Parts: Seal Kit

Kit no.	Bore size (mm) / Part no.				
	10	16	20	25	32
	CU10S-PS	CU16S-PS	CU20S-PS	CU25S-PS	CU32S-PS



* Seal kit includes 18, 19. Order the seal kit, based on each bore size.

Construction

Single acting, Spring extend

With auto switch

ø6

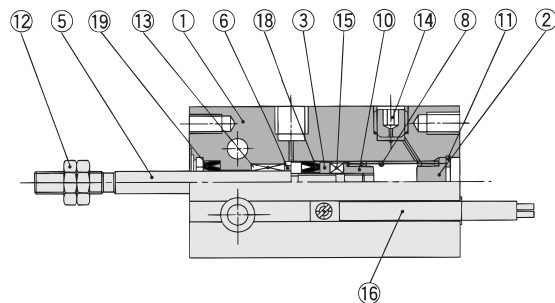
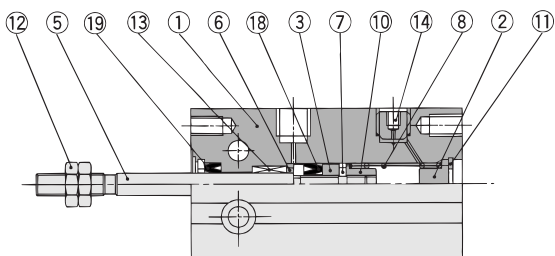

ø10

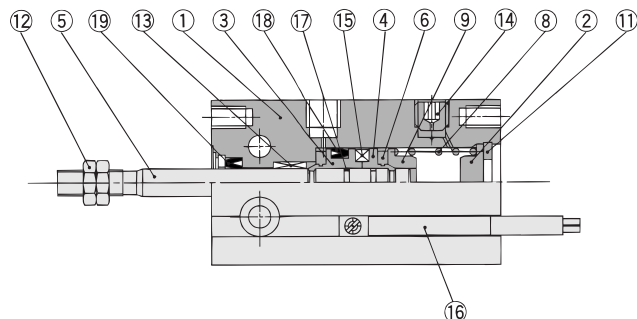
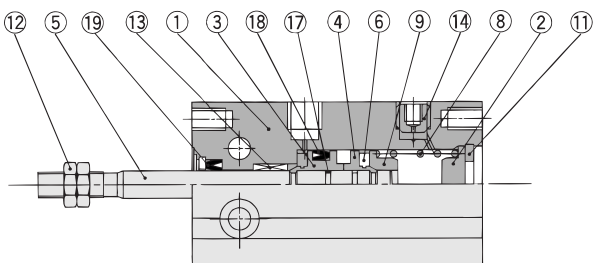

ø16 to ø32

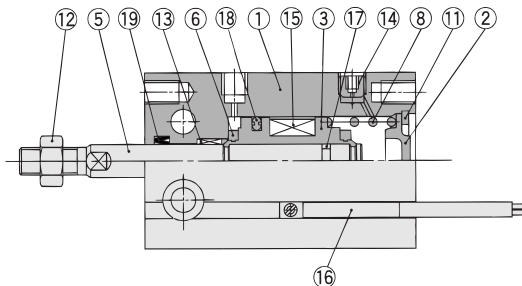
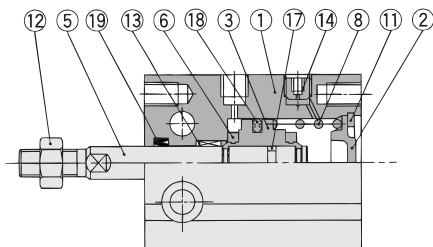

Component Parts

No.	Description	Material	Note
1	Cylinder tube	Aluminum alloy	Hard anodized
2	Head cover	Brass	ø6 to ø10, Electroless nickel plated
		Aluminum alloy	ø16 to ø32, Clear chromated
3	Piston	Brass	ø6 to ø10
		Aluminum alloy	ø16 to ø32, Chromated
4	Piston	Brass	ø10
5	Piston rod	Stainless steel	
6	Bumper A	Urethane	
7	Bumper B	Urethane	
8	Return spring	Piano wire	Zinc chromated

Component Parts

No.	Description	Material	Note
9	Spring seat	Brass	
10	Stopper	Brass	ø6
11	Snap ring	Carbon tool steel	Phosphate coated
12	Rod end nut	Carbon steel	Nickel plated
13	Bushing	Oil-impregnated sintered alloy	
14	Plug with fixed orifice	Alloy steel	Black zinc chromated
15	Magnet	Magnetic material	
16	Auto switch	—	
17	Piston gasket	NBR	
18*	Piston seal		
19*	Rod seal		

Replacement Parts: Seal Kit

Kit no.	Bore size (mm) / Part no.				
	10	16	20	25	32
	CU10T-PS	CU16T-PS	CU20T-PS	CU25T-PS	CU32T-PS

* Seal kit includes 18, 19. Order the seal kit, based on each bore size.

Series CU

Dimensions: Single Acting, Spring Return

ø6, ø10

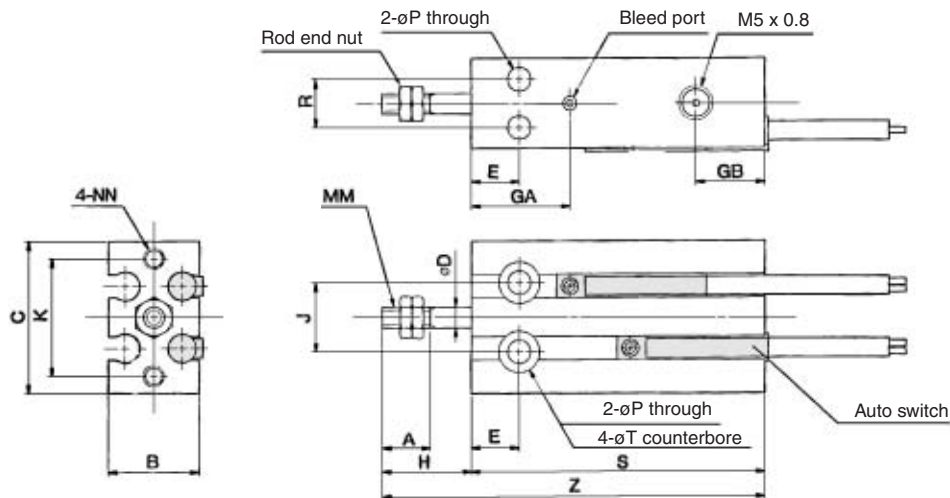

ø16 to ø32

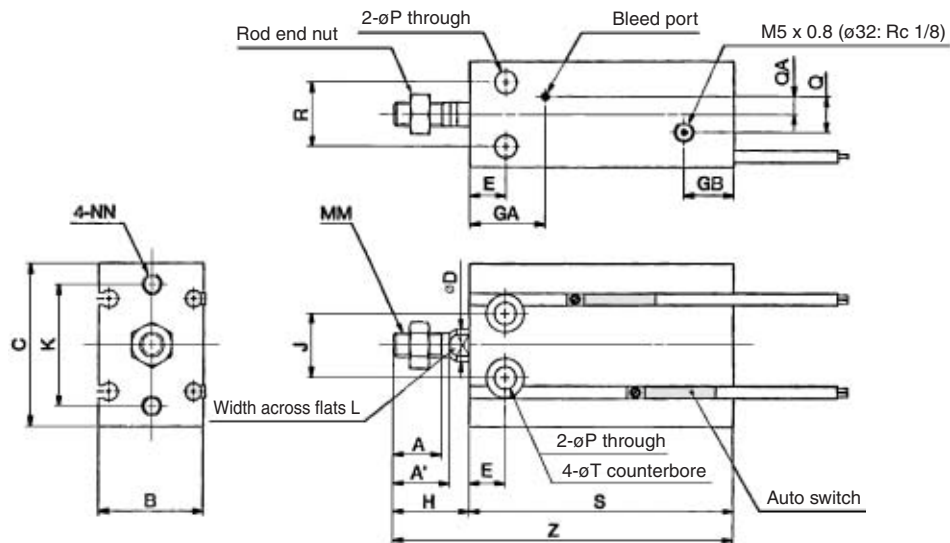

Rod End Nut/Accessory

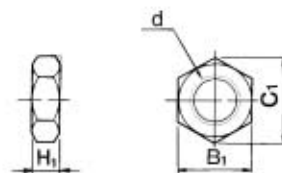

Material: Carbon steel

Part no.	Applicable bore size (mm)	d	H ₁	B ₁	C ₁
NTP-006	6	M3 x 0.5	1.8	5.5	6.4
NTP-010	10	M4 x 0.7	2.4	7	8.1
NTJ-015A	16	M5 x 0.8	4	8	9.2
NT-015A	20	M6 x 1.0	5	10	11.5
NT-02	25	M8 x 1.25	5	13	15.0
NT-03	32	M10 x 1.25	6	17	19.6

Bore size (mm)	A	A'	B	C	D	E	GA	GB	H	J	K	L	MM	NN	P	Q	QA	R	T
6	7	—	13	22	3	7	15	10	13	10	17	—	M3 x 0.5	M3 x 0.5 depth 5	3.2	—	—	7	6 depth 4.8
10	10	—	15	24	4	7	16.5	10	16	11	18	—	M4 x 0.7	M3 x 0.5 depth 5	3.2	—	—	9	6 depth 5
16	11	12.5	20	32	6	7	16.5	11.5	16	14	25	5	M5 x 0.8	M4 x 0.7 depth 6	4.5	4	2	12	7.6 depth 6.5
20	12	14	26	40	8	9	19	12.5	19	16	30	6	M6 x 1.0	M5 x 0.8 depth 8	5.5	9	4.5	16	9.3 depth 8
25	15.5	18	32	50	10	10	21.5	13	23	20	38	8	M8 x 1.25	M5 x 0.8 depth 8	5.5	9	4.5	20	9.3 depth 9
32	19.5	22	40	62	12	11	23	12.5	27	24	48	10	M10 x 1.25	M6 x 1.0 depth 9	6.6	13.5	4.5	24	11 depth 11.5

Bore size (mm)	Without auto switch						With auto switch								
	S			Z			S			Z					
	5 st	10 st	15 st	5 st	10 st	15 st	5 st	10 st	15 st	5 st	10 st	15 st	5 st	10 st	15 st
6	38	43	48	51	56	61	38	43	48	51	56	61	38	43	48
10	41	46	56	57	62	72	41	46	56	57	62	72	41	46	56
16	35	40	50	51	56	66	45	50	60	61	66	76	45	50	60
20	41	46	56	60	65	75	51	56	66	70	75	85	51	56	66
25	45	50	60	68	73	83	55	60	70	78	83	93	55	60	70
32	47	52	62	74	79	89	57	62	72	84	89	99	57	62	72

Dimensions: Single Acting, Spring Extend

ø6, ø10

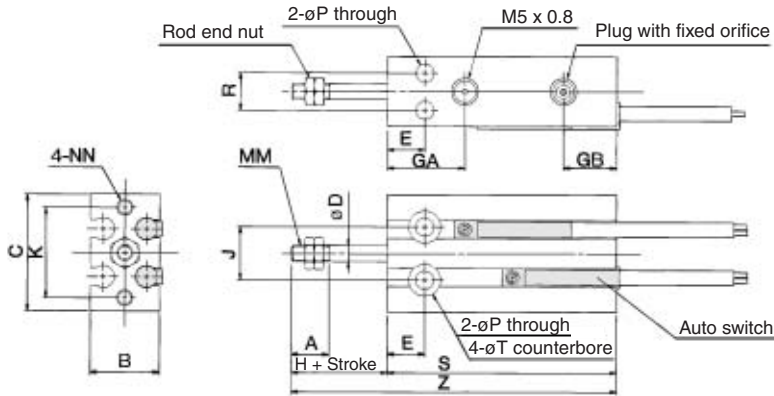

ø16 to ø32

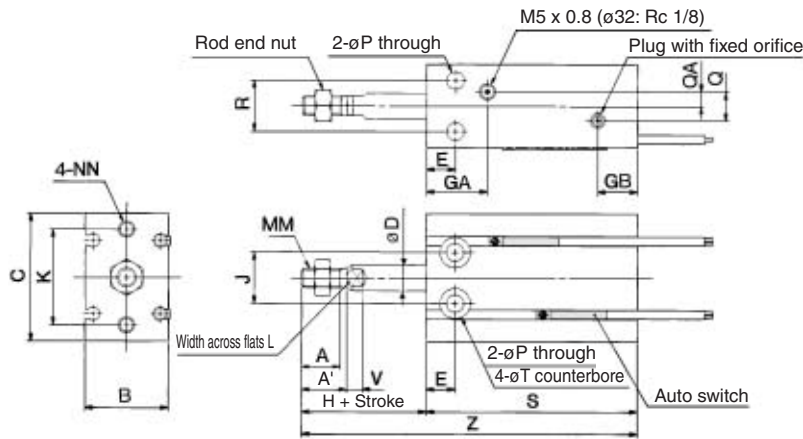

Rod End Nut/Accessory

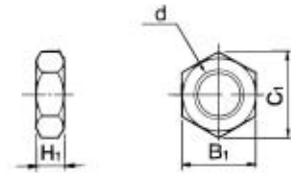

Material: Carbon steel

Part no.	Applicable bore size (mm)	d	H ₁	B ₁	C ₁
NTP-006	6	M3 x 0.5	1.8	5.5	6.4
NTP-010	10	M4 x 0.7	2.4	7	8.1
NTJ-015A	16	M5 x 0.8	4	8	9.2
NT-015A	20	M6 x 1.0	5	10	11.5
NT-02	25	M8 x 1.25	5	13	15.0
NT-03	32	M10 x 1.25	6	17	19.6

(mm)

Bore size (mm)	A	A'	B	C	D	E	GA	GB	H	J	K	L	MM	NN	P	Q	QA	R	T	V
6	7	—	13	22	3	7	15	10	13	10	17	—	M3 x 0.5	M3 x 0.5 depth 5	3.2	—	—	7	6 depth 4.8	—
10	10	—	15	24	4	7	16.5	10	16	11	18	—	M4 x 0.7	M3 x 0.5 depth 5	3.2	—	—	9	6 depth 5	—
16	11	12.5	20	32	6	7	16.5	11.5	16	14	25	5	M5 x 0.8	M4 x 0.7 depth 6	4.5	4	2	12	7.6 depth 6.5	3.5
20	12	14	26	40	8	9	19	12.5	19	16	30	6	M6 x 1.0	M5 x 0.8 depth 8	5.5	9	4.5	16	9.3 depth 8	5
25	15.5	18	32	50	10	10	21.5	13	23	20	38	8	M8 x 1.25	M5 x 0.8 depth 8	5.5	9	4.5	20	9.3 depth 9	5
32	19.5	22	40	62	12	11	23	12.5	27	24	48	10	M10 x 1.25	M6 x 1.0 depth 9	6.6	13.5	4.5	24	11 depth 11.5	5

Bore size (mm)	Without auto switch						With auto switch					
	S			Z			S			Z		
	5 st	10 st	15 st	5 st	10 st	15 st	5 st	10 st	15 st	5 st	10 st	15 st
6	38	43	48	56	66	76	38	43	48	56	66	76
10	41	46	56	62	72	87	41	46	56	62	72	87
16	45	50	60	66	76	91	45	50	60	66	76	91
20	41	46	56	65	75	90	51	56	66	75	85	100
25	45	50	60	73	83	98	55	60	70	83	93	108
32	47	52	62	79	89	104	57	62	72	89	99	114

Series CU

Proper Auto Switch Mounting Position and Its Mounting Height: Single Acting, Spring Return

D-A9□
D-M9□
D-F9□W

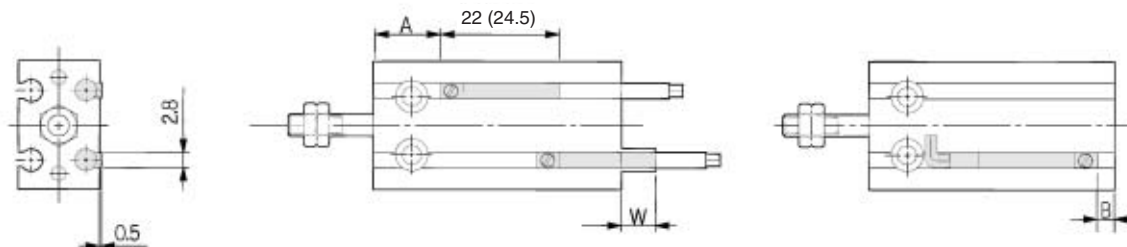

() : Denotes the values of D-A93.

D-A9□V
D-M9□V
D-F9□WV

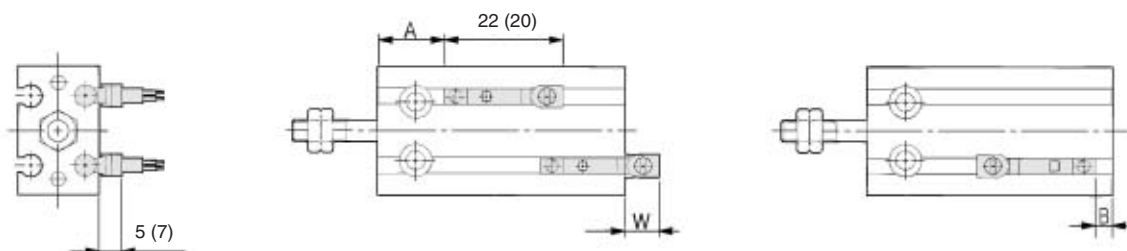

() : Denotes the values of D-M9□V, D-F9□WV.

Single Acting, Spring Return

Bore size (mm)	Stroke	D-A9□, D-A9□V			D-M9□, D-F9□W			D-M9□V, D-F9□WV		
		A	B	W	A	B	W	A	B	W
6	All stroke	13.5	0	2.5(5)	17.5	4	6.5	17.5	4	4.5
10	5, 10	12.5	3.5	-1.5(1)	16.5	7.5	2.5	16.5	7.5	0.5
	15	17.5			21.5			21.5		
16	5, 10	16	4	-2(0.5)	20	8	2	20	8	-0.5
	15	21			25			25		
20	5, 10	20	6	-4(-1.5)	24	10	0	24	10	-2
	15	25			29			29		
25	5, 10	22.5	7	-5.5(-3)	26.5	11	-1.5	26.5	11	-3.5
	15	27.5			31.5			31.5		
32	5, 10	23.5	8.5	-6.5(-4)	27.5	12.5	-2.5	27.5	12.5	-4.5
	15	28.5			32.5			32.5		



Note 1) Figures in the table above are used as a reference when mounting the auto switches for stroke end detection. In the case of actually setting the auto switches, adjust them after confirming their operation.

Note 2) Negative figures in the table W indicate an auto switch is mounted inward from the edge of the cylinder body.

Note 3) In the case of the 5 stroke or the 10 stroke, there are times in which the switch will not turn OFF or 2 switches will turn ON simultaneously due to their movement range. Therefore, set the position approximately 1 to 4 mm outward from the values given in the table above. Then, perform an operation inspection to make sure that the switches operate normally (if 1 switch is used, make sure that it turns ON and OFF properly; if 2 switches are used, make sure that both switches turn ON).

Note 4) () in column W is the dimensions of D-A93.

Proper Auto Switch Mounting Position and Its Mounting Height: Single Acting, Spring Extend

D-A9□
D-M9□
D-F9□W

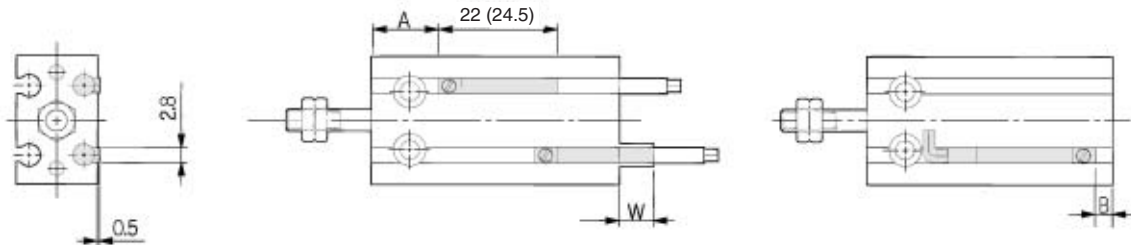

() : Denotes the values of D-A93.

D-A9□V
D-M9□V
D-F9□WV

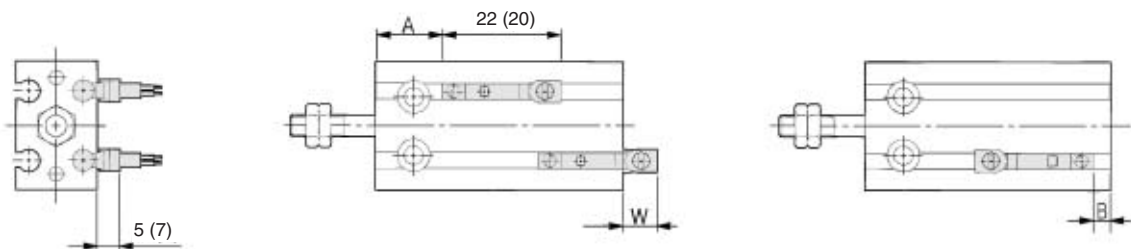

() : Denotes the values of D-M9□V, D-F9□WV.

Single Acting, Spring Extend

Bore size (mm)	Stroke	D-A9□, D-A9□V			D-M9□, D-F9□W			D-M9□V, D-F9□WV		
		A	B	W	A	B	W	A	B	W
6	All stroke	10.5	1.5	0.5(3)	14.5	5.5	4.5	14.5	5.5	2.5
10	5, 10	12.5	3.5	-1.5(1)	16.5	7.5	2.5	16.5	7.5	0.5
	15		8.5	-6.5(-4)		12.5	-2.5		12.5	-4.5
16	5, 10	16	4	-2(0.5)	20	8	2	20	8	0
	15		9	-7(-4.5)		13	-3		13	-5
20	5, 10	20	6	-4(-1.5)	24	10	0	24	10	-2
	15		11	-9(-6.5)		15	-5		15	-7
25	5, 10	22.5	7	-5.5(-3)	26.5	11	-1.5	26.5	11	-3.5
	15		12	-10.5(-8)		16	-6.5		16	-8.5
32	5, 10	23.5	8.5	-6.5(-4)	27.5	12.5	-2.5	27.5	12.5	-4.5
	15		13.5	-11.5(-9)		17.5	-7.5		17.5	-9.5



Note 1) Figures in the table above are used as a reference when mounting the auto switches for stroke end detection. In the case of actually setting the auto switches, adjust them after confirming their operation.

Note 2) Negative figures in the table W indicate an auto switch is mounted inward from the edge of the cylinder body.

Note 3) In the case of the 5 stroke or the 10 stroke, there are times in which the switch will not turn OFF or 2 switches will turn ON simultaneously due to their movement range. Therefore, set the position approximately 1 to 4 mm outward from the values given in the table above. Then, perform an operation inspection to make sure that the switches operate normally (if 1 switch is used, make sure that it turns ON and OFF properly; if 2 switches are used, make sure that both switches turn ON).

Note 4) () in column W is the dimensions of D-A93.

Free Mount Cylinder: Non-rotating Rod Type Double Acting, Single Rod

Series *CUK*

ø6, ø10, ø16, ø20, ø25, ø32



How to Order

Without auto switch **CUK 6** **30** **D**

With auto switch **CDUK 6** **30** **D** **M9B**

• **Built-in magnet**

• **Non-rotating rod type**

• **Bore size**

6	6 mm
10	10 mm
16	16 mm
20	20 mm
25	25 mm
32	32 mm

• **Port thread type**

Symbol	Type	Bore size
Nil	M5 x 0.8	ø6, ø10, ø16, ø20, ø25
	Rc1/8	ø32
TN	NPT1/8	ø32
TF	G1/8	ø32

• **Number of auto switches**

Nil	2 pcs.
S	1 pc.

• **Auto switch**

Nil	Without auto switch
-----	---------------------

* Refer to the table below for applicable auto switches.
* Auto switches are shipped together but not assembled.

• **Action**

D	Double acting
---	---------------

• **Standard stroke (mm)**

ø6, ø10, ø16	5, 10, 15, 20, 25, 30
ø20, ø25, ø32	5, 10, 15, 20, 25, 30, 40, 50

Applicable Auto Switches/Refer to page 68 to 72 for further information on auto switches.

Type	Special function	Electrical entry	Indicator/light	Wiring (Output)	Load voltage		Auto switch model		Lead wire length (m)*			Pre-wired connector	Applicable load		
					DC	AC	Perpendicular	In-line	0.5 (Nil)	3 (L)	5 (Z)				
Reed switch	—	Grommet	Yes	3-wire (NPN equivalent)	—	5 V	—	A96V	A96	●	●	—	—	IC circuit	—
				2-wire	24 V	12 V	100 V	A93V	A93	●	●	—	—	—	Relay, PLC
Solid state switch	Diagnostic indication (2-color indication)	Grommet	Yes	3-wire (NPN)	24 V	5 V, 12 V	—	M9NV	M9N	●	●	○	○	IC circuit	Relay, PLC
				3-wire (PNP)				M9PV	M9P	●	●	○	○	—	
				2-wire				M9BV	M9B	●	●	○	○	—	
				3-wire (NPN)				F9NVV	F9NV	●	●	○	○	IC circuit	
				3-wire (PNP)				F9PVV	F9PV	●	●	○	○	IC circuit	
				2-wire				F9BVV	F9BV	●	●	○	○	—	

* Lead wire length symbols: 0.5 m.....Nil (Example) M9N
3 m.....L (Example) M9NL
5 m.....Z (Example) M9NZ

* Solid state switches marked with "○" are produced upon receipt of order.

* Normally closed (NC=b contact), solid states switches (Model D-F9G, F9H) are also available. For detail, refer to page 7-9-23 in Best Pneumatics 2004 Vol. 7 catalog.

* For detail about auto switches with pre-wired connector, refer to page 7-9-36 in the Best Pneumatics 2004 Vol. 7 catalog.

Free Mount Cylinder: Non-rotating Rod Type **Series CUK**



JIS Symbol

Double acting,
Single rod

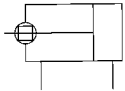

Made to Order Specifications (For details, refer to page 43, 44.)

Symbol	Specifications
-XB6	Heat resistant (150°C)
-XB7	Cold resistant (-40°C)
-XB9	Low speed (10 to 50 mm/s)
-XB13	Low speed (5 to 50 mm/s)
-XC19	Intermediate stroke (with a spacer built-in)
-XC22	Seals made of fluorine rubber
-XC34	Threaded for mounting a work on non-rotating plate (No protrusion from the edge of rod)

⚠ Precautions

Be sure to read before handling.
Refer to back page 1 through to 6 for
Safety Instructions, Actuator Precautions
and Auto Switch Precautions.

Operating Precautions

⚠ Caution

1. Do not place your fingers in the clearance between the non-rotating plate and the cylinder tube.

Your fingers could get caught between the non-rotating plate and the cylinder tube when the piston rod retracts. Therefore, never place your finger in this area.

Because the cylinder outputs a great force, it could lead to injury if precautions are not taken to prevent your fingers from getting caught.

2. When using the non-rotating style, make sure that rotational torque is not applied to the piston rod. If rotational torque must be applied due to unavoidable circumstances, make sure to use it at the allowable rotational torque or less, which is shown in the table on the right.

Specifications

Bore size (mm)	6	10	16	20	25	32
Fluid	Air					
Proof pressure	1.05 MPa					
Maximum operating pressure	0.7 MPa					
Minimum operating pressure	0.15 MPa	0.10 MPa	0.08 MPa			
Ambient and fluid temperature	Without auto switch: -10 to 70°C (No freezing) With auto switch: -10 to 60°C (No freezing)					
Lubrication	Non-lube					
Piston speed	50 to 500 mm/s					
Cushion	Rubber bumper					
Rod end thread	Male thread					
Thread tolerance	JIS Class 2					
Stroke length tolerance	+ ¹ / ₀ mm					
Rod non-rotating accuracy <small>Note)</small>	±0.8°			±0.5°		

Note) No load: Rod at retracted

Standard Stroke

Bore size (mm)	Standard stroke (mm)	For long stroke, refer to page 39.
6, 10, 16	5, 10, 15, 20, 25, 30	
20, 25, 32	5, 10, 15, 20, 25, 30, 40, 50	

Minimum Stroke for Auto Switch Mounting

(mm)

No. of auto switches mounted	Applicable auto switch		
	D-A9□, D-A9□V	D-M9□, D-M9□V	D-F9□W, D-F9□WV
1 pc.	5	5	5
2 pcs.	10	5	10

Weight/(): Denotes the values with D-A93.

(g)

Bore size (mm)	Stroke (mm)							
	5	10	15	20	25	30	40	50
C(D)UK6-□D	28 (33)	31 (41)	34 (44)	37 (47)	40 (50)	43 (53)	—	—
C(D)UK10-□D	43 (48)	47 (57)	51 (61)	55 (65)	59 (69)	63 (73)	—	—
C(D)UK16-□D	60 (85)	66 (96)	72 (102)	78 (108)	84 (114)	90 (120)	—	—
C(D)UK20-□D	113 (147)	124 (164)	136 (176)	148 (188)	160 (200)	172 (211)	195 (235)	219 (260)
C(D)UK25-□D	212 (266)	229 (288)	246 (305)	263 (322)	280 (339)	297 (356)	335 (390)	370 (424)
C(D)UK32-□D	331 (404)	357 (435)	383 (461)	409 (487)	435 (513)	461 (539)	513 (591)	565 (643)

* For the auto switch weight, refer to page 68 to 72.

Allowable Rotational Torque

Bore size (mm)	6	10	16	20	25	32
Allowable rotational torque (N-m)	0.0015	0.02	0.04	0.10	0.15	0.20

Tightening Torque

When mounting Series CUK, refer to page 3.

Auto Switch Mounting Position

For the auto switch mounting position of Series CDUK, refer to page 6, since specifications are the same as standard type, double acting, single rod type.

Theoretical Output

Specifications are the same as CU series double acting, single rod. Refer to page 3.

Series CUK

Copper-free

20-CUK **Bore size** — **Stroke** D

• Copper-free

The type which prevents copper based ions from generating by changing the copper based materials into electroless nickel plated treatment or non-copper materials in order to eliminate the effects by copper based ions or fluororesins over the color cathode ray tube.

Minimum Operating Pressure (MPa)

Bore size (mm)	6	10, 16	20, 25, 32
Minimum operating pressure	0.15	0.10	0.08

Construction

ø6

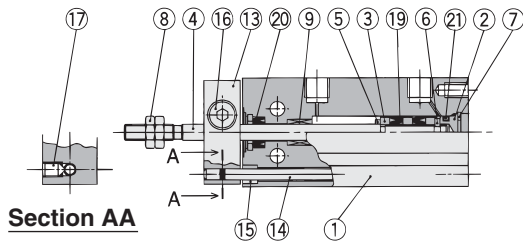

ø10

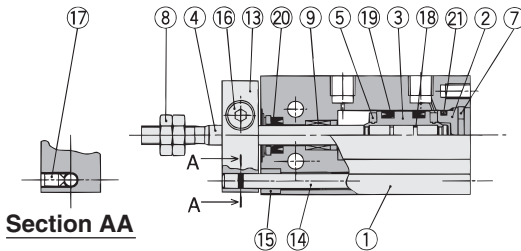

ø16 to ø32

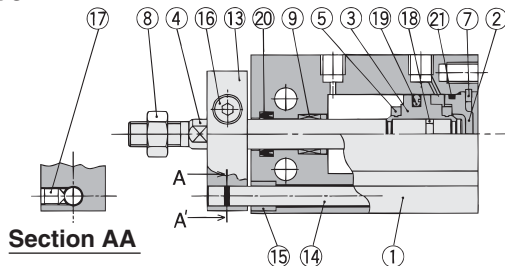

Specifications

Action	Double acting, Single rod
Bore size (mm)	6, 10, 16, 20, 25, 32
Maximum operating pressure	1.05 MPa
Cushion	Rubber bumper
Stroke	Same as standard type (Refer to page 2.)
Auto switch	Mountable

With auto switch

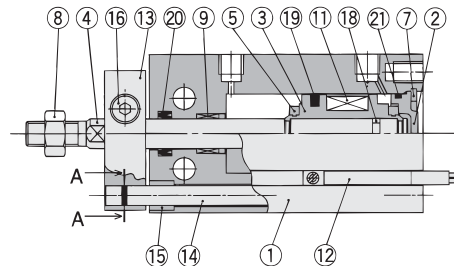
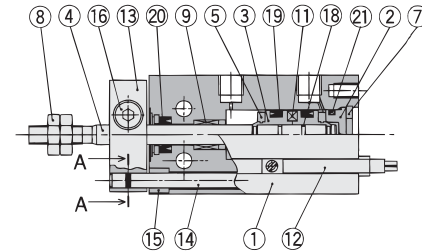
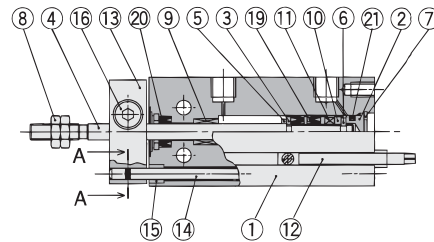

Component Parts

No.	Description	Material	Note
1	Cylinder tube	Aluminum alloy	Hard anodized
2	Head cover	Brass	ø6 to ø10, Electroless nickel plated
		Aluminum alloy	ø16 to ø32, Clear chromated
3	Piston	Brass	ø6 to ø10,
		Aluminum alloy	ø16 to ø32, Chromated
4	Piston rod	Stainless steel	
5	Bumper A	Urethane	
6	Bumper B	Urethane	
7	Snap ring	Carbon tool steel	Phosphate coated
8	Rod end nut	Carbon steel	Nickel plated
9	Bushing	Oil-impregnated sintered alloy	
10	Magnet holder	Brass	ø6

Replacement Parts: Seal Kit

Bore size (mm)	Kit no.	Contents
10	CU10D-PS	Set of nos. above (19), (20), (21).
16	CU16D-PS	
20	CU20D-PS	
25	CU25D-PS	
32	CU32D-PS	

Component Parts

No.	Description	Material	Note
11	Magnet	Magnetic material	
12	Auto switch		
13	Non-rotating plate	Aluminum alloy	Nickel plated
14	Guide rod	Stainless steel	
15	Bushing	Oil-impregnated sintered alloy	
16	Hexagon socket head cap screw	Carbon steel	Black zinc chromated
17	Hexagon socket head set screw	Carbon steel	Black zinc chromated
18	Piston gasket	NBR	
19*	Piston seal		
20*	Rod seal		
21*	Gasket		



* Seal kit includes (19), (20), (21). Order the seal kit, based on each bore size.

Dimensions: Non-rotating Rod Type; Double Acting, Single Rod

ø6, ø10

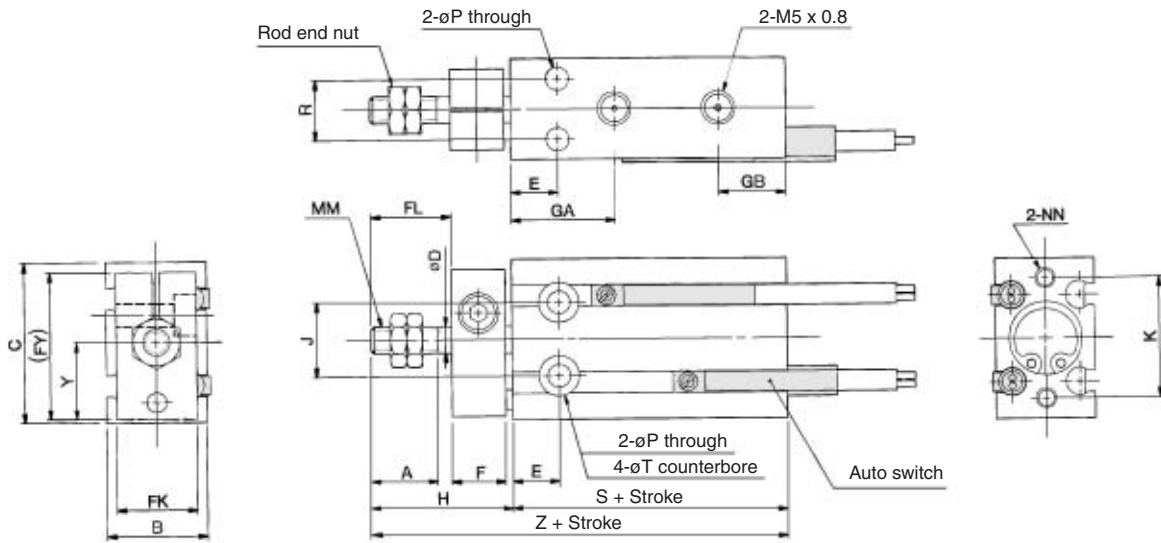

ø16 to ø32

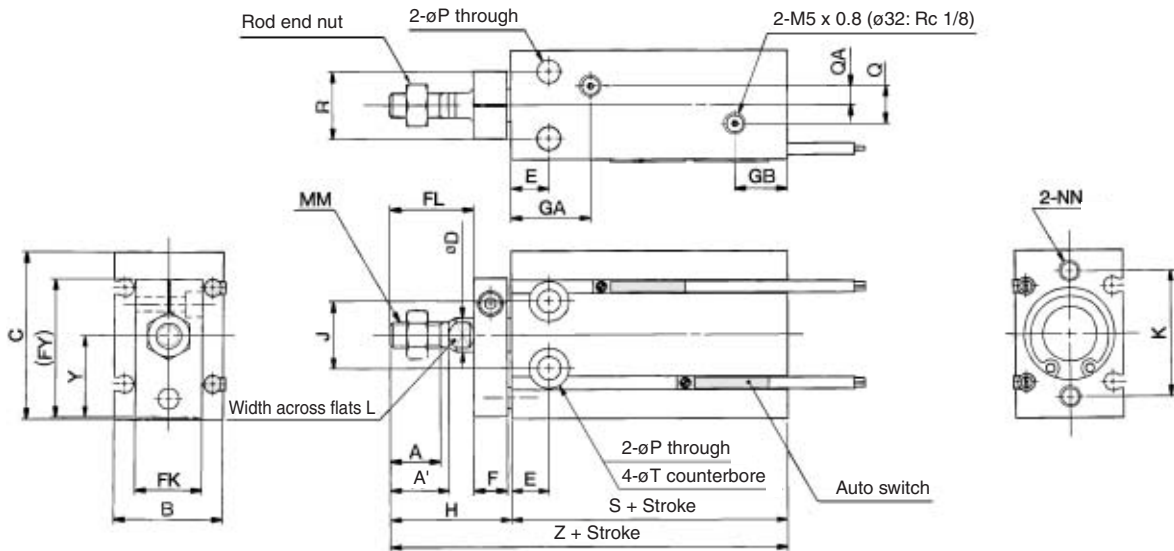

Rod End Nut/Accessory

Material: Carbon steel

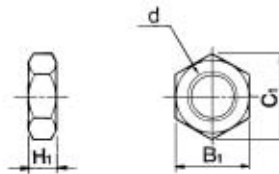

Part no.	Applicable bore size (mm)	d	H ₁	B ₁	C ₁
NTP-006	6	M3 x 0.5	1.8	5.5	6.4
NTP-010	10	M4 x 0.7	2.4	7	8.1
NTJ-015A	16	M5 x 0.8	4	8	9.2
NT-015A	20	M6 x 1.0	5	10	11.5
NT-02	25	M8 x 1.25	5	13	15.0
NT-03	32	M10 x 1.25	6	17	19.6

(mm)

Bore size (mm)	A	A'	B	C	D	E	F	FL	FK	FY	GA	GB	H	J	K	L	MM
6	7	—	13	22	3	7	8	9	11	20.5	15	10	18	10	17	—	M3 x 0.5
10	10	—	15	24	4	7	8	12	12	22	16.5	10	21	11	18	—	M4 x 0.7
16	11	12.5	20	32	6	7	8	17	13	28	16.5 ^{Note)}	11.5	26	14	25	5	M5 x 0.8
20	12	14	26	40	8	9	8	20	16	33	19	12.5	29	16	30	6	M6 x 1.0
25	15.5	18	32	50	10	10	10	22	20	43.5	21.5	13	33	20	38	8	M8 x 1.25
32	19.5	22	40	62	12	11	12	29	24	51.5	23	12.5	42	24	48	10	M10 x 1.25

Bore size (mm)	NN	P	Q	QA	R	T	Y	Without auto switch		With auto switch	
								S	Z	S	Z
6	M3 x 0.5 depth 5	3.2	—	—	7	6 depth 4.8	10.5	33	51	33	51
10	M3 x 0.5 depth 5	3.2	—	—	9	6 depth 5	11.5	36	57	36	57
16	M4 x 0.7 depth 6	4.5	4	2	12	7.6 depth 6.5	15.5	30	56	40	66
20	M5 x 0.8 depth 8	5.5	9	4.5	16	9.3 depth 8	19.5	36	65	46	75
25	M5 x 0.8 depth 8	5.5	9	4.5	20	9.3 depth 9	24.5	40	73	50	83
32	M6 x 1.0 depth 9	6.6	13.5	4.5	24	11 depth 11.5	30.5	42	84	52	94

Note) 5 stroke (CUK16-5D): GA = 14.5

Free Mount Cylinder: Non-rotating Rod Type Double Acting, Double Rod Series **CUKW**



ø6, ø10, ø16, ø20, ø25, ø32

How to Order

Without auto switch CUKW 6 [] 30 D

With auto switch CDUKW 6 [] 30 D - M9B []

Number of auto switches

Nil	2 pcs.
S	1 pc.

Auto switch

Nil	Without auto switch
-----	---------------------

* Refer to the table below for applicable auto switches.
* Auto switches are shipped together but not assembled.

Built-in magnet

Non-rotating rod type

Double rod

Bore size

6	6 mm
10	10 mm
16	16 mm
20	20 mm
25	25 mm
32	32 mm

Action

D	Double acting
---	---------------

Standard stroke (mm)

ø6, ø10, ø16	5, 10, 15, 20, 25, 30, 40, 50, 60
ø20, ø25, ø32	5, 10, 15, 20, 25, 30, 40, 50, 60, 70, 80, 90, 100

Port thread type

Symbol	Type	Bore size
Nil	M5 x 0.8	ø6, ø10, ø16, ø20, ø25
	Rc1/8	ø32
TN	NPT1/8	ø32
TF	G1/8	ø32

Applicable Auto Switches/Refer to page 68 to 72 for further information on auto switches.

Type	Special function	Electrical entry	Indicator/light	Wiring (Output)	Load voltage		Auto switch model		Lead wire length (m)*			Pre-wired connector	Applicable load		
					DC	AC	Perpendicular	In-line	0.5 (Nil)	3 (L)	5 (Z)				
Reed switch	—	Grommet	Yes	3-wire (NPN equivalent)	—	5 V	—	A96V	A96	●	●	—	—	IC circuit	—
				2-wire	24 V	12 V	100 V	A93V	A93	●	●	—	—	—	IC circuit
Solid state switch	Diagnostic indication (2-color indication)	Grommet	Yes	3-wire (NPN)	24 V	5 V, 12 V	—	M9NV	M9N	●	●	○	○	IC circuit	Relay, PLC
				3-wire (PNP)				M9PV	M9P	●	●	○	○	—	
				2-wire				M9BV	M9B	●	●	○	○	—	
				3-wire (NPN)				F9N WV	F9N W	●	●	○	○	IC circuit	
				3-wire (PNP)				F9P WV	F9P W	●	●	○	○	IC circuit	
				2-wire				F9B WV	F9B W	●	●	○	○	—	

* Lead wire length symbols: 0.5 m.....Nil (Example) M9N
3 m.....L (Example) M9NL
5 m.....Z (Example) M9NZ

* Solid state switches marked with "○" are produced upon receipt of order.

* Normally closed (NC=b contact), solid states switches (Model D-F9G, F9H) are also available. For detail, refer to page 7-9-23 in Best Pneumatics 2004 Vol. 7 catalog.
* For detail about auto switches with pre-wired connector, refer to page 7-9-36 in the Best Pneumatics 2004 Vol. 7 catalog.

Free Mount Cylinder: Non-rotating Rod Type Double Acting, Double Rod **Series CUKW**



Specifications

Bore size (mm)	6	10	16	20	25	32
Fluid	Air					
Proof pressure	1.05 MPa					
Maximum operating pressure	0.7 MPa					
Minimum operating pressure	0.18 MPa	0.13 MPa	0.11 MPa			
Ambient and fluid temperature	Without auto switch: -10 to 70°C (No freezing) With auto switch: -10 to 60°C (No freezing)					
Lubrication	Non-lube					
Piston speed	50 to 500 mm/s					
Cushion	Rubber bumper					
Rod end thread	Male thread					
Thread tolerance	JIS Class 2					
Stroke length tolerance	+ ⁰ / ₀ mm					
Rod non-rotating accuracy <small>Note)</small>	±0.8°			±0.5°		

Note) No load: Rod in the non-rotating plate side at retracted

Standard Stroke

Bore size (mm)	Standard stroke (mm)
6, 10, 16	5, 10, 15, 20, 25, 30, 40, 50, 60
20, 25, 32	5, 10, 15, 20, 25, 30, 40, 50, 60, 70, 80, 90, 100

Minimum Stroke for Auto Switch Mounting

(mm)

No. of auto switches mounted	Applicable auto switch		
	D-A9□, D-A9□V	D-M9□, D-M9□V	D-F9□W, D-F9□WV
1 pc.	5	5	5
2 pcs.	10	5	10

JIS Symbol

Non-rotating rod

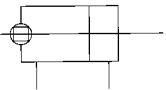

Weight/(): Denotes the values with D-A93.

(g)

Model	Stroke (mm)												
	5	10	15	20	25	30	40	50	60	70	80	90	100
C(D)UKW6-□D	33 (38)	36 (46)	40 (50)	43 (53)	46 (56)	50 (60)	57 (67)	64 (74)	71 (81)	—	—	—	—
C(D)UKW10-□D	51 (56)	56 (66)	60 (70)	65 (75)	69 (79)	74 (84)	83 (93)	92 (102)	101 (111)	—	—	—	—
C(D)UKW16-□D	84 (109)	91 (121)	98 (128)	105 (135)	112 (142)	119 (149)	133 (163)	147 (177)	161 (191)	—	—	—	—
C(D)UKW20-□D	150 (185)	163 (203)	177 (217)	191 (231)	205 (245)	219 (259)	247 (286)	275 (315)	303 (343)	331 (371)	359 (399)	387 (427)	415 (455)
C(D)UKW25-□D	276 (330)	296 (355)	316 (375)	336 (395)	357 (416)	377 (436)	421 (476)	462 (516)	500 (559)	541 (600)	582 (641)	623 (682)	664 (723)
C(D)UKW32-□D	434 (507)	465 (543)	495 (573)	526 (604)	556 (634)	587 (665)	669 (747)	709 (787)	770 (848)	831 (909)	892 (970)	953 (1031)	1014 (1092)

* For the auto switch weight, refer to page 68 to 72.

Theoretical Output

Specifications are the same as double acting, double rod (Series CUW). Refer to page 9.

Tightening Torque

When mounting Series CUKW, refer to page 3.

Allowable Rotational Torque

Ensure that rotational torque is not applied to the piston rod of Series CUKW. If rotational torque are applied unavoidably, refer to page 22.

Auto Switch Mounting Position

For the auto switch mounting position of Series CUKW, refer to page 12, since specifications are the same as double acting, double rod type.

Series CUKW

Construction

ø6

With auto switch

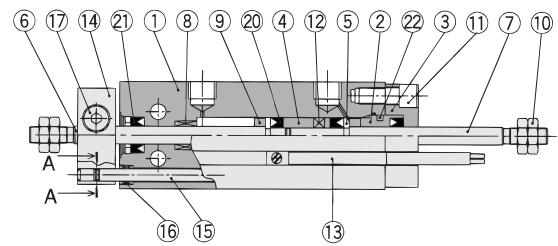
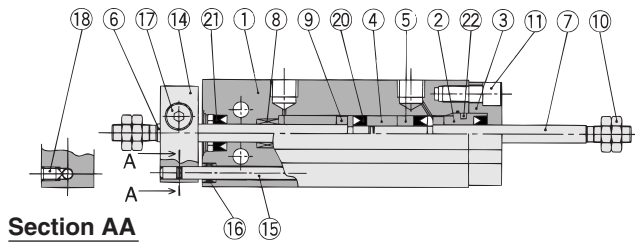

ø10

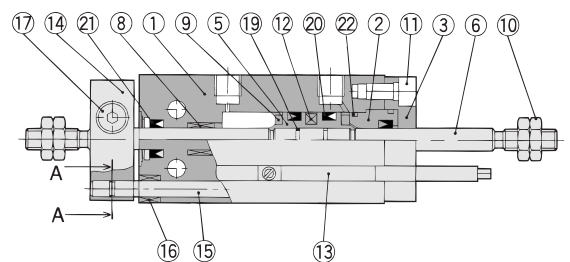
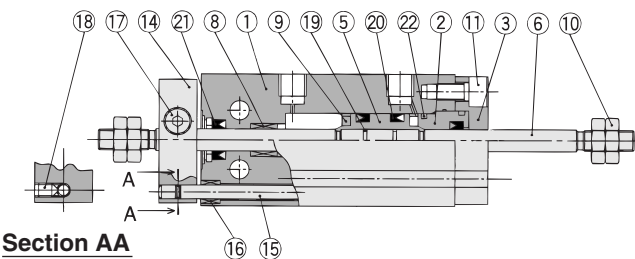

ø16 to ø32

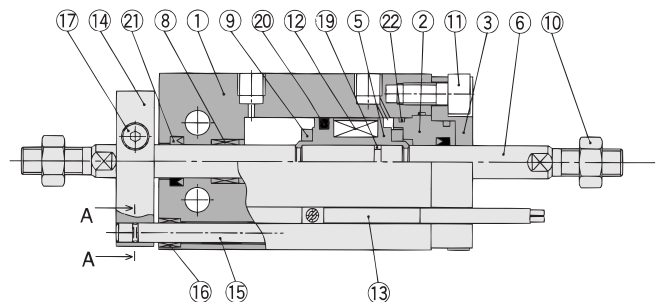
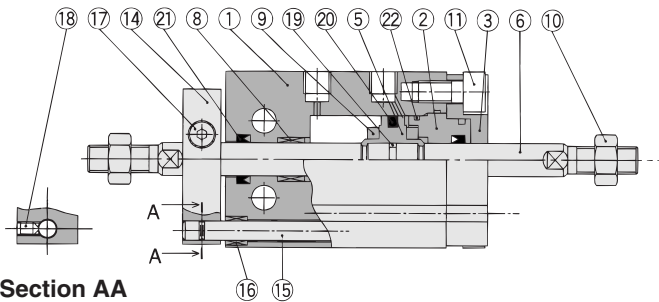

Component Parts

No.	Description	Material	Note
1	Cylinder tube	Aluminum alloy	Hard anodized
2	Rod cover	Aluminum bearing alloy	Chromated
3	Rod cover retainer	Aluminum alloy	Hard anodized
4	Piston	Brass	ø6
5	Piston	Aluminum alloy	ø16 to ø32, Chromated
6	Piston rod	Stainless steel	
7	Piston rod	Stainless steel	ø6
8	Bushing	Oil-impregnated sintered alloy	
9	Bumper	Urethane	
10	Rod end nut	Carbon steel	Nickel plated
11	Hexagon socket head cap screw	Carbon steel	Nickel plated

Component Parts

No.	Description	Material	Note
12	Magnet	Magnetic material	
13	Auto switch	—	
14	Non-rotating plate	Aluminum alloy	Nickel plated
15	Guide rod	Stainless steel	
16	Bushing	Oil-impregnated sintered alloy	
17	Hexagon socket head cap screw	Carbon steel	Black zinc chromated
18	Hexagon socket head set screw	Carbon steel	Black zinc chromated
19	Piston gasket	NBR	
20	Piston seal		
21	Rod seal		
22	Gasket		

Replacement Parts: Seal Kit

Kit no.	Bore size (mm) / Part no.				
	10	16	20	25	32
	CUW10D-PS	CUW16D-PS	CUW20D-PS	CUW25D-PS	CUW32D-PS

* Seal kit includes 20, 21, 22. Order the seal kit, based on each bore size.

Dimensions: Non-rotating Rod Type; Double Acting, Double Rod

ø6, ø10

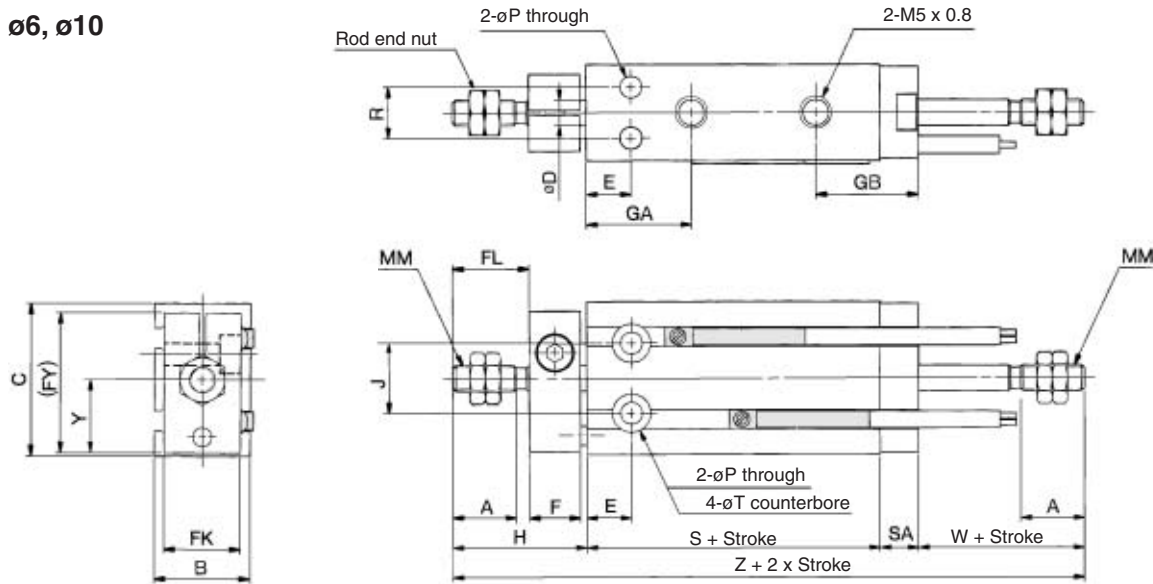

ø16 to ø32

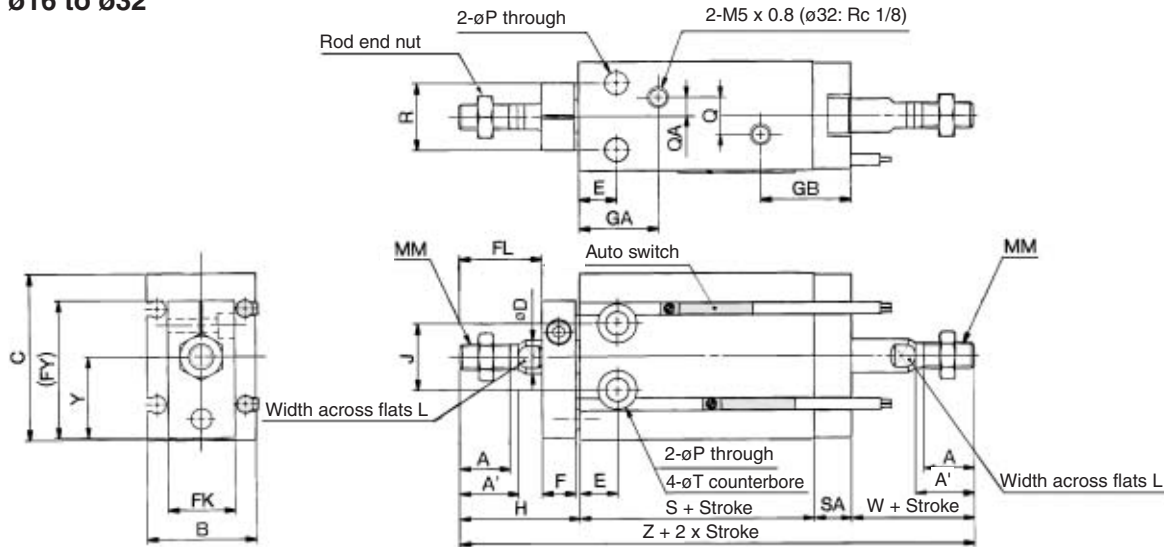

Rod End Nut/Accessory

Material: Carbon steel

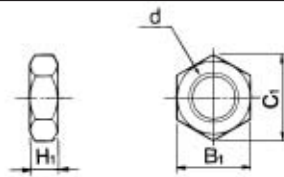

Part no.	Applicable bore size (mm)	d	H ₁	B ₁	C ₁
NTP-006	6	M3 x 0.5	1.8	5.5	6.4
NTP-010	10	M4 x 0.7	2.4	7	8.1
NTJ-015A	16	M5 x 0.8	4	8	9.2
NT-015A	20	M6 x 1.0	5	10	11.5
NT-02	25	M8 x 1.25	5	13	15.0
NT-03	32	M10 x 1.25	6	17	19.6

Bore size (mm)	A	A'	B	C	D	E	F	FL	FK	FY	GA	GB	H	J	L	MM
6	7	—	13	22	3	7	8	9	11	20.5	15	16	18	10	—	M3 x 0.5
10	10	—	15	24	4	7	8	12	12	22	16.5	16	21	11	—	M4 x 0.7
16	11	12.5	20	32	6	7	8	17	13	28	16.5 ^{Note)}	19	26	14	5	M5 x 0.8
20	12	14	26	40	8	9	8	20	16	33	19	21.5	29	16	6	M6 x 1.0
25	15.5	18	32	50	10	10	10	22	20	43.5	21.5	22	33	20	8	M8 x 1.25
32	19.5	22	40	62	12	11	12	29	24	51.5	23	22.5	42	24	10	M10 x 1.25

Bore size (mm)	P	Q	QA	R	SA	T	W	Y	Without auto switch		With auto switch	
									S	Z	S	Z
6	3.2	—	—	7	6	6 depth 4.8	13	10.5	38	75	38	75
10	3.2	—	—	9	6	6 depth 5	16	11.5	36	79	36	79
16	4.5	4	2	12	7.5	7.6 depth 6.5	16	15.5	30	79.5	40	89.5
20	5.5	9	4.5	16	9	9.3 depth 8	19	19.5	36	93	46	103
25	5.5	9	4.5	20	9	9.3 depth 9	23	24.5	40	105	50	115
32	6.6	13.5	4.5	24	10	11 depth 11.5	27	30.5	42	121	52	131

Note) 5 stroke (CUKW16-5D): GA = 14.5

Free Mount Cylinder: Non-rotating Rod Type

Single Acting, Single Rod, Spring Return/Extend

Series *CUK*

ø6, ø10, ø16, ø20, ø25, ø32



How to Order

Without auto switch

CUK 10 [] 15 S

With auto switch

CDUK 10 [] 15 S M9B []

Bore size

6	6 mm
10	10 mm
16	16 mm
20	20 mm
25	25 mm
32	32 mm

Port thread type

Symbol	Type	Bore size
Nil	M5 x 0.8	ø6, ø10, ø16, ø20, ø25
	Rc1/8	ø32
TN	NPT1/8	ø32
TF	G1/8	ø32

Standard stroke (mm)

ø6, ø10, ø16	5, 10, 15
ø20, ø25, ø32	

Number of auto switches

Nil	2 pcs.
S	1 pc.

Auto switch

Nil	Without auto switch
-----	---------------------

* Refer to the table below for applicable auto switches.
* Auto switches are shipped together but not assembled.

Action

S	Single acting, Spring return
T	Single acting, Spring extend

Built-in magnet

Non-rotating rod type

Applicable Auto Switches/Refer to page 68 to 72 for further information on auto switches.

Type	Special function	Electrical entry	Indicator light	Wiring (Output)	Load voltage			Auto switch model		Lead wire length (m)*			Pre-wired connector	Applicable load	
					DC	AC	Perpendicular	In-line	0.5 (Nil)	3 (L)	5 (Z)				
												24 V			
Reed switch	—	Grommet	Yes	3-wire (NPN equivalent)	—	5 V	—	A96V	A96	●	●	—	—	IC circuit	—
				2-wire	24 V	12 V	100 V	A93V	A93	●	●	—	—	—	Relay, PLC
Solid state switch	—	Grommet	Yes	3-wire (NPN)	24 V	5 V, 12 V	—	M9NV	M9N	●	●	○	○	IC circuit	Relay, PLC
				3-wire (PNP)				M9PV	M9P	●	●	○	○		
				2-wire				M9BV	M9B	●	●	○	○		
				3-wire (NPN)				F9N WV	F9N W	●	●	○	○		
				3-wire (PNP)				F9P WV	F9P W	●	●	○	○		
				2-wire				F9B WV	F9B W	●	●	○	○		

* Lead wire length symbols: 0.5 m.....Nil (Example) M9N
 3 m.....L (Example) M9NL
 5 m.....Z (Example) M9NZ

* Solid state switches marked with "○" are produced upon receipt of order.

* Normally closed (NC=b contact), solid states switches (Model D-F9G, F9H) are also available. For detail, refer to page 7-9-23 in Best Pneumatics 2004 Vol. 7 catalog.
 * For detail about auto switches with pre-wired connector, refer to page 7-9-36 in the Best Pneumatics 2004 Vol. 7 catalog.

Free Mount Cylinder: Non-rotating Rod Type Single Acting, Single Rod, Spring Return/Extend **Series CUK**



Specifications

Bore size (mm)	6	10	16	20	25	32
Fluid	Air					
Proof pressure	1.05 MPa					
Maximum operating pressure	0.7 MPa					
Minimum operating pressure	0.23 MPa	0.18 MPa	0.16 MPa			
Ambient and fluid temperature	Without auto switch: -10 to 70°C (No freezing) With auto switch: -10 to 60°C (No freezing)					
Lubrication	Non-lube					
Piston speed	50 to 500 mm/s					
Cushion ⁽¹⁾	Rubber bumper on both ends					
Rod end thread	Male thread					
Thread tolerance	JIS Class 2					
Stroke length tolerance	+1.0 0 mm					
Rod non-rotating accuracy ⁽²⁾	±0.8°			±0.5°		

Note 1) ø6: With auto switch, single rubber bumper

Note 2) No load: Rod at retracted

Standard Stroke

Bore size (mm)	Standard stroke (mm)
6, 10, 16, 20, 25, 32	5, 10, 15

JIS Symbol

Single acting,
Spring return

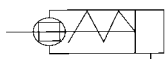

Single acting,
Spring extend



Minimum Stroke for Auto Switch Mounting

No. of auto switches mounted	Applicable auto switch		
	D-A9□, D-A9□V	D-M9□, D-M9□V	D-F9□W, D-F9□WV
1 pc.	5	5	5
2 pcs.	10	5	10

Weight/(): Denotes the values with D-A93

Model	Stroke (mm)		
	5	10	15
C(D)UK6-□ $\begin{smallmatrix} S \\ T \end{smallmatrix}$	28 (33)	31 (41)	34 (44)
C(D)UK10-□ $\begin{smallmatrix} S \\ T \end{smallmatrix}$	43 (48)	47 (57)	55 (65)
C(D)UK16-□ $\begin{smallmatrix} S \\ T \end{smallmatrix}$	60 (85)	66 (90)	81 (111)
C(D)UK20-□ $\begin{smallmatrix} S \\ T \end{smallmatrix}$	113 (147)	124 (164)	153 (193)
C(D)UK25-□ $\begin{smallmatrix} S \\ T \end{smallmatrix}$	212 (266)	229 (288)	271 (330)
C(D)UK32-□ $\begin{smallmatrix} S \\ T \end{smallmatrix}$	331 (404)	357 (435)	422 (500)

* For the auto switch weight, refer to page 68 to 72.



Made to Order Specifications (For details, refer to page 43, 44.)

Symbol	Specifications
-XC22	Seals made of fluorine rubber
-XC34	Threaded for mounting a work on non-rotating plate (No protrusion from the edge of rod)

Tightening Torque

When mounting a CUK single acting series, refer to page 3.

Theoretical Output

Specifications are the same as single acting, spring return/spring extend type (Series CU). Refer to page 14.

Spring Reaction Force

For the reactive force of spring return, refer to page 7-12-3 in Best Pneumatics 2004 Vol. 7 catalog.

Auto Switch Mounting Position

For the auto switch mounting position of CDUK series single acting, spring return/spring extend, refer to page 19 to 20, since specification are the same as standard type, single acting, spring return/spring extend type.

Allowable Rotational Torque

Make sure that rotational torque is not applied to the piston rod of the CUK series single acting type cylinder. If the rotation torque were applied unavoidably, refer to page 22.

Series CUK

Construction

Single acting, Spring return

ø6

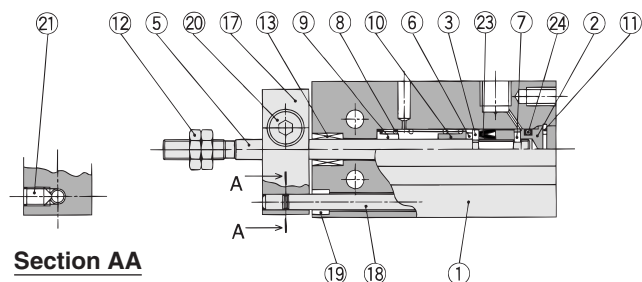

Section AA

ø10

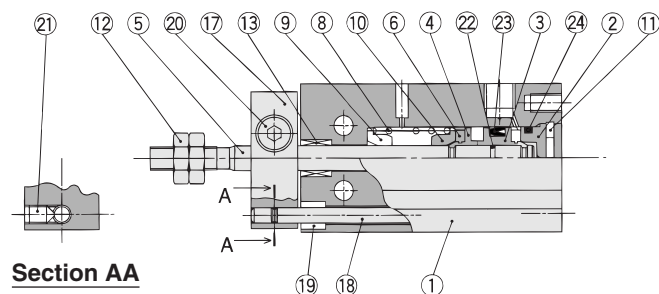

Section AA

ø16 to ø32

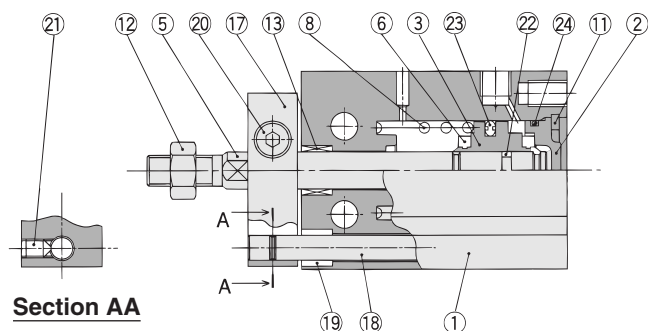

Section AA

With auto switch

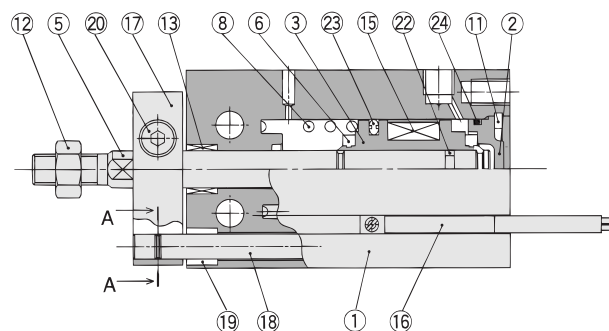
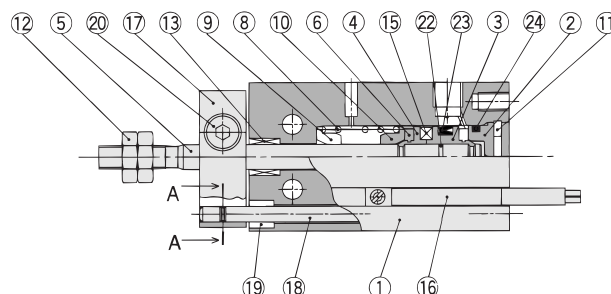
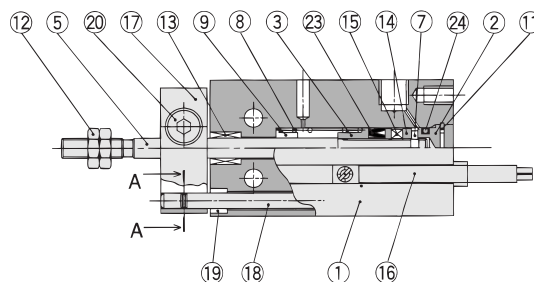

Component Parts

No.	Description	Material	Note
1	Cylinder tube	Aluminum alloy	Hard anodized
2	Head cover	Brass	ø6 to ø10, Electroless nickel plated
		Aluminum alloy	ø16 to ø32, Clear chromated
3	Piston	Brass	ø6 to ø10
		Aluminum alloy	ø16 to ø32, Chromated
4	Piston	Brass	ø10
5	Piston rod	Stainless steel	
6	Bumper A	Urethane	
7	Bumper B	Urethane	
8	Return spring	Piano wire	Zinc chromated
9	Spring seat	Brass	
10	Spring seat	Brass	

Component Parts

No.	Description	Material	Note
11	Snap ring	Carbon tool steel	Phosphate coated
12	Rod end nut	Carbon steel	Nickel plated
13	Bushing	Oil-impregnated sintered alloy	
14	Magnet holder	Brass	ø6
15	Magnet	Magnetic material	
16	Auto switch	—	
17	Non-rotating plate	Aluminum alloy	Nickel plated
18	Guide rod	Stainless steel	
19	Bushing	Oil-impregnated sintered alloy	Black zinc chromated
20	Hexagon socket head cap screw	Carbon steel	Black zinc chromated
21	Hexagon socket head set screw	Carbon steel	
22	Piston gasket	NBR	
23*	Piston seal		
24*	Gasket		

Replacement Parts: Seal Kit

Kit no.	Bore size (mm) / Part no.				
	10	16	20	25	32
	CU10S-PS	CU16S-PS	CU20S-PS	CU25S-PS	CU32S-PS

* Seal kit includes 23, 24. Order the seal kit, based on each bore size.

Construction

Single acting, Spring extend

ø6

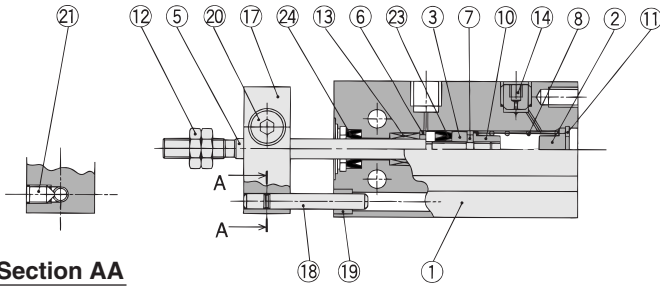

Section AA

With auto switch

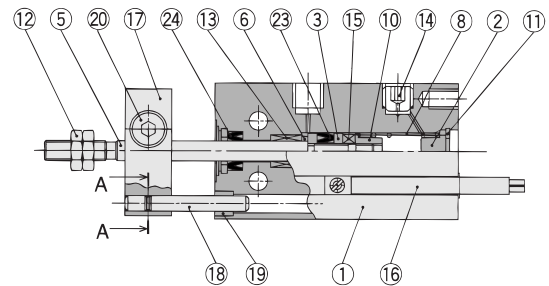

ø10

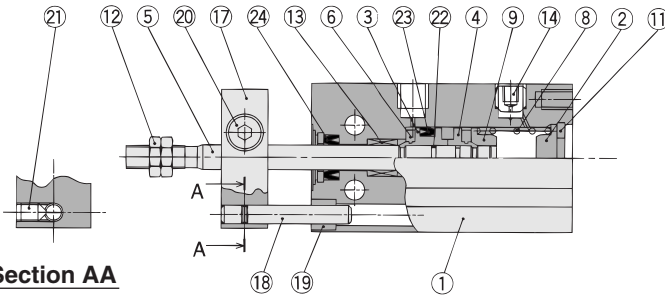

Section AA

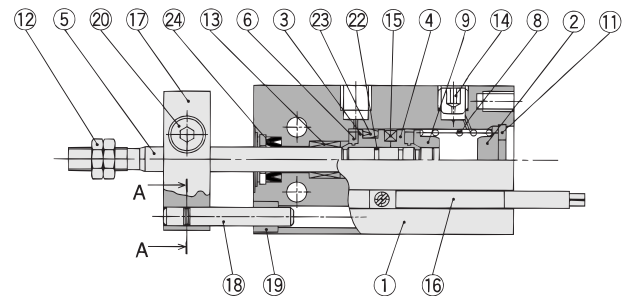

ø16 to ø32

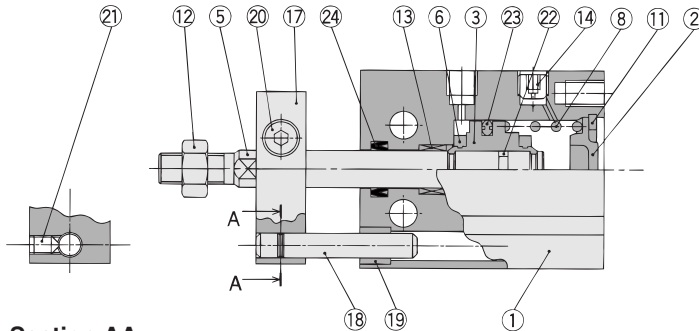

Section AA

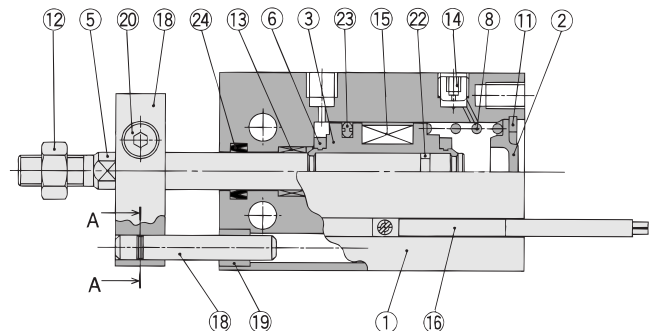

Component Parts

No.	Description	Material	Note
1	Cylinder tube	Aluminum alloy	Hard anodized
2	Head cover	Brass	ø6 to ø10, Electroless nickel plated
		Aluminum alloy	ø16 to ø32, Clear chromated
3	Piston	Brass	ø6 to ø10
		Aluminum alloy	ø16 to ø32, Chromated
4	Piston	Brass	ø10
5	Piston rod	Stainless steel	
6	Bumper A	Urethane	
7	Bumper B	Urethane	
8	Return spring	Piano wire	Zinc chromated
9	Spring seat	Brass	
10	stopper	Brass	ø6
11	Snap ring	Carbon tool steel	Phosphate coated

Component Parts

No.	Description	Material	Note
12	Rod end nut	Carbon steel	Nickel plated
13	Bushing	Oil-impregnated sintered alloy	
14	Plug with fixed orifice	Alloy steel	Black zinc chromated
15	Magnet	Magnetic material	
16	Auto switch	—	
17	Non-rotating plate	Aluminum alloy	Nickel plated
18	Guide rod	Stainless steel	
19	Bushing	Oil-impregnated sintered alloy	Black zinc chromated
20	Hexagon socket head cap screw	Carbon steel	Black zinc chromated
21	Hexagon socket head set screw	Carbon steel	
22	Piston gasket	NBR	
23*	Piston seal		
24*	Rod seal		

Replacement Parts: Seal Kit

Kit no.	Bore size (mm) / Part no.				
	10	16	20	25	32
	CU10T-PS	CU16T-PS	CU20T-PS	CU25T-PS	CU32T-PS

* Seal kit includes 23, 24. Order the seal kit, based on each bore size.

Series CUK

Dimensions: Non-rotating Rod Type; Single Acting, Spring Return

ø6, ø10

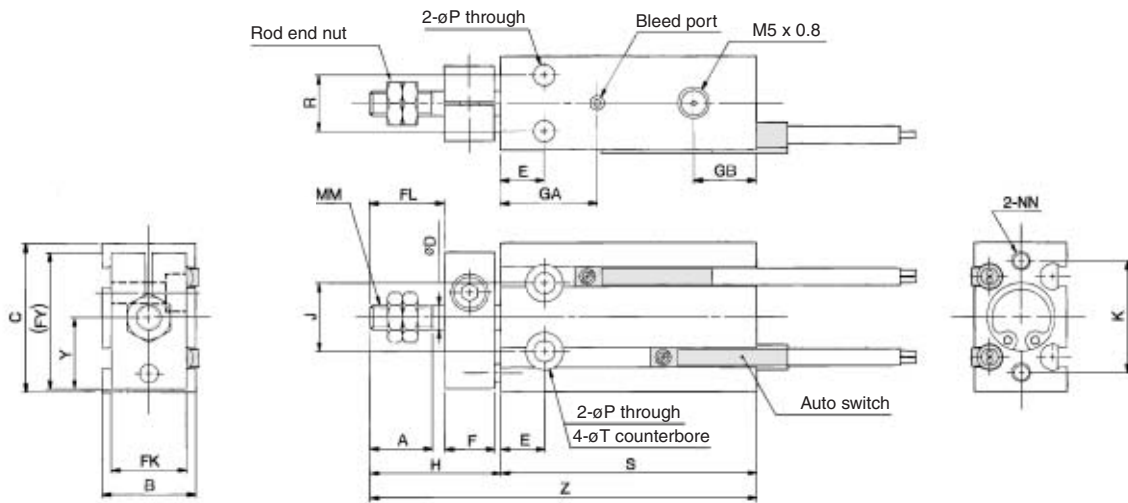

ø16 to ø32

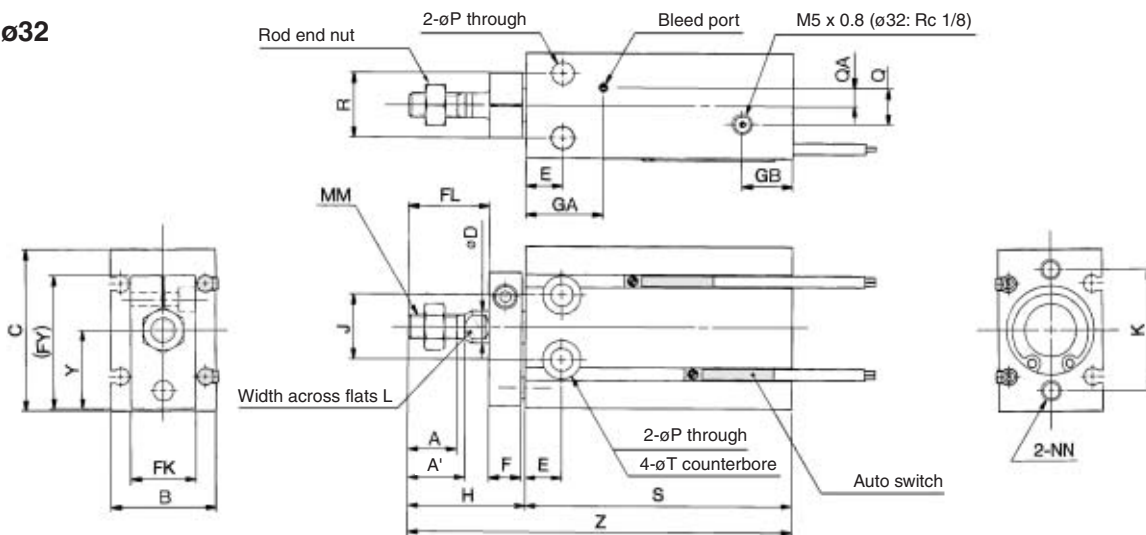

Rod End Nut/Accessory

Material: Carbon steel

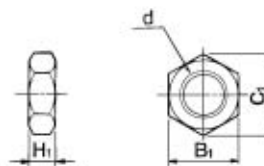

Part no.	Applicable bore size (mm)	d	H ₁	B ₁	C ₁
NTP-006	6	M3 x 0.5	1.8	5.5	6.4
NTP-010	10	M4 x 0.7	2.4	7	8.1
NTJ-015A	16	M5 x 0.8	4	8	9.2
NT-015A	20	M6 x 1.0	5	10	11.5
NT-02	25	M8 x 1.25	5	13	15.0
NT-03	32	M10 x 1.25	6	17	19.6

Bore size (mm)	A	A'	B	C	D	E	F	FL	FK	FY	GA	GB	H	J	K	L	MM	NN
6	7	—	13	22	3	7	8	9	11	20.5	15	10	18	10	17	—	M3 x 0.5	M3 x 0.5 depth 5
10	10	—	15	24	4	7	8	12	12	22	16.5	10	21	11	18	—	M4 x 0.7	M3 x 0.5 depth 5
16	11	12.5	20	32	6	7	8	17	13	28	16.5	11.5	26	14	25	5	M5 x 0.8	M4 x 0.7 depth 6
20	12	14	26	40	8	9	8	20	16	33	19	12.5	29	16	30	6	M6 x 1.0	M5 x 0.8 depth 8
25	15.5	18	32	50	10	10	10	22	20	43.5	21.5	13	33	20	38	8	M8 x 1.25	M5 x 0.8 depth 8
32	19.5	22	40	62	12	11	12	29	24	51.5	23	12.5	42	24	48	10	M10 x 1.25	M6 x 1.0 depth 9

Bore size (mm)	P	Q	QA	R	T	Y	Without auto switch						With auto switch					
							S			Z			S			Z		
							5 st	10 st	15 st	5 st	10 st	15 st	5 st	10 st	15 st	5 st	10 st	15 st
6	3.2	—	—	7	6 depth 4.8	10.5	38	43	48	56	61	66	38	43	48	56	61	66
10	3.2	—	—	9	6 depth 5	11.5	41	46	56	62	67	77	41	46	56	62	67	77
16	4.5	4	2	12	7.6 depth 6.5	15.5	35	40	50	61	66	76	45	50	60	71	76	86
20	5.5	9	4.5	16	9.3 depth 8	19.5	41	46	56	70	75	85	51	56	66	80	85	95
25	5.5	9	4.5	20	9.3 depth 9	24.5	45	50	60	78	83	93	55	60	70	88	93	103
32	6.6	13.5	4.5	24	11 depth 11.5	30.5	47	52	62	89	94	104	57	62	72	99	104	114

Dimensions: Non-rotating Rod Type; Single Acting, Spring Extend

ø6, ø10

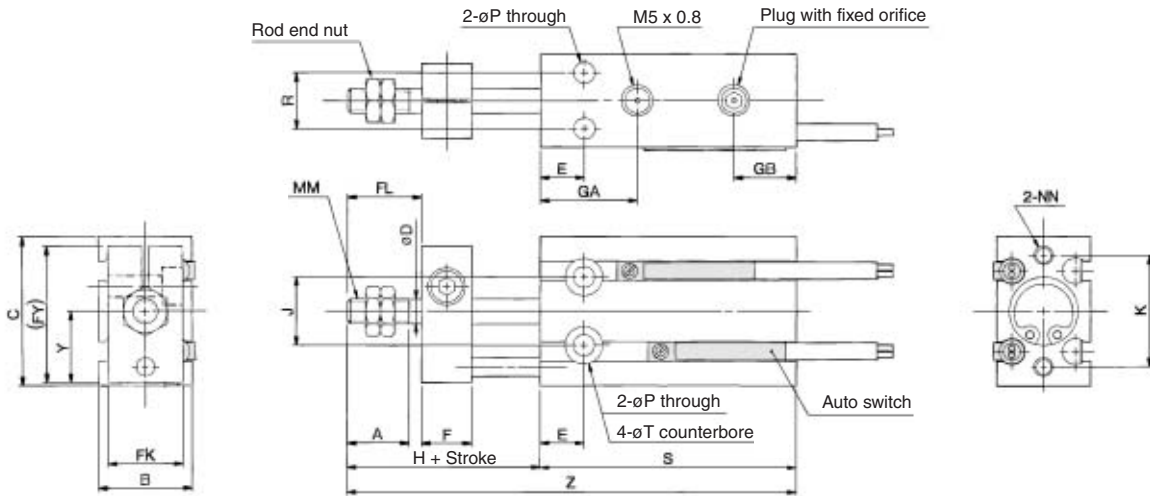

ø16 to ø32

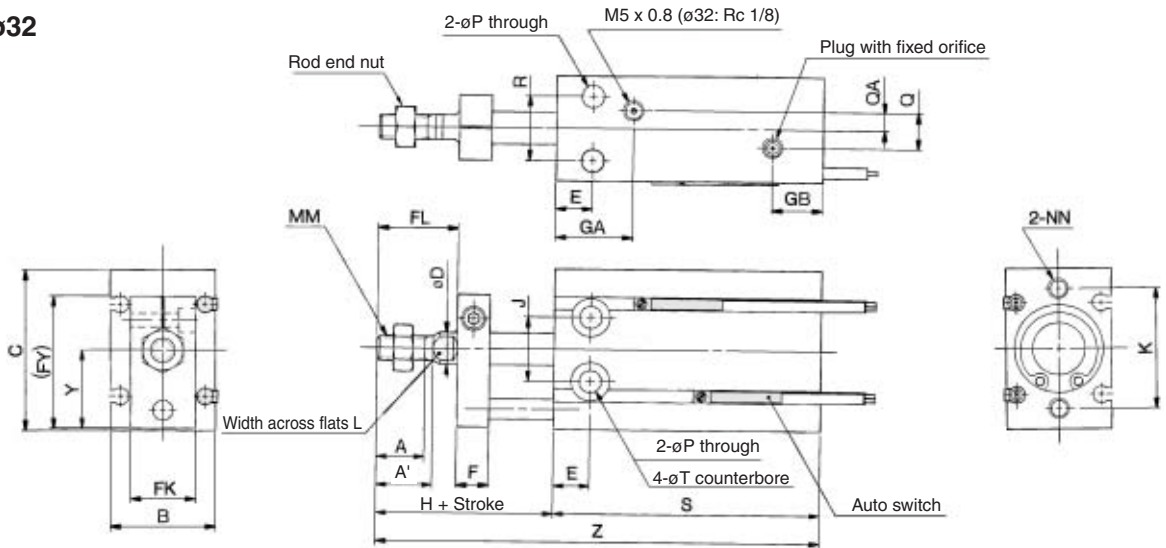

Rod End Nut/Accessory

Material: Carbon steel

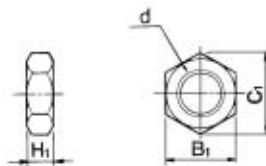

Part no.	Applicable bore size (mm)	d	H ₁	B ₁	C ₁
NTP-006	6	M3 x 0.5	1.8	5.5	6.4
NTP-010	10	M4 x 0.7	2.4	7	8.1
NTJ-015A	16	M5 x 0.8	4	8	9.2
NT-015A	20	M6 x 1.0	5	10	11.5
NT-02	25	M8 x 1.25	5	13	15.0
NT-03	32	M10 x 1.25	6	17	19.6

Bore size (mm)	A	A'	B	C	D	E	F	FL	FK	FY	GA	GB	H	J	K	L	MM	NN
6	7	—	13	22	3	7	8	9	11	20.5	15	10	18	10	17	—	M3 x 0.5	M3 x 0.5 depth 5
10	10	—	15	24	4	7	8	12	12	22	16.5	10	21	11	18	—	M4 x 0.7	M3 x 0.5 depth 5
16	11	12.5	20	32	6	7	8	17	13	28	16.5	11.5	26	14	25	5	M5 x 0.8	M4 x 0.7 depth 6
20	12	14	26	40	8	9	8	20	16	33	19	12.5	29	16	30	6	M6 x 1.0	M5 x 0.8 depth 8
25	15.5	18	32	50	10	10	10	22	20	43.5	21.5	13	33	20	38	8	M8 x 1.25	M5 x 0.8 depth 8
32	19.5	22	40	62	12	11	12	29	24	51.5	23	12.5	42	24	48	10	M10 x 1.25	M6 x 1.0 depth 9

Bore size (mm)	P	Q	QA	R	T	Y	Without auto switch						With auto switch					
							S			Z			S			Z		
							5 st	10 st	15 st	5 st	10 st	15 st	5 st	10 st	15 st	5 st	10 st	15 st
6	3.2	—	—	7	6 depth 4.8	10.5	38	43	48	61	71	81	38	43	48	61	71	81
10	3.2	—	—	9	6 depth 5	11.5	41	46	56	67	77	92	41	46	56	67	77	92
16	4.5	4	2	12	7.6 depth 6.5	15.5	45	50	60	76	86	101	45	50	60	76	86	101
20	5.5	9	4.5	16	9.3 depth 8	19.5	41	46	56	75	85	100	51	56	66	85	95	110
25	5.5	9	4.5	20	9.3 depth 9	24.5	45	50	60	83	93	108	55	60	70	93	103	118
32	6.6	13.5	4.5	24	11 depth 11.5	30.5	47	52	62	94	104	119	57	62	72	104	114	129

Free Mount Cylinder: Long Stroke Type Double Acting, Single Rod

Series CU

ø6, ø10, ø16, ø20, ø25, ø32



How to Order

Without auto switch CU 6 [] 60 D

With auto switch CDU 6 [] 60 D M9B []

Built-in magnet

Bore size

6	6 mm
10	10 mm
16	16 mm
20	20 mm
25	25 mm
32	32 mm

Port thread type

Symbol	Type	Bore size
Nil	M5 x 0.8	ø6, ø10, ø16, ø20, ø25
	Rc1/8	ø32
TN	NPT1/8	ø32
TF	G1/8	ø32

Long stroke (mm)

ø6, ø10, ø16	40, 50, 60
ø20, ø25, ø32	60, 70, 80, 90, 100

Action

D	Double acting
---	---------------

Auto switch

Nil	Without auto switch
-----	---------------------

* Refer to the table below for applicable auto switches.
* Auto switches are shipped together but not assembled.

Number of auto switches

Nil	2 pcs.
S	1 pc.

Applicable Auto Switches/Refer to page 68 to 72 for further information on auto switches.

Type	Special function	Electrical entry	Indicator/light	Wiring (Output)	Load voltage			Auto switch model		Lead wire length (m)*			Pre-wired connector	Applicable load	
					DC	AC	Perpendicular	In-line	0.5 (Nil)	3 (L)	5 (Z)	Applicable load			
												IC circuit		Relay, PLC	
Reed switch	—	Grommet	Yes	3-wire (NPN equivalent)	—	5 V	—	A96V	A96	●	●	—	—	IC circuit	—
				2-wire	24 V	12 V	100 V	A93V	A93	●	●	—	—	—	Relay, PLC
Solid state switch	Diagnostic indication (2-color indication)	Grommet	Yes	3-wire (NPN)	24 V	5 V, 12 V	100 V or less	M9NV	M9N	●	●	○	○	IC circuit	Relay, PLC
				3-wire (PNP)				M9PV	M9P	●	●	○	○	IC circuit	
				2-wire				M9BV	M9B	●	●	○	○	—	
				3-wire (NPN)				F9NWV	F9NW	●	●	○	○	IC circuit	
				3-wire (PNP)				F9PWV	F9PW	●	●	○	○	IC circuit	
				2-wire				F9BWV	F9BW	●	●	○	○	—	
				2-wire				F9BWV	F9BW	●	●	○	○	—	

* Lead wire length symbols: 0.5 m.....Nil (Example) M9N
3 m.....L (Example) M9NL
5 m.....Z (Example) M9NZ

* Solid state switches marked with "○" are produced upon receipt of order.

* Normally closed (NC=b contact), solid states switches (Model D-F9G, F9H) are also available. For detail, refer to page 7-9-23 in Best Pneumatics 2004 Vol. 7 catalog.

* For detail about auto switches with pre-wired connector, refer to page 7-9-36 in the Best Pneumatics 2004 Vol. 7 catalog.

Free Mount Cylinder: Long Stroke Type Double Acting, Single Rod **Series CU**



Specifications

Bore size (mm)	6	10	16	20	25	32
Fluid	Air					
Proof pressure	1.05 MPa					
Maximum operating pressure	0.7 MPa					
Minimum operating pressure	0.12 MPa	0.06 MPa	0.05 MPa			
Ambient and fluid temperature	Without auto switch: -10 to 70°C (No freezing) With auto switch: -10 to 60°C (No freezing)					
Lubrication	Non-lube					
Piston speed	50 to 500 mm/s					
Cushion	Rubber bumper					
Rod end thread	Male thread					
Thread tolerance	JIS Class 2					
Stroke length tolerance	$^{+1.0}_0$ mm					

Standard Stroke

Bore size (mm)	Standard stroke (mm)
6, 10, 16	40, 50, 60
20, 25, 32	60, 70, 80, 90, 100

JIS Symbol

Double acting,
Spring rod

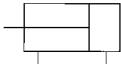

Made to Order Specifications (For details, refer to P.43.)

Symbol	Specifications
-XB6	Heat resistant (150°C)
-XB7	Cold resistant (-40°C)
-XB9	Low speed (10 to 50 mm/s)
-XB13	Low speed (5 to 50 mm/s)
-XC19	Intermediate stroke (with a spacer built-in)
-XC22	Seals made of fluorine rubber

Weight/(): Denotes the values with D-A93.

(g)

Model	Stroke (mm)						
	40	50	60	70	80	90	100
C(D)U6-□D	43 (53)	49 (59)	50 (65)	—	—	—	—
C(D)U10-□D	64 (74)	72 (82)	80 (90)	—	—	—	—
C(D)U16-□D	92 (122)	104 (134)	116 (146)	—	—	—	—
C(D)U20-□D	—	—	216 (253)	238 (275)	260 (297)	282 (319)	304 (341)
C(D)U25-□D	—	—	363 (422)	397 (456)	431 (490)	465 (524)	499 (558)
C(D)U32-□D	—	—	526 (604)	574 (652)	622 (700)	670 (748)	718 (796)

* For the auto switch weight, refer to page 68 to 72.

Auto Switch Mounting Position

For the auto switch mounting position of CDU long stroke series, refer to page 6, since specifications are the same as standard type, double acting, single rod type.

Tightening Torque

Refer to page 3 for mounting a long stroke type.

Theoretical Output

Specifications are the same as CU series double acting, single rod. Refer to page 3.

Series CU

Copper-free

20-CU Bore size — Stroke D

• Copper-free

The type which prevents copper based ions from generating by changing the copper based materials into electroless nickel plated treatment or non-copper materials in order to eliminate the effects by copper based ions or fluororesins over the color cathode ray tube.

Minimum Operating Pressure (MPa)

Bore size (mm)	6	10, 16	20, 25, 32
Minimum operating pressure	0.12	0.12	0.05

Construction

ø6

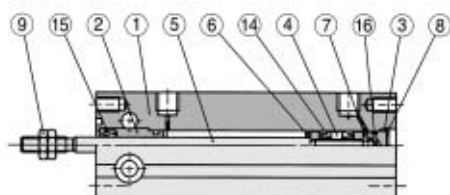

ø10

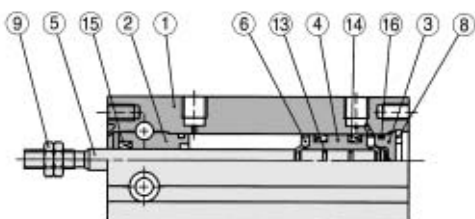

ø16 to ø32

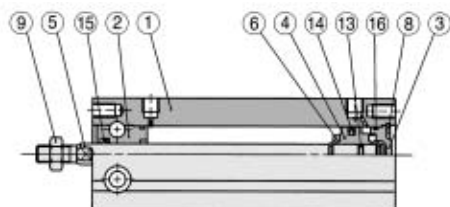

Specifications

Action	Double acting, Single rod
Bore size (mm)	6, 10, 16, 20, 25, 32
Maximum operating pressure	1.05 MPa
Cushion	Rubber bumper
Stroke	Same as standard type (Refer to page 3.)
Auto switch	Mountable

With auto switch

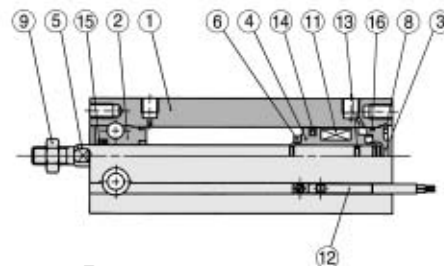
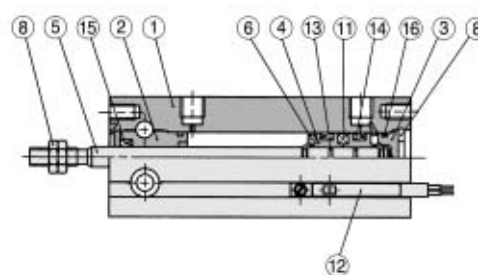
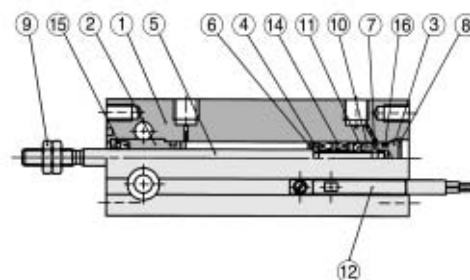

Component Parts

No.	Description	Material	Note
1	Cylinder tube	Aluminum alloy	Hard anodized
2	Rod cover	Aluminum bearing alloy	Hard anodized
3	Head cover	Brass	ø6 to ø10, Electroless nickel plated
		Aluminum alloy	ø16 to ø32, Clear chromated
4	Piston	Brass	ø6 to ø10
		Aluminum alloy	ø16 to ø32, Chromated
5	Piston rod	Stainless steel	
6	Bumper A	Urethane	
7	Bumper B	Urethane	

Component Parts

No.	Description	Material	Note
8	Snap ring	Carbon tool steel	Phosphate coated
9	Rod end nut	Carbon steel	Nickel plated
10	Magnet holder	Brass	ø6
11	Magnet	Magnetic material	
12	Auto switch	—	
13	Piston gasket	NBR	
14	Piston seal		
15	Rod seal		
16	Gasket		

Replacement Parts: Seal Kit

Bore size (mm)	Kit no.	Contents
10	CU10D-PS	Set of nos. above ⑭, ⑮, ⑯.
16	CU16D-PS	
20	CU20D-PS	
25	CU25D-PS	
32	CU32D-PS	

* Seal kit includes ⑭, ⑮, ⑯. Order the seal kit, based on each bore size.

Dimensions: Double Acting, Single Rod

ø6, ø10

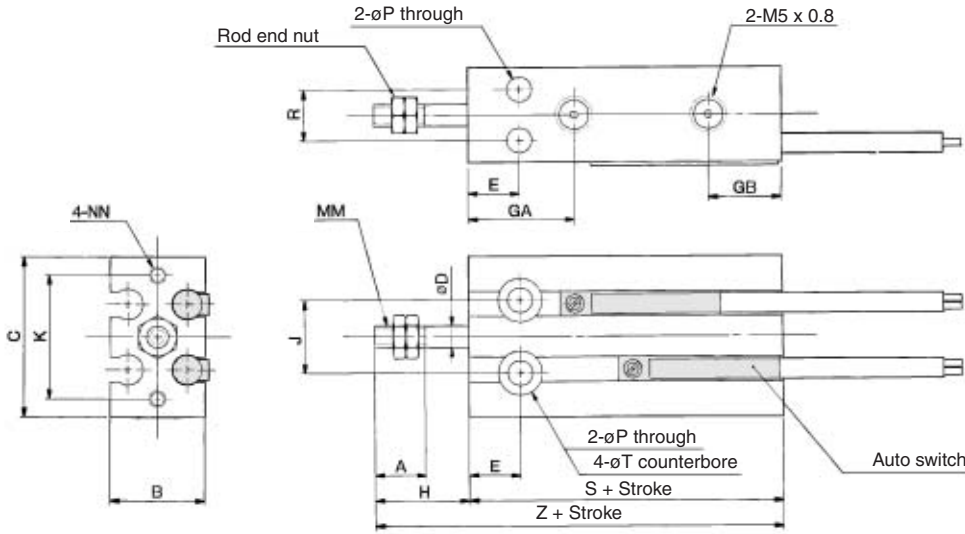

ø16 to ø32

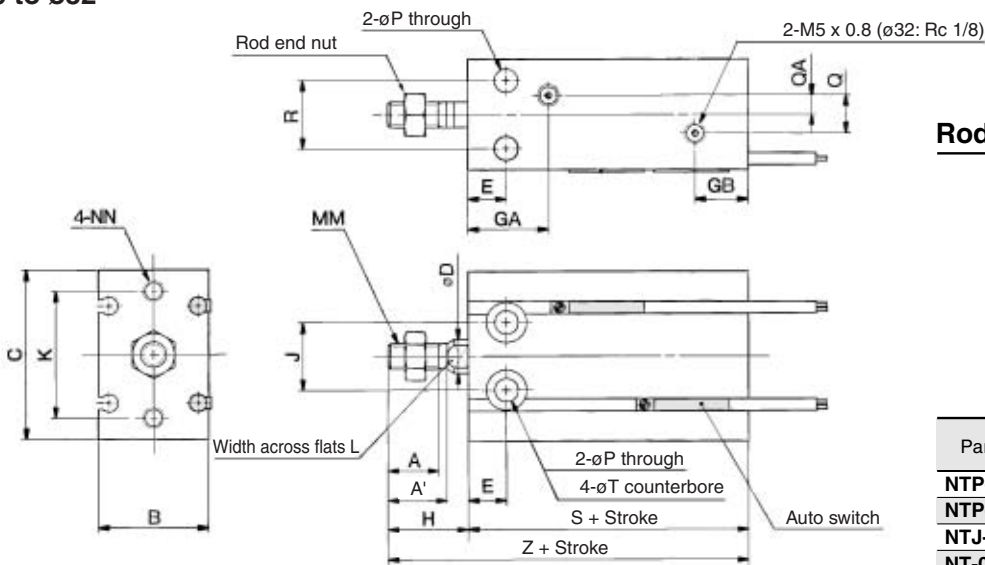

Rod End Nut/Accessory

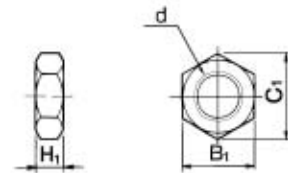

Material: Carbon steel

Part no.	Applicable bore (mm)	d	H ₁	B ₁	C ₁
NTP-006	6	M3 x 0.5	1.8	5.5	6.4
NTP-010	10	M4 x 0.7	2.4	7	8.1
NTJ-015A	16	M5 x 0.8	4	8	9.2
NT-015A	20	M6 x 1.0	5	10	11.5
NT-02	25	M8 x 1.25	5	13	15.0
NT-03	32	M10 x 1.25	6	17	19.6

Bore size (mm)	A	A'	B	C	D	E	GA	GB	H	J	K	L	MM	NN	P	Q	QA
6	7	—	13	22	3	7	15	10	13	10	17	—	M3 x 0.5	M3 x 0.5 depth 5	3.2	—	—
10	10	—	15	24	4	7	16.5	10	16	11	18	—	M4 x 0.7	M3 x 0.5 depth 5	3.2	—	—
16	11	12.5	20	32	6	7	16.5	11.5	16	14	25	5	M5 x 0.8	M4 x 0.7 depth 6	4.5	4	2
20	12	14	26	40	8	9	19	12.5	19	16	30	6	M6 x 1.0	M5 x 0.8 depth 8	5.5	9	4.5
25	15.5	18	32	50	10	10	21.5	13	23	20	38	8	M8 x 1.25	M5 x 0.8 depth 8	5.5	9	4.5
32	19.5	22	40	62	12	11	23	12.5	27	24	48	10	M10 x 1.25	M6 x 1.0 depth 9	6.6	13.5	4.5

Bore size (mm)	R	T	Without auto switch		With auto switch	
			S	Z	S	Z
6	7	6 depth 4.8	33	46	33	46
10	9	6 depth 5	36	52	36	52
16	12	7.6 depth 6.5	30	46	40	56
20	16	9.3 depth 8	36	55	46	65
25	20	9.3 depth 9	40	63	50	73
32	24	11 depth 11.5	42	69	52	79

Free Mount Cylinder: Long Stroke Type Non-rotating Rod, Double Acting, Single Rod Series **CUK** ø6, ø10, ø16, ø20, ø25, ø32



How to Order

Without auto switch CUK 6 [] 60 D

With auto switch CDUK 6 [] 60 D M9B []

Built-in magnet (points to '6' in CUK)

Non-rotating rod type (points to 'CUK' in CUK)

Bore size

6	6 mm
10	10 mm
16	16 mm
20	20 mm
25	25 mm
32	32 mm

Port thread type

Symbol	Type	Bore size
Nil	M5 x 0.8	ø6, ø10, ø16, ø20, ø25
	Rc1/8	ø32
TN	NPT1/8	ø32
TF	G1/8	ø32

Number of auto switches

Nil	2 pcs.
S	1 pc.

Auto switch

Nil	Without auto switch
-----	---------------------

* Refer to the table below for applicable auto switches.
* Auto switches are shipped together but not assembled.

Action

D	Double acting
---	---------------

Cylinder stroke (mm)

ø6, ø10, ø16	40, 50, 60
ø20, ø25, ø32	60, 70, 80, 90, 100

Applicable Auto Switches/Refer to page 68 to 72 for further information on auto switches.

Type	Special function	Electrical entry	Indicator light	Wiring (Output)	Load voltage		Auto switch model		Lead wire length (m)*			Pre-wired connector	Applicable load		
					DC	AC	Perpendicular	In-line	0.5 (Nil)	3 (L)	5 (Z)		IC circuit	Relay, PLC	
															24 V
Reed switch	—	Grommet	Yes	3-wire (NPN equivalent)	—	5 V	—	A96V	A96	●	●	—	—	IC circuit	—
				2-wire	24 V	12 V	100 V	A93V	A93	●	●	—	—	—	IC circuit
Solid state switch	Diagnostic indication (2-color indication)	Grommet	Yes	3-wire (NPN)	24 V	5 V, 12 V	—	M9NV	M9N	●	●	○	○	IC circuit	Relay, PLC
				3-wire (PNP)				M9PV	M9P	●	●	○	○	—	
				2-wire				M9BV	M9B	●	●	○	○	—	
				3-wire (NPN)				F9NWV	F9NW	●	●	○	○	IC circuit	
				3-wire (PNP)				F9PWV	F9PW	●	●	○	○	IC circuit	
				2-wire				F9BWV	F9BW	●	●	○	○	—	

* Lead wire length symbols: 0.5 m.....Nil (Example) M9N
3 m.....L (Example) M9NL
5 m.....Z (Example) M9NZ

* Solid state switches marked with "○" are produced upon receipt of order.

* Normally closed (NC=b contact), solid states switches (Model D-F9G, F9H) are also available.
For detail, refer to page 7-9-23 in Best Pneumatics 2004 Vol. 7 catalog.

* For detail about auto switches with pre-wired connector, refer to page 7-9-36 in the Best Pneumatics 2004 Vol. 7 catalog.

Free Mount Cylinder: Long Stroke Type Non-rotating Rod, Double Acting, Single Rod **Series CUK**

Specifications



Bore size (mm)	6	10	16	20	25	32
Fluid	Air					
Proof pressure	1.05 MPa					
Maximum operating pressure	0.7 MPa					
Minimum operating pressure	0.15 MPa	0.10 MPa	0.08 MPa			
Ambient and fluid temperature	Without auto switch: -10 to 70°C (No freezing) With auto switch: -10 to 60°C (No freezing)					
Lubrication	Non-lube					
Piston speed	50 to 500 mm/s					
Cushion	Rubber bumper					
Rod end thread	Male thread					
Thread tolerance	JIS Class 2					
Stroke length tolerance	$^{+1.0}_0$ mm					
Rod non-rotating accuracy ^{Note)}	$\pm 0.8^\circ$		$\pm 0.5^\circ$			

Note) No load: Rod at retracted

JIS Symbol

Double acting,
Single rod

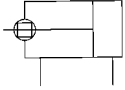

Standard Stroke

(mm)

Bore size (mm)	Standard stroke (mm)
6, 10, 16	40, 50, 60
20, 25, 32	60, 70, 80, 90, 100



Made to Order Specifications (For details, refer to page 43.)

Symbol	Specifications
-XB9	Low speed (10 to 50 mm/s)
-XB13	Low speed (5 to 50 mm/s)
-XC19	Intermediate stroke (with a spacer built-in)

Weight (): Denotes the values with D-A93.

(g)

Model	Stroke (mm)						
	40	50	60	70	80	90	100
C(D)UK6-□D	49 (59)	55 (65)	61 (71)	—	—	—	—
C(D)UK10-□D	71 (81)	79 (89)	87 (97)	—	—	—	—
C(D)UK16-□D	102 (132)	114 (144)	126 (156)	—	—	—	—
C(D)UK20-□D	—	—	243 (284)	267 (308)	291 (332)	315 (356)	339 (380)
C(D)UK25-□D	—	—	405 (460)	440 (495)	475 (530)	510 (565)	545 (600)
C(D)UK32-□D	—	—	617 (695)	669 (747)	721 (799)	773 (851)	825 (903)

* For the auto switch weight, refer to page 68 to 72.

Allowable Rotational Torque

Make sure that rotational torque is not applied to the piston rod of a long stroke type cylinder. If the rotation torque were applied unavoidably, refer to page 22 for details.

Tightening Torque

When mounting a CUK long stroke series, refer to page 3.

Theoretical Output

Specifications are the same as CU series double acting, single rod. Refer to page 3.

Auto Switch Mounting Position

For the auto switch mounting position of CDUK long stroke series, refer to page 6, since specifications are the same as standard type, double acting, single rod type.

Series CUK

Construction

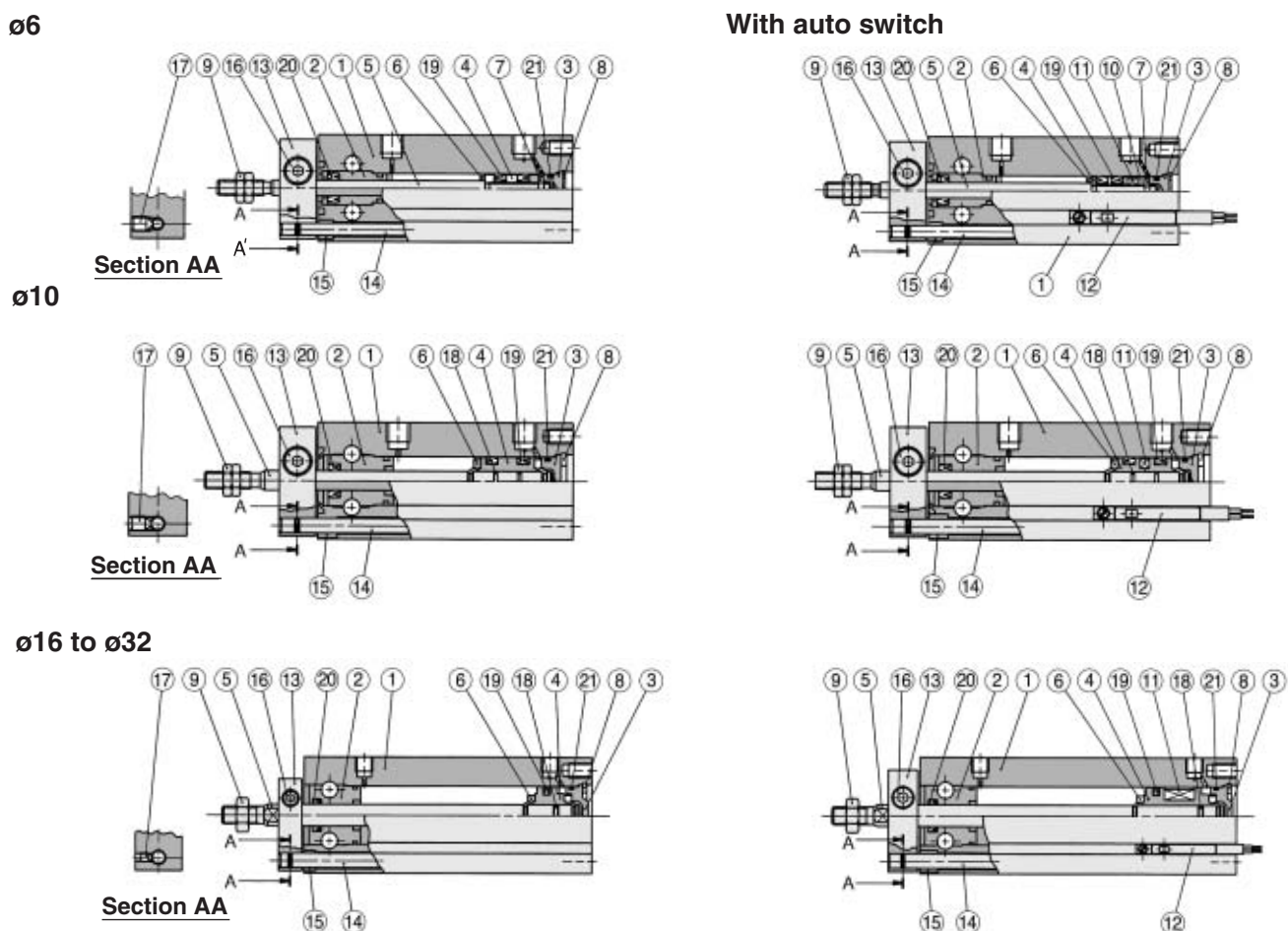

Component Parts

No.	Description	Material	Note
1	Cylinder tube	Aluminum alloy	Hard anodized
2	Rod cover	Aluminum bearing alloy	Hard anodized
3	Head cover	Brass	ø6 to ø10, Electroless nickel plated
		Aluminum alloy	ø16 to ø32, Clear chromated
4	Piston	Brass	ø6 to ø10
		Aluminum alloy	ø16 to ø32, Chromated
5	Piston rod	Stainless steel	
6	Bumper A	Urethane	
7	Bumper B	Urethane	
8	Snap ring	Carbon tool steel	Phosphate coated
9	Rod end nut	Carbon steel	Nickel plated
10	Magnet holder	Brass	ø6

Component Parts

No.	Description	Material	Note
11	Magnet	Magnetic material	
12	Auto switch	—	
13	Non-rotating plate	Aluminum alloy	Nickel plated
14	Guide rod	Stainless steel	
15	Bushing	Oil-impregnated sintered alloy	Black zinc chromated
16	Hexagon socket head cap screw	Carbon steel	Black zinc chromated
17	Hexagon socket head set screw	Carbon steel	
18	Piston gasket	NBR	
19	Piston seal		
20	Rod seal		
21	Gasket		

Replacement Parts: Seal Kit

Bore size (mm)	Kit no.	Contents
10	CU10D-PS	Set of nos. above ⑱, ⑳, ㉑.
16	CU16D-PS	
20	CU20D-PS	
25	CU25D-PS	
32	CU32D-PS	



* Seal kit includes ⑱, ⑳, ㉑. Order the seal kit, based on each bore size.

Dimensions: Non-rotating Rod Type; Double Acting, Single Rod

ø6, ø10

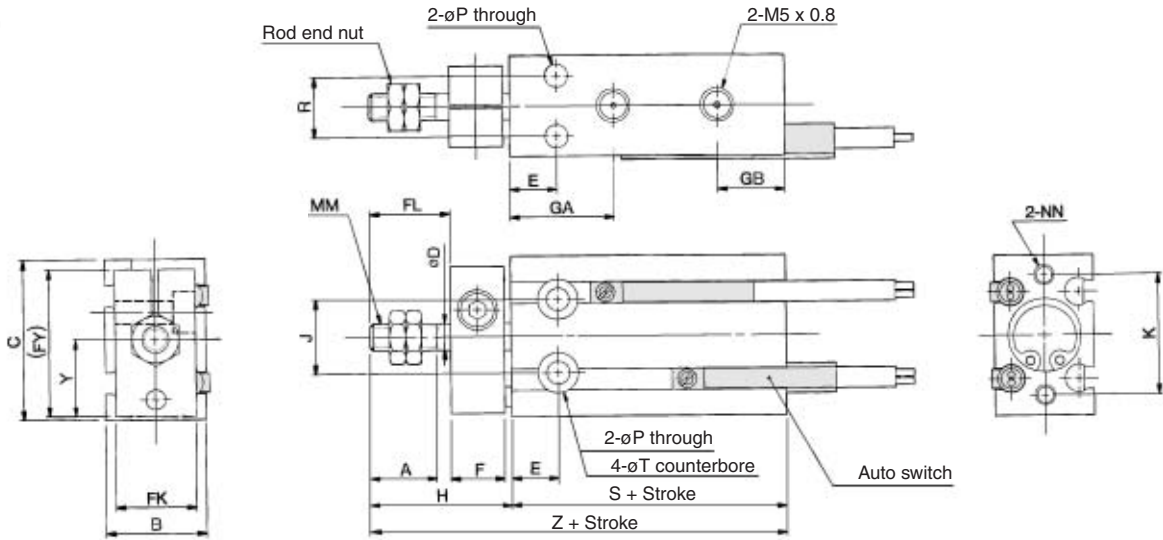

ø16 to ø32

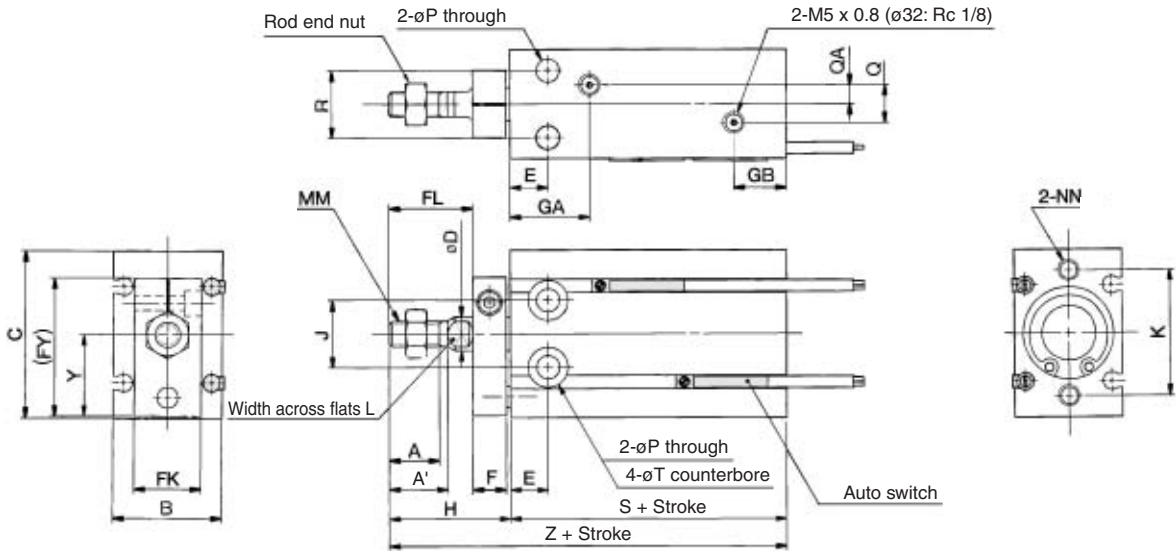

Rod End Nut/Accessory

Material: Carbon steel

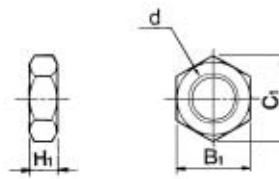

Part no.	Applicable bore size (mm)	d	H ₁	B ₁	C ₁
NTP-006	6	M3 x 0.5	1.8	5.5	6.4
NTP-010	10	M4 x 0.7	2.4	7	8.1
NTJ-015A	16	M5 x 0.8	4	8	9.2
NT-015A	20	M6 x 1.0	5	10	11.5
NT-02	25	M8 x 1.25	5	13	15.0
NT-03	32	M10 x 1.25	6	17	19.6

Bore size (mm)	A	A'	B	C	D	E	F	FL	FK	FY	GA	GB	H	J	K	L	MM
6	7	—	13	22	3	7	8	9	11	20.5	15	10	18	10	17	—	M3 x 0.5
10	10	—	15	24	4	7	8	12	12	22	16.5	10	21	11	18	—	M4 x 0.7
16	11	12.5	20	32	6	7	8	17	13	28	16.5	11.5	26	14	25	5	M5 x 0.8
20	12	14	26	40	8	9	8	20	16	33	19	12.5	29	16	30	6	M6 x 1.0
25	15.5	18	32	50	10	10	10	22	20	43.5	21.5	13	33	20	38	8	M8 x 1.25
32	19.5	22	40	62	12	11	12	29	24	51.5	23	12.5	42	24	48	10	M10 x 1.25

Bore size (mm)	NN	P	Q	QA	R	T	Y	Without auto switch		With auto switch	
								S	Z	S	Z
6	M3 x 0.5 depth 5	3.2	—	—	7	6 depth 4.8	10.5	33	51	33	51
10	M3 x 0.5 depth 5	3.2	—	—	9	6 depth 5	11.5	36	57	36	57
16	M4 x 0.7 depth 6	4.5	4	2	12	7.6 depth 6.5	15.5	30	56	40	66
20	M5 x 0.8 depth 8	5.5	9	4.5	16	9.3 depth 8	19.5	36	65	46	75
25	M5 x 0.8 depth 8	5.5	9	4.5	20	9.3 depth 9	24.5	40	73	50	83
32	M6 x 1.0 depth 9	6.6	13.5	4.5	24	11 depth 11.5	30.5	42	84	52	94



Series CU

Made to Order Specification

-XB6 Heat resistant (150°C)

Enter the applicable model number. —XB6

Applicable Model

CU	Standard, Double acting, Single rod
CUK	Non-rotating rod, Double acting, Single rod
CU	Long stroke, Double acting, Single rod
CUK	Non-rotating rod/Long stroke, Double acting, Single rod

Specifications

Ambient temperature range	-10 to 150°C
Auto switch	Not mountable
Seal material	Fluorine rubber
Grease in use	Heat resistant grease

Specifications other than described above and dimensions are identical to those of standard products.

-XB7 Cold resistant (-40°C)

Enter the applicable model number. —XB7

Applicable Model

CU	Standard, Double acting, Single rod
CUK	Non-rotating rod, Double acting, Single rod
CU	Long stroke, Double acting, Single rod
CUK	Non-rotating rod/Long stroke, Double acting, Single rod

Specifications

Ambient temperature range	-40 to 70°C
Auto switch	Not mountable
Seal material	Low nitrile rubber
Grease in use	Cold resistant grease

Specifications other than described above and dimensions are identical to those of standard products.

-XB9 Low speed (10 to 50 mm/s)

Enter the applicable model number. —XB9

Applicable Model

C(D)U	Standard, Double acting, Single rod
C(D)UK	Non-rotating rod, Double acting, Single rod
C(D)U	Long stroke, Double acting, Single rod
C(D)UK	Non-rotating rod/Long stroke, Double acting, Single rod

-XB13 Low speed (5 to 50 mm/s)

Enter the applicable model number. —XB13

Applicable Model

C(D)U	Standard, Double acting, Single rod
C(D)UK	Non-rotating rod, Double acting, Single rod
C(D)U	Long stroke, Double acting, Single rod
C(D)UK	Non-rotating rod/Long stroke, Double acting, Single rod

-XC19 Intermediate stroke (with a spacer built-in)

Intermediate strokes are available by installing a spacer with 5 mm in width in the standard stroke cylinder.

Enter the applicable model number. —XC19

Applicable Model

C(D)U	Standard, Double acting, Single rod
C(D)UK	Non-rotating rod, Double acting, Single rod
C(D)U	Long stroke, Double acting, Single rod
C(D)UK	Non-rotating rod/Long stroke, Double acting, Single rod

Applicable Stroke

Bore size	Stroke (mm)
6, 10, 16	35, 45, 55
20, 25, 32	35, 45, 55, 65, 75, 85, 95

The external dimension is the same as that of standard products with 5 mm added to strokes above.
Consult with SMC when stroke other than applicable stroke is required.

-XC22 Seals made of fluorine rubber

Seal materials are changed to the fluorine rubber.

Enter the applicable model number. —XC22

Applicable Model

C(D)U	Standard, Double acting, Single rod
	Standard Single acting, Single rod (Retracted/Extended)
C(D)UK	Non-rotating rod, Double acting, Single rod
	Non-rotating rod, Single acting, Single rod (Retracted/Extended)
C(D)U	Long stroke, Double acting, Single rod
C(D)UK	Non-rotating rod/Long stroke, Double acting, Single rod

The other specifications and dimensions are the same as those of standard products.

Series CU



Made to Order Specification

-XC34 Threaded for mounting a work on non-rotating plate (No protrusion from the rod end)

- * Threaded for mounting a work on the plate.
- * "FL" dimension across the non-rotating plate and the piston rod end is removed.
Its piston rod does not stick out of the plate.

Enter the applicable model number. —XC34

Applicable Model

C(D)UK	Non-rotating rod, Double acting, Single rod
	Non-rotating rod, Single acting, Single rod (Retracted/Extended)
	Non-rotating rod/Long stroke, Double acting, Single rod

Dimensions

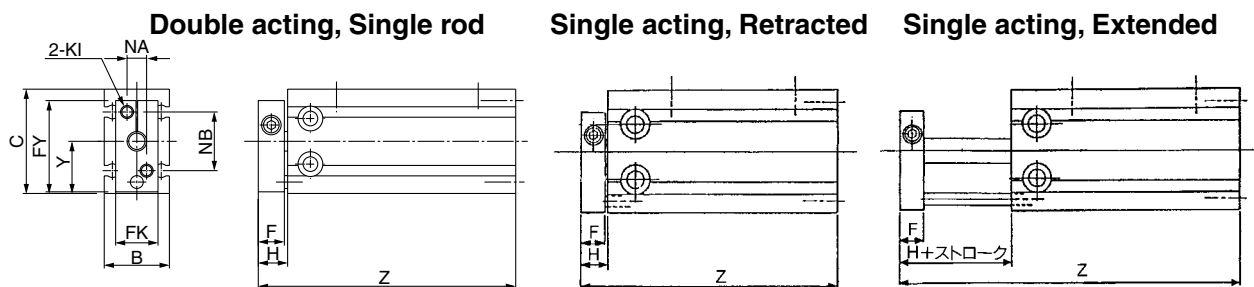

(mm)

Bore size (mm)	B	C	FK	FY	KI	NA	NB	Y
6	13	22	11	20.5	M3 x 0.5	6	14	10.5
10	15	24	12	22	M3 x 0.5	7	15	11.5
16	20	32	13	28	M4 x 0.7	6	18	15.5
20	26	40	16	33	M4 x 0.7	8	20	19.5
25	32	50	20	43.5	M5 x 0.8	10	28	24.5
32	40	62	24	51.5	M5 x 0.8	12	32	30.5

(mm)

Bore size (mm)	Action	F	H	Double acting		Single acting, Retracted						Single acting, Extended					
				Z		Z						Z					
				Without auto switch	With auto switch	Without auto switch			With auto switch			Without auto switch			With auto switch		
						5	10	15	5	10	15	5	10	15	5	10	15
6		8	9	42	42	47	52	57	47	52	57	52	62	67	52	62	67
10		8	9	45	45	50	55	65	50	55	65	55	65	80	55	65	80
16		8	9	39	49	44	49	59	54	59	69	59	69	84	69	79	94
20		8	9	45	55	50	55	65	60	65	75	55	65	80	65	75	90
25		10	11	51	61	56	61	71	66	71	81	61	71	86	71	81	96
32		12	13	55	65	60	65	75	70	75	85	65	75	90	75	85	100

* The dimensions other than the table above are the same as those of standard type.

Related Products

For details, refer to the respective catalog.

Clean Series

10-CDU
11-CDU

Compliant with clean environment



Specifications

Model	10-CDU (Relief type) 11-CDU (Vacuum type)		
	Bore size (mm)	6	10, 16
Proof pressure	1.05 MPa		
Max. operating pressure	0.7 MPa		
Min. operating pressure	0.12 MPa	0.06 MPa	0.05 MPa
Ambient and fluid temperature	Without auto switch: -10 to 70°C With auto switch: -10 to 60°C (with no freezing)		
Operating piston speed	50 to 400mm/s		
Allowable margin of stroke length	+1.0 0		
Grease in use	Fluoro grease		
Grade of particle generation amount	10-: Grade 2 11-: Grade 1		

Copper/Fluorine/Silicon-based free + Low Particle Generation

21-CDU
22-CDU

Compliant with the environment where no copper, fluorine and silicon are allowed and with clean environment.



Specifications

Model	21-CDU (Relief type) 22-CDU (Vacuum type)		
	Bore size (mm)	6	10, 16
Proof pressure	1.05 MPa		
Max. operating pressure	0.7 MPa		
Min. operating pressure	0.12 MPa	0.06 MPa	0.05 MPa
Ambient and fluid temperature	Without auto switch: -10 to 70°C With auto switch: -10 to 60°C (with no freezing)		
Operating piston speed	50 to 400 mm/s		
Allowable margin of stroke length	+1.0 0		
Grease in use	Lithium soap-based grease		
Grade of particle generation amount	21-: Grade3 22-: Grade1		

Low Speed

C(D)UX

Stable low speed actuation even at 0.5 mm/s (ø16 or less: 1 mm/s)



Specifications

Proof pressure	1.05MPa
Max. operating pressure	0.7MPa
Ambient and fluid temperature	Without auto switch: -10 to 70°C With auto switch: -10 to 60°C (with no freezing)
Lubrication	Not required (Non-lube)
Operating piston speed	ø10, ø16: 1 to 300mm/s ø20 to ø32: 0.5 to 300mm/s
Cushion	Rubber bumper on both ends
Rod end thread	Male thread
Thread tolerance	JIS Class 2
Allowable margin of stroke length	Note) +1.0 0
Mounting	Basic style

Note) Tolerance +1.0
0

Minimum Operating Pressure

Unit: MPa

Bore size (mm)	10	16	20	25	32
Minimum operating pressure (MPa)	0.06	0.06	0.05	0.05	0.05

Free Mount Cylinder with Air Cushion

Series CU

New air cushion mechanism



Free mount cylinder *Series CU* now employs an air cushion mechanism.

Extended dimensions (compared to the standard *CU* models) are hardly noticeable.

(with rubber bumper)

- Overall length: **+1.5 to 7 mm**
- Overall height: **+0 to 2 mm** ↑
No air cushion protrusion!
- Overall width: not affected

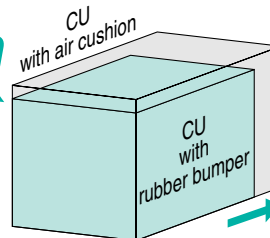

Bore size	Extended dimensions (mm)	
	Length	Height
ø20	7	2
ø25	1.5	0
ø32	4	0

New
AIR CUSHION

Unique air cushion construction requires no cushion ring.

Elimination of the cushion ring used in conventional type air cushions has made it possible to reduce the overall length of the cylinder while retaining all the advantages of a compact profile.

Working principle

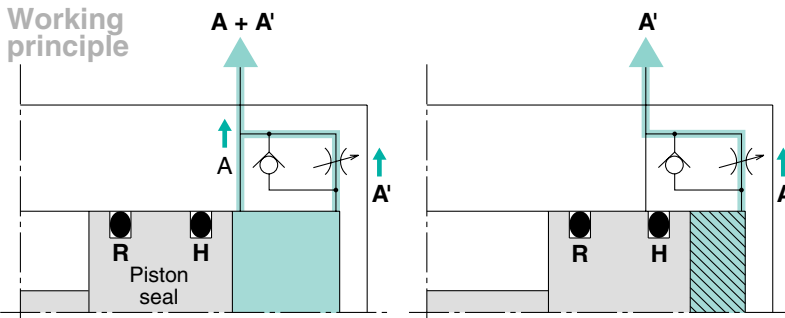

- ① When the piston is retracting, air is exhausted through both A and A' until piston seal H passes air passage A.
- ② After piston seal H has passed air passage A, air is exhausted only through A'. The section marked with slanted lines becomes a cushion chamber, and an air cushion effect is achieved.
- ③ When air is supplied for the piston extension, the check valve opens and the piston extends with no delay.

Reduced stroke end impact and noise: New standards to meet consumer demand.

Free mounting

3 types of mounting orientations can be accommodated depending on the installation conditions.

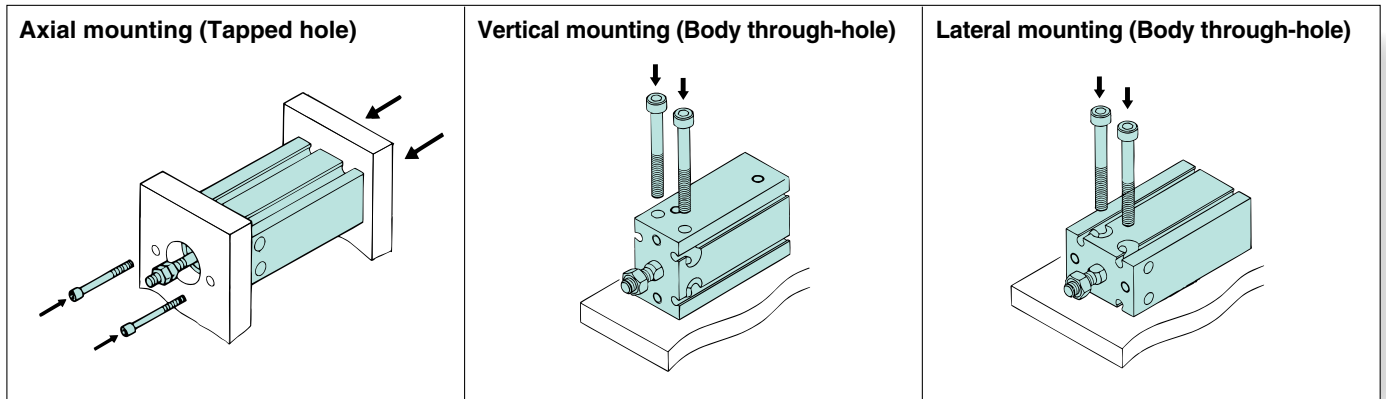

Approximately 2.4 times of allowable kinetic energy

(Compared to the old Series CU with rubber bumper)

Improved allowable kinetic energy absorption.

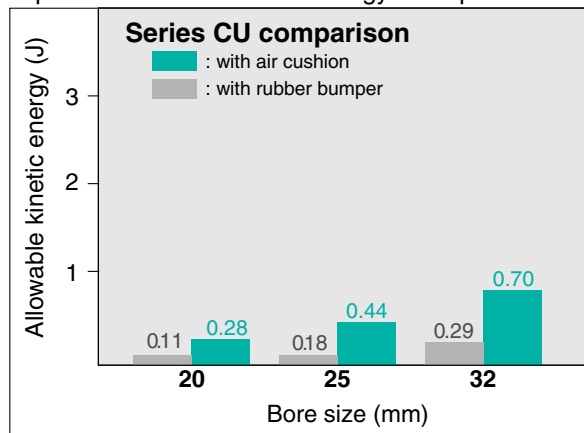

Improved sound insulation (Reduced impact noise at the stroke end)

- Noise reduction of more than 11dB is possible (compared to Series CU20 with rubber bumper).

Interchangeable mounting

Mounting dimensions (J, K, R, and E) are the same as the rubber bumper type Series CU.

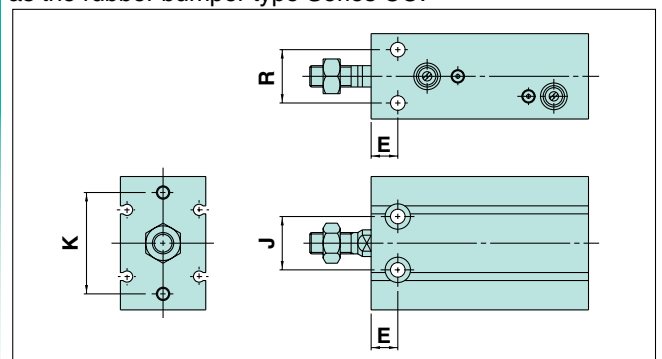

Improved repeatability

When compared to rubber bumper type actuators, air cushion type cylinders are less likely to be affected by pressure fluctuations, and therefore better able to achieve a stable and smooth stroke.

Size Variations

Model	Standard stroke										Auto switch
	20	30	40	50	60	70	80	90	100		
C(D)U20	●	●	●	●	●	●	●	●	●	●	• ø20 to ø32 Direct mounting style auto switch
C(D)U25	●	●	●	●	●	●	●	●	●	●	
C(D)U32	●	●	●	●	●	●	●	●	●	●	

Free Mount Cylinder with Air Cushion

Series CU

ø20, ø25, ø32

How to Order

Without auto switch

CU 32 50 **A**

With auto switch

CDU 32 50 **A** M9B

Built-in magnet

Bore size

20	20 mm
25	25 mm
32	32 mm

Thread type

Symbol	Type	Bore size
Nil	M thread	ø20, ø25
	Rc	
TN	NPT	ø32
TF	G	

Number of auto switches

Nil	2 pcs.
S	1 pc.

Auto switch

Nil	Without auto switch
-----	---------------------

* Refer to the table below for applicable auto switches.
* Auto switches are shipped together but not assembled.

Air cushion

A	With air cushion
---	------------------

Cylinder stroke (mm)
Refer to next page for "Standard Stroke".

Applicable Auto Switches/Refer to page 68 to 72 for further information on auto switches.

Type	Special function	Electrical entry	Indicator light	Wiring (output)	Load voltage		Auto switch model		Lead wire length (m)*			Pre-wired connector	Applicable load		
					DC	AC	Perpendicular	In-line	0.5 (Nil)	3 (L)	5 (Z)				
Reed switch	—	Grommet	Yes	3-wire (NPN equivalent)	—	5 V	—	A96V	A96	●	●	—	—	IC circuit	—
				2-wire	24 V	12 V	100 V	A93V	A93	●	●	—	—	—	Relay PLC
Solid state switch	Diagnostic indication (2-color indication)	Grommet	Yes	3-wire(NPN)	24 V	5 V, 12 V	100 V or less	M9NV	M9N	●	●	○	○	IC circuit	Relay PLC
				3-wire(PNP)				M9PV	M9P	●	●	○	○		
				2-wire	M9BV	M9B	●	●	○	○	—				
				3-wire(NPN)	F9NWV	F9NW	●	●	○	○	IC circuit				
				3-wire(PNP)	F9PWV	F9PW	●	●	○	○	—				
				2-wire	F9BWV	F9BW	●	●	○	○	—				

* Lead wire length symbols: 0.5 m.....Nil (Example) M9N
 3 m.....L (Example) M9NL
 5 m.....Z (Example) M9NZ

Note) Solid state switches marked "○" are produced upon receipt of order.

* Normally closed (NC=b contact), solid state switches (Model D-F9G, F9H) are also available.
 For detail, refer to page 7-9-23 in the Best Pneumatics 2004 Vol. 7 catalog.
 * For detail about auto switches with pre-wired connector, refer to page 7-9-36 in the Best Pneumatics 2004 Vol. 7 catalog.

Series CU



Specifications

Type	Pneumatic (Non-lube)
Fluid	Air
Proof pressure	1.0 MPa
Maximum operating pressure	0.7 MPa
Minimum operating pressure	0.08 MPa
Ambient and fluid temperature	Without auto switch: -10°C to 70°C (No freezing) With auto switch: -10°C to 60°C (No freezing)
Rod end thread	Male thread
Rod end thread tolerance	JIS Class 2
Stroke length tolerance	$\begin{matrix} +1.0 \\ 0 \end{matrix}$
Piston speed	50 to 500 mm/s

Effective Cushion Length

Bore size (mm)	20	25	32
Effective cushion length (mm)	6.6	6.7	7.7

Standard Stroke

Bore size (mm)	Standard stroke (mm)
20, 25, 32	20, 30, 40, 50, 60, 70, 80, 90, 100

* Intermediate strokes are also available upon receipt of order. Please contact SMC.
Minimum stroke length is 20 mm.

When mounting Series CU refer to the table below.

Bore size (mm)	Hexagon socket head cap screw size (mm)	Proper tightening torque (N·m)
20, 25	M5	5.10 ±10%
32	M6	8.04 ±10%

Allowable Kinetic Energy

Refer to "Selection" on P.54 regarding allowable kinetic energy.

Theoretical Output

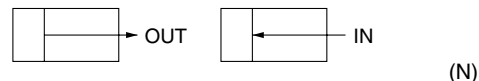

Bore size (mm)	Operating direction	Operating pressure (MPa)		
		0.3	0.5	0.7
20	OUT	94.2	157	220
	IN	79.2	132	185
25	OUT	147	246	344
	IN	124	206	288
32	OUT	241	402	563
	IN	207	346	454

Weight

Basic Weight

Bore size (mm)	Standard stroke (mm)									
	20	30	40	50	60	70	80	90	100	
20	186	208	230	252	274	296	318	340	362	
25	289	323	357	391	425	459	493	527	561	
32	464	512	560	608	656	704	752	800	848	

Additional Weight

Bore size (mm)	Magnet
20	5
25	6
32	11

Construction

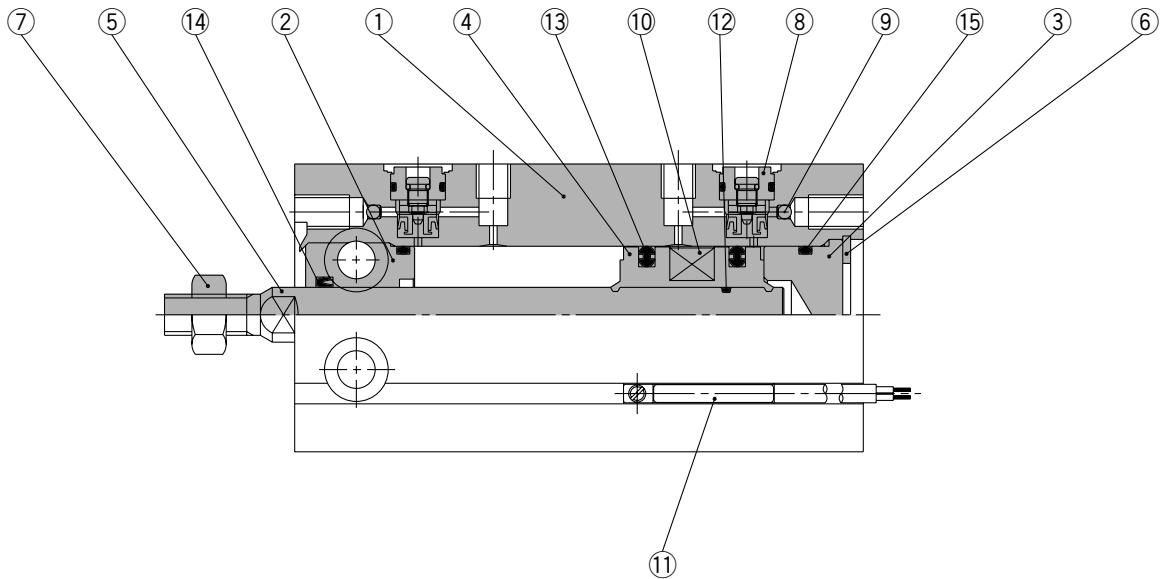

Component Parts

No.	Description	Material	No. of pcs.	Note
1	Cylinder tube	Aluminum alloy	1	Hard anodized
2	Rod cover/Bearing	Aluminum bearing alloy	1	Hard anodized
3	Head cover	Aluminum alloy	1	Clear chromated
4	Piston	Aluminum alloy	1	Chromated
5	Piston rod	Stainless steel	1	
6	Snap ring	Carbon tool steel	1	Phosphate coated
7	Rod end nut	Carbon steel	1	Nickel plated
8	Cushion needle assembly	—	(2)	
9	Steel ball	Carbon steel	2	
10	Magnet	Magnetic material	1	
11	Auto switch	—	(2)	D- $\frac{1}{2}$ 9□ type
12	Piston gasket	NBR	1	
13	Piston seal	NBR	2	
14	Rod seal	NBR	1	
15	Gasket	NBR	1	

Replacement Parts: Seal Kit

Bore size (mm)	Kit no.	Contents
ø20	CU20A-PS	13, 14, and 15
ø25	CU25A-PS	
ø32	CU32A-PS	

Series CU

Dimensions

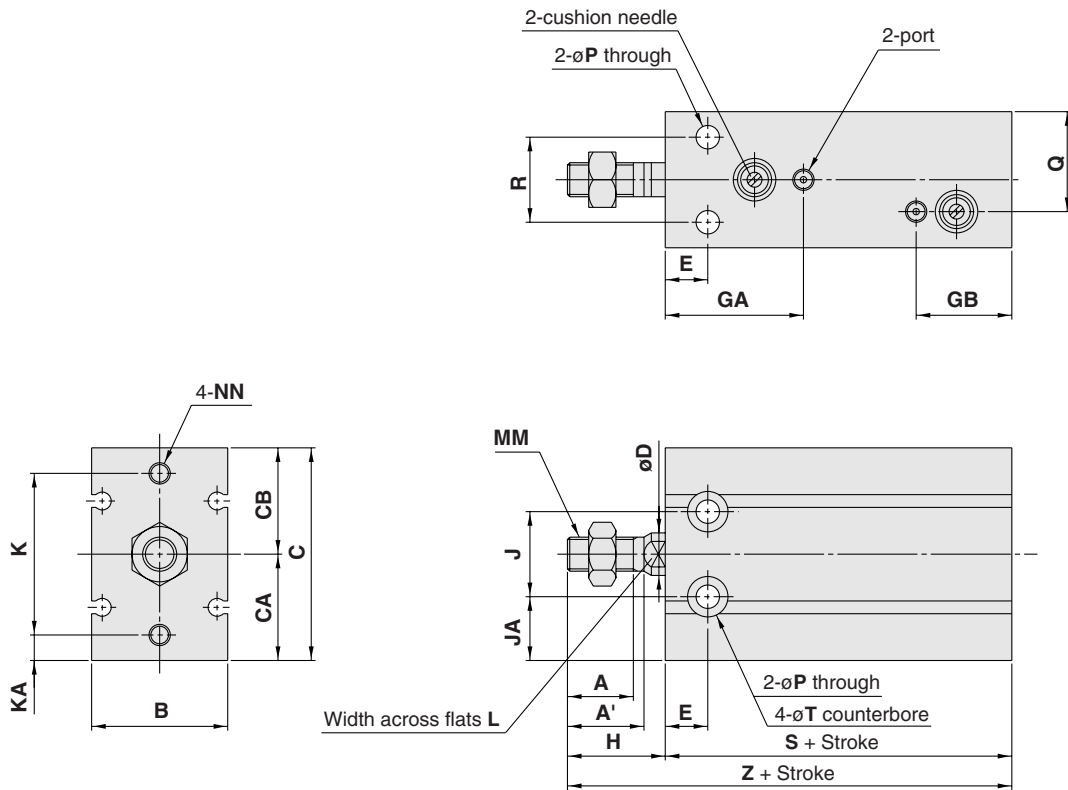

(mm)

Bore size (mm)	Port size	A	A'	B	C	CA	CB	D	E	GA	GB	H	J	JA
20	M5 x 0.8	12	14	26	42	20	22	8	9	29	27	19	16	12
25	M5 x 0.8	15.5	18	32	50	25	25	10	10	32.5	22.5	23	20	15
32	Rc1/8	19.5	22	40	62	31	31	12	11	35	25	27	24	19

Bore size (mm)	K	KA	L	MM	NN	P	Q	R	T	S	Z	Standard stroke
20	30	5	6	M6 x 1.0	M5 x 0.8 with depth 8	5.5	13	16	9.3 with depth 8	53	72	20, 30, 40, 50, 60, 70, 80, 90, 100
25	38	6	8	M8 x 1.25	M5 x 0.8 with depth 8	5.5	23.5	20	9.3 with depth 9	51.5	74.5	
32	48	7	10	M10 x 1.25	M6 x 1.0 with depth 9	6.6	29	24	11 with depth 11.5	56	83	

Proper Auto Switch Mounting Position (Detection at stroke end) and Its Mounting Height

D-A9□
D-M9□
D-F9□W

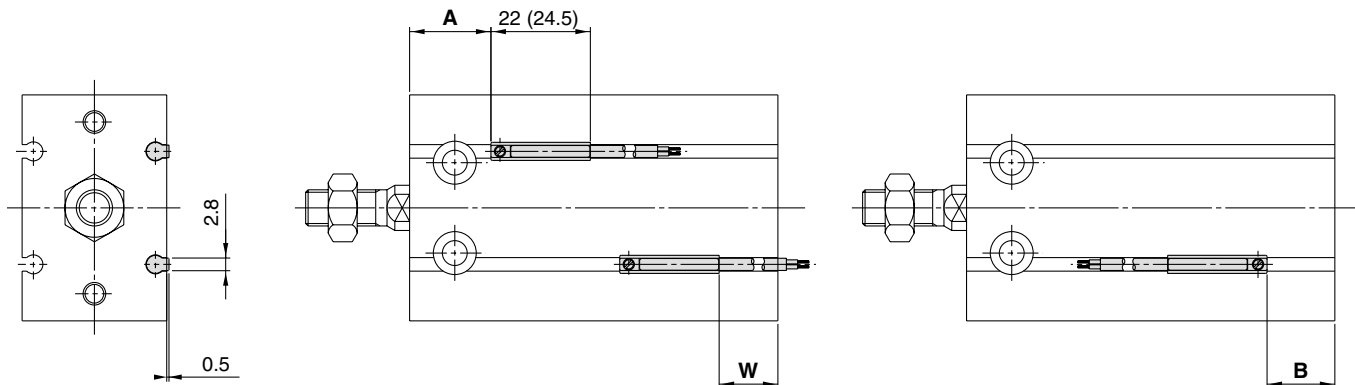

(): Denotes the values of D-A93.

D-A9□V
D-M9□V
D-F9□WV

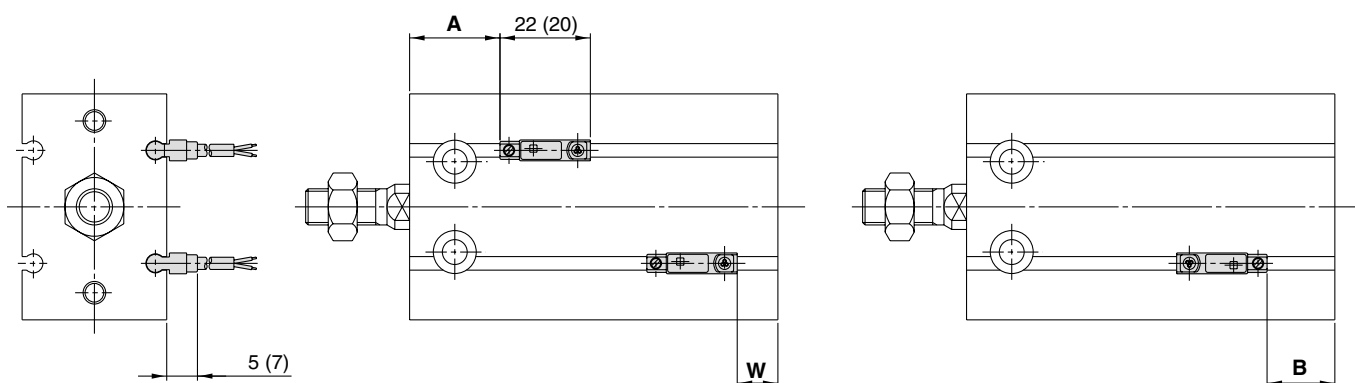

(): Denotes the values of D-M9□V, D-F9□WV.

Bore size (mm)	D-A9□, D-A9□V			D-M9□, D-F9□W			D-M9□V, D-F9□WV		
	A	B	W	A	B	W	A	B	W
20	18	15	13 (10.5)	22	19	9	22	19	11
25	20	11	9 (6.5)	24.5	15	5	24.5	15	7
32	22.5	13.5	11.5 (9)	26.5	17.5	7.5	26.5	17.5	9.5

Note 1) Figures in the table above are used as a reference when mounting the auto switches for stroke end detection. In the case of actually setting the auto switches, adjust them after confirming their operation.

Note 2) Values in () are dimensions for D-A93 type.

Operating Range

Switch model	Bore size (mm)		
	20	25	32
D-A9□, D-A9□V	11	12.5	14
D-M9□, D-M9□V	5	5	5
D-F9□W, D-F9□WV	6.5	7	7

* Values in this table include hysteresis and are to be used as a guide only. They do not guarantee an actual fixed range (expect approximately $\pm 30\%$ dispersion). Values may vary greatly depending on the operating environment.

Series CU

Auto Switch Rail Position

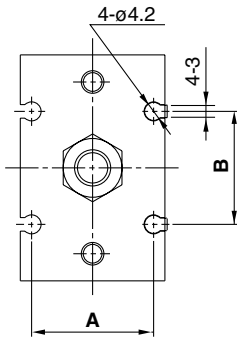

Bore size (mm)	A	B
20	21	23
25	27	25
32	35	27

(mm)

Caution on Proximity Installation

When free mounting cylinders equipped with auto switches are used, the auto switches could activate unintentionally if the installed distance is less than the dimensions shown in the table. Therefore, make sure to provide a greater clearance. Due to unavoidable circumstances, if they must be used with less distance than the dimensions given in the table, the cylinders must be shielded. Therefore, affix a steel plate or a magnetic shield plate (MU-S025) to the area on the cylinder that corresponds to the adjacent auto switch. (Please contact SMC for details.) Auto switches may malfunction if a shield plate is not used.

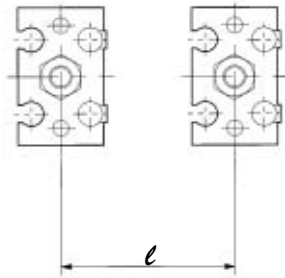

Bore size (mm)	Mounting pitch l (mm)
20	40
25	46
32	56



Series CU

Specific Product Precautions 1

Be sure to read before handling. Refer to back page 1 through to 6 for Safety Instructions, Actuator Precautions, and Auto Switch Precautions.

Installation and Removal of Snap Rings

⚠ Caution

1. Use appropriate pliers (Type C snap ring installing tool) for installation and removal of snap rings.
2. Even when using appropriate pliers (Type C snap ring installing tool), proceed with caution as there is a danger of the snap ring flying off the end of the pliers (tool) and causing bodily injury or damage to nearby equipment. After installation, make sure that the snap ring is securely seated into the snap ring groove before supplying air.

Mounting

⚠ Caution

1. Refer to the below table for mounting cylinders.

Tightening Torque

Bore sizes (mm)	Hexagon socket head cap screw (mm)	Proper tightening torque (N·m)
20, 25	M5	5.10 ±10%
32	M6	8.04 ±10%

Selection

⚠ Caution

1. Operate the cylinder to the stroke end.
When the stroke is restricted by an external stopper or a clamped workpiece, sufficient cushioning and noise reduction may not be achieved.
2. Strictly observe the limiting ranges for load weight and maximum speed (Graph (1)). Also, the limiting ranges provided here are based on the condition that the cylinder is operated to the stroke end with a proper cushion needle adjustment.

If operated beyond the limiting ranges, excessive impact will occur and this may cause damage to equipment.

Graph (1)

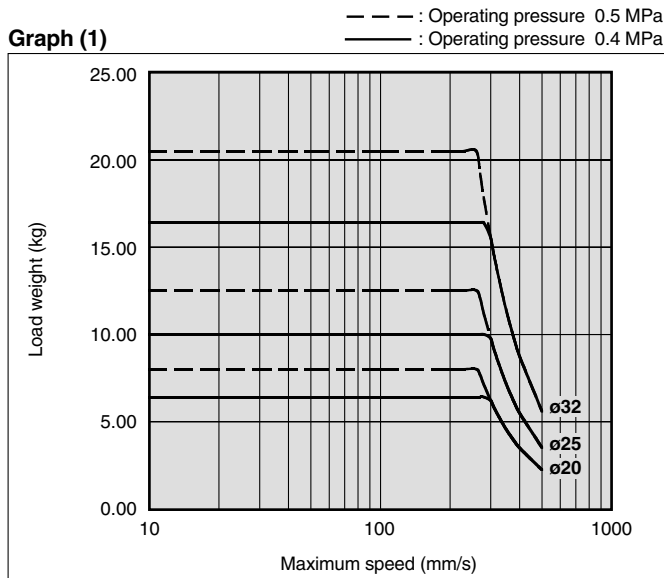

Selection

⚠ Caution

3. Adjust the cushion needle to reduce excessive kinetic energy from the piston impact at the stroke end by allowing it to absorb sufficient kinetic energy during the cushion stroke.

If due to improper adjustment, the piston impacts the stroke end with excessive kinetic energy (values above those given in Table (1)), an excessive impact will occur and this may cause damage to equipment.

Table (1) Allowable Kinetic Energy at Piston Impact (J)

	20	25	32
Piston speed	50 to 500 mm/s		
Allowable kinetic energy	0.055	0.09	0.15

4. Strictly observe the limiting ranges for the piston rod lateral load (Graph (2)).

If operated beyond the limiting ranges, equipment life may be reduced or damage to equipment may occur.

Piston Rod Lateral Load (Graph (2))

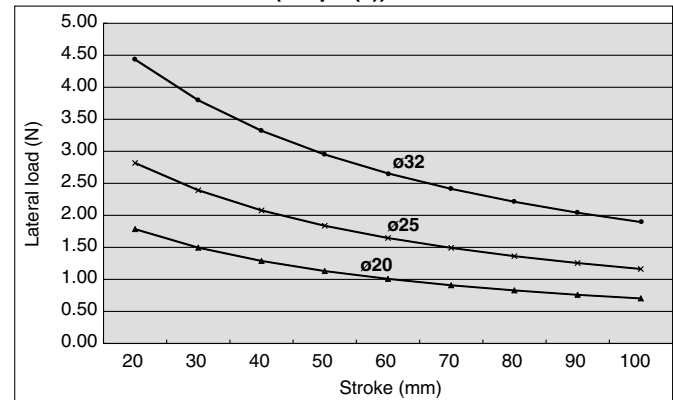

Cushion Needle Adjustment

⚠ Caution

1. Keep the adjustment range for the cushion needle between the fully closed position and the rotations shown below.

	Rotations
ø20 to ø32	2.5 rotations or less

Use a 3 mm flat head watchmakers' screwdriver to adjust the cushion needle. The adjustment range for the cushion needle must be between the fully closed position and the open position ranges indicated in the above table. A retaining mechanism prevents the cushion needle from slipping out; however, it may spring out during operation if it is rotated beyond the ranges shown above.

Free Mount Cylinder for Vacuum

Series ZCUK

A free mount cylinder with a vacuum passage in the rod to meet the requirements for

Air cylinder + **Vacuum pad**.

A vacuum passage has been provided in the rod of the CUK cylinder to enable a vacuum pad to be installed on the end of the rod.



Not necessary to provide vacuum tubing space at the end of the rod.

The area around the vacuum pad is uncluttered.

● Non-rotating rod ●

A guide is provided as standard equipment

Non-rotating rod accuracy (no load: when the rod is retracted on the detent plate side):
 $\phi 10, \phi 16$ $\pm 0.8^\circ$
 $\phi 20, \phi 25, \phi 32$ $\pm 0.5^\circ$

Do not apply a lateral load to the piston rod. Because the piston rod is a hollow rod, a lateral load can cause the piston rod to bend or break.

● Vacuum pad (Pad diameter: $\phi 2$ to $\phi 50$) ●

<Perpendicular female thread>

<Male thread>

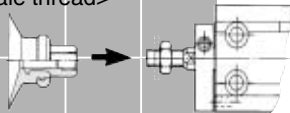

<Direct mounting>

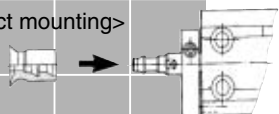

<Barb fitting>

● Auto switch

Reed switch:

D-A9□ (Heavy-duty cord, in-line entry)

D-A9□V (Heavy-duty cord, perpendicular entry)

Solid state switch:

D-M9□, D-F9□W (Heavy-duty cord, in-line entry)

D-M9□V, D-F9□WV (Heavy-duty cord, perpendicular entry)

● How to provide piping to the vacuum side

Cap piping

The piston rod of the vacuum side does not protrude. Also, the vacuum outlet tube does not move when the piston is operating.

Vacuum port pressure range: -101 kPa to 0.6 MPa
 Pressurize only when releasing the vacuum. At that time, use it under the cylinder operating pressure.

Rod piping

Lighter weight than the cap piping.

Can also be used for air blowing.

Vacuum port pressure range: -101 kPa to 0.6 MPa



Free Mount Cylinder for Vacuum Series ZCUK



How to Order

Without auto switch ZCUK C 16 [] 20 D

With auto switch ZCDUK C 16 [] 20 D - M9B S

Number of auto switches
 Nil — 2 pcs.
 S — 1 pc.

Built-in magnet
Style (Tubing method in vacuum side)/ (Rod end shape)
 C — Cap piping/Male thread
 D — Cap piping/Pad direct mounting
 Q — Rod piping/Male thread
 R — Rod piping/ Pad direct mounting

Bore size
 10 — 10 mm
 16 — 16 mm
 20 — 20 mm
 25 — 25 mm
 32 — 32 mm

Port thread type

Symbol	Type	Bore size
Nil	M5 x 0.8	ø10, ø16, ø20, ø25
	Rc1/8	ø32
TN	NPT1/8	ø32
TF	G1/8	ø32

Auto switch
 Nil Without auto switch

Acting
 D — Double acting

Bore size – Stroke (mm)
 10, 16 — 5, 10, 15, 20, 25, 30
 20, 25, 32 — 5, 10, 15, 20, 25, 30, 40, 50

Note) In the case of rod piping (Q, R), TF (G1/8) is not available.

Applicable Auto Switch/Refer to page 68 to 72 for further information on auto switches.

Type	Special function	Electrical entry	Indicator/light	Wiring (Output)	Load voltage		Auto switch model		Lead wire length (m)*			Pre-wired connector	Applicable load		
					DC	AC	Perpendicular	In-line	0.5 (Nil)	3 (L)	5 (Z)		IC circuit	Relay, PLC	
Reed switch	—	Grommet	Yes	3-wire (NPN equivalent)	—	5 V	—	A96V	A96	●	●	—	—	IC circuit	—
				2-wire	24 V	12 V	100 V	A93V	A93	●	●	—	—	—	—
Solid state switch	Diagnostic indication (2-color indication)	Grommet	Yes	3-wire (NPN)	24 V	5 V, 12 V	—	M9NV	M9N	●	●	○	○	IC circuit	Relay, PLC
				3-wire (PNP)				M9PV	M9P	●	●	○	○	—	
				2-wire	12 V	M9BV	M9B	●	●	○	○	—			
				3-wire (NPN)	5 V, 12 V	F9NWV	F9NW	●	●	○	○	IC circuit			
				3-wire (PNP)	5 V, 12 V	F9PWV	F9PW	●	●	○	○	—			
				2-wire	12 V	F9BWV	F9BW	●	●	○	○	—			

* Lead wire length symbols: 0.5 m.....Nil (Example) M9N
 3 m.....L (Example) M9NL
 5 m.....Z (Example) M9NZ

* Solid state switches marked with "○" are produced upon receipt of order.

* Normally closed (NC=b contact), solid states switches (Model D-F9G, F9H) are also available. For detail, refer to page 7-9-23 in Best Pneumatics 2004 Vol. 7 catalog.
 * For detail about auto switches with pre-wired connector, refer to page 7-9-36 in the Best Pneumatics 2004 Vol. 7 catalog.

How to Order Vacuum Pad

Note) Refer to page 58 for combination of cylinder and pad.

<In the case of rod end male>

ZPT 02 U N - B4

Dia. (mm)
 02 — ø2
 04 — ø4
 06 — ø6
 08 — ø8
 10 — ø10
 13 — ø13
 16 — ø16
 20 — ø20
 25 — ø25
 32 — ø32
 40 — ø40
 50 — ø50

Pad type
 U — Flat
 C — Flat with ribs
 D — Deep
 B — Bellows

Vacuum entry (Mounting thread diameter)

Symbol	Thread dia.	ø2 to ø8	ø10 to ø16	ø20 to ø32	ø40, ø50
B4	M4 x 0.7	●	—	—	—
B5	M5 x 0.8	●	●	—	—
B6	M6 x 1	—	●	●	—
B8	M8 x 1.25	—	—	●	●
B10	M10 x 1.25	—	—	●	●

Material
 N — NBR
 S — Silicon rubber
 U — Urethane rubber
 F — Fluoro rubber
 GN — Conductive NBR (ø2 to ø16 only)
 GS — Conductive silicon rubber (ø2 to ø16 only)

Table (1) Pad Dia./Pad Type

Dia. (mm)	2	4	6	8	10	13	16	20	25	32	40	50
Flat	●	●	●	●	●	●	●	●	●	●	●	●
Flat with ribs	—	—	—	—	●	●	●	●	●	●	●	●
Deep	—	—	—	—	●	—	●	—	●	—	●	—
Bellows	—	—	●	●	●	●	●	●	●	●	●	●

<In the case of pad direct mounting>

ZP 04 U N - X11

Dia. (mm)
 02 — ø2
 04 — ø4
 06 — ø6
 08 — ø8
 10 — ø10
 13 — ø13
 16 — ø16
 20 — ø20
 25 — ø25
 32 — ø32
 40 — ø40
 50 — ø50

Pressure gauge position

Symbol	Applicable cylinder model
X11	ZC(D)UK _R 10
Nil	ZC(D)UK _R 16/32

Note) "X11" Pad: ø2 to ø8 diameter and flat style only available.

Material
 N — NBR
 S — Silicon rubber
 U — Urethane rubber
 F — Fluoro rubber
 GN — Conductive NBR (ø2 to ø16 only)
 GS — Conductive silicon rubber (ø2 to ø16 only)

Pad type
 U — Flat
 C — Flat with ribs
 D — Deep
 B — Bellows (Except "-X11")

Series ZCUK

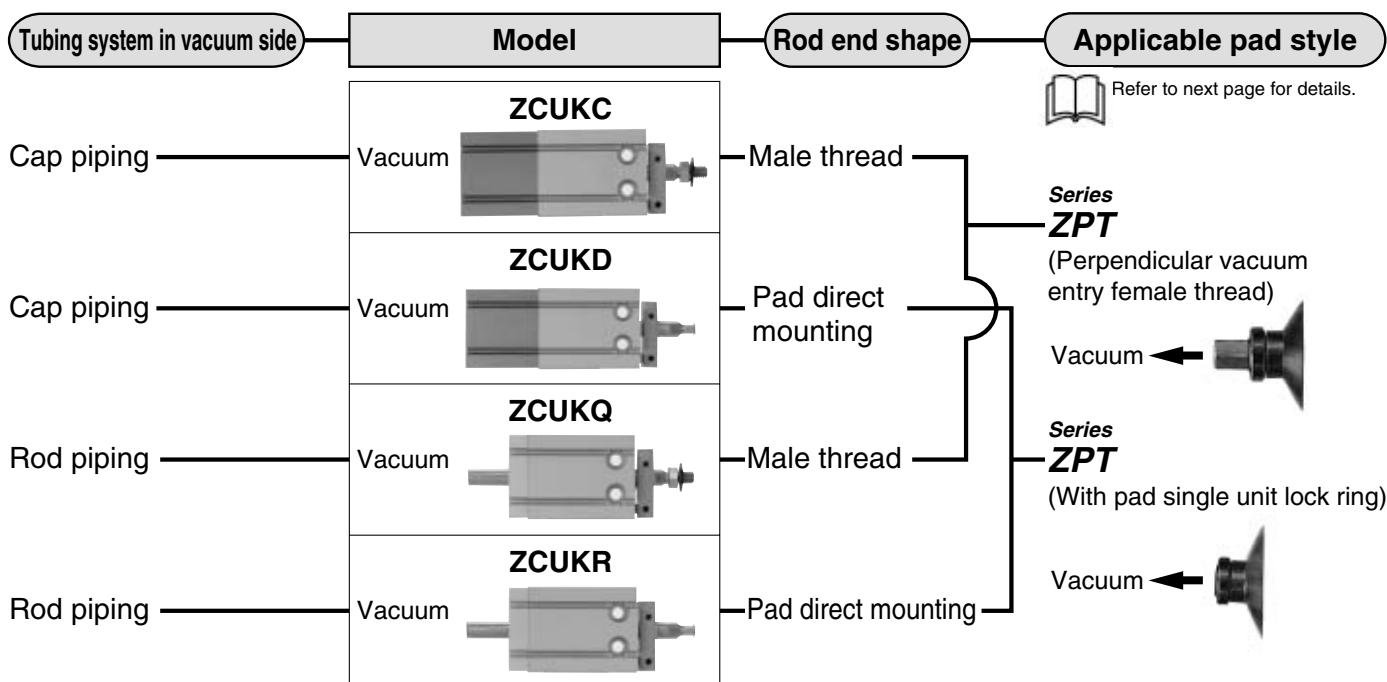

⚠ Precautions

Be sure to read before handling. Refer to back page 1 through to 6 for Safety Instructions, Actuator Precautions and Auto Switch Precautions. Also see page 13-1-5 for Vacuum Equipment Precautions in the Best Pneumatics 2004 Vol. 13 catalog.

⚠ Caution

- Do not place your finger in the clearance between the detent plate and the cylinder tube.

Never put your finger between the non-rotating plate and cylinder tube. Your finger may be pinched when the piston rod retracts.

If your finger is caught, it could injure your finger because the cylinder outputs a considerable amount of force.

- Make sure that rotational torque is not applied to the piston rod. If this is unavoidable, operate the cylinder within the allowable rotational torque listed in the table below.

Allowable Rotational Torque

Bore size (mm)	ø10	ø16	ø20	ø25	ø32
Allowable rotational torque (N-m)	0.02	0.04	0.10	0.15	0.20

- To secure a workpiece to the end of the piston rod, tighten the workpiece onto the piston rod with the piston rod fully retracted so that torque is not applied to the piston rod.
- To install a cylinder, tighten it within the torque values indicated in the table below.

Proper Tightening Torque

Bore size (mm)	Hexagon socket head bolt diameter (mm)	Proper tightening torque (N-m)
ø10	M3	1.08 ±10%
ø16	M4	2.45 ±10%
ø20, ø25	M5	5.10 ±10%
ø32	M6	8.04 ±10%

Specifications

Fluid	Air
Proof pressure	1.05 MPa
Maximum operating pressure	0.7 MPa
Vacuum port pressure	-101 kPa to 0.6 MPa (At vacuum release 0 to 0.6 MPa) ^{Note)}
Ambient and fluid temperature	Without auto-switch: -10 to +70°C (No freezing) With auto-switch: -10 to +60°C (No freezing)
Lubrication	Not required
Piston speed	50 to 500mm/s
Cushion	Rubber bumper on both sides
Stroke allowance	+1.0 0
Thread tolerance	JIS Class 2
Rod tip screw	With or without (Pad direct mounting)
Mounting	Basic style
Applicable pad	Refer to next page for details.



Note) For a cap style, supply pressure only when vacuum is released. That pressure should be less than the cylinder pressure.

Non-rotating Rod Accuracy (No load/At retraction of the rod at the locking plateside)

Bore size (mm)	ø10	ø16	ø20	ø25	ø32
Non-rotating rod accuracy	±0.8°		±0.5°		

Minimum Operating Pressure

Bore size (mm)	ø10	ø16	ø20	ø25	ø32
Min. Operating Pressure (MPa)	0.13	0.13	0.11	0.11	0.11

Free Mount Cylinder for Vacuum *Series ZCUK*

Standard Stroke

Applicable cylinder Stroke (mm)	Double acting style/Single rod type/Non-rotating rod Stroke (mm)							
	5	10	15	20	25	30	40	50
Bore size (mm)								
10	●	●	●	●	●	●	—	—
16	●	●	●	●	●	●	—	—
20	●	●	●	●	●	●	●	●
25	●	●	●	●	●	●	●	●
32	●	●	●	●	●	●	●	●

Mounting

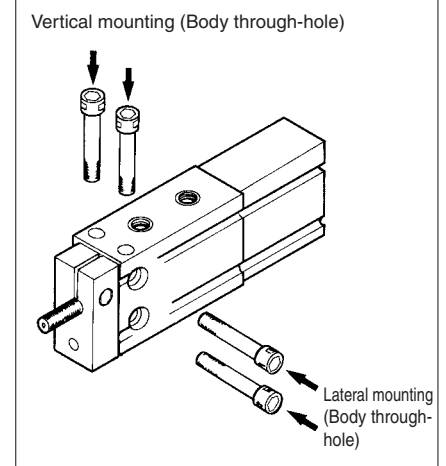

Theoretical Output/Double Acting Type

(N)

Bore size (mm)	Rod dia. (mm)	Piston area (mm ²)	Operating pressure (MPa)		
			0.3	0.5	0.7
10	4	66.0	19.8	33	46.2
16	6	172	51.6	86	121
20	8	264	79.2	132	185
25	10	412	124	206	289
32	12	691	207	346	484

Minimum Stroke for Mounting Auto Switch

Number of auto switches	Applicable auto switch		
	D-A9□, D-A9□V	D-M9□, D-M9□V	D-F9□W, D-F9□WV
1 pc.	5	5	5
2 pcs.	10	5	10

Cylinder/Applicable Pad

• In the case of rod end male thread

Use series ZPT pad (perpendicular vacuum entry/female thread mounting).

Cylinder Model	Bore size (mm)	Pad (ZPT02 to 50□□-B4 to 10)											Thread dia.
		Rod dia. (mm)											
ZCUKC	10	●	●	●	●	—	—	—	—	—	—	—	M4 x 0.7
	16	●	●	●	●	—	—	—	—	—	—	—	M5 x 0.8
ZCUKQ	20	—	—	—	—	●	●	●	●	●	—	—	M6 x 1.0
ZCDUKC	25	—	—	—	—	—	—	●	●	●	●	●	M8 x 1.25
ZCDUKQ	32	—	—	—	—	—	—	●	●	●	●	●	M10 x 1.25

• In the case of pad direct mounting

Use series ZP pad (single unit).

Cylinder Model	Bore size (mm)	Pad (ZP02 to 50□□)											
		Rod dia. (mm)											
ZCUKD ZCUKR ZCDUKD ZCDUKR	10 (Note)	●	●	●	●	—	—	—	—	—	—	—	—
	16	●	●	●	●	—	—	—	—	—	—	—	—
	20	—	—	—	—	●	●	●	—	—	—	—	—
	25	—	—	—	—	—	—	—	●	●	●	—	—
	32	—	—	—	—	—	—	—	—	—	—	●	●

Note) When using "ZC(D)UK 10", use ZP02 to 08U□-X11. Pad shape is flat only.

Auto Switch Groove

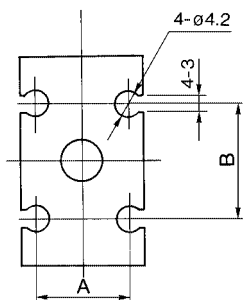

Bore size (mm)	A	B
10	10.3	13
16	15	18
20	21	23
25	27	25
32	35	27

Series ZCDUK

Proper Auto Switch Mounting Position (Detection at stroke end) and Its Mounting Height

D-A9□
D-M9□
D-F9□W

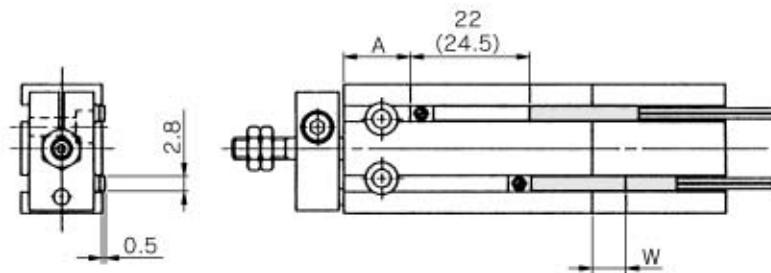

(): Denotes the values of D-A93.

D-A9□V
D-M9□V
D-F9□WV

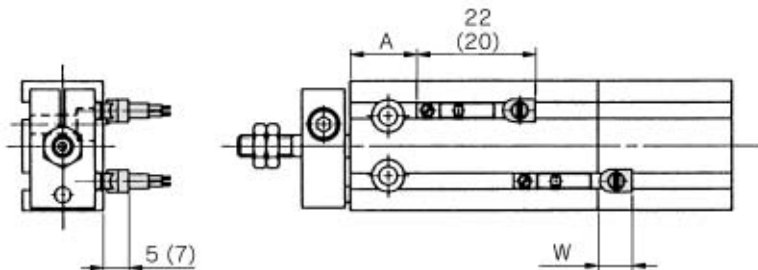

(): Denotes the values of D-M9□V, D-F9□WV.

Bore size (mm)	D-A9□, D-A9□V			D-M9□, D-F9□W			D-M9□V, D-F9□WV		
	A	B	W	A	B	W	A	B	W
10	12.5	3	-1.5 (1)	16.5	7.5	2.5	16.5	7.5	0.5
16	16	4	-2 (0.5)	20	8	1.5	20	8	0
20	20	6	-4 (-1.5)	24	10	0	24	10	-2
25	22.5	7	-5.5 (-3)	26.5	11.5	-1.5	26.5	11.5	-3.5
32	23.5	8	-6.5 (-4)	27.5	12.5	-2.5	27.5	12.5	-4.5



Note 1) Figures in the table above are used as a reference when mounting the auto switches for stroke end detection. In the case of actually setting the auto switches, adjust them after confirming their operation.

Note 2) Negative figures in the table show dimensions mounted inside cylinder body.

Note 3) In the case of 5 mm stroke or the 10 mm stroke, there are times in which the switch will not turn OFF or 2 switches will turn ON simultaneously due to their movement range. Therefore, set the position approximately 1 to 4 mm outward from the values given in the table above. Then, perform an operation inspection to make sure that the switches operate normally (if 1 switch is used, make sure that it turns ON and OFF properly; if 2 switches are used, make sure that both switches turn ON).

Note 4) Figures in () in the table W are D-A93.

Operation Range

Auto switch model	Bore size (mm)				
	10	16	20	25	32
D-A9□/A9□V	6	9	11	12.5	14
D-M9□/M9□V	2.5	3.5	5	5	5
D-F9□W/F9□WV	3.5	5.5	6.5	7	7

* Since this is the average value at a normal temperature including hysteresis (tolerance $\pm 30\%$), it is not guaranteed.

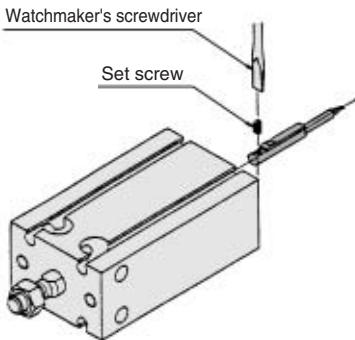
Auto Switch Specifications**Mounting of Auto Switch****Mounting**

- To tighten the auto switch mounting screws, use a watchmaker's screwdriver with a grip diameter of 5 to 6 mm.
- Tighten the screws to a torque of approximately 0.10 to 0.20 N·m.

Cautions on Proximity Installation

When free mounting cylinders equipped with auto switches are used, the auto switches could activate unintentionally if the installed distance is less than the dimensions shown in the table. Therefore, make sure to provide a greater clearance. Due to unavoidable circumstances, if they must be used with less distance than the dimensions given in the table, the cylinders must be shielded. Therefore, affix a steel plate or a magnetic shield plate (MU-S025) to the area on the cylinder that corresponds to the adjacent auto switch. (Please contact SMC for details.) Auto switches may malfunction if a shield plate is not used.

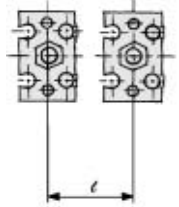

Bore size (mm)	Mounting pitch l (mm)
10	20
16	30
20	40
25	46
32	56

Weight**Basic Style/With Auto Switch**

(): Denotes the values with D-A93. (g)

Model	Bore size (mm)	Cylinder stroke (mm)							
		5	10	15	20	25	30	40	50
ZC(D)UKC	10	63 (68)	69 (79)	75 (85)	81 (91)	87 (97)	93 (103)	—	—
	16	103 (128)	115 (145)	127 (157)	139 (169)	151 (181)	163 (193)	—	—
	20	180 (214)	204 (244)	228 (267)	252 (292)	276 (316)	300 (340)	348 (388)	396 (436)
	25	304 (358)	343 (402)	382 (441)	421 (480)	460 (519)	499 (558)	577 (636)	655 (714)
	32	514 (587)	574 (652)	634 (712)	694 (772)	754 (832)	814 (892)	934 (1012)	1054 (1132)
ZC(D)UKQ	10	49 (54)	53 (63)	57 (67)	61 (71)	65 (75)	69 (79)	—	—
	16	79 (104)	86 (116)	93 (123)	100 (130)	107 (137)	114 (144)	—	—
	20	145 (179)	159 (198)	173 (212)	187 (226)	201 (240)	215 (254)	243 (282)	271 (310)
	25	259 (313)	279 (338)	299 (358)	319 (378)	339 (398)	359 (418)	399 (458)	439 (498)
	32	421 (494)	451 (529)	481 (559)	511 (589)	541 (619)	571 (649)	631 (709)	691 (769)

Series ZCUK

Construction

Cap piping/Male thread: ZC(D)UKC
 $\phi 10$

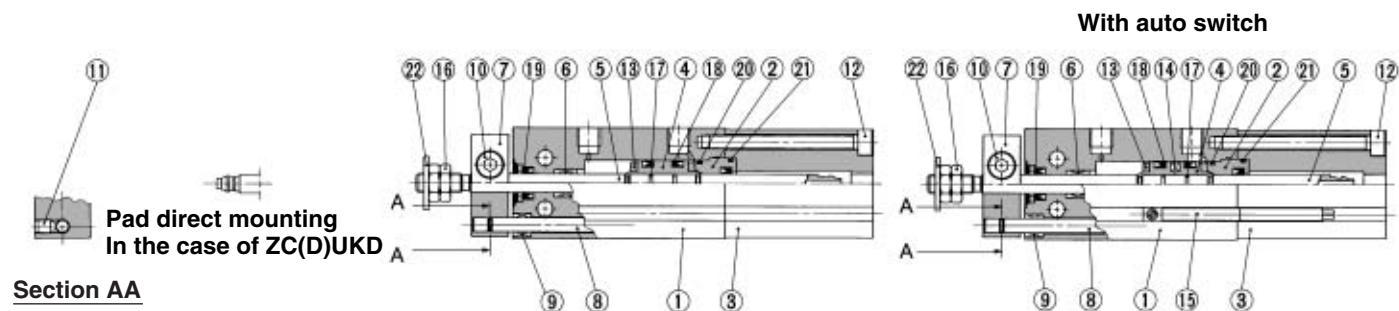

$\phi 16$ to $\phi 32$

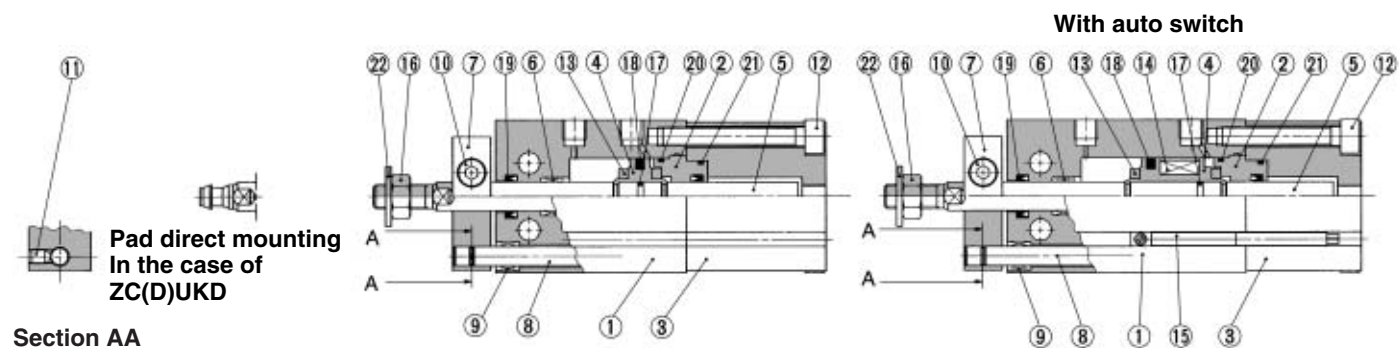

Component Parts

No.	Description	Material	Note
1	Cylinder tubing	Aluminum alloy	Hard anodized
2	Rod cover B	Aluminum bearing alloy	Chromated
3	Cap	Aluminum alloy	Hard anodized
4	Piston	Aluminum alloy	Chromated
5	Piston rod	Stainless steel	
6	Bush	Oil impregnated sintered metal	
7	Plate	Aluminum alloy	Nickel plated
8	Guide rod	Stainless steel	
9	Bush	Oil impregnated sintered metal	
10	Hexagon set screw	Carbon steel	Black zinc chromated
11	Hexagon socket head cap screw	Carbon steel	Black zinc chromated
12	Hexagon set screw	Carbon steel	Nickel plated

Component Parts

No.	Description	Material	Note
13	Damper	Urethane	
14	Magnet	Magnetic material	
15	Auto switch	—	
16	Rod end nut	Carbon steel	Nickel plated
17	Piston gasket	NBR	
18*	Piston seal	NBR	
19*	Rod seal		
20*	Gasket		
21*	Gasket for cap		
22	Seal washer	Rolled steel/NBR	

Replacement Parts: Seal Kit (Cap piping)

Kit no.	Bore size / Part no.				
	$\phi 10$	$\phi 16$	$\phi 20$	$\phi 25$	$\phi 32$
	ZCU10-PS	ZCU16-PS	ZCU20-PS	ZCU25-PS	ZCU32-PS

Seal kit consist of item 18, 19, 20, 21 contained in one kit, and can be ordered using the order number for each respective tubing bore size.

Construction

Rod piping-Male thread: ZC(D)UKQ
 $\phi 10$



Pad direct mounting
 In the case of ZC(D)UKR

Section AA

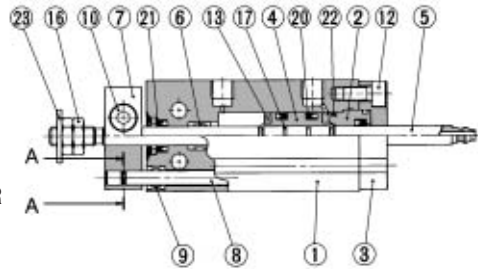

With auto switch

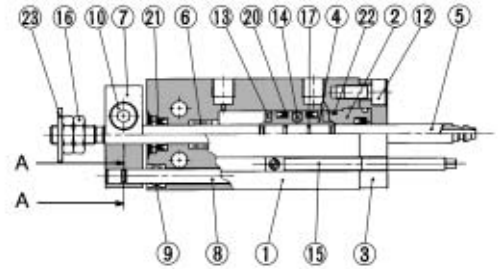

$\phi 16$ to $\phi 32$



Pad direct mounting
 In the case of ZC(D)UKR

Section AA

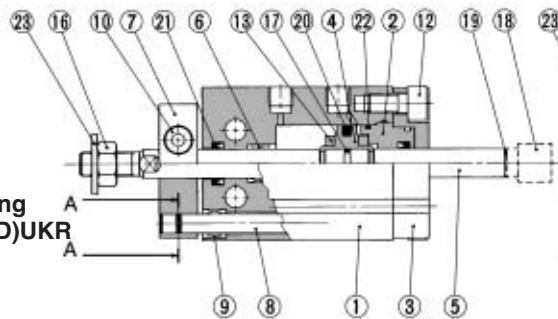

With auto switch

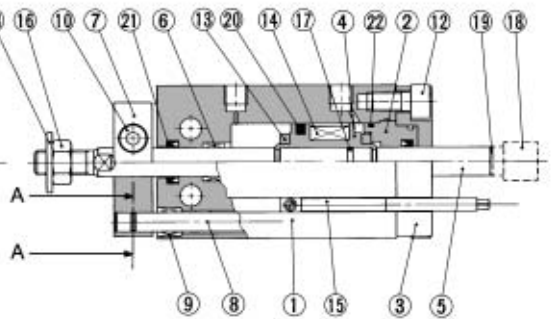

Component Parts

No.	Description	Material	Note
1	Cylinder tubing	Aluminum alloy	Hard anodized
2	Rod cover B	Aluminum bearing alloy	Chromated
3	Rod cover retainer plate	Aluminum alloy	Hard anodized
4	Piston	Aluminum alloy	Chromated
5	Piston rod	Stainless steel	
6	Bush	Oil impregnated sintered metal	
7	Plate	Aluminum alloy	Nickel plated
8	Guide rod	Stainless steel	
9	Bush	Oil impregnated sintered metal	
10	Hexagon set screw	Carbon steel	Black zinc chromated
11	Hexagon socket head cap screw	Carbon steel	Black zinc chromated
12	Hexagon set screw	Carbon steel	Nickel plated

Component Parts

No.	Description	Material	Note
13	Damper	Urethane	
14	Magnet	Magnetic material	
15	auto switch	—	
16	Rod end nut	Carbon steel	Nickel plated
17	Piston gasket	NBR	
18	Socket	Carbon steel	$\phi 16$ only
19	Gasket		$\phi 16$ only
20	Piston seal	NBR	
21*	Rod seal		
22*	Gasket		
23*	Seal washer	Rolled steel/NBR	

Replacement Parts: Seal Kit (Rod piping)

Kit no.	Bore size / Part no.				
	$\phi 10$	$\phi 16$	$\phi 20$	$\phi 25$	$\phi 32$
	CUW10-PS	CUW16-PS	CUW20-PS	CUW25-PS	CUW32-PS

Seal kit consist of item 20, 21, 22 contained in one kit, and can be ordered using the order number for each respective tubing bore size.

Series ZCUK

Vacuum Piping: Cap Piping/Rod End Shape: Male Thread

ZC(D)UKC —

ø10

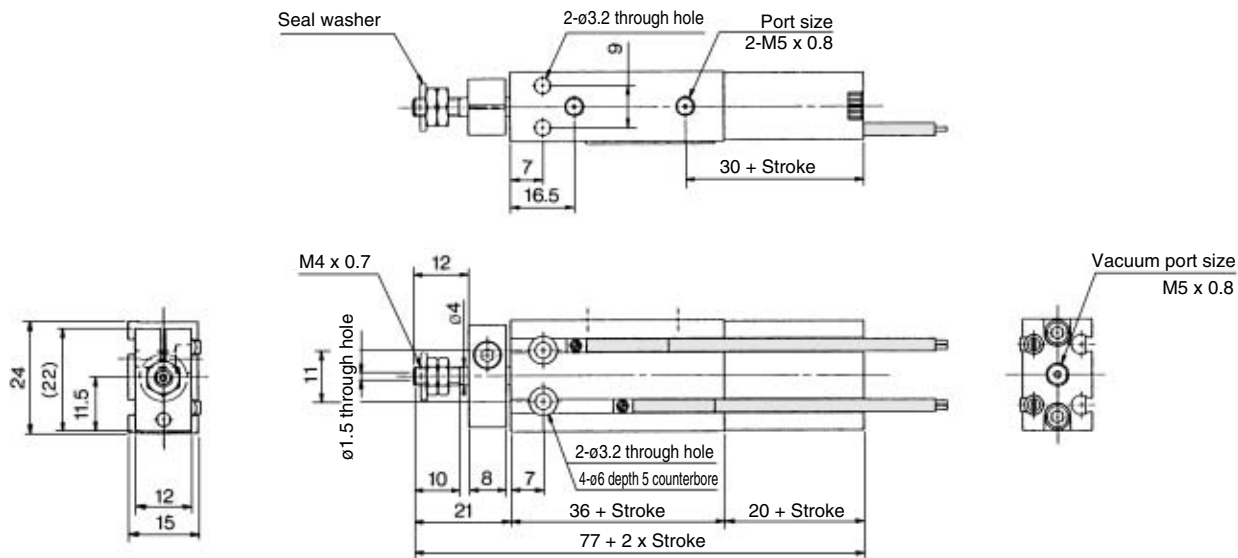

ø16 to ø32

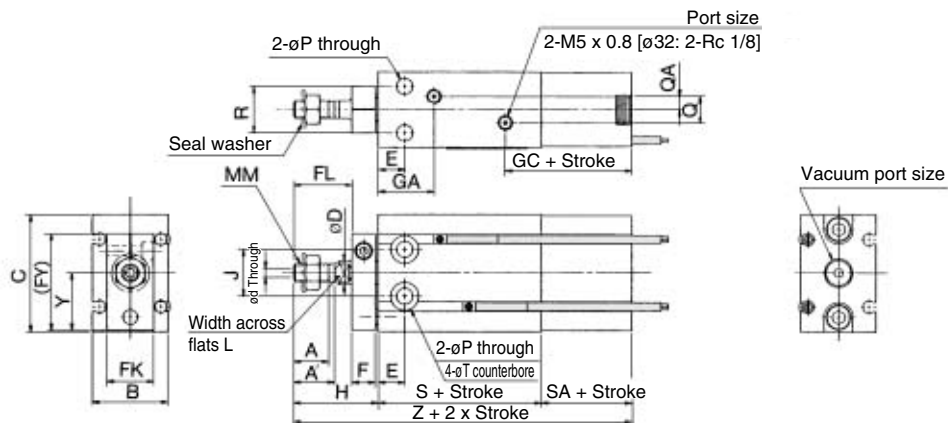

Model	Port size		Stroke range (mm)	A	A'	B	C	ød	øD	E	F	FK	FL	FY	GA	GC
	Air port	Vacuum port														
ZC(D)UKC16	M5 x 0.8	M5 x 0.8	5 to 30	11	12.5	20	32	2	6	7	8	13	17	28	16.5 ^{Note)}	31
ZC(D)UKC20	M5 x 0.8	Rc 1/8	5 to 50	12	14	26	40	3	8	9	8	16	20	33	19	33.5
ZC(D)UKC25	M5 x 0.8	Rc 1/8	5 to 50	15.5	18	32	50	4	10	10	10	20	22	43.5	21.5	34
ZC(D)UKC32	Rc 1/8	Rc 1/8	5 to 50	19.5	22	40	62	5	12	11	12	24	29	51.5	23	34.5

Model	H	J	L	MM	øP	Q	QA	R	S	SA	øT	Y	Z
ZC(D)UKC16	26	14	5	M5 x 0.8	4.5	4	2	12	30 (40)	19.5	7.6 depth 6.5	15.5	75.5 (85.5)
ZC(D)UKC20	29	16	6	M6 x 1.0	5.5	9	4.5	16	36 (46)	21	9.3 depth 9	19.5	86 (96)
ZC(D)UKC25	33	20	8	M8 x 1.25	5.5	9	4.5	20	40 (50)	21	9.3 depth 8	24.5	94 (104)
ZC(D)UKC32	42	24	10	M10 x 1.25	6.6	13.5	4.5	24	42 (52)	22	11 depth 11.5	30.5	106 (116)

(): In the case of a mounted auto switch.

Note) In the case of ZCUK16-5D: 14.5 mm.

Vacuum Piping: Cap Piping/Rod End Shape: Pad Direct MountingZC(D)UKD Cylinder bore — Stroke D

ø10

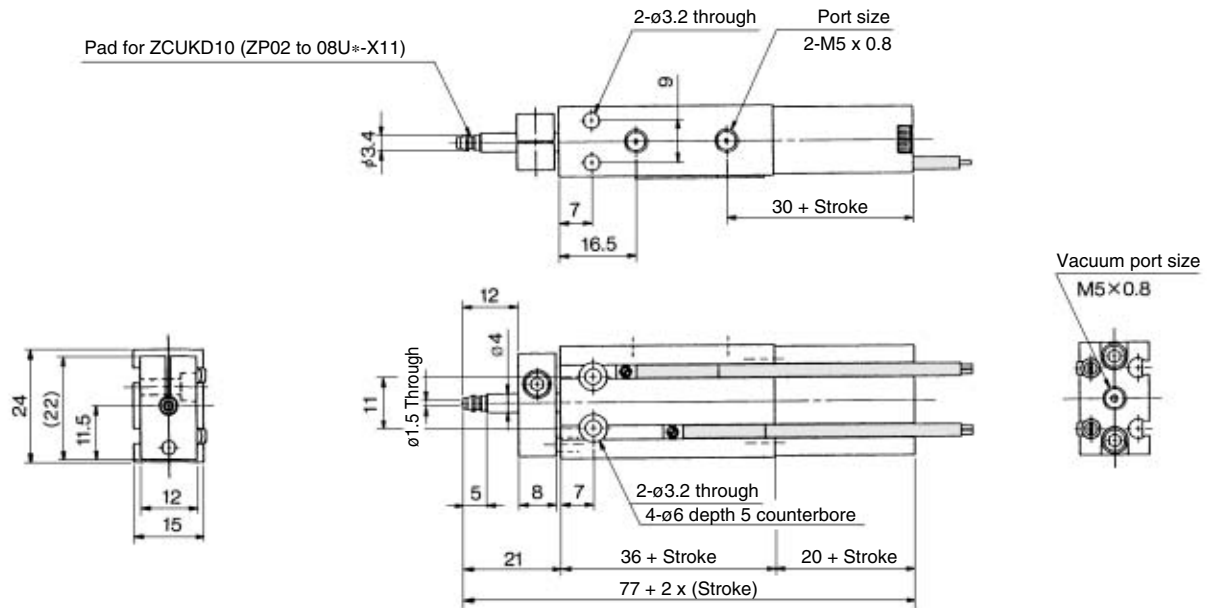

ø16 to ø32

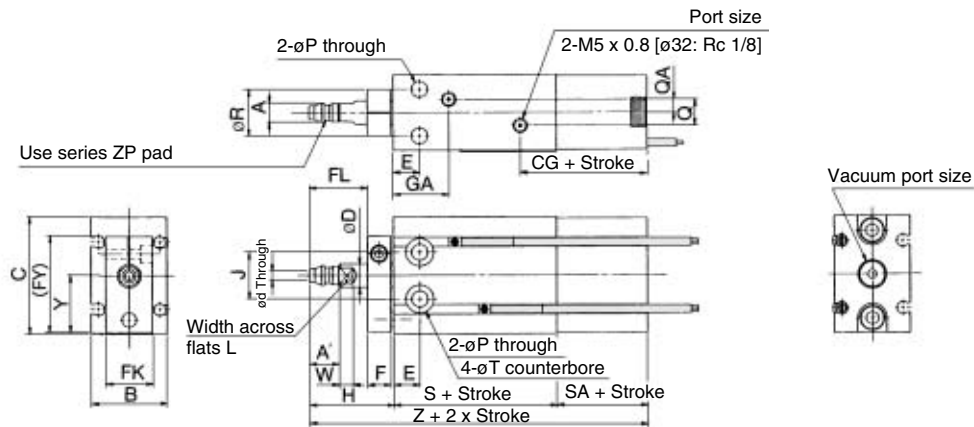

Model	Port size		Stroke range (mm)	øA	A'	B	C	ød	øD	E	F	FK	FL	FY	GA	GC
	Air port	Vacuum port														
ZC(D)UKD16	M5 x 0.8	M5 x 0.8	5 to 30	5	7	20	32	2	6	7	8	13	17	28	16.5 ^{Note)}	31
ZC(D)UKD20	M5 x 0.8	Rc 1/8	5 to 50	6.6	8	26	40	3	8	9	8	16	20	33	19	33.5
ZC(D)UKD25	M5 x 0.8	Rc 1/8	5 to 50	8	9	32	50	4	10	10	10	20	22	43.5	21.5	34
ZC(D)UKD32	Rc 1/8	Rc 1/8	5 to 50	11.5	10.5	40	62	5	12	11	12	24	29	51.5	23	34.5

Model	H	J	L	øP	Q	QA	R	S	SA	øT	W	Y	Z
ZC(D)UKD16	26	14	5	4.5	4	2	12	30 (40)	19.5	7.6 depth 6.5	3.5	15.5	75.5 (85.5)
ZC(D)UKD20	29	16	6	5.5	9	4.5	16	36 (46)	21	9.3 depth 8	5	19.5	86 (96)
ZC(D)UKD25	33	20	8	5.5	9	4.5	20	40 (50)	21	9.3 depth 9	5	24.5	94 (104)
ZC(D)UKD32	42	24	10	6.6	13.5	4.5	24	42 (52)	22	11 depth 11.5	5	30.5	106 (116)

(): In the case of a mounted auto switch.

Note) In the case of ZCUKD16-5D: 14.5 mm.

Series ZCUK

Vacuum Piping: Rod Piping/Rod End Shape: Male Thread

ZC(D)UKQ Cylinder bore Stroke D

ø10

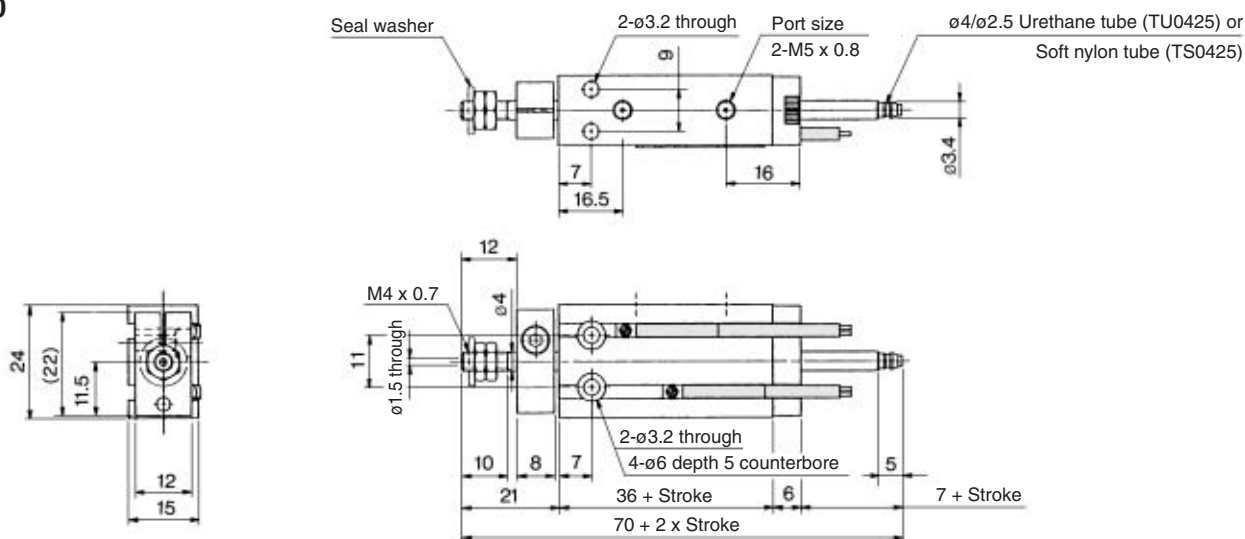

ø16 to ø32

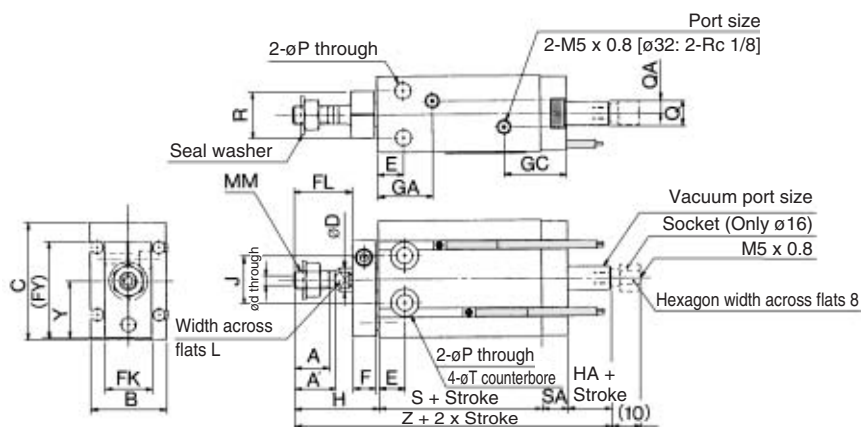

Model	Port size		Stroke range (mm)	A	A'	B	C	ød	øD	E	F	FK	FL	FY	GA	GC
	Air port	Vacuum port														
ZC(D)UKQ16	M5 x 0.8	M5 x 0.8 ⁽²⁾	5 to 30	11	12.5	20	32	2	6	7	8	13	17	28	16.5 ⁽¹⁾	19
ZC(D)UKQ20	M5 x 0.8	M5 x 0.8	5 to 50	12	14	26	40	3	8	9	8	16	20	33	19	21.5
ZC(D)UKQ25	M5 x 0.8	M5 x 0.8	5 to 50	15.5	18	32	50	4	10	10	10	20	22	43.5	21.5	22
ZC(D)UKQ32	Rc 1/8	Rc 1/8	5 to 50	19.5	22	40	62	5	12	11	12	24	29	51.5	23	22.5

Model	H	HA	J	L	MM	øP	Q	QA	R	S	SA	øT	Y	Z
ZC(D)UKQ16	26	5	14	5	M5 x 0.8	4.5	4	2	12	30 (40)	7.5	7.6 depth 6.5	15.5	68.5 (78.5)
ZC(D)UKQ20	29	5	16	6	M6 x 1.0	5.5	9	4.5	16	36 (46)	9	9.3 depth 8	19.5	79 (89)
ZC(D)UKQ25	33	5	20	8	M8 x 1.25	5.5	9	4.5	20	40 (50)	9	9.3 depth 9	24.5	87 (97)
ZC(D)UKQ32	42	5	24	10	M10 x 1.25	6.6	13.5	4.5	24	42 (52)	10	11 depth 11.5	30.5	99 (109)

(): In the case of a mounted auto switch.

Note 1) In the case of ZCUKR16-5D: 14.5 mm.

Note 2) In the case of socket equipped type.

Free Mount Cylinder for Vacuum **Series ZCUK**

Vacuum Piping: Rod Piping/Rod End Shape: Pad Direct Mounting

ZC(D)UKR Cylinder bore — Stroke D

ø10

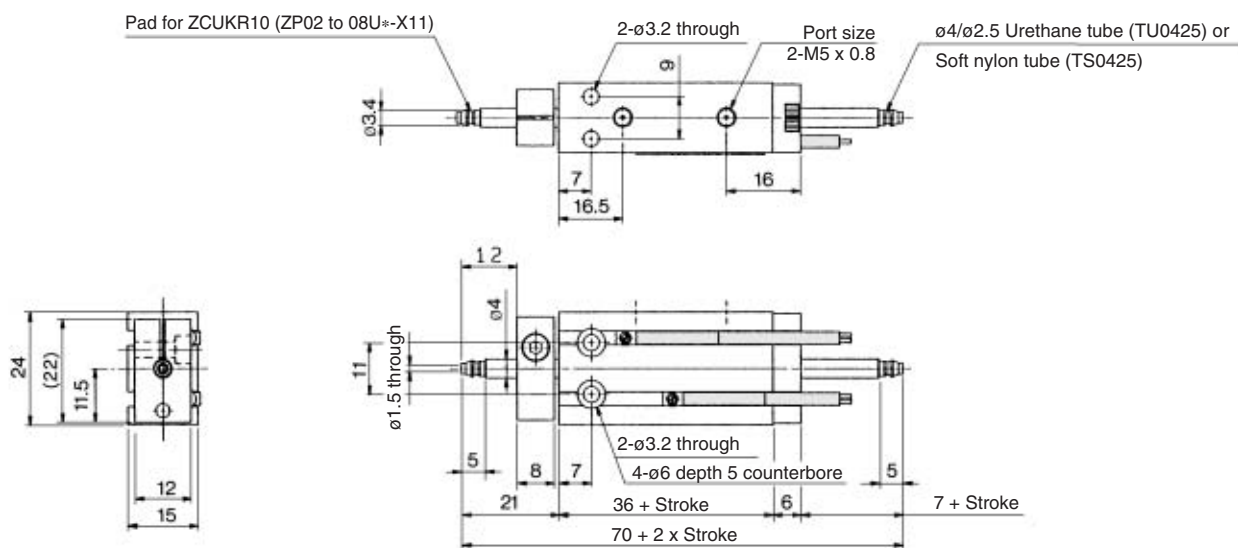

ø16 to ø32

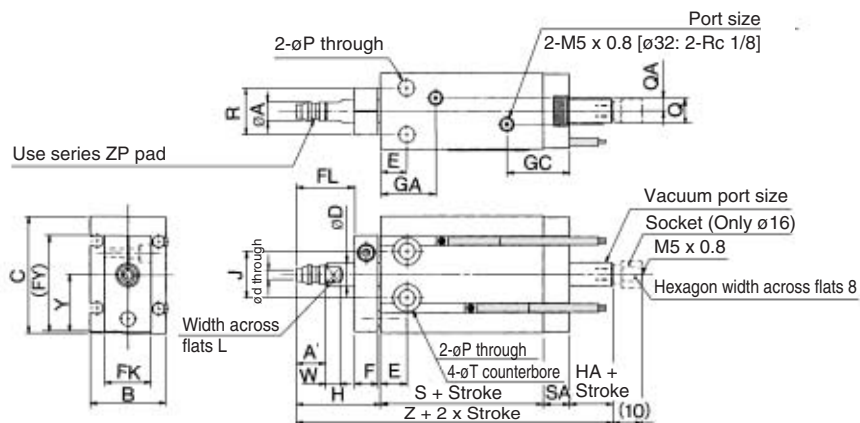

Model	Port size		Stroke range (mm)	øA	A	B	C	ød	øD	E	F	FK	FL	FY	GA	GC
	Air port	Vacuum port														
ZC(D)UKR16	M5 x 0.8	M5 x 0.8 ⁽²⁾	5 to 30	5	7	20	32	2	6	7	8	13	17	28	16.5 ⁽¹⁾	19
ZC(D)UKR20	M5 x 0.8	M5 x 0.8	5 to 50	6.6	8	26	40	3	8	9	8	16	20	33	19	21.5
ZC(D)UKR25	M5 x 0.8	M5 x 0.8	5 to 50	8	9	32	50	4	10	10	10	20	22	43.5	21.5	22
ZC(D)UKR32	Rc 1/8	Rc 1/8	5 to 50	11.5	10.5	40	62	5	12	11	12	24	29	51.5	23	22.5

Model	H	HA	J	L	øP	Q	QA	R	S	SA	øT	W	Y	Z
ZC(D)UKR16	26	5	14	5	4.5	4	2	12	30 (40)	7.5	7.6 depth 6.5	3.5	15.5	68.5 (78.5)
ZC(D)UKR20	29	5	16	6	5.5	9	4.5	16	36 (46)	9	9.3 depth 8	5	19.5	79 (89)
ZC(D)UKR25	33	5	20	8	5.5	9	4.5	20	40 (50)	9	9.3 depth 9	5	24.5	87 (97)
ZC(D)UKR32	42	5	24	10	6.6	13.5	4.5	24	42 (52)	10	11 depth 11.5	5	30.5	99 (109)

(): In the case of a mounted auto switch.

Note 1) In the case of ZCUKQ16-5D: 14.5 mm.

Note 2) In the case of socket equipped type.

Series CU

Auto Switch Specifications

Auto Switch Common Specifications

Type	Reed switch	Solid state switch
Leakage current	None	3-wire: 100 μ A or less 2-wire: 0.8 mA or less
Operating time	1.2 ms	1 ms or less
Impact resistance	300 m/s ²	1000 m/s ²
Insulation resistance	50 M Ω or more at 500 VDC Mega (between lead wire and case)	
Withstand voltage	1000 VAC for 1 minute (between lead wire and case)	
Ambient temperature	-10 to 60°C	
Enclosure	IEC529 standard IP67, JIS C 0920 watertight construction	

Lead Wire Length

Lead wire length indication

(Example) D-M9P **L**

Lead wire length

Nil	0.5 m
L	3 m
Z	5 m

Note 1) Applicable auto switch with 5 m lead wire "Z"

Solid state switch: Manufactured upon receipt of order as standard.

Note 2) To designate solid state switches with flexible specifications, add "-61" after the lead wire length.

* Oilproof flexible heavy-duty cord is used for D-M9□ as standard. There is no need to suffix -61 to the end of part number.

(Example) D-F9PWVL- **61**

Flexible specification

Auto Switch Hysteresis

The hysteresis is the difference between the position of the auto switch as it turns "on" and as it turns "off". A part of operating range (one side) includes this hysteresis.

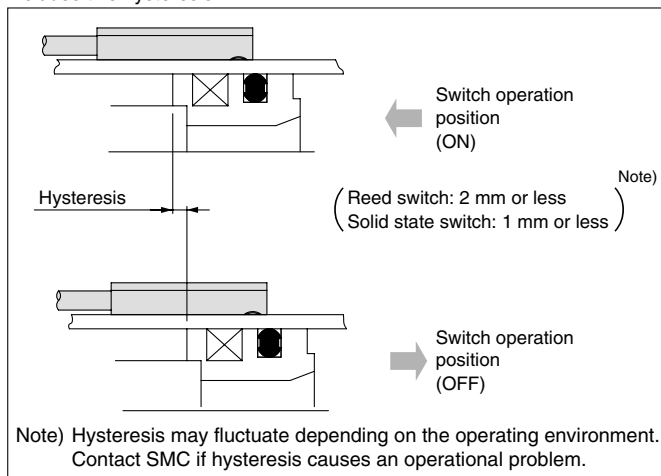

Contact Protection Box: CD-P11, CD-P12

<Applicable switch model>

D-A9•A9□V

The auto switches above do not have a built-in contact protection circuit. Therefore, please use a contact protection box with the switch for any of the following cases:

- ① Where the operation load is an inductive load.
- ② Where the wiring length to load is greater than 5 m.
- ③ Where the load voltage is 100 VAC.

The contact life may be shortened. (Due to permanent energizing conditions.)

Specifications

Part No.	CD-P11		CD-P12
Load voltage	100 VAC	200 VAC	24 VDC
Maximum load current	25 mA	12.5 mA	50 mA

* Lead wire length — Switch connection side 0.5 m
Load connection side 0.5 m



Internal Circuit

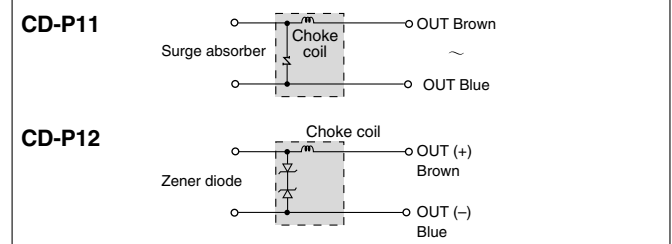

Dimension

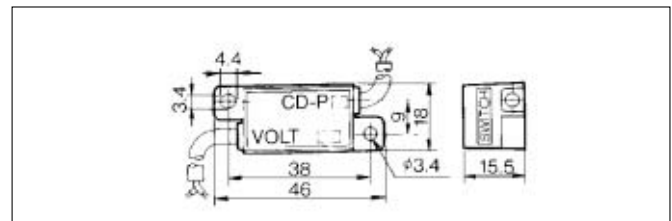

Connection

To connect a switch unit to a contact protection box, connect the lead wire from the side of the contact protection box marked SWITCH to the lead wire coming out of the switch unit. Keep the switch as close as possible to the contact protection box, with a lead wire length of no more than 1 meter.

Series CU

Auto Switch Connections and Examples

Basic Wiring

Solid state 3-wire, NPN

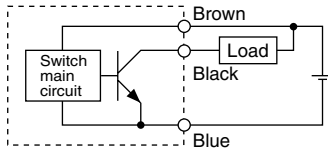

Solid state 3-wire, PNP

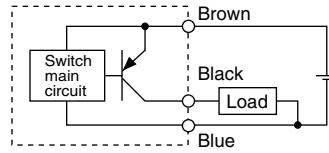

2-wire (Solid state switch)

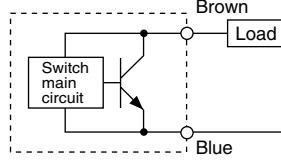

2-wire (Reed switch)

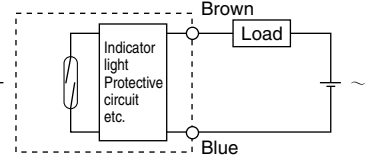

(Power supplies for switch and load are separate.)

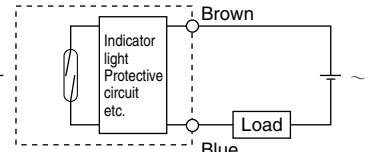
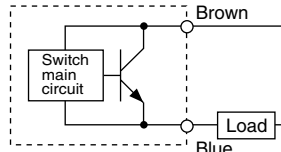
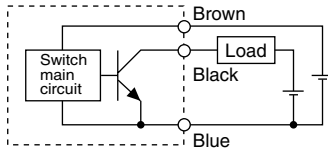

Examples of Connection to PLC (Programmable Logic Controller)

• Sink input specifications 3-wire, NPN

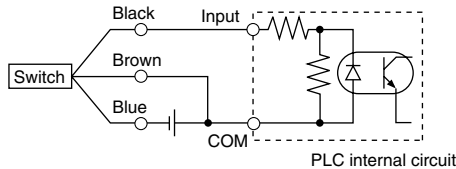

• Source input specifications 3-wire, PNP

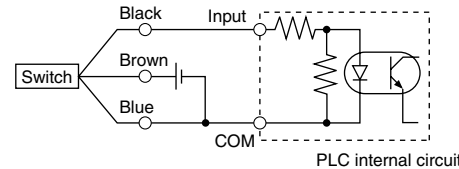

Connect according to the applicable PLC input specifications, as the connection method will vary depending on the PLC input specifications.

2-wire

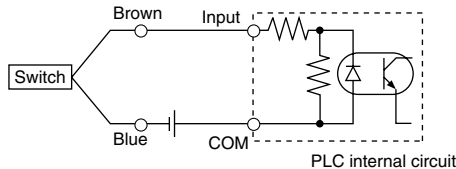

2-wire

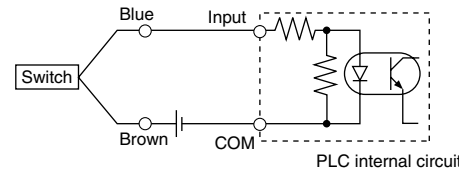

Connection Examples for AND (Serial) and OR (Parallel)

• 3-wire

AND connection for NPN output (using relays)

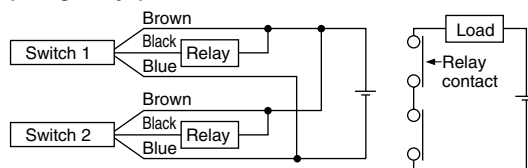

AND connection for NPN output (performed with switches only)

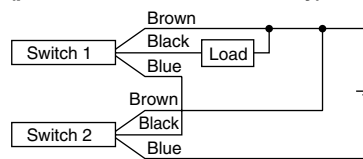

OR connection for NPN output

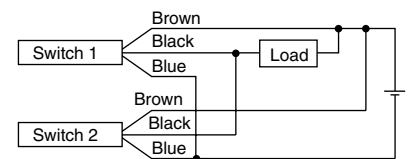

The indicator lights will light up when both switches are turned ON.

2-wire with 2-switch AND connection

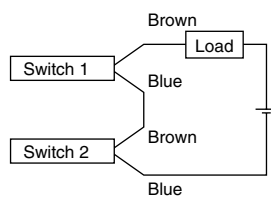

When two switches are connected in series, a load may malfunction because the load voltage will decline when in the ON state. The indicator lights will light up if both of the switches are in the ON state.

$$\begin{aligned} \text{Load voltage at ON} &= \text{Power supply voltage} - \text{Internal voltage drop} \times 2 \text{ pcs.} \\ &= 24 \text{ V} - 4 \text{ V} \times 2 \text{ pcs.} \\ &= 16 \text{ V} \end{aligned}$$

Example: Power supply is 24 VDC.
Internal voltage drop in switch is 4 V.

2-wire with 2-switch OR connection

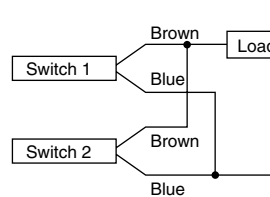

(Solid state switch)

When two switches are connected in parallel, a malfunction may occur because the load voltage will increase when in the OFF state.

(Reed switch)

Because there is no current leakage, the load voltage will not increase when turned OFF. However, depending on the number of switches in the ON state, the indicator lights may sometimes dim or not light because of the dispersion and reduction of the current flowing to the switches.

$$\begin{aligned} \text{Load voltage at OFF} &= \text{Leakage current} \times 2 \text{ pcs.} \times \text{Load impedance} \\ &= 1 \text{ mA} \times 2 \text{ pcs.} \times 3 \text{ k}\Omega \\ &= 6 \text{ V} \end{aligned}$$

Example: Load impedance is 3 kΩ.
Leakage current from switch is 1 mA.

Reed Switch: Direct Mounting Style

D-A90(V)/D-A93(V)/D-A96(V) C €

Grommet Electrical entry : In-line



⚠ Caution

Operating Precautions

Fix the switch with the existing screw installed on the switch body. The switch may be damaged if a screw other than the one supplied, is used.

Auto Switch Internal Circuit

D-A90(V)

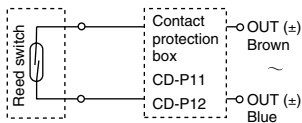

D-A93(V)

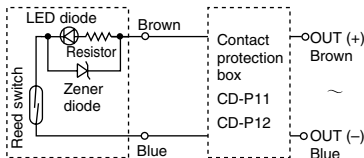

D-A96(V)

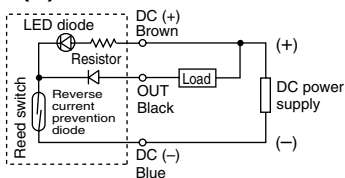

- Note) ① In a case where the operation load is an inductive load.
 ② In a case where the wiring load is greater than 5 m.
 ③ In a case where the load voltage is 100 VAC.

Please use the auto switch with a contact protection box any of the above mentioned cases. (For details about the contact protection box, refer to page 68.)

Auto Switch Specifications



For details about certified products conforming to international standards, visit us at www.smcworld.com.

PLC: Abbreviation for Programmable Logic Controller

D-A90/D-A90V (without indicator light)			
Auto switch part no.	D-A90/D-A90V		
Applicable load	IC circuit, Relay, PLC		
Load voltage	24 V AC/DC or less	48 V AC/DC or less	100 V AC/DC or less
Maximum load current	50 mA	40 mA	20 mA
Contact protection circuit	None		
Internal resistance	1 Ω or less (including lead wire length of 3 m)		
D-A93/D-A93V/D-A96/D-A96V (with indicator light)			
Auto switch part no.	D-A93/D-A93V		D-A96/D-A96V
Applicable load	Relay, PLC		IC circuit
Load voltage	24 VDC	100 VAC	4 to 8 VDC
Load current range and max. load current	5 to 40 mA	5 to 20 mA	20 mA
Contact protection circuit	None		
Internal voltage drop	D-A93 — 2.4 V or less (to 20 mA)/3 V or less (to 40 mA) D-A93V — 2.7 V or less		0.8 V or less
Indicator light	Red LED lights when ON		

● Lead wires

D-A90(V)/D-A93(V) — Oilproof vinyl heavy-duty cord: $\phi 2.7$, 0.18 mm² x 2 cores (Brown, Blue), 0.5 m
 D-A96(V) — Oilproof vinyl heavy-duty cord: $\phi 2.7$, 0.15 mm² x 3 cores (Brown, Black, Blue), 0.5 m

Note 1) Refer to page 68 for reed switch common specifications.

Note 2) Refer to page 68 for lead wire lengths.

Note 3) Under 5 mA, the strength of the indicator light is poor. In some cases, visibility of the indicator light will not be possible where the output signal is less than 2.5 mA. However, there is no problem in terms of contact output, when an output signal exceeds 1 mA or more.

Weight

Unit: g

Auto switch model	D-A90	D-A90V	D-A93	D-A93V	D-A96	D-A96V
Lead wire length: 0.5 m	6	6	6	6	8	8
Lead wire length: 3 m	30	30	30	30	41	41

Dimensions

Unit: mm

D-A90/D-A93/D-A96

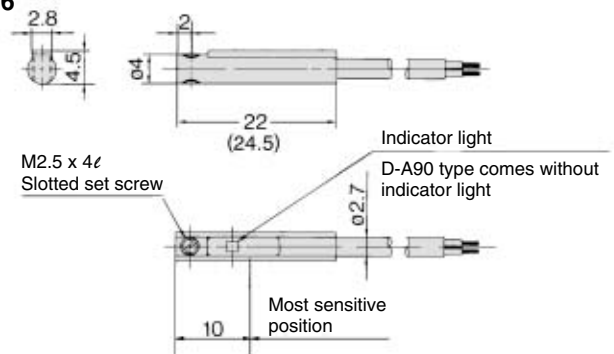

(): dimensions for D-A93.

D-A90V/D-A93V/D-A96V

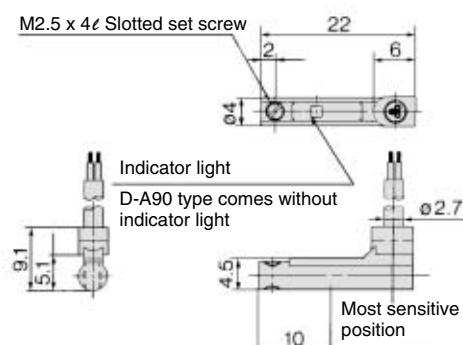

Solid State Switch: Direct Mounting Style

D-M9N(V)/D-M9P(V)/D-M9B(V) C €

Grommet

- 2-wire load current is reduced (2.5 to 40 mA)
- Lead-free
- UL certified (style 2844) lead cable is used.



⚠ Caution

Operating Precautions

Fix the switch with the existing screw installed on the switch body. The switch may be damaged if a screw other than the one supplied, is used.

Auto Switch Internal Circuit

D-M9N(V)

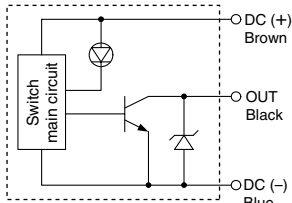

D-M9P(V)

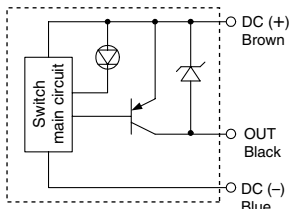

D-M9B(V)

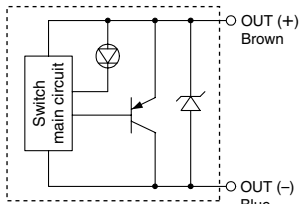

Auto Switch Specifications



For details about certified products conforming to international standards, visit us at www.smcworld.com.

PLC: Abbreviation of Programmable Logic Controller

D-M9□, D-M9□V (With indicator light)						
Auto switch part no.	D-M9N	D-M9NV	D-M9P	D-M9PV	D-M9B	D-M9BV
Electrical entry direction	In-line	Perpendicular	In-line	Perpendicular	In-line	Perpendicular
Wiring type	3-wire			2-wire		
Output type	NPN		PNP		—	
Applicable load	IC circuit, Relay, PLC				24 VDC relay, PLC	
Power supply voltage	5, 12, 24 VDC (4.5 to 28 V)				—	
Current consumption	10 mA or less				—	
Load voltage	28 VDC or less		—		24 VDC (10 to 28 VDC)	
Load current	40 mA or less				2.5 to 40 mA	
Internal voltage drop	0.8 V or less				4 V or less	
Leakage current	100 μA or less at 24 VDC				0.8 mA or less	
Indicator light	Red LED lights when ON.					

● Lead wires

Oilproof vinyl heavy-duty cord: $\phi 2.7 \times 3.2$ ellipse, 0.15 mm²,

D-M9B(V) 0.15 mm² x 2 cores

D-M9N(V), D-M9P(V) 0.15 mm² x 3 cores

Note 1) Refer to page 68 for solid state switch common specifications.

Note 2) Refer to page 68 for lead wire lengths.

Weight

Unit: g

Auto switch model	D-M9N(V)	D-M9P(V)	D-M9B(V)
Lead wire length (m)	0.5	8	7
	3	41	38
	5	68	63

Dimensions

Unit: mm

D-M9□

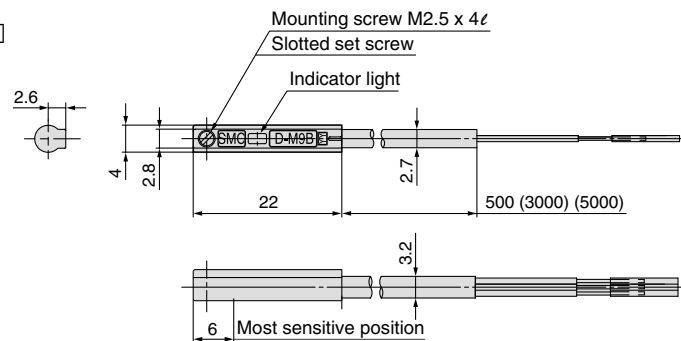

D-M9□V

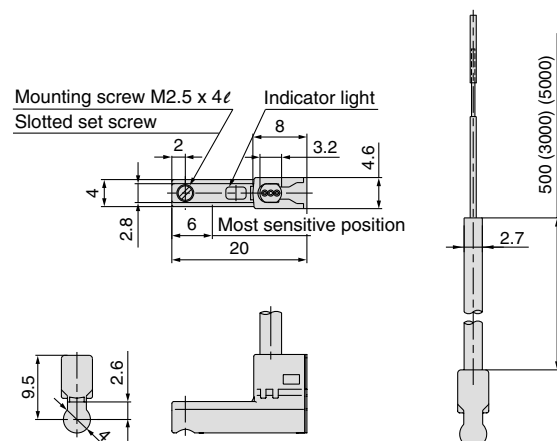

2-color Indication, Solid State Switch: Direct Mounting Style D-F9NW(V)/D-F9PW(V)/D-F9BW(V)

 For details about certified products conforming to international standards, visit us at www.smcworld.com.

Auto Switch Specifications

PLC: Abbreviation for Programmable Logic Controller

D-F9□W/D-F9□WV (with indicator light)						
Auto switch part no.	D-F9NW	D-F9NWV	D-F9PW	D-F9PWV	D-F9BW	D-F9BWV
Electrical entry direction	In-line	Perpendicular	In-line	Perpendicular	In-line	Perpendicular
Wiring type	3-wire				2-wire	
Output type	NPN		PNP		—	
Applicable load	IC circuit, Relay, PLC				24 VDC relay, PLC	
Power supply voltage	5, 12, 24 VDC (4.5 to 28 VDC)				—	
Current consumption	10 mA or less				—	
Load voltage	28 VDC or less		—		24 VDC (10 to 28 VDC)	
Load current	40 mA or less		80 mA or less		5 to 40 mA	
Internal voltage drop	1.5 V or less (0.8 V or less at 10 mA load current)		0.8 V or less		4 V or less	
Leakage current	100 μA or less at 24 VDC				0.8 mA or less	
Indicator light	Operating position Red LED lights up Optimum operating position Green LED lights up					

Grommet



⚠ Caution

Operating Precautions

Fix the switch with the existing screw installed on the switch body. The switch may be damaged if a screw other than the one supplied, is used.

Auto Switch Internal Circuit

D-F9NW(V)

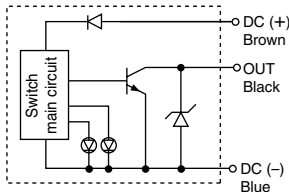

D-F9PW(V)

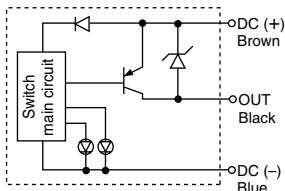

D-F9BW(V)

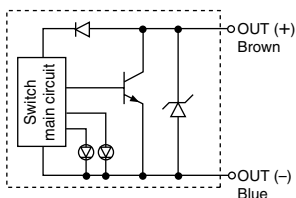

Indicator light/Display method

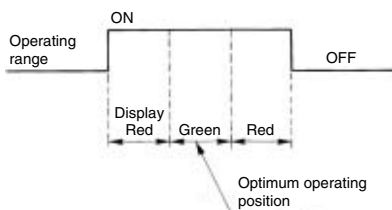

- Lead wires
Oilproof vinyl heavy-duty cord: $\phi 2.7$, 0.15 mm² x 3 cores (Brown, Black, Blue), 0.18 mm² x 2 cores (Brown, Blue), 0.5 mm
- Note 1) Refer to page 68 for solid state switch common specifications.
- Note 2) Refer to page 68 for lead wire lengths.

Weight

Unit: g

Auto switch model	D-F9NW(V)	D-F9PW(V)	D-F9BW(V)
Lead wire length (m)	0.5	7	7
	3	34	32
	5	56	52

Dimensions

Unit: mm

D-F9□W

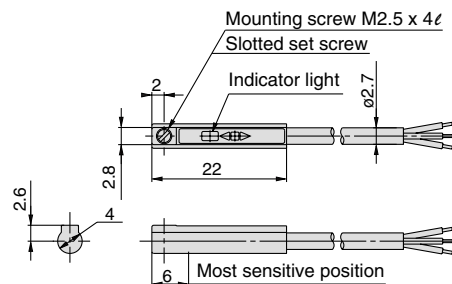

D-F9□WV

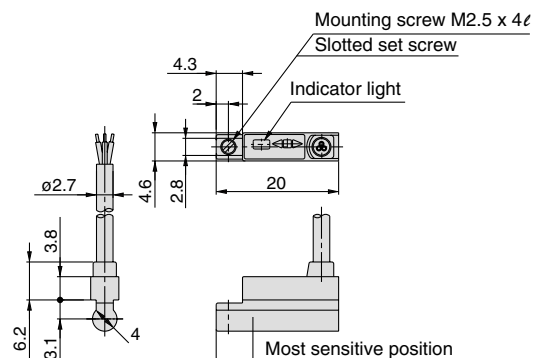



Series CU

Safety Instructions

The following safety instructions are intended to prevent a hazardous situation and/or equipment damage. The instructions indicate the level of potential hazard by labels of "Caution", "Warning" or "Danger". To ensure safety, please observe all safety practices, including ISO 4414 ^{Note 1)} and JIS B 8370 ^{Note 2)}.

⚠ Caution : Operator error could result in injury or equipment damage.

⚠ Warning : Operator error could result in serious injury or loss of life.

⚠ Danger : In extreme conditions, there is a possible result of serious injury or loss of life.

Note 1) ISO 4414: Pneumatic fluid power--General rules relating to systems.

Note 2) JIS B 8370: General Rules for Pneumatic Equipment

⚠ Warning

1. The compatibility of pneumatic equipment is the responsibility of the person who designs the pneumatic system or decides its specifications.

Since the products specified here are used in various operating conditions, their compatibility with a specific pneumatic system must be based on specifications, post analysis and/or tests to meet a specific requirement. The expected performance and safety assurance is the responsibility of the person who determines the compatibility of the system. This person should continuously review the suitability of all specified items by referring to the latest information in the catalog and by taking into consideration the possibility of equipment failure when configuring the system.

2. Only trained personnel should operate pneumatically operated machinery and equipment.

Compressed air can be dangerous if an operator is unfamiliar with it. Assembly, handling or repair of pneumatic systems should be performed by trained and experienced operators.

3. Do not service machinery/equipment or attempt to remove components until safety is confirmed.

1. Inspection and maintenance of machinery/equipment should only be performed once measures to prevent falling or runaway of the driver objects have been confirmed.
2. When equipment is to be removed, confirm the all safety precautions have been followed. Cut the supply pressure for this equipment and exhaust all residual compressed air in the system.
3. Before restarting any machinery/equipment, exercise caution to prevent quick extension of a cylinder piston rod, etc.

4. Contact SMC if the product is to be used in any of the following conditions:

1. Conditions and environments beyond the given specifications, or if product is used outdoors.
2. Installation on equipment in conjunction with atomic energy, railway, air navigation, vehicles, medical equipment, food and beverages, recreation equipment, emergency stop circuits, clutch and brake circuits in press applications, or safety equipment.
3. An application which has the possibility of having a negative effect on people, property, or animals, requiring special safety analysis.



Series CU Actuator Precautions 1

Be sure to read before handling.

Caution on Design

⚠ Warning

- 1. There is a possibility of dangerous sudden action by air cylinders if sliding parts of machinery are twisted due to external forces, etc.**

In such cases, human injury may occur; e.g., by catching hands or feet in the machinery, or damage to the machinery itself may occur. Therefore, the machine should be adjusted to operate smoothly and designed to avoid such dangers.

- 2. A protective cover is recommended to minimize the risk of personal injury.**

If a stationary object and moving parts of a cylinder are in close proximity, personal injury may occur. Design the structure to avoid contact with the human body.

- 3. Securely tighten all stationary parts and connected parts so that they will not become loose.**

Especially when a cylinder operates with high frequency or is installed where there is a lot of vibration, ensure that all parts remain secure.

- 4. A deceleration circuit or shock absorber may be required.**

When a driven object is operated at high speed or the load is heavy, a cylinder's cushion will not be sufficient to absorb the impact. Install a deceleration circuit to reduce the speed before cushioning, or install an external shock absorber to relieve the impact. In this case, the rigidity of the machinery should also be examined.

- 5. Consider a possible drop in circuit pressure due to a power outage, etc.**

When a cylinder is used in a clamping mechanism, there is a danger of workpieces dropping if there is a decrease in clamping force due to a drop in circuit pressure caused by a power outage, etc. Therefore, safety equipment should be installed to prevent damage to machinery and human injury. Suspension mechanisms and lifting devices also require consideration for drop prevention.

- 6. Consider a possible loss of power source.**

Measures should be taken to protect against bodily injury and equipment damage in the event that there is a loss of power to equipment controlled by pneumatics, electricity, or hydraulics.

- 7. Design circuitry to prevent sudden lurching of driven objects.**

When a cylinder is driven by an exhaust center type directional control valve or when starting up after residual pressure is exhausted from the circuit, etc., the piston and its driven object will lurch at high speed if pressure is applied to one side of the cylinder because of the absence of air pressure inside the cylinder. Therefore, equipment should be selected and circuits designed to prevent sudden lurching, because there is a danger of human injury and/or damage to equipment when this occurs.

- 8. Consider emergency stops.**

Design so that human injury and/or damage to machinery and equipment will not be caused when machinery is stopped by a safety device under abnormal conditions, a power outage or a manual emergency stop.

- 9. Consider the action when operation is restarted after an emergency stop or abnormal stop.**

Design the machinery so that human injury or equipment damage will not occur upon restart of operation.

When the cylinder has to be reset at the starting position, install manual safety equipment.

Selection

⚠ Warning

- 1. Confirm the specifications.**

The products featured in this catalog are designed for use in industrial compressed air systems. If the products are used in conditions where pressure and/or temperature are outside the range of specifications, damage and/or malfunctions may occur. Do not use in these conditions. (Refer to the specifications.)

Consult with SMC if you use a fluid other than compressed air.

⚠ Caution

- 1. Operate within the limits of the maximum usable stroke.**

The piston rod will be damaged if operated beyond the maximum stroke. Refer to the air cylinder's model selection procedure for the maximum stroke availability.

- 2. Operate the piston within a range such that collision damage will not occur at the stroke end.**

Operate within a range such that damage will not occur when the piston, having inertial force, stops by striking the cover at the stroke end. Refer to the cylinder model selection procedure for the range within which damage will not occur.

- 3. Use a speed controller to adjust the cylinder drive speed, gradually increasing from a low speed to the desired speed setting.**

Mounting

⚠ Caution

- 1. Be certain to match the rod shaft center with the direction of the load and movement when connecting.**

When not properly matched, problems may arise with the rod and tube, and damage may be caused due to friction on areas such as the inner tube surface, bushings, rod surface and seals.

- 2. When an external guide is used, connect the rod end and the load in such a way that there is no interference at any point within the stroke.**

- 3. Do not scratch or gouge the sliding parts of the cylinder tube or tube rod, etc., by striking or grasping them with other objects.**

Cylinder bores are manufactured to precise tolerances, so that even a slight deformation may cause malfunction. Also, scratches or gouges, etc., in the tube rod may lead to damaged seals and cause air leakage.

- 4. Prevent the seizure of rotating parts.**

Prevent the seizure of rotating parts (pins, etc.) by applying grease.



Series CU Actuator Precautions 2

Be sure to read before handling.

Mounting

⚠ Caution

5. Do not use until you verify that the equipment can operate properly.

After mounting, repairs, or modification, etc., connect the air supply and electric power, and then confirm proper mounting by means of appropriate function and leak tests.

6. Instruction manual

Install the products and operate them only after reading the instruction manual carefully and understanding its contents. Also keep the manual where it can be referred to as necessary.

Piping

⚠ Caution

1. Preparation before piping

Before piping is connected, it should be thoroughly blown out with air (flushing) or washed to remove chips, cutting oil and other debris from inside the pipe.

2. Wrapping of pipe tape

When screwing in pipes and fittings, etc., be certain that chips from the pipe threads and sealing material will not ingress inside the piping.

Also, when pipe tape is used, leave 1.5 to 2 thread ridges exposed at the end of the threads.

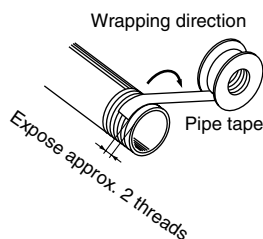

Lubrication

⚠ Caution

1. Lubrication to cylinders

The cylinder has been lubricated at the factory and can be used without any further lubrication.

Air Supply

⚠ Warning

1. Use clean air.

Do not use compressed air which contains chemicals, synthetic oils containing organic solvents, salts or corrosive gases, etc., as this can cause damage or malfunction.

Air Supply

⚠ Caution

1. Install air filters.

Install air filters close to valves at their upstream side. A filtration degree of 5 μm or less should be selected.

2. Install an aftercooler, air dryer, or water separator (Drain Catch).

Air that includes excessive drainage may cause malfunction of valves and other pneumatic equipment. To prevent this, install an air dryer, aftercooler or water separator, etc.

3. Use the product within the specified range of fluid and ambient temperature.

Take measures to prevent freezing when below 5°C, since moisture in circuits can freeze and cause damage to seals and lead to malfunctions.

For details on the quality of compressed air mentioned above, refer to SMC's "Best Pneumatics" catalog vol. 14.

Operating Environment

⚠ Warning

1. Do not use in atmospheres or locations where corrosion hazards exist.

2. In dusty locations or where water or oil, etc., splash on the equipment, take suitable measures to protect the rod.

3. When using auto switches, do not operate in an environment with strong magnetic fields.

Maintenance

⚠ Warning

1. Perform maintenance procedures as shown in the instruction manual.

If it is handled improperly, malfunction or damage of machinery or equipment may occur.

2. Removal of equipment, and supply/exhaust of compressed air

Before any machinery or equipment is removed, first ensure that the appropriate measures are in place to prevent the fall or erratic movement of driven objects and equipment, then cut off the electric power and reduce the pressure in the system to zero. Only then should you proceed with the removal of any machinery and equipment.

When machinery is restarted, proceed with caution after confirming that appropriate measures are in place to prevent cylinders from sudden movement.

⚠ Caution

1. Drain flushing

Remove drainage from air filters regularly.



Series CU Auto Switch Precautions 1

Be sure to read before handling.

Design and Selection

Warning

1. Confirm the specifications.

Read the specifications carefully and use this product appropriately. The product may be damaged or malfunction if it is used outside of its specification range (eg. current load, voltage, temperature or impact, etc.).

2. Pay attention to the length of time that a switch is on at an intermediate stroke position.

When an auto switch is placed at an intermediate position of the stroke and a load connected to the auto switch is driven at the time the slide table passes, the auto switch will operate. However if the speed is too great, the operating time will be shortened and the load may not operate properly. The maximum detectable piston speed is:

$$V \text{ (mm/s)} = \frac{\text{Auto switch operating range (mm)}}{\text{Load operating time (ms)}} \times 1000$$

3. Keep wiring as short as possible.

<Reed switch>

As the length of the wiring to a load gets longer, the rush current at the time the switch is turned ON becomes greater, which may shorten the product's life. (The switch will stay ON all the time.)

- 1) Use a contact protection box when the wire length is 5 m or longer.

<Solid state switch>

- 2) Although the wire length should not affect switch function, use a wire that is 100 m or shorter.

4. Take precautions for the internal voltage drop of the switch.

<Reed switch>

- 1) Switches with an indicator light (Except D-A96, A96V)
 - If auto switches are connected in series as shown below, take note that there will be a large voltage drop because of internal resistance from the light emitting diodes. (Refer to internal voltage drop in the auto switch specifications.) [The voltage drop will be "n" times larger when "n" auto switches are connected.]

Even though an auto switch operates normally, the load may not operate.

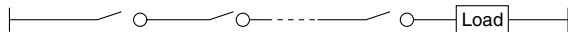

- Similarly, when operating below a specified voltage, it is possible that the load may be ineffective even though the auto switch function is normal. Therefore, the formula below should be satisfied after confirming the minimum operating voltage of the load.

$$\text{Supply voltage} - \text{Internal voltage drop of switch} > \text{Minimum operating voltage of load}$$

- 2) If the internal resistance of a light emitting diode causes a problem, select a switch without an indicator light (Model A90, A90V).

<Solid state switch>

- 3) Generally, the internal voltage drop will be greater with a 2-wire solid state auto switch than with a reed switch. Take the same precautions as in item (1) as mentioned above. Also, note that a 12 VDC relay is not applicable.

5. Pay attention to leakage current.

<Solid state switch>

With a 2-wire solid state auto switch, current (leakage current) flows to the load to operate the internal circuit even when in the OFF state.

$$\text{Current to operate load (Input OFF signal of controller)} > \text{Leakage current}$$

If the condition given in the above formula is not met, internal circuit will not reset correctly (stays ON). Use a 3-wire switch if this specification cannot be satisfied.

Moreover, leakage current flow to the load will be "n" times larger when "n" auto switches are connected in parallel.

6. Do not use a load that generates surge voltage.

<Reed switch>

If driving a load such as a relay which generates a surge voltage, use a contact protection box.

<Solid state switch>

Although a zener diode for surge protection is connected at the output side of a solid state auto switch, damage may still occur if a surge is applied repeatedly. When directly driving a load which generates a surge, such as a relay or solenoid valve, use a switch with a built-in surge absorbing element.

7. Cautions for use in an interlock circuit

When an auto switch is used for an interlock signal requiring high reliability, devise a double interlock system to safeguard against malfunctions. The double interlock system should provide a mechanical protection function or use another switch (sensor) together with the auto switch. Also perform periodic inspection and confirm proper operation.

8. Ensure sufficient clearance for maintenance activities.

When designing an application, be sure to allow sufficient clearance for maintenance and inspections.



Series CU

Auto Switch Precautions 2

Be sure to read before handling.

Mounting and Adjustment

⚠ Warning

1. Do not drop or bump.

Do not drop, bump or apply excessive impacts (300m/s² or greater for reed switches and 1000m/s² or greater for solid state switches) while handling.

Although the body of the switch may not be damaged, the inside of the switch could be damaged and cause a malfunction.

2. Do not carry a cylinder by the auto switch lead wires.

Never carry a cylinder by its lead wires. This may not only cause broken lead wires, but it may cause internal elements of the switch to be damaged by the stress.

3. Mount switches using the proper tightening torque.

When a switch is tightened above the torque specification, the mounting screws, or switch may be damaged. On the other hand, tightening below the torque specification may allow the switch to slip out of position. (Refer to page 7 for switch mounting and tightening torque.)

4. Mount a switch at the center of the operating range.

Adjust the mounting position of an auto switch so that the piston stops at the center of the operating range (the range in which a switch is ON). If mounted at the end of the operating range (around the borderline of ON and OFF), operation will be unstable.

<D-M9□>

When the D-M9 auto switch is used to replace old series auto switch, it may not activate depending on operating condition because of its shorter operating range.

Such as

- Application where the stop position of actuator may vary and exceed the operating range of the auto switch, for example, pushing, pressing, clamping operation, etc.
- Application where the auto switch is used for detecting an intermediate stop position of the actuator. (In this case the detecting time will be reduced.)

In these applications, please set the auto switch to the center of the

⚠ Caution

1. Fix the switch with the appropriate screw installed on the switch body. The switch may be damaged if other screws are used.

Wiring

⚠ Warning

1. Avoid repeatedly bending or stretching lead wires.

Broken lead wires will result from repeatedly applying bending stress or stretching force to the lead wires.

2. Be sure to connect the load before power is applied.

<2-wire type>

If the power is turned ON when an auto switch is not connected to a load, the switch will be instantly damaged because of excess current.

3. Confirm proper insulation of wiring.

Be certain that there is no faulty wiring insulation (such as contact with other circuits, ground fault, improper insulation between terminals, etc.). Damage may occur due to excess current flow into a switch.

Wiring

4. Do not wire in conjunction with power lines or high voltage lines.

Wire separately from power lines or high voltage lines, avoiding parallel wiring or wiring in the same conduit with these lines. Control circuits containing auto switches may malfunction due to noise from these lines.

5. Do not allow short circuit of loads.

<Reed switch>

If the power is turned ON with a load in a short circuited condition, the switch will be instantly damaged because of excess current flow into the switch.

<Solid state switch>

D-M9□ and all models of PNP output type switches do not have built-in short circuit protection circuits. If loads are short circuited, the switches will be instantly damaged, as in the case of reed switches.

Take special care to avoid reverse wiring with the brown [red] power supply line and the black [white] output line on 3-wire type switches.

6. Avoid incorrect wiring.

<Reed switch>

A 24 VDC switch with indicator light has polarity. The brown [red] lead wire is (+), and the blue [black] lead wire is (–).

1) If connections are reversed, the switch will still operate, but the light emitting diode will not light up.

Also note that a current greater than the maximum specified one will damage a light emitting diode and make it inoperable.

Applicable models: D-A93, A93V

<Solid state switch>

1) Even if connections are reversed on a 2-wire type switch, the switch will not be damaged because it is protected by a protection circuit, but it will remain in a normally ON state. But reverse wiring in a short circuit load condition should be avoided to protect the switch from being damaged.

2) Even if (+) and (–) power supply line connections are reversed on a 3-wire type switch, the switch will be protected by a protection circuit. However, if the (+) power supply line is connected to the blue [black] wire and the (–) power supply line is connected to the black [white] wire, the switch will be damaged.

<D-M9□>

D-M9□ does not have built-in short circuit protection circuit. Be aware that if the power supply connection is reversed (e.g. (+) power supply wire and (–) power supply wire connection is reversed), the switch will be damaged.

* Lead wire color changes

Lead wire colors of SMC switches have been changed in order to meet NECA Standard 0402 for production beginning September, 1996 and thereafter. Please refer to the tables provided.

Special care should be taken regarding wire polarity during the time that the old colors still coexist with the new colors.

2-wire

	Old color	Wire color after change
Output (+)	Red	Brown
Output (–)	Black	Blue

3-wire

	Old color	Wire color after change
Power supply	Red	Brown
GND	Black	Blue
Output	White	Black

Solid state with diagnostic output

	Old color	Wire color after change
Power supply	Red	Brown
GND	Black	Blue
Output	White	Black
Diagnostic output	Yellow	Orange

Latch type, solid state with diagnostic output

	Old color	Wire color after change
Power supply	Red	Brown
GND	Black	Blue
Output	White	Black
Latch type Diagnostic output	Yellow	Orange



Series CU

Auto Switch Precautions 3

Be sure to read before handling.

Wiring

⚠ Caution

1. When the cable sheath is stripped, confirm the stripping direction. The insulator may be split or damaged depending on the direction. (D-M9□ only)

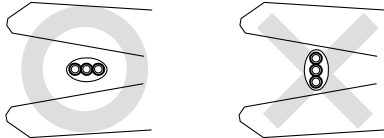

Recommended tool

Manufacturer	Model name	Model no.
VESSEL	Wire stripper	No 3000G
TOKYO IDEAL CO., LTD	Strip master	45-089

* Stripper for a round cable (ø2.0) can be used for a 2-wire type cable.

Operating Environment

⚠ Warning

1. **Never use in an atmosphere of explosive gases.**
The construction of the auto switch is not intended to prevent explosion. Never use in an atmosphere with an explosive gas since this may cause a serious explosion.
2. **Do not use in an area where a magnetic field is generated.**
The auto switch will malfunction or the magnets inside of an actuator will become demagnetized. (There may be the case where the magnetic field resistant auto switch is usable. Contact us for further details.)
3. **Do not use in an environment where the auto switch will be continually exposed to water.**
The switch satisfies the IEC standard IP67 construction (JIS C 0920: watertight construction). Nevertheless, it should not be used in applications where it is continually exposed to water splash or spray. This may cause deterioration of the insulation or swelling of the potting resin inside switch causing a malfunction.
4. **Do not use in an environment with oil or chemicals.**
Consult with SMC if the auto switch will be used in an environment laden with coolant, cleaning solvent, various oils or chemicals. If the auto switch is used under these conditions for even a short time, it may be adversely effected by a deterioration of the insulation, a malfunction due to swelling of the potting resin, or hardening of the lead wires.
5. **Do not use in an environment with temperature cycles.**
Consult with SMC if the switch is used where there are temperature cycles other than normal temperature changes, as they may adversely affected the switch internally.

Operating Environment

6. **Do not use in an environment where there is excessive impact shock.**

<Reed switch>

When excessive impact (300 m/s² or more) is applied to a reed switch during operation, the contact point may malfunction and generate a signal momentarily (1 ms or less) or cut off. Consult with SMC regarding the need to use a solid state switch in a specific environment.

7. **Do not use in an area where surges are generated.**

<Solid state switch>

When there are units (such as solenoid type lifters, high frequency induction furnaces, motors, etc.) that generate a large amount of surge in the area around an actuator with a solid state auto switch, their proximity or pressure may cause deterioration or damage to the internal circuit of the switch. Avoid sources of surge generation and disorganized lines.

8. **Avoid accumulation of iron waste or close contact with magnetic substances.**

When a large amount of iron waste such as machining chips or spatter is accumulated, or a magnetic substance (something attracted by a magnet) is brought into close proximity with an auto switch cylinder, it may cause the auto switch to malfunction due to a loss of the magnetic force inside the cylinder.

Maintenance

⚠ Warning

1. **Perform the following maintenance periodically in order to prevent possible danger due to unexpected auto switch malfunction.**
 - 1) Securely tighten switch mounting screws.
If screws become loose or the mounting position is dislocated, retighten them after readjusting the mounting position.
 - 2) Confirm that there is no damage to the lead wires.
To prevent faulty insulation, replace switches or repair lead wires, etc., if damage is discovered.
 - 3) Confirm that the green light on the 2-color display type switch lights up.
Confirm that the green LED is ON when stopped at the set position. If the red LED is ON, when stopped at the set position, the mounting position is not appropriate. Readjust the mounting position until the green LED lights up.

Other

⚠ Warning

1. **Consult with SMC concerning water resistance, elasticity of lead wires, usage at welding sites, etc.**