

The RF Line  
**CATV Amplifier Module**

**MHW1223LA**

**Features**

- Specified for 6- and 10-Channel Loading
- Excellent Distortion Performance
- Low Power Consumption
- Capable of Handling Multiple Channels in the Return Path with Good Distortion Performance
- Silicon Bipolar Transistor Technology
- Unconditionally Stable Under All Load Conditions

**5-200 MHz, 22.7 dB  
 10-CHANNEL  
 CATV LOW CURRENT AMPLIFIER**

**Applications**

- CATV Systems Operating in the 5 to 200 MHz Frequency Range
- Specified for Use as a Return Path Amplifier for Low-, Mid- and High-Split 2-Way Cable TV Systems

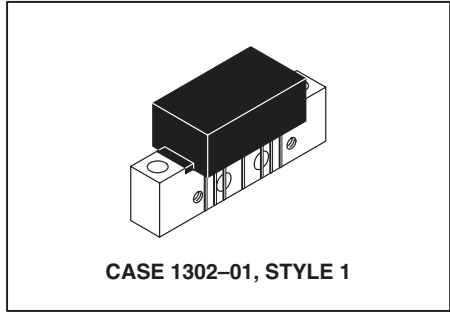

**Description**

- 24 Vdc Supply, 5 to 200 MHz, CATV Reverse Amplifier

**MAXIMUM RATINGS**

Parameter	Symbol	Value	Unit
DC Supply Voltage	$V_{CC}$	+28	Vdc
RF Input Voltage (Single Tone)	$V_{in}$	+60	dBmV
Operating Case Temperature Range	$T_C$	- 20 to +100	°C
Storage Temperature Range	$T_{stg}$	- 40 to +100	°C

**ELECTRICAL CHARACTERISTICS** ( $V_{CC} = 24$  Vdc,  $T_C = 30^\circ\text{C}$ , 75  $\Omega$  system, unless otherwise noted)

Characteristic	Symbol	Min	Typ	Max	Unit
Bandwidth All	BW	5	—	200	MHz
Power Gain (f = 5 MHz)	$G_p$	22.1	22.7	23.5	dB
Slope (5-200 MHz)	S	- 0.2	—	0.7	dB
Gain Flatness (Peak To Valley) (5-200 MHz)	$G_F$	—	—	0.4	dB
Return Loss — Input/Output (@ f = 5-150 MHz) (@ f = 150-200 MHz)	IRL/ORL	20 18	— —	— —	dB
Composite Second Order ( $V_{out} = +50$ dBmV per Ch., Worst Case)					dBc
6-Channel FLAT	$CSO_6$	—	- 73	- 68	
10-Channel FLAT	$CSO_{10}$	—	- 72	- 65	

# Freescale Semiconductor, Inc.

## ELECTRICAL CHARACTERISTICS – continued ( $V_{CC} = 24$ Vdc, $T_C = 30^\circ\text{C}$ , $75\ \Omega$ system, unless otherwise noted)

Characteristic	Symbol	Min	Typ	Max	Unit
Cross Modulation Distortion ( $V_{out} = +50$ dBmV per Ch., Worst Case)	6-Channel FLAT	—	-69	-65	dBc
	10-Channel FLAT	—	-63	-60	
Composite Triple Beat ( $V_{out} = +50$ dBmV per Ch., Worst Case)	6-Channel FLAT	—	-78	-75	dBc
	10-Channel FLAT	—	-69	-66	
Noise Figure ( $f = 5$ – $200$ MHz)	NF	—	6.3	7	dB
DC Current	$I_{DC}$	85	95	110	mA

**NOTES**

# Freescale Semiconductor, Inc.

## PACKAGE DIMENSIONS

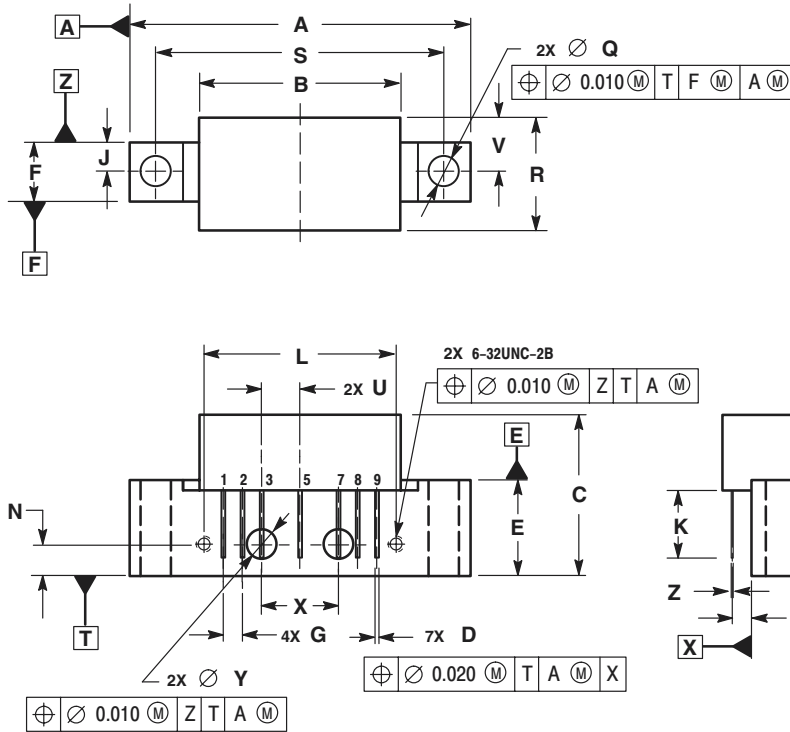

DIM	INCHES		MILLIMETERS	
	MIN	MAX	MIN	MAX
A	---	1.775	---	45.085
B	---	1.085	---	27.559
C	---	0.840	---	21.336
D	0.015	0.021	0.381	0.533
E	0.465	0.510	11.811	12.954
F	0.300	0.325	7.62	8.255
G	0.100 BSC		2.540 BSC	
J	0.156 BSC		3.962 BSC	
K	0.315	0.355	8.001	9.017
L	1.000 BSC		25.400 BSC	
N	0.165 BSC		4.191 BSC	
P	0.100 BSC		2.540 BSC	
Q	0.148	0.168	3.759	4.267
R	---	0.600	---	15.24
S	1.500 BSC		38.100 BSC	
U	0.200 BSC		5.080 BSC	
V	---	0.250	---	6.350
W	0.435	---	11.049	---
X	0.400 BSC		10.160 BSC	
Y	0.152	0.163	3.861	4.140
Z	0.009	0.011	0.229	0.279

STYLE 1:  
 PIN 1. RF INPUT  
 2. GROUND  
 3. GROUND  
 4. DELETED  
 5. VDC  
 6. DELETED  
 7. GROUND  
 8. GROUND  
 9. RF OUTPUT

CASE 1302-01  
 ISSUE B

Motorola reserves the right to make changes without further notice to any products herein. Motorola makes no warranty, representation, or guarantee regarding the suitability of its products for any particular purpose, nor does Motorola assume any liability arising out of the application or use of any product or circuit, and specifically disclaims any and all liability, including without limitation consequential or incidental damages. "Typical" parameters can and do vary in different applications and actual performance may vary over time. All operating parameters, including "Typicals", must be validated for each customer application by customer's technical experts. Motorola does not convey any license under its patent rights nor the rights of others. Motorola products are not designed, intended, or authorized for use as components in systems intended for surgical implant into the body, or other applications intended to support or sustain life, or for any other application in which the failure of the Motorola product could create a situation where personal injury or death may occur. Should Buyer purchase or use Motorola products for any such unintended or unauthorized application, Buyer shall indemnify and hold Motorola and its officers, employees, subsidiaries, affiliates, and distributors harmless against all claims, costs, damages, and expenses, and reasonable attorney fees arising out of, directly or indirectly, any claim of personal injury or death associated with such unintended or unauthorized use, even if such claim alleges that Motorola was negligent regarding the design or manufacture of the part. Motorola and the Stylized M Logo are registered in the US Patent & Trademark Office. All other product or service names are the property of their respective owners. Motorola, Inc. is an Equal Opportunity/Affirmative Action Employer.

© Motorola, Inc. 2002.

### How to reach us:

**USA/EUROPE/Locations Not Listed:** Motorola Literature Distribution; P.O. Box 5405, Denver, Colorado 80217. 1-303-675-2140 or 1-800-441-2447

**JAPAN:** Motorola Japan Ltd.; SPS, Technical Information Center, 3-20-1, Minami-Azabu. Minato-ku, Tokyo 106-8573 Japan. 81-3-3440-3569

**ASIA/PACIFIC:** Motorola Semiconductors H.K. Ltd.; Silicon Harbour Centre, 2 Dai King Street, Tai Po Industrial Estate, Tai Po, N.T. Hong Kong. 852-26668334

**Technical Information Center: 1-800-521-6274**

**HOME PAGE:** <http://www.motorola.com/semiconductors/>



**MOTOROLA**

For More Information On This Product,  
 Go to: [www.freescale.com](http://www.freescale.com)

MHW1223LA/D