

Carbon Film, Cylindrical, Fusible Resistors

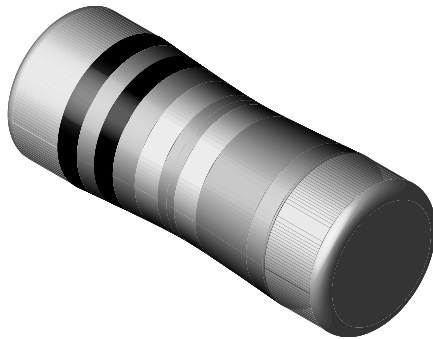

FEATURES

- Fusible resistor for constant voltage designed for overload protection
- Specially spiralled to provide the fusible function
- Flame retardant coating
- Used in battery chargers, TV-sets, cordless phones, PC/CPU-cooler

STANDARD ELECTRICAL SPECIFICATIONS

MODEL	POWER RATING $P_{70^{\circ}\text{C}}^{(1)}$ W	TEMPERATURE COEFFICIENT ppm/K	TOLERANCE %	RESISTANCE RANGE Ω	E-SERIES
LCM0207SI	0.25	+ 300/- 250	5	R22 – 1K0	24

¹⁾ Power rating depends on the maximum temperature at the solder point, the component placement density and the substrate material.

- Coating: beige
- Marking and packaging :see appropriate catalog or web page additional 5th band yellow

TECHNICAL SPECIFICATIONS

PARAMETER	UNIT	LCM0207SI	
Rated Dissipation at 70°C	W	0.25	
Minimum Overload to Fuse	W	> 1R0	4
		< 1R0	5
Time to Fuse (max)	s	15	
Derating		Linear to + 125°C	
Thermal Resistance	K/W	≤ 220	
Voltage Coefficient	V ⁻¹	≥ 10 ⁻⁷	
Category Temperature Range	°C	- 55 / + 125	
Failure Rate	10 ⁻⁹ /h	< 30	
Weight / 1000pcs	g	71	

ORDERING INFORMATION

LCM0207SI	+ 300/- 250	5R6	5%	BP
MODEL	TC ppm / K	RESISTANCE VALUE Ω	TOLERANCE ± %	PACKAGING BP-Blistertape 1500 pcs

DIMENSIONS

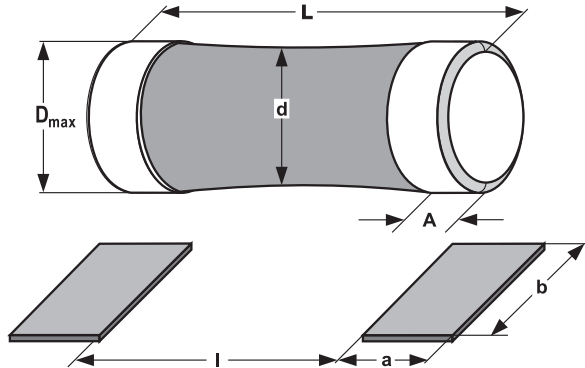

MODEL	DIMENSIONS [in millimeters]				
	D _{max}	d *	L	A _{max}	A _{min}
LCM0207SI	2.2	D - 0.4	5.8 - 0.3	1.2	0.6

* d measured in the middle of the resistor

MODEL	SOLDER PAD DIMENSIONS [in millimeters]					
	REFLOW SOLDERING			WAVE SOLDERING		
	a	b	l	a	b	l
LCM0207SI	1.8	2.5	2.9	2.4	2.5	2.8

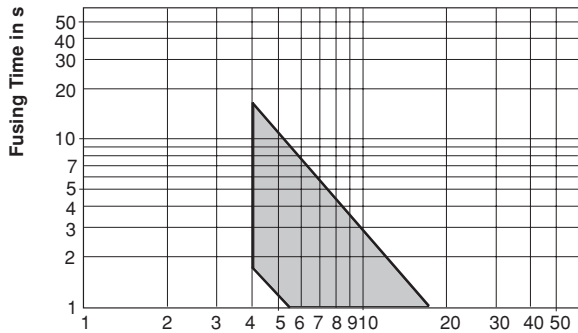

Fusing Performance

Power in W

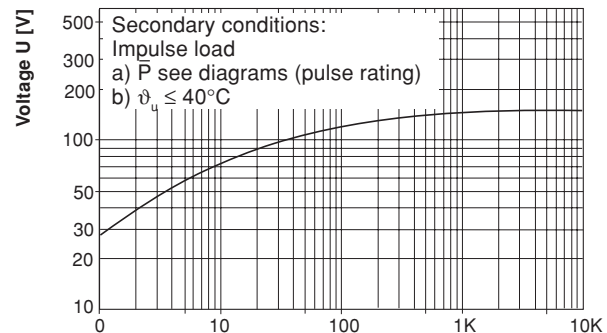

U_{max} in case of failure and max. Pulse voltage Resistance Value in Ω

PERFORMANCE		
TEST	CONDITIONS OF TEST	REQUIREMENTS
Endurance Test at 70°C IEC 60115-1 4.25.1	1000 hours at 70°C 1.5 hours "ON" 0.5 hours "OFF"	≤ ± 2.0 %
Endurance at UCT IEC 60115-1 4.25.3	1000 hours at 125°C without load	≤ ± 2.0 %
Thermal Shock IEC 60115-1 4.19 IEC 60068-2-14	Rapid change between upper and lower category temperature	≤ ± 0.5 %
Damp Heat Steady State IEC 60115-1 4.24 IEC 60068-2-3	56 days at 40°C and 93% relative humidity	≤ ± 2.0 %
Resistance to Soldering Heat IEC 60115-1 4.18 IEC 60068-2-20	10 seconds at 260°C solder bath temperature	≤ ± 0.25 %

PACKAGING: See SMM0207

SOLDERING INFORMATION
<ul style="list-style-type: none"> For reflow soldering only Board has to be thoroughly cleaned after soldering. All flux materials must be completely removed