

- **CMX639 Product Evaluation**
- **Telephone Handset Connectors**
- **On-board Speaker Driver**
- **Variable Gain Input Amplifier**
- **Selectable Sample Clock Rates**
- **Easy Jumper/Switch configuration**
- **User Prototyping PCB Area**

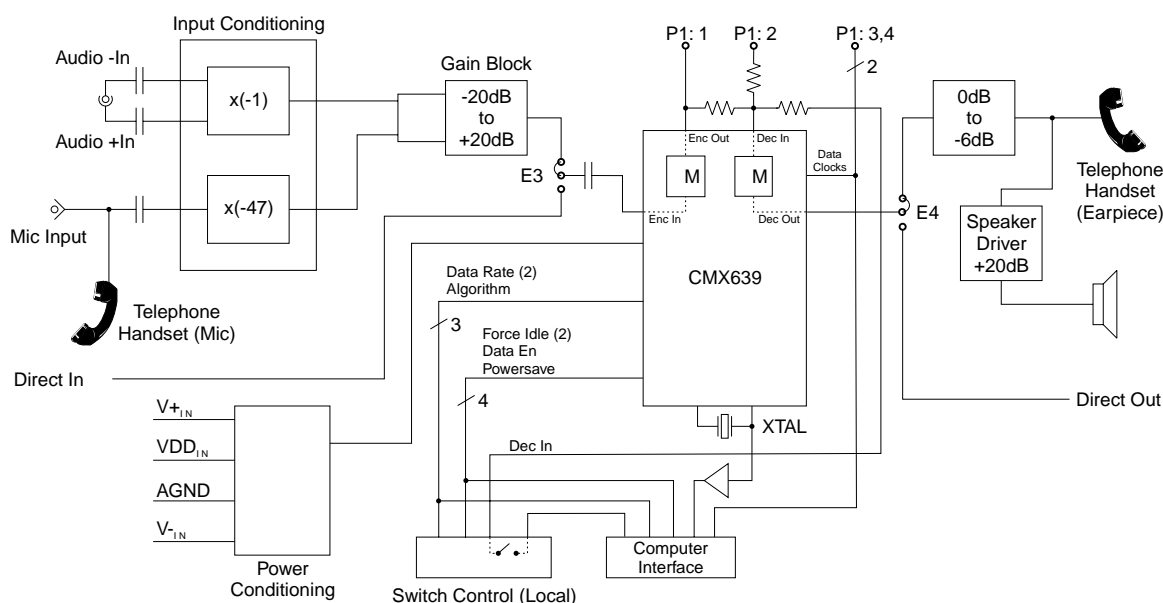

The EV6090 is a single board evaluation platform used for the evaluation of the CMX639 CVSD codec. The board is powered from an external supply that can be used to evaluate CVSD encoder and decoder performance at different supply voltages.

Jumpers are provided to select signal paths, clock source, measure device current, etc.

Convenient I/O allows connection to a telephone handset, microphone, and/or a loudspeaker for simple experiments.

CONTENTS

Section	Page
1 Block Diagrams.....	3
2 Preliminary Information.....	5
2.1 Laboratory Equipment	5
2.2 Handling Precautions	5
2.2.1 Static Protection.....	5
2.2.2 Contents - Unpacking.....	5
3 Operation.....	5
3.1 Set-Up.....	5
3.1.1 Default Jumper Configuration.....	5
3.1.2 Connect external regulated power supply.	6
3.1.3 Set Mode of Operation	6
3.1.4 Quick Test	6
3.1.5 Further experimentation	6
3.2 Adjustments.....	6
3.3 Operation	6
3.3.1 E3 Audio Input routing (to the CVSD encoder).....	6
3.3.2 E4 Audio output routing (from the CVSD decoder)	6
3.3.3 S1 and S2 Switch Settings	7
4 Schematic Diagrams and PCB Layout.....	9
5 Specifications	11

MX-COM, Inc. reserves the right to change specifications at any time and without notice.
--

1 Block Diagrams

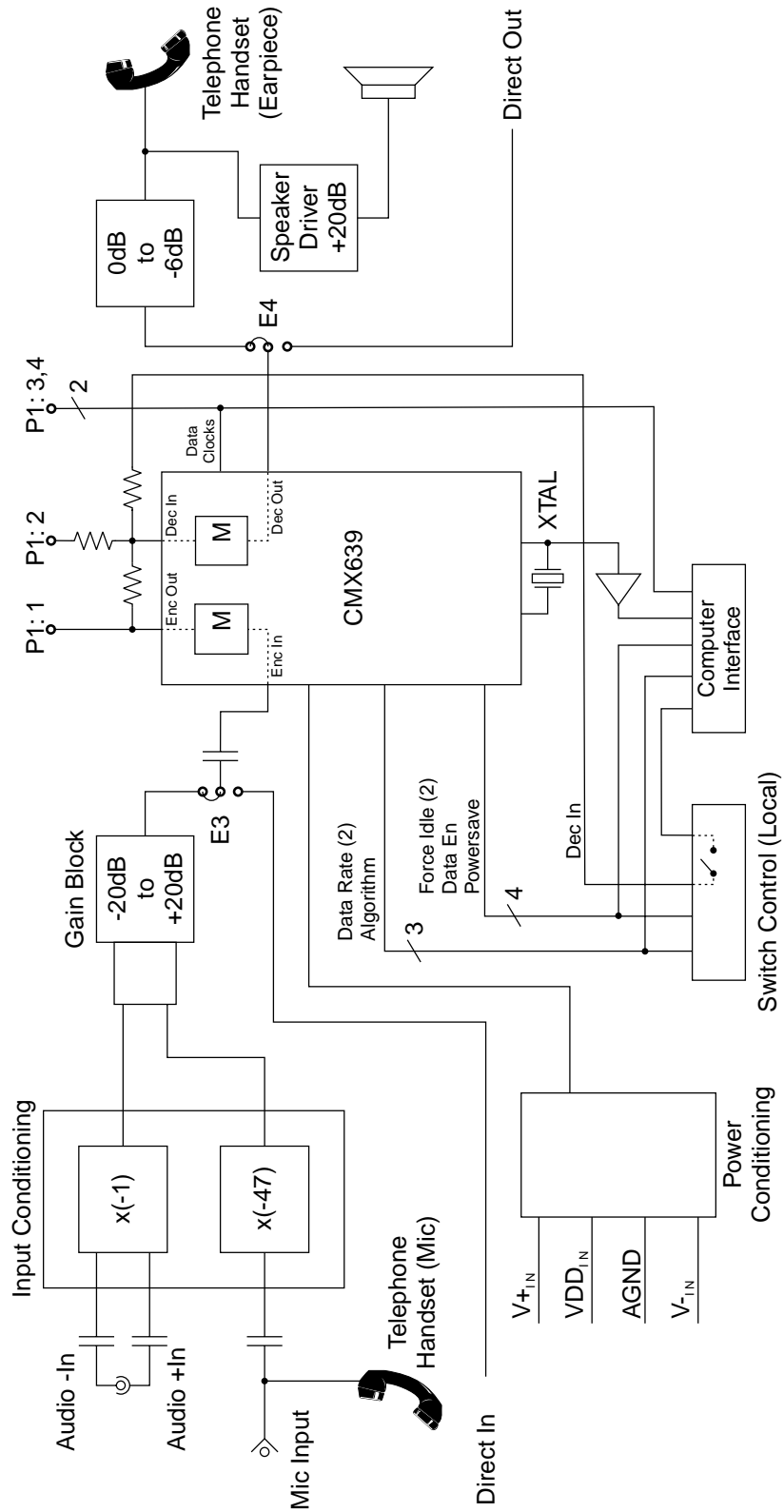

Figure 1: Block Diagram

2 Preliminary Information

2.1 Laboratory Equipment

The following laboratory equipment must be user supplied to use this evaluation kit:

Required

- 2.7-5.0V regulated DC Power Supply

Optional

- 8Ω speaker or headphones. **NOTE:** A stereo jack is supported because it is popular and available. If a mono plug is connected it will mute the output signal by creating a short to ground. A mono loudspeaker may be connected but it must have a stereo plug.
- Microphone
- POTS (*Plain Old Telephone System*) telephone handset may be used to listen to CVSD encoded and decoded speech.

2.2 Handling Precautions

This evaluation kit is designed for use in office and laboratory environments. The following practices will help ensure its proper operation.

2.2.1 Static Protection

This product uses low power CMOS circuits which can be damaged by electrostatic discharge. Partially damaged circuits can function erroneously, leading to misleading results. Observe ESD precautions at all times when handling this product.

2.2.2 Contents - Unpacking

Please ensure that you have received all of the items on the separate information sheet (EK6090) and notify MX-COM within 7 working days if the delivery is incomplete.

3 Operation

3.1 Set-Up

THE EV6090 IS CONFIGURED WITH A CMX639 DIP DEVICE FOR OPERATION AT 2.7 to 5.0VDC.

A 4-conductor modular jack (J2), sometimes referred to as an 'RJ22 jack,' has been provided to allow for quick speak/listen evaluation using a standard POTS handset. The following quick start will allow connection of a handset and power supply to quickly evaluate encoded and decoded CVSD audio. The user can select different sample clock rates and modes of operation to familiarize themselves with the operation of the CVSD device.

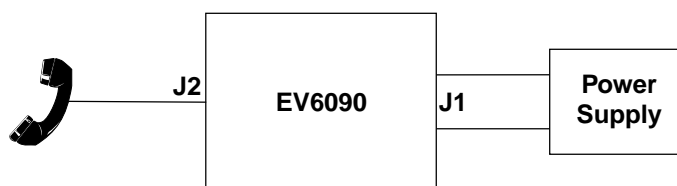

Figure 4: POTS Set-Up

3.1.1 Default Jumper Configuration

- For single supply operation ensure shorting jumpers are installed at locations: E12, E6, E8, P4, and E5.
- To use the on-board crystal ensure jumpers E1 and E2 are installed.
- Ensure jumper E3 is set to position 1 and position 2, and jumper E4 is shorting position 2 to position 3 for audio routing to the handset.
- Install E13 to route handset to summing amplifier.

3.1.2 Connect external regulated power supply.

- Adjust the supply for 5.0V
- Connect the positive lead from the power supply to “VDDIN” (P3:2) and the negative lead to “GND” (P3:3).

3.1.3 Set Mode of Operation

To begin EV6090 operation, set switches S1-C1 (“CLKMODE1”) to OFF and S1-C2 (“CLKMODE2”) to ON to enable 32kbps sampling mode. Next, ensure that switch S1-C3 (“ALGORITHM”) is set to OFF to enable the 3-bit algorithm. Alternatively, change S1 switch position C1 and C2 as shown in Table 1 for other sample rates.

3.1.4 Quick Test

Connect handset and apply power. Adjust R6 clockwise to increase microphone audio level. Adjust R31 counterclockwise to increase audio level in the ear piece.

3.1.5 Further experimentation

Other modes of operation are available for test. Forced idle channel mode of either the encoder or decoder can be realized by changing dip switch settings. The use of Table 1, coupled with a review of the CMX639 data bulletin, will allow the user to exercise all operating modes.

3.2 Adjustments

R6 - adjust audio input level to the CODEC.

R31 - adjust level for both the telephone hand set and speaker volume.

3.3 Operation

Jumpers E3 and E4 allow for different audio input and output routing.

For testing with audio signals applied at the “AUDIO IN” jack, jumper E13 should be removed to avoid having undesired amplified signals injected into the encoder input.

For testing with audio signals supplied by either the microphone input or the telephone handset, jumper E13 should be installed. Due to the high gain nature of this signal path, however, R6 doesn't need to be adjusted >0dB.

3.3.1 E3 Audio Input routing (to the CVSD encoder)

Jumper position 1 to 2 enables the following:

- RCA Audio input - RC1
- Mic Input – J3
- Telephone Hand set input – J2

Jumper position 2 to 3 enables the following

- Screw Terminal strip P2:1 input

3.3.2 E4 Audio output routing (from the CVSD decoder)

Jumper position 1 to 2 enables output audio to the following:

- RCA Audio output – RC2
- Screw Terminal strip P2:3 output

Jumper position 2 to 3 enables output audio to the following:

- Telephone Hand set output – J2
- Speaker output J4

3.3.3 S1 and S2 Switch Settings

Switch	Name	Description	Circuit Condition When Switch Is:	
			ON	OFF
S1-C1	CLKMODE1	Used in conjunction with CLKMODE2 to set sampling rate and source (internal or external).	See table on EV6090 for switch combinations.	
S1-C2	CLKMODE2	Used in conjunction with CLKMODE1 to set sampling rate and source (internal or external).	See table on EV6090 for switch combinations.	
S1-C3	ALGORITHM	Determines whether 3-bit or 4-bit companding algorithm will be used. In general, 3-bit companding yields better results at rates of 32kbps and below, while 4-bit companding should be used at 48kbps and above.	4-bit algorithm	3-bit algorithm
S1-C4	DATAEN	This switch is used in combination with the /POWERSAVE switch to determine the state of the CMX639 encoder output.	Encoder output is at high impedance regardless of state of /POWERSAVE switch.	Encoder output is enabled if /POWERSAVE switch is OFF, and is set to V_{SS} if it is ON.
S2-C1	/ENCODERFORCEIDLE	This switch causes a "perfect idle" pattern of 0101... to be present at encoder output.	Encoder produces idle pattern at output.	Encoder operates normally.
S2-C2	DECIN	This switch selects the source of the decoder input signal.	Decoder input taken from PCMCIA interface.	Decoder input taken from either DECIN screw terminal or encoder output.
S2-C3	/DECODERFORCEIDLE	This switch causes a 0101... pattern to be internally applied to the CMX639 decoder, resulting in the decoder output pin going to $V_{DD}/2$.	Decoder output is $V_{DD}/2$.	Decoder operates normally.
S2-C4	/POWERSAVE	This switch is used in combination with the DATAEN switch to determine the state of the CMX639 encoder output.	CMX639 is in powersave mode.	CMX639 operates normally.

Table 1: S1 and S2 Switch Settings

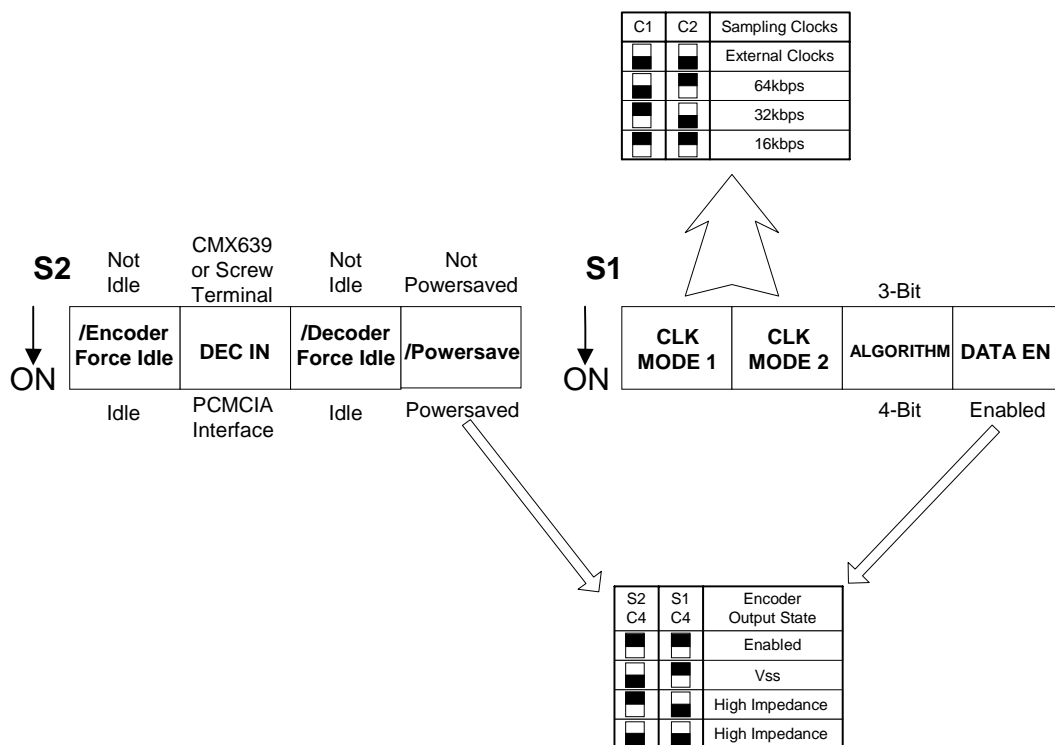

Figure 5: EV6090 Switch Settings

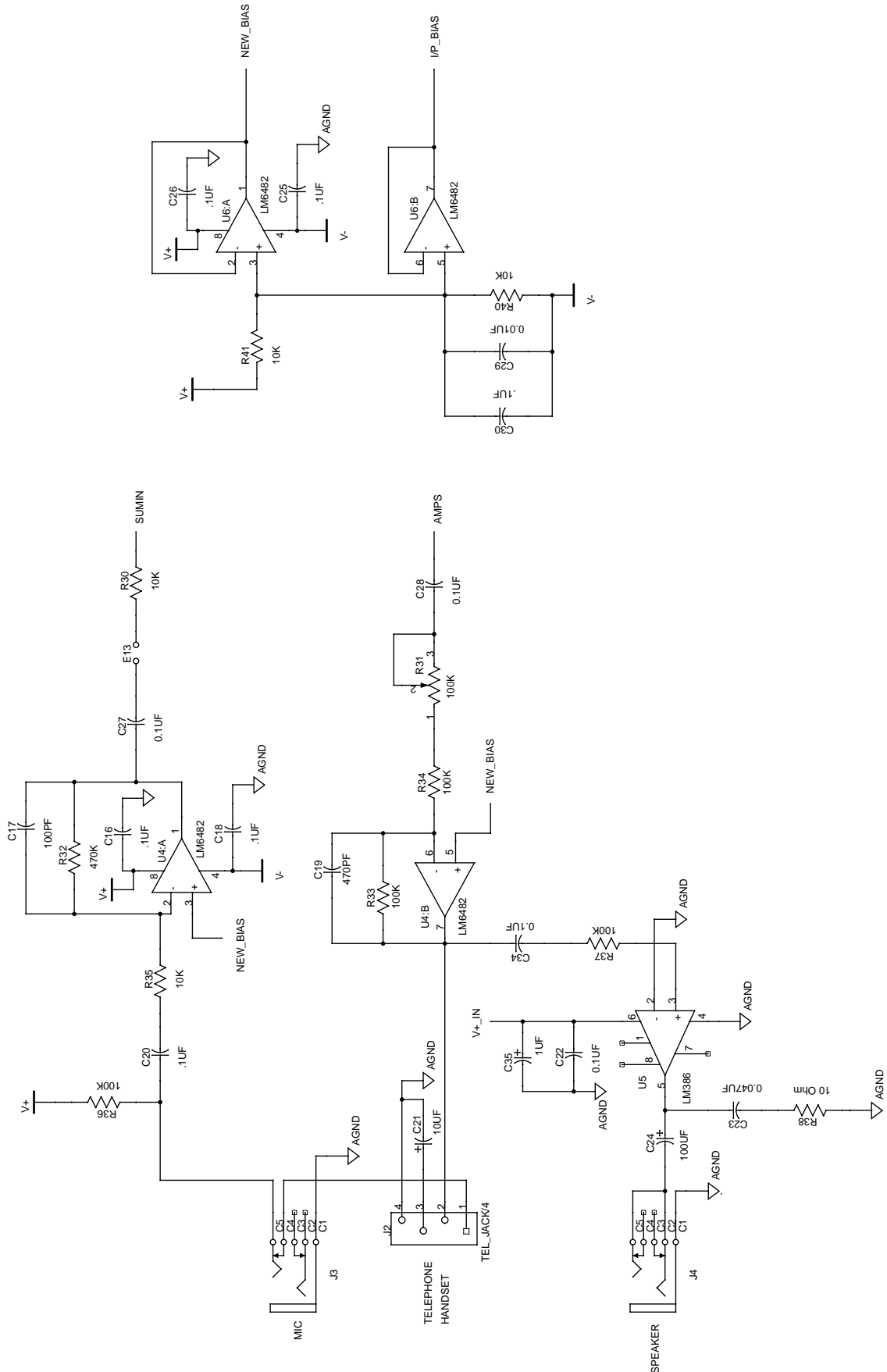

Figure 7: Audio Amp Section

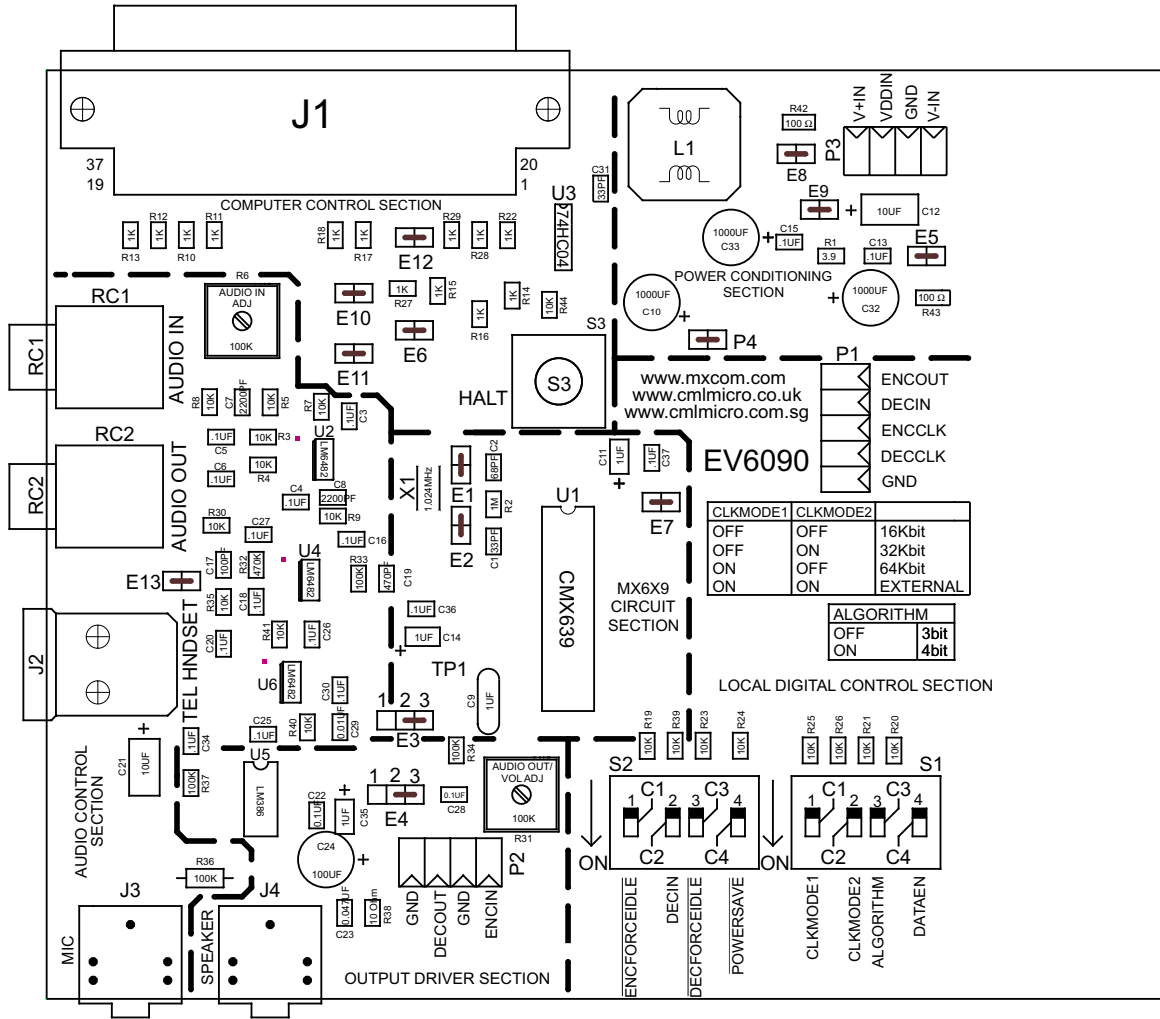

Figure 8: Evaluation Board Layout

5 Specifications

Characteristic	Signal Designator	Connector Designator	Min	Typ	Max	Units
Storage temperature			-20		70	°C
Operating temperature			10		35	°C
Analog ground	AGND	J2:4, J3:C1, J4:C1, P2:2, P2:4, P3:3	0	0	0	V
Analog positive supply voltage	V+ IN	P3:1	2.7		5.5	V
Analog negative supply voltage	V- IN	P3:4	-5.5		0	V
DUT & Digital supply voltage	VDD IN	P3:2	3.0		5.5	V
Microphone input jack type	MIC	J3:C1, C5		mono or stereo		
Speaker output jack type	SPEAKER	J4:C1, C3, C5		stereo		